

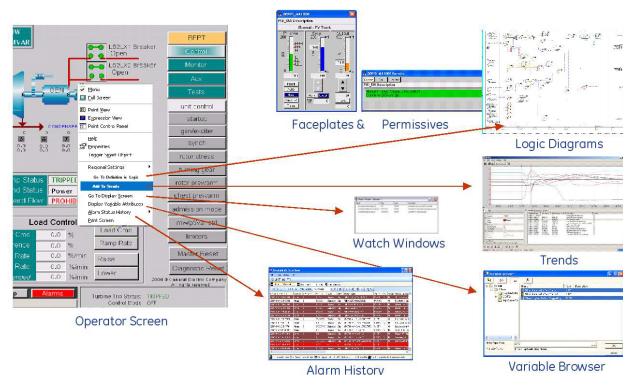

ControlST* Software Suite

fact sheet
GEA-S1252C



Convenient Right-click Screen Navigation

GE's advanced ControlST software suite provides the foundation for the Mark* VIe Control System in a wide range of applications, including thermal, nuclear, oil and gas, wind, solar, and hydro. These diverse sets of applications include the control, monitoring, and protection of everything from turbine-generators to entire plants.

Combining the best attributes of rotating machinery control with balance-of-plant control, the ControlST software suite offers flexible tools with a common time-coherent dataset to simplify operation and reduce life-cycle cost. In addition, it supports the latest model-based control technology derived from GE's thermodynamic design models to deliver the performance, operability, and reliability needed in today's energy market.

Contents

The ControlST software suite includes several high-performance tools, including the WorkstationST* HMI and Historian management software, the ToolboxST* configuration and diagnostic software, CIMPLICITY* graphics tools, and other packages for efficient plant-wide communications, monitoring, and asset management.

WorkstationST Application

The WorkstationST software provides the basis for the operator experience with integration of the graphics tools. It allows for management of alarms, events, logging, real-time and historical data, networks, software security, web interface, and other ToolboxST software functions. An operator can right-click to display a menu for navigation to related logic diagrams, trends, Watch Windows, variables, and alarm history. The alarm management tool set is based on ANSI/ISA-18.2, Management of Alarm Systems for the Process Industries to assist in improving the safety, quality, and productivity of the facility.

An embedded short-term data historian and configuration of Proficy* and OSIsoft® PI long-term data historians is supported. Historian features include:

- Configure storage of data from OPC® DA server
- Configure variables with a defined historian deadband
- Override pre-configured variables
- Add variables that were not pre-configured
- Configure historian reports
- Configure archive backup management

Protocols for integrating plant instrumentation include:

- OPC AE, OPC DA, and OPC UA servers for viewing alarms and events
- Modbus® serial and Ethernet
- Ethernet Global Data (EGD)
- GEDS Service Messaging (GSM)
- Network Time Protocol (NTP) for synchronization

For communications with electrical substation automation systems, additional OPC DA servers for IEC™ 61850, IEC 60870-5-101, and Distributed Network Protocol (DNP 3.0) can be supplied.

ToolboxST Application

The ToolboxST application allows you to configure hardware and control software from I/O modules and controllers to operator stations and networks. This simplifies plant configuration and enhances troubleshooting of system abnormalities. Configuration management tools are also included for revision control and historical record-tracking.

Recommended Hardware and Operating System

Item	Description
OS	64-bit Windows 7 Ultimate, SP1 64-bit Windows Server 2008R2, single-user, SP1
CPU	Dual core or better
Memory	4 GB RAM (or more)
HD	40 GB (or more)
Monitor	1280 x 1024 x Truecolor (24 million or better)
Drive	DVD
Network	Ethernet 10/100 MB
USB	Two available USB ports
Supported	
	32-bit Windows® XP Professional, SP3 32-bit Windows Server 2003, single-user 32-bit Windows 7 Ultimate, SP1

Control Software

The ToolboxST application displays control software in ladder, SAMA-style, and IEC-61131-3-compliant Sequential Function Chart (SFC) formats. The blocks are maintained in application-specific block libraries such as the Mark VIeS Safety Controller Block Library, and annotated with functional descriptions for online user help.

A typical logic diagram displays the status of internal block calculations and the external data to and from the blocks. To simplify reading, the connections between the blocks are color-coded and marked with solid and dashed lines to designate data quality, Boolean logic, and forced data points. Search tools are provided for locating text, overrides, differences, and variables along with hyperlinked cross-references.

Control software can be edited with user-friendly features, such as drag-and-drop of variables between blocks, and then downloaded to the controllers. Online downloads are supported for simplex, dual, and triple redundant controller configurations.

Trends

For convenience, variables can be dragged from logic diagrams to trends, and analyzed at the controller's frame rate for the best dynamic response. Trends support historical data and live (real-time) data with historical backfill.

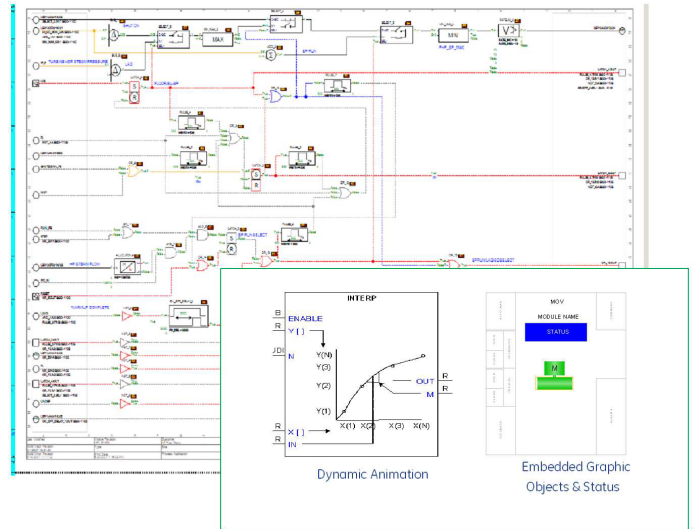

Logic Diagram with Block Animation and Hyperlinks

Additional trending features:

- Stacked traces
- Alarm/event designation on the X-axis
- Dual cursors with: delta, min, max, average, RMS, standard deviation indication
- Automatic upload when the capture blocks are triggered
- Browser for variables selection
- Export and import trend data from any OPC HDA data source

Plant Integration

To complete the integration of plant assets, the ControlST software suite provides:

Virtual Controller simulates control responses in a software environment for dynamic simulations used in control system validations and operator training simulators.

Sequence of Events Monitoring is embedded in all turbine, generator, and balance-of-plant controls to enable a quick root cause analysis of trips from the power-island, electrical equipment, and grid dynamics.

Device Management for digital networks uses Device Manager Gateway with FDT/DTM technology and either the GE Device Manager Essentials or Metso Fieldcare software to provide communication to the GE control system through HART®, PROFIBUS, or FOUNDATION Fieldbus™ protocols.

Benefits

- Improved operator effectiveness
- Reduced maintenance with a common time-coherent dataset
- Less life-cycle cost with an integrated software suite

For further assistance or technical information, contact the nearest GE Sales or Service Office, or an authorized GE Sales Representative.

© 2010 - 2014 General Electric Company, USA. All rights reserved. * Indicates a trademark of General Electric Company and/or its subsidiaries. All other trademarks are the property of their respective owners.

GEA-S1252C Issued: Jul 2010 Revised: Aug 2014