



GE VERNOVA

MARK* VIE CONTROL

PRODUCT DESCRIPTION

CONTENTS

- 1 Introduction.....3**
- 2 System Overview.....4**
 - 2.1 Redundancy4
 - 2.2 I/O Interface5
 - 2.3 Terminal Blocks.....6
 - 2.4 Temperature Ratings.....7
 - 2.5 I/O Modules.....7
 - 2.6 IONet13
 - 2.7 Controller.....15
 - 2.8 Cyber Security.....16
- 3 ControlST Software Suite.....18**
 - 3.1 Human-machine Interface (HMI).....18
 - 3.2 WorkstationST HMI and Historian Software19
 - 3.3 ToolboxST Configuration and Diagnostic Application24
- 4 Technical Regulations and Standards.....29**

INTRODUCTION

The Mark* V1e control system is a flexible platform used in multiple applications. It features high-speed, networked input/output (I/O) for simplex, dual, and triple redundant systems. Industry-standard Ethernet communications are used for I/O, controllers, and supervisory interface to operator and maintenance stations, as well as third-party systems. The ControlST* software suite, which contains the ToolboxST* toolset, is used with Mark V1e controls and related systems for programming, configuration, trending, and analyzing diagnostics. It provides quality, time-coherent data in the controllers and at the plant level for effectively managing control system equipment. The Mark V1eS Safety control is a stand-alone safety control system for safety-critical applications that conform to IEC®-61508. It also uses the ControlST software suite to simplify maintenance, but retains a unique set of certified hardware and software blocks. The ToolboxST application provides a means to lock or unlock the Mark V1eS for configuration and safety instrumented function (SIF) programming.

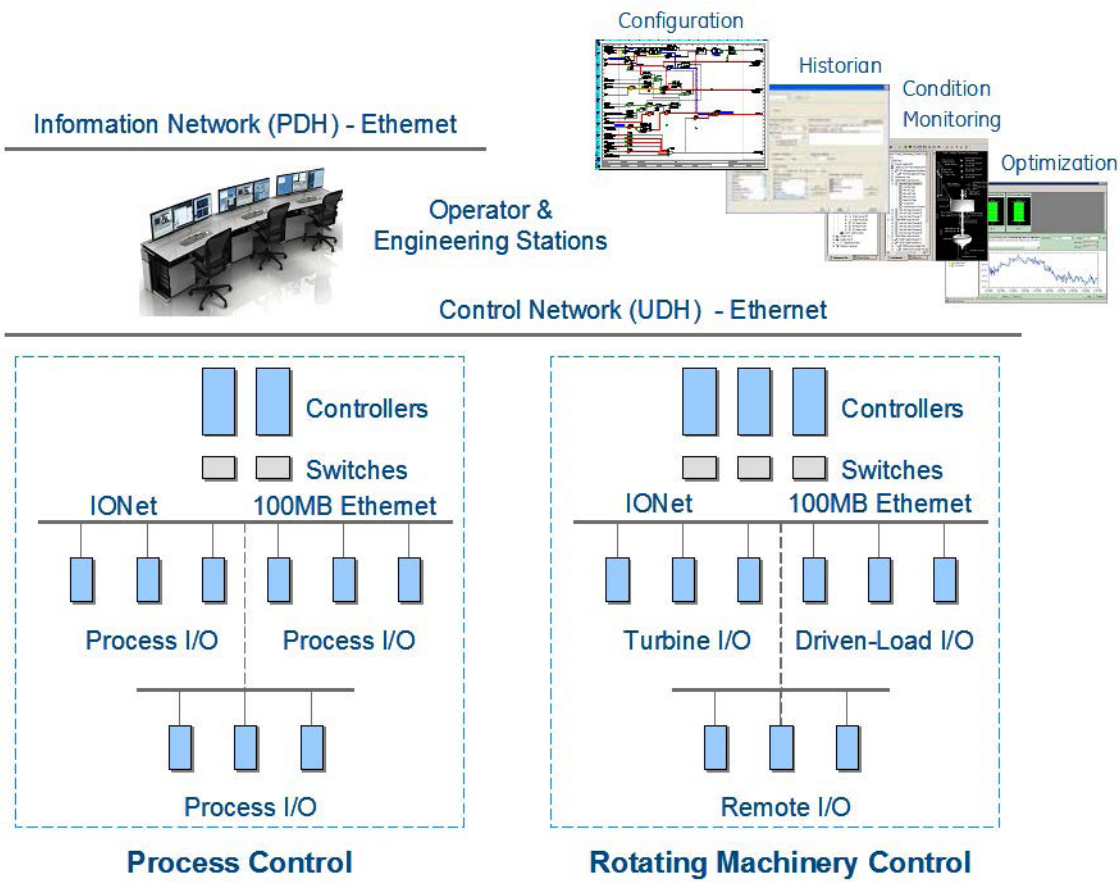

SYSTEM OVERVIEW

A single-board controller is the heart of the system. The controller includes the main processor and redundant Ethernet drivers to communicate with networked I/O, and additional Ethernet drivers for the control network. A real-time, multi-tasking operating system is used for the main processor and I/O modules. Control software is provided in a configurable control block language and stored in non-volatile memory. It is similar to IEEE® 854 32-bit floating-point format, and Sequential Function Charts (SFC) are also available for complex sequencing.

The I/O network (IONet) is a dedicated, full-duplex, point-to-point protocol. It provides a deterministic, high-speed 100 MB communications network that is suitable for local or distributed I/O devices, and provides communication between the main controller(s) and networked I/O modules. Online controllers continuously read input data directly from the IONet, which is available in single, dual, and triple redundant configurations. Both copper and fiber interfaces are supported.

The Mark VIe I/O modules consist of three basic parts: the terminal board, the terminal block, and an I/O pack. Barrier or box-type terminal blocks are mounted on a terminal board, which mounts on a DIN rail or base in the control cabinet. The I/O pack contains two Ethernet ports, a power supply, a local processor, and a data acquisition board. I/O capability grows as I/O packs are added to the control system, enabling use in a simplex, dual, or triple redundant configuration. Some process sub-systems require even more throughput; therefore, the local processors in each I/O pack run algorithms at higher rates as required for the application.

100 MB Ethernet is used for communication to local and distributed I/O modules.

REDUNDANCY

Every application has different requirements for redundancy depending on the criticality of the process. The Mark VIe control system provides a wide range of redundancy options for local and remote distribution.

Control Components	Redundancy Level		
Power sources	Single	Dual	Triple
Power supplies	Single	Dual	Triple
I/O packs per I/O module	Single	N/A	Triple
Ethernet ports per I/O pack	Single	Dual	N/A
IONet	Single	Dual	Triple
Control Network	Single	Dual	N/A

Dual redundant systems transmit inputs from single or redundant input packs on dual IONets to dual Mark VIe controllers. Controllers then run application software and transmit outputs to output packs. Three output I/O packs may be provided to vote output signals for mission-critical field devices. Dual redundant systems may be configured for single, dual, and triple redundant sensors.

Triple redundant systems protect against soft or partial device failures. A failed component is outvoted with a 2-out-of-3 logical selection (vote) or a median value selection. Control software in all three Mark VIe controllers runs on the voted value of the signal while diagnostics identify the failed device. These sophisticated diagnostics reduce the mean-time-to-repair (MTTR) while the online repair capability increases the mean-time-between-forced-outages (MTBFO). Field sensors for these systems may be single, dual, or triple.

I/O INTERFACE

One or multiple I/O packs are mounted on each module to digitize the sensor signal, run algorithms, and communicate with a separate controller containing the main processor. I/O packs have a local processor board that runs a real-time operating system and a data acquisition board that is unique to the specific I/O application. Local processors run algorithms at faster speeds than the overall control system, such as the regulation of servo valves performed within a servo module.

Each I/O processor has a local temperature sensor accurate to $\pm 2^{\circ}\text{C}$ ($\pm 3.6^{\circ}\text{F}$). Detection of an excessive temperature generates a diagnostic alarm and the logic is available in the database (signal space) to facilitate control action or unique process alarm messages. The temperature is continuously available in the database. I/O module features include:

- Dual 100 MB Ethernet ports
- 100 MB full-duplex ports
- Online repair per I/O pack
- Automatic reconfiguration
- Accuracy is specified over full operating temperature
- Internal temperature sensor
- LEDs:
 - Power status and attention
 - Ethernet link-connected and communication-active
 - Application-specific
- 28 V dc power
- Internal solid-state circuit breaker and soft start

A power supply provides a regulated 28 V dc power feed to each I/O pack. The negative side of the 28 V dc is grounded through the I/O pack metal enclosure and its mounting base. The positive side has solid-state circuit protection built into the I/O pack with a nominal 2 A trip point. Online repair is possible by removing the 28 V dc connector, replacing the I/O pack, and re-inserting the power connector. I/O packs are automatically reconfigured if the Auto-Reconfiguration feature is enabled.

Every I/O pack communicates directly over the IONet, which enables each I/O pack to be replaced individually without affecting other I/O packs in the system. Additionally, the I/O pack may be replaced without disconnecting any field wiring.



Typical I/O Module with Box-type Terminal Block

TERMINAL BLOCKS

Signal flow begins with a sensor connected to a terminal block on an I/O module. The terminal board mounts to the cabinet and is available in two basic types: T-type and S-type modules.

T-type modules typically fan the inputs to three separate I/O packs. They contain two removable 24-point, barrier-type terminal blocks. Each point can accept two 3.0 mm² (#12,AWG) wires with 300 V insulation per point and spade or ring-type lugs. Captive clamps are also provided for terminating bare wires. Screw spacing is 9.53 mm (0.375 in) minimum, center-to-center. T-type modules are normally surface mounted, but may also be DIN-rail mounted.

A shield strip is provided next to each block, which is actually the left-hand side of the metal base where the module is mounted. Wide and narrow modules are arranged in vertical columns of high and low-level wiring that can be accessed from top and/or bottom cable entrances. An example of a wide module is a module containing magnetic relays with fused circuits for solenoid drivers.

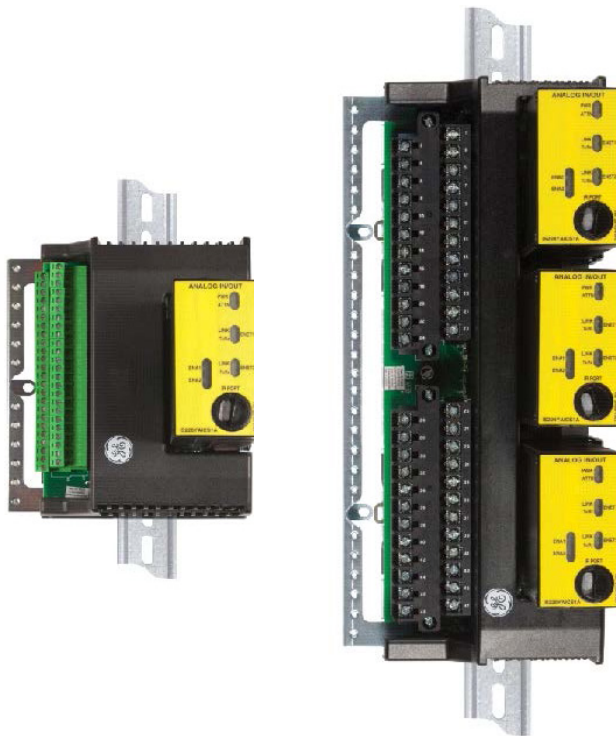

Box-type and Barrier-type Terminal Blocks in Simplex and Triple Redundant Configuration

S-type modules provide a single set of screws for each I/O point and allows a single I/O pack to condition and digitize the signal. This board is used for simplex, dual, and dedicated triple modular redundant (TMR) inputs by using one, two, or three boards. They are half the size of T-type modules and are DIN-rail or surface mounted. Two versions of the S-type modules are available: fixed terminal blocks and removable terminal blocks.

Fixed box-type terminal blocks accept one 3.0 mm² (#12 AWG) wire or two 2.0 mm² (#14 AWG) wires with 300 V insulation per point. Screw spacing is 5.08 mm (0.2 in) minimum, center-to-center. Removable box terminals may be replaced with spring-cage-clamp, insulation displacement, or crimp-and-stab terminals. A shield strip is provided on each terminal block and is tied to functional ground.

TEMPERATURE RATINGS

Mark VIe electronics are packaged in different locations world-wide and customized for a variety of protection classifications with and without ventilation and cooling. Controllers, I/O modules, power supplies, etc. are rated for -30 to 65°C (-22 to 149°F) at the electronics. To compliment the Mark VIe Control's native I/O modules, a variety of fieldbus solutions are available with master communication gateways on the I/O network. These modules have slightly reduced operating temperature ratings:

- PROFIBUS® Master Gateway: -20 to 55°C (-4 to 131°F)
- CANopen® Master Gateway: -20 to 55°C (-4 to 131°F)
- FOUNDATION Fieldbus™ Linking Device: 0 to 55°C (32 to 131°F)

Modules with reduced operating temperatures should be mounted lower in the cabinet to avoid the natural temperature gradient from the bottom to the top of the enclosure. Control room equipment such as operator stations has an operating temperature range of 20 to 30°C (68 to 86°F). For shipping and storage, the controllers, I/O modules, power supplies, etc. are rated -40 to 85°C (-40 to 185°F), and control room equipment is rated 0 to 30°C (32 to 86°F).

I/O MODULES

I/O modules can be categorized as generic and application-specific. As an example, discrete inputs (contact inputs) are used in virtually all applications and differ primarily in their voltage rating. Other considerations in selecting a module are its redundancy, isolation (group or point), terminal block type, availability for safety applications (IEC 61508), and approval for hazardous locations.

A typical application-specific module is a servo module that is used for fast closed-loop control of a turbine's servo valve actuator or a complete emergency over-speed trip system for a turbine. These unique modules will not be described in the following tables. However, some application-specific modules such as a vibration module is commonly applied in monitoring radial and axial shaft displacement of rotating machinery in plant distributed control systems and will be described in a separate table.

I/O modules are mounted in local clusters and distributed remotely for packaging in a variety of protection classifications. Therefore, temperature ratings are provided for the ambient at the electronics.

Discrete Input (DI) Modules with Sequence of Events (SOE)

Voltage	Qty.	Isolation	TB Type	Removable Term. Block	I/O Packs per Module	Safety Version Available	Hazardous Location Approval
24Vdc	24	Group Group Point	Barrier Box Barrier	Yes Yes or No Yes	1, 2, 3 1 1, 2, 3	Yes Yes No	Yes Yes No
48Vdc	24	Group Group	Barrier Box	Yes Yes	1, 2, 3 1	Yes Yes	No No
125Vdc	24	Group Group	Barrier Box	Yes Yes	1, 2, 3 1	Yes Yes	No No
115/230Vac, 125Vdc	24	Point	Barrier	Yes	1, 2, 3	No	No No
Optical isolation to 1,500 V on all inputs Specialty modules are available with wetting voltages and line break detection for 24, 48, 125, 250Vdc, and 115, 230Vac							

Discrete Input (DI) Modules with Sequence of Events (SOE)

- All inputs and outputs have Sequence of Events (SOE) monitoring
- All outputs use mechanical relays with dry form “C” contacts

DI Voltage	DI Qty.	Isolation	DO Qty.	TB Type	Removable Term. Block	I/O Packs per Module	Safety Version Available	Hazardous Location Approval
24Vdc	24	Group	12	Box	Yes	1 or 3	No	Yes
48Vdc	24	Group	12	Box	Yes	1 or 3	No	No
125Vdc	24	Group	12	Box	Yes	1 or 3	No	No
Optical isolation to 1,500 V on all inputs Options are available to add fuses via a selection of daughter boards.								

Discrete outputs are available on output-only modules and combination modules that house discrete inputs and outputs. Mechanical relays with dry form “C” contacts are most commonly used since they can be applied in AC and DC circuits with multiple voltage ratings, provide normally open and/or closed contacts, have no leakage current, and have the versatility needed for fusing, diagnostics, and suppression for solenoids. Various forms of built-in solenoid interface are available to eliminate the cost of external, customized fusing and suppression.

Most relays can be plugged and unplugged from their sockets for convenient maintenance, but this precludes their application in hazardous locations. A 24Vdc solid-state relay module is available for hazardous locations and two forms of mechanical relay modules with sealed relays. These mechanical relay modules also feature 2-out-3 contact voting from 36 relays resulting in 12 form “A” (normally-open) or form “B” (normally-closed) contact configurations. The more common form of relay voting has three I/O packs driving a voting relay driver on the module.

Discrete Output (DO) Modules

- All outputs have Sequence of Events (SOE) monitoring
- Additional specialty modules are available for hydraulic trip solenoid interface for specific turbine-types.

DO Qty.	Type	Contact Form	Diagnostics	†Solenoid Circuits Included	TB Type	Removable Term. Block	I/O Packs Per Module	Safety Version Available	Hazardous Location Approval
12	Mech.	Dry "C"	Coil: 115/230Vac, 24/48/125Vdc	6 0	Barrier Box	Yes Yes or No	1 or 3 1	Yes Yes	No No
12	Mech.	Dry "C"	Voltage: 115/230Vac, 125Vdc	6	Barrier	Yes	1 or 3	No	No
12	Mech.	Dry "C"	Voltage:24Vdc	6	Barrier	Yes	1 or 3	No	No
12	Mech.	Dry "A"	Solenoid impedance: 24/125Vdc	0	Barrier	Yes	1 or 3	Yes	No
12	Solid State	Type "A"	Voltage: 115/230Vac	0	Barrier	Yes	1 or 3	No	No
Voltage: 24Vdc			0	Barrier	Yes	1 or 3	No	Yes	
Voltage: 125Vdc			0	Barrier	Yes	1 or 3	No	No	
12 ^{††}	Mech.	Dry "A"	Voltage: 115Vac, 24/48/125Vdc	0	Barrier	Yes	3	Yes	Yes
		Dry "B"		0	Barrier	Yes	3	Yes	Yes

† Options are available to add solenoid interfaces and fuses via a selection of daughter boards.

†† 36 relays on board are 2/3 voted to form 12 voted outputs that are available in for "A" (NO) and form "B" (NC)

Analog Input (AI) and Analog Output (AO) Modules

- V/I designates a voltage / current input
- TC designates thermocouples
- RTD designates resistance temperature device

Qty.	Input Type	Input Isolation	Output Type	Output Isolation	TB Type	Removable Term. Block	I/O Packs Per Module	Safety Version Available	Hazardous Location Approval
+10 AI 2 AO	V / I	Group	0-20ma 0-20ma 0-20/0-200ma 0-20/0-200ma	Group Group Group Group	Barrier Box Barrier Box	Yes Yes or No Yes Yes or No	1 or 3 1 1 or 3 1	Yes Yes No No	Yes Yes No No
10 AI 2 AO	V / I	Point	0-20ma 0-20/0-200ma	Group Group	Box Box	Yes or No Yes or No	1 1	No No	No No
16 AO 8 AO			0-20ma 0-20ma	Group Group	Barrier Box	Yes Yes or No	1 or 3 ^{††} 1	No No	Yes Yes
12 12 24	TC TC TC	Group Group Group	N/A N/A N/A	N/A N/A N/A	Barrier Box Barrier	Yes Yes or No Yes	1, 2, 3 ^{†††} 1 1, 2 ^{††††}	Yes Yes Yes	Yes Yes Yes
16	RTD	Group	N/A	N/A	Barrier Box	Yes Yes or No	1, 2 ^{†††††} 1	No No	Yes Yes

[†] HART Communications is available

^{††} 8 AO outputs are driven by each of two I/O Packs

^{†††} Each TC is monitored by all 3 I/O Packs. Extended range option available for EPRI compliance.

^{††††} 12 TCs are monitored by each of 2 I/O Packs. Extended range option available for EPRI compliance

^{†††††} 8 3-wire RTDs are monitored by each of 2 I/O Packs

Analog I/O modules typically contain 10 analog inputs and 2 analog outputs. 8 inputs can be configured for 1-5Vdc, ±5Vdc, ±10Vdc, or 0-20ma with jumpers on the module, and the remaining 2 inputs can be configured for 0-20ma or +/-1ma with 250 Ω / 5,000 Ω burden resistors respectively. For applications with a high concentration of analog outputs, dedicated output modules are available for 0-20ma and others for 0-20ma / 0-200ma selection for valve actuators (800 Ω / 50 Ω output loads respectively). Transducers can be externally powered (differential inputs) or internally powered from the I/O module with +24Vdc current limited per point. I/O modules are available with point isolation for externally powered transducers.

In general, RTDs are useful for precision temperature measurements below 800°C, and thermocouples are cost effective devices for monitoring a wider temperature range. RTD modules provide a 10 ma multiplexed excitation current to each RTD, which can be grounded or ungrounded. They support 100 and 200 Ω platinum, 10 Ω copper, and 120 Ω nickel 3-wire RTDs with software linearization per point. The linearization includes scaling for specific RTD standards such as a MINCO-CA or CU10 10 Ω copper RTDs. RTDs can be located up to 300 meters (984 feet) from the I/O module with a maximum two-way cable resistance of 15 Ω.

Thermocouple modules are available for grounded or ungrounded type E, J, K, S, T, B, N and R thermocouples with linearization per point. A cold junction device is contained in each I/O pack, and modules with two packs average their cold junction readings provided the readings are within normal limits. In addition, remote cold junction compensation is supported. Thermocouples can be located up to 300 meters (984 feet) from the I/O module with a maximum two-way cable resistance of 450 Ω .

Fieldbus Modules

Communication Type	TB Type	Removable Term. Block	I/O Packs per Module	Safety Version Available	Hazardous Location Approval
PROFIBUS DP-V0 and V1 Master Gateway	N/A	N/A	1	No	Yes
FOUNDATION Fieldbus H1 to HSE Linking Device	N/A	N/A	1	No	Yes
CANopen Master Gateway	N/A	N/A	1	No	Yes
HART Communications: 10 V/I inputs and 2 (0-20ma) outputs	Box	Yes or No	1	Yes	Yes
(6) Serial channels : RS-232, RS-422, RS-485 half-duplex Support 6 Modbus serial and 1 Modbus Ethernet	Box	Yes or No	1	No	Yes

PROFIBUS DP Gateway

Mark VIe offers a PROFIBUS DP-V0 and DP-V1, Class 1 master that maps I/O from slave devices to the controllers.

Bus Performance

The gateway is an I/O module that communicates on the 100 MB Ethernet I/O network to the controllers and on an RS-485 interface to slave devices. It supports 9.6 KB to 12 MB communications for up to 125 nodes with 244 bytes of I/O per slave. Data can be communicated between the controller and the PROFIBUS I/O module as fast as 10 ms. Data is then asynchronously communicated to the slaves at the fastest possible rate, determined by the PROFIBUS network baud rate, slave quantity, I/O quantity, and slave response time. At a 10 ms execution rate (frame rate), 500 inputs and 500 outputs (half Boolean and half analog) can be processed. For input event detection, Boolean inputs can be configured for sequence of events (SOE) logging with 10 ms time tags. Analog data can be configured for point-to-variable data type conversion and scaling. Online downloads of control software are supported.

Redundancy

The gateway can be configured for three types of redundancy:

- One I/O module with one I/O network
- One I/O module with dual I/O networks
- HotBackup I/O modules with dual I/O networks

The active master communicates with the slaves while the backup master is in standby mode. The gateway supports automatic switchover in less than 200 ms if any of the following conditions occur:

- All master / slave communication is lost
- Master / controller communication is lost on both I/O
- Master is powered down

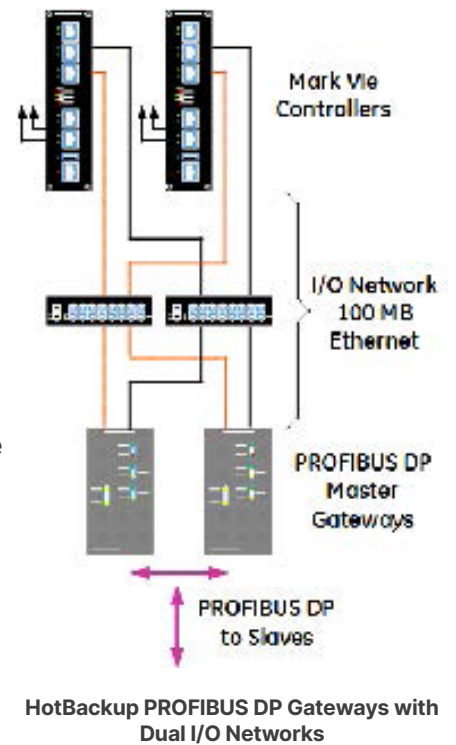

FOUNDATION Fieldbus

Fieldbus modules such as the FOUNDATION Fieldbus H1 to HSE Linking Device communicate on the Mark VIe IONet and are fully compatible with the ControlST software suite, which is a Class 61b Registered Host. ToolboxST software is used to configure and monitor fieldbus modules along with all devices at the I/O and supervisory levels.

For reliability, two linking devices can be connected with a RS-232C null modem cable to form one logical linking device (a redundant set) in a primary / secondary configuration.

Features

- 4 H1 ports with galvanic isolation (transformer)
- 16 field devices per segment
- IECTM 61158 compliant data link layer
- Access to device data, function blocks, and configuration from HSE
- Data republishing from H1 to HSE or between H1 links
- Redundant and non-redundant configuration
- Each H1 channel can be a Link Master or Time Manager

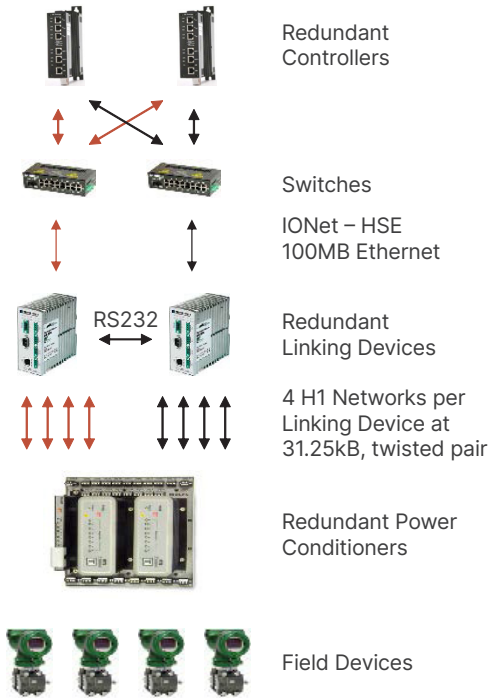

FOUNDATION Fieldbus Redundant H1 to HSE Linking Device and Power Converters

Vibration / Proximator* Module

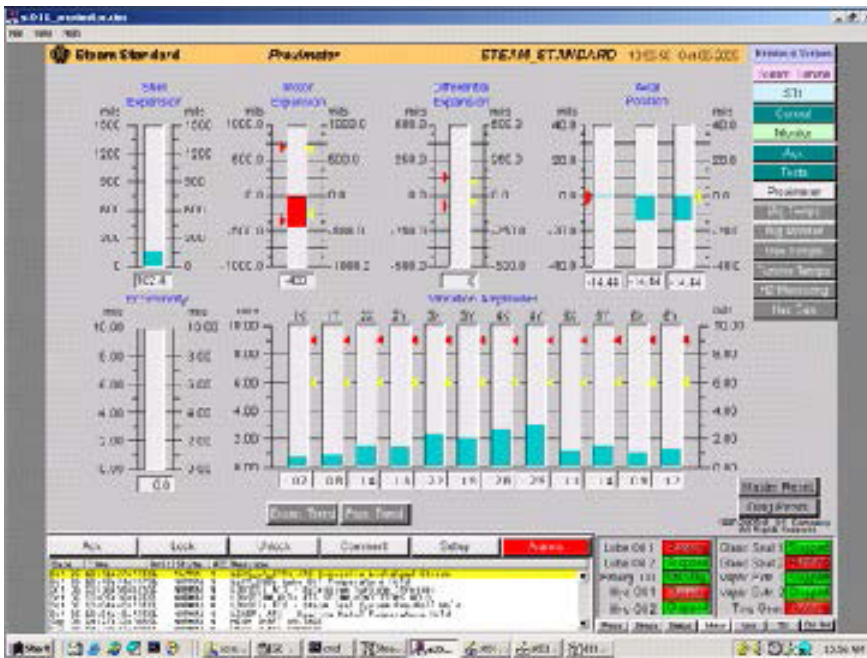

Typical Monitoring of Shaft Vibration, Axial Position, Expansion, and Eccentricity

The vibration module that is used in turbine-generator applications is also commonly used for shaft position monitoring of rotating machinery in balance of plant (BOP) applications. It supports accelerometers (channels 1-3), seismic / velocity sensors (channels 1-8), Velomitors* (channels (1-8) , and Proximitors (channels 1-13). When a Proximitor is used to monitor a rotating machine's radial vibration, it is restricted to channels 1-8, which analyze the signal's AC component, including 1X and 2X frequencies, for vibration and DC component for the probe's displacement gap. Channels 9-13 monitor the DC component only.

The module provides -24Vdc transducer power with current limiting per point. Buffered outputs are available to access real-time sensor signals while the equipment is running.

Channels	Sensor Compatibility	Channel Isolation	TB Type	Removable Term. Block	I/O Packs Per Module	Safety Version Available	Hazardous Location Approval
1-3 1-8 1-8 1-8 1-13 13	Accelerometer Proximitor Seismic Velomitor Position Keyphasor*	Group	Barrier	Yes	1, 2, 3	Yes	Yes

IONET

The controller and I/O modules communicate over the IONet, a 100 MB Ethernet network that is available in non-redundant, dual redundant, and triple redundant configurations. Ethernet Global Data (EGD) and other protocols are used for communication. EGD is based on the UDP/IP standard (RFC 768). EGD packets are broadcast at up to the system frame rate from the controller to the I/O modules, which respond with input data. IEEE 1588 Precision Time Protocol is used on the IONet to time-align the I/O pack data.

Switches manage the communication traffic to eliminate collisions and increase network determinism. There are no Ethernet collisions on the IONet.

Specifications

Item	Description
IEEE Specifications	802.3u
Wire Speed	100 Mbps
Cable Type	UTP Cat 5e and fiber (multi-mode and single mode)
Connector Type	RJ-45 and SC (fiber)
Max. Length of Segment	100 m (328 ft.) and 2 km (6,600 ft.) with fiber
Max. Taps / Segment	2
Max. Packets / Network	199
Max. Switches	5
Topology	Star

Shared IONET

I/O modules from two different applications can share their data on the same IONET with two different sets of controllers. As an example, sensor data that is being monitored by a Safety Controller can be shared with a Balance of Plant controller to simplify the design and reduce the cost of instrumentation. Controller outputs are restricted to the I/O modules designated for their specific application and not shared.

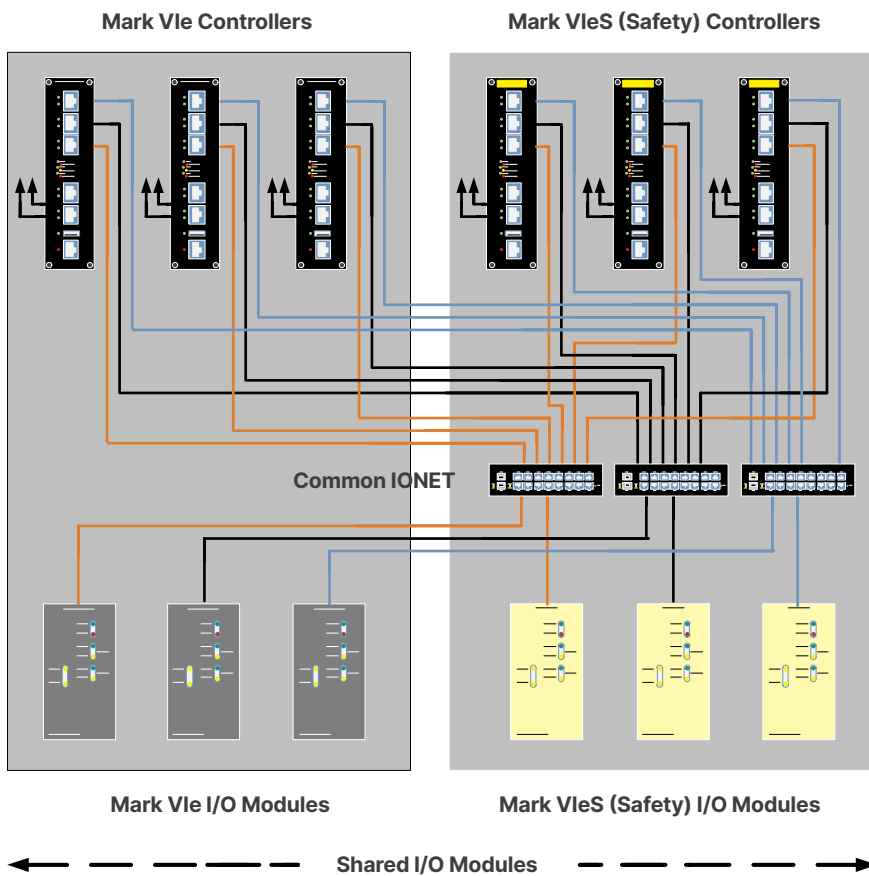

Switches manage the communication traffic to eliminate collisions and increase network determinism. There are no Ethernet collisions on the IONet.

Peer-to-Peer I/O Level Communications

Local processors in I/O modules can communicate data peer-to-peer with local processors in other I/O modules without the latency of communicating with the main controller. As an example, Power Load Unbalance is used on large steam turbines to quickly close control valves and intercept valves during a load rejection that might lead to rapid acceleration. One I/O module compares the turbine mechanical power (analog inputs) with the generator load (current transformer inputs) and quickly commands the valves to close via a peer-to-peer transmission to the I/O module that controls the valves.

Direct communications between I/O modules enables quicker control response to process transient conditions.

CONTROLLER

The controller is a compact and flexible design for processing and network communications.

Features

- Frame rate: 10, 20, 40, 80, 160, or 320 ms
- Speed
 - UCSBH1A: 600 MHz
 - UCSBH3A: 1200 MHz
- Ports: 5 Ethernet, 1 USB, 1 COM
- Configuration: Simplex, dual, triple
- Power: 18 to 32 V dc
- No batteries
- Status LEDs
- Cooling
 - 600 MHz (convection)
 - 1200 MHz (redundant fans)
- Safety: IEC-61508 compliant
- Security: Achilles™ certified - Level 1

Environment

- Operating temperature:
 - UCSBH1A: -30 to 65°C (-22 to 149 °F)
 - UCSBH3A: 0 to 65°C (32 to 149 °F)
- Humidity: 5 to 95% non-condensing

For dual and triple redundant systems, a second and third controller can be mounted adjacent for a compact packaging arrangement. Local LEDs are provided on the controller to indicate the status of: Link, Act, Power, Boot, OnLine, Flash, DC, Diag, and On (USB).

Each controller has three 100 MB Ethernet interfaces for the I/O network so that each controller can communicate with up to three IONet networks. In redundant systems, this allows each controller to monitor redundant inputs directly and compare them for any potential discrepancies. Connectors are labeled to simplify maintenance.

Controllers also have two Ethernet interfaces to the control network to communicate peer-to-peer with other Mark VIe-based control systems, as well as operator and maintenance stations. Controllers can be time synchronized between units or to a local or remote time source for accurate plant-wide sequence of events (SOE) monitoring.



CYBERSECURITY

As a global leader in automation and control, GE provides cyber security management as an inherent feature of the Mark VIe control family. It assists with the implementation of effective security policy to ensure system confidentiality, integrity and availability, providing real-time change monitoring and audit capabilities. Security measures include:

- Cyber-hardened control system components
- A set of best-in-class security features
- A software patch service

Secure Configuration

The security system provides secure operations that are aligned with key industry best practices. It supports the reliability, availability, integrity, and maintainability of a plant's control infrastructure and enables plant compliance with cyber security regulations and standards.

Secure Network Architecture

- The first layer guards against unauthorized network access. Administrative access to network devices is controlled with a centralized access and account management tool, Microsoft® Active Directory® Domain Services with RADIUS.
- The second layer monitors firewall and network traffic for known cyber-attack patterns and abnormal traffic with an Intrusion Detection System.
- The final layer is at the network switches, which are cyber hardened according to National Security Agency guidelines. Only ports and services that are necessary for normal and emergency operations are enabled.



Features

- Easy integration into the broader plant-level security
- Network segmentation
- Centralized role-based account management
- Public Key Infrastructure for controller protection
- Appliance-based Network Intrusion Detection systems
- Security information and event management
- Enterprise virus and malware detection, and quarantine
- Hardened HMIs, controllers, and network switches
- Compliance Reporting
- Backup and Recovery
- Software update service

Secure Controller Operation

Command and control of plant equipment is protected by layers of security measures in the controller and the controller's interface. Access is restricted to authorized users, and security certificates provide two-way authentication. Controller protection includes operating system hardening, a native whitelisting function, and a code integrity checker that allows only authenticated code to be installed and run. Third party certification is provided by the Achilles™ Communications Certification Program – Level 1.

Secure HMI Operations

The Microsoft Active Directory Domain Services with RADIUS enforces the security policy on each HMI to prevent unauthorized user access and unauthorized configuration changes. Weak and default passwords are detected and prohibited. After authentication, a user is assigned the least privilege necessary for their assigned role, and all privilege escalations are logged.

Ports, services, and installed applications on each HMI are reduced to those required for normal and emergency operations only. Windows 7 and Windows Server® 2008 R2 operating systems have been cyber-hardened using industry security best practices and industry standards

Security Information and Event Management (SIEM)

SIEM continuously collects events from control system components, network devices, and security equipment and stores them in a centralized location. This enables disparate and time-separated events to be analyzed for potential security threats. A reporting tool is provided to assist in compliance and regulatory reporting.

Anti-virus Patch Management

Anti-virus and malware protection detects and removes viruses, spyware, rootkits, Trojans, and adware to defend against security-related attacks. HMI malware protection is managed from a central console, which provides a dashboard to monitor the protection status, and manage updates. Connection to the Internet is not required to receive updates.

Security Patch Service

Regular releases of security patches is a best practice. Customers can choose which patches to deploy, to what equipment, and when. A console provides a comprehensive status update, and patch reports document US-CERT criticality, compatibility, estimated install time, and whether a restart is required.

CONTROLST SOFTWARE SUITE

The ControlST software suite is applied on GE’s wide range of controls applications. It includes several high-performance tools used by operators and maintenance personnel for communications, monitoring, and asset management, including:

- WorkstationST* HMI and Historian management application
- ToolboxST* configuration and diagnostics application
- CIMPLICITY* graphics tools

HUMAN-MACHINE INTERFACE (HMI)

The HMI is a Windows-based operator station and engineering workstation.

The HMI may be applied as a stand-alone operator station, an engineering workstation only, or both. Physically, it is available as a commercial grade or industrial grade computer. It communicates on an Ethernet control network and on a separate Ethernet information network for file transfers and communications to non-GE plant control and monitoring systems.

Redundant HMIs and Ethernet networks are available for increased operations and communications reliability. However, vital control and protection functions are processed by the controllers and not in the HMI to mitigate risk to equipment operation and availability. Similarly, high-accuracy time stamping of alarms, events, and SOEs is performed in the controllers (to obtain the best resolution) and transmitted to the HMI. Alarm state is also maintained in the controller.

ToolboxST configuration and diagnostics software can also be loaded onto a laptop computer.

Feature	Operator Station	Maintenance Station	Engineering Workstation	Engineering Workstation
Operator Screens	Standard	Option	Standard	
Alarm / Event Viewer	Standard	Standard	Standard	Option
Recorder / Logging	Standard	Standard	Standard	
Trending	Standard	Standard	Standard	
Logic Viewer		Standard	Standard	
Configure Screens		Option	Standard	
Configure Hardware		Option	Standard	
Configure Software		Option	Standard	
Configuration Management			†Standard	Option
Alarm / Event Server			Option	Option
Communications: Modbus®, OPC® DA, OPC AE, GE Standard Messaging (GSM)	Option	Option	Option	
Plant and Device Asset Management			Option	

† Configuration management for up to 9 clients

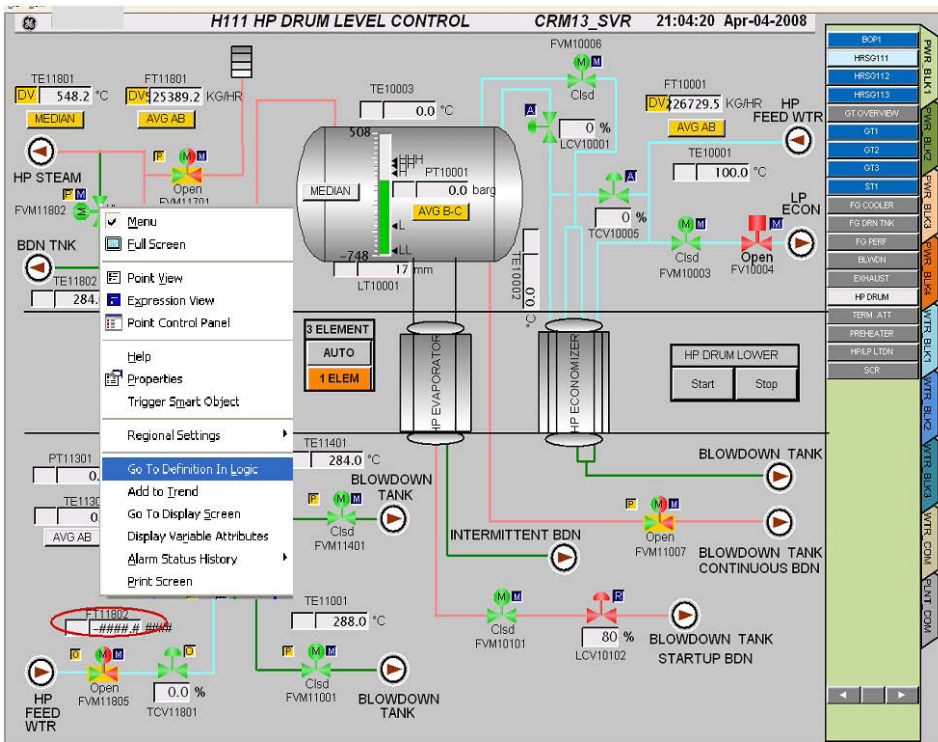

Typical HMI Operator Screen

WORKSTATIONST HMI AND HISTORIAN SOFTWARE

The WorkstationST application provides the foundation for the operator experience with integrated graphics tools. It allows for management of alarms, events, logging, historical data, networks, web interface, and other control system functions. This cohesive package is exemplified by a simple operator right-click on a screen point that displays a shortcut menu with convenient navigation to related alarm history, trends, point information, logic diagrams, and so forth.

Key features include:

- Alarm Server and Alarm Viewer provide:
 - Access to live and historical alarms and events
 - Filtering and statistical analysis including Pareto charts and summary views
- OPC AE Server provides access to external OPC AE clients for viewing alarms and events. Refer to GEI-100624, WorkstationST OPC AE Server.
- OPC DA provides access to external servers and clients. Refer to GEI-100621, WorkstationST OPC DA Server Installation Guide.
- OPC UA combines the older standards of OPC DA, OPC AE, and OPC HDA into one interface and provides historical alarm and event access. Refer to GEI-100828, WorkstationST OPC UA Server Instruction Guide.
- Internal Historian (Recorder) provides short-term data storage and retrieval. Refer to GEI-100627, WorkstationST Recorder User Guide.
- External Historian interface configures OSIsoft PI to collect data from the OPC DA server.
- HMI configuration provides CimView screen interface with right-click command for adding variables to trends, viewing live data values, and configuration.
- Device Manager Gateway enables communication between a third-party asset management system and fieldbus devices. The gateway handles FOUNDATION fieldbus, HART, and PROFIBUS devices.
- Modbus communications provide serial master/slave and Ethernet interfaces.
- Network Time Protocol (NTP) for synchronization.
- Security system with user assigned roles.

Refer to GEI-100626, WorkstationST Alarm Server Instruction Guide and GEI-100620, WorkstationST Alarm Viewer Instruction Guide.

Alarm Management Tools

A flexible alarm management toolset based on ANSI/ISA-18.2 Management of Alarm Systems for the Process Industries assists the user in improving the safety, quality, and productivity of plant equipment. Embedded WorkstationST and ToolboxST applications provide a user-friendly environment for visualization, navigation, change management, and analysis of alarm and event conditions with a common, time-coherent data set for the plant.

Data Collection

To achieve the best time-resolution for analysis, alarms and events are initiated and time-stamped in the application software running in the controller. There are five types of alarms and events:

- Process alarms
- Control diagnostic alarms
- Events
- Sequence of Events (SOE)
- Holds in the startup sequence

SOE is a special category of events that provides high-resolution time-stamps for contact inputs on the order of $\pm 1\text{ms}$, which are particularly useful in power plants where trips can originate from electrical equipment and grid dynamics. In most cases, all contact inputs in Mark VIe control systems may be enabled for SOE monitoring, which provides a large source plant data for analysis to compliment traditional alarm management data.

Data is also collected from WorkstationST servers and third-party OPC Alarm and Event (AE) servers. This data is available for communication to alarm viewers and archiving in historical files.

Data Visualization

The value of the alarm system depends on the amount and quality of process data collected, and the manner that it is presented to the user. Alarm states are presented with audible and visual attributes in accordance with ANSI/ISA-18.2.

Alarm State Attributes

Alarm State (ControlST release V04.04)	Audible Indication	Visual Indications	
		Color	Blinking
Normal	No	No	No
Unacknowledged	Yes	Yes	Yes
Acknowledged	No	Yes	No
Return to normal state unacknowledged	No	No	No
Latched – unacknowledged alarm	Yes	Yes	Yes
Latched – acknowledged alarm	No	Yes	No
Out-of-service alarm	No	Yes	No
Shelved alarm	No	Yes	No

Audible alarm features are available to compliment visual displays with Tone, Wave File, and Voice attributes. The alarm system monitors the highest priority alarm that is active, unacknowledged, and not silenced, and plays the sound for that alarm. If Text To Speech is selected, an audible announcement of the alarm priority, type, and description is provided. For example, Priority 1, Process Alarm, Gas Auxiliary Stop Position Filter Pre-Ignition Trip could be announced, if applicable.

In addition to alarm states, there is a vast amount of alarm information available for analysis. To enhance notification, Alarm Properties may be selected from a large menu and sorted.

To simplify visualization, filters are provided for both real-time and historical data. Filter collections can contain one or more filters, and each filter can contain one or more Alarm Properties. For example, the Plant Area filter is used to filter alarms and events based on the area of the plant where the alarm occurred. This filter can be combined with the Priority filter to pass-through alarms and events based on location and priority.

Alarm Rationalization

During the rationalization stage of the alarm management life-cycle, existing and potential new alarms are systematically evaluated to the criteria in the alarm philosophy. If the alarm meets the criteria, the alarm set-point, consequence, and operator action are documented, and the alarm is prioritized and classified according to the alarm philosophy.

Alarm List - Priority

LAHH103, LT103

Base Response On	Priority Level	Medium	Operator Urgency [C0]: Minimal / None [C1]: Minor [C2]: Major [C3]: Severe				
<input checked="" type="checkbox"/> Alarm Enabled	Imported Priority	Most Urgent	[R0]: > 30 Minutes	No Alarm	No Alarm	No Alarm	No Alarm
1 - Safety Impact	[C3] 1-4 Fatalities		[R1]: 5-30 Minutes	No Alarm	Least Urgent	Least Urgent	Medium
2 - Health	[C1] Moderate Illness		[R2]: 1-5 Minutes	No Alarm	Least Urgent	Medium	Medium
3 - Environmental	[C1] Long term, local effects		[R3]: < 1 Minutes	No Alarm	Medium	Most Urgent	Most Urgent
4 - Assets	[C2] Serious Loss Cost: \$1M < \$10M		<input type="checkbox"/> Override Priority				
Operator Urgency	[R2] 1-5 Minutes						

Logging	0	0%	Most Urgent	1	4.0%
Least Urgent	11	52.4%	Critical	1	4.8%
Medium	8	38.1%			

Alarm Prioritization Based on Consequences and Time-to-respond (SILAlarm™)

An advanced rationalization tool, SILAlarm from exida LLC, is available for integration with the ControlST software suite to support and document the results of the rationalization process in a master database. It systematically guides plant personnel through the process of reviewing, justifying, and documenting the design of each alarm, including the following:

- Evaluation of consequences and time-to-respond
- Prioritization
- Document the cause, consequence, confirmation, corrective action, and so forth
- Classification
- Set-point limit determination
- Settings of dead-bands and on/off time delays
- Alarm suppression/advanced alarming
- Functional safety management
- Routing of alarm messages

Reports

Configurable alarm report tools provide guidance for alarm analysis.

An Alarm Performance Metric Report summarizes the key performance metrics and their actual values compared to their target values based on at least 30 days of data. For convenience, configuration of all metrics in the report can be instantly set to a pre-defined set of default values with a single command, or the configuration can be customized.

Individual reports are available for Alarms Per Day, Alarms Per Hour, and Alarms Per 10 Minutes with any combination of the five alarm/event types. For each report, the data may be displayed in a tabular format showing the quantity of occurrences for each alarm during the specified period of time. Also, a bar or pie chart may display the alarm quantities and the percentage of alarms above and below a threshold level.

An Alarm Flood occurs when alarms are generating at a faster rate than the operator can effectively manage them. ANSI/ISA 18.2 defines an alarm flood period as more than 10 alarms occurring in a 10 minute period. The Alarm Flood report enables configuration of the number of alarms to begin a flood condition (normally > 10), to end a flood condition (normally < 5), and the time interval (normally 10 minutes). A tabular report displays the quantity of alarms during each alarm flood, the alarm/event type, the start time of the flood, and its duration. A supporting pie chart displays the number of alarm floods and the percentage of floods allocated to each of the five alarm/events types.

The Top Most Frequent Alarms report identifies which alarms occur most often with a table, a bar chart, and a pie chart report for a specified period of time. Additionally, the pie chart displays the percentage of the overall alarm load being allocated to the 10 most frequently occurring alarms.

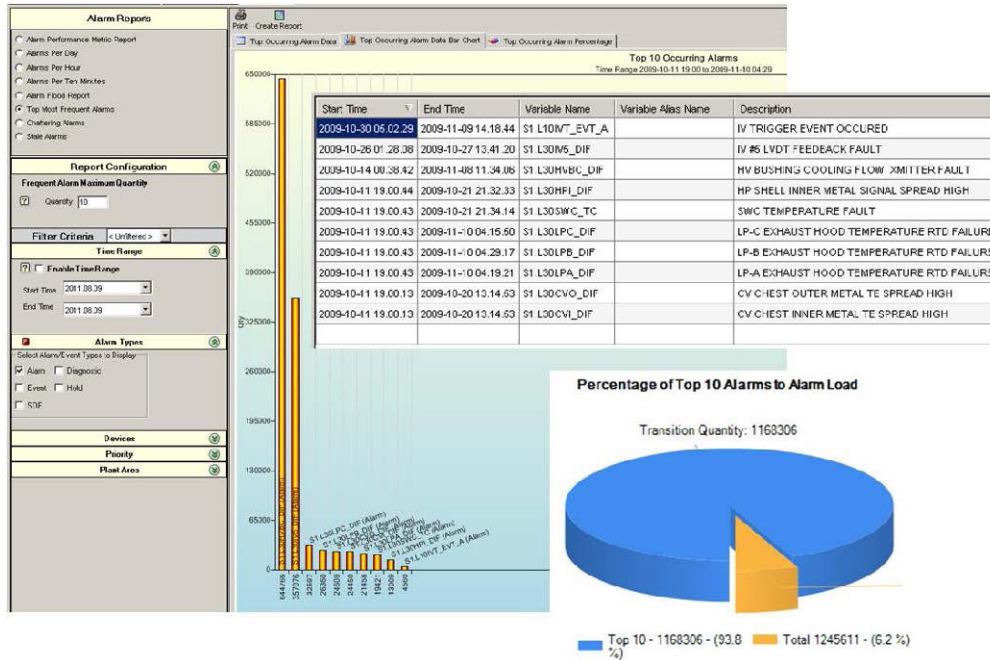

Top Most Frequent Alarms Reports

Chattering Alarms transition between alarm states in a short period of time (typically three times in one minute) that are not related to operator actions. These nuisance alarms are problematic since they are often the most frequently occurring alarms in a plant. A table and bar chart provide information on chattering alarms.

Stale Alarms remain in the alarm state for more than 24 hours and usually provide minimal useful information. Table and bar chart reports are provided for stale alarms.

Alarm Help

The alarm management system provides user help messages for process and control diagnostics alarms. Help is accessed through a browser by selecting an individual alarm and selecting the Help button, or through the Help item in a display menu. To expedite troubleshooting, each alarm help message identifies the possible cause(s) of the alarm and a recommended corrective action (solution). Standard alarm help messages are provided for control diagnostic alarms related to abnormal conditions in the control platform, such as a relay failure. Process alarm help messages are available for selected turbine and plant configurations.

Basic Operator Actions and Navigation

A live alarm toolbar simplifies the selection of operator commands and navigation between the alarm management tools and associated tools such as the ToolboxST System Editor. Also, a simple right-click in a display area provides a shortcut menu with additional options. For convenience, unavailable operator actions are listed with subdued coloring to indicate actions that are not suitable for the current alarm state.

Operator Actions for All Displayed Alarms (No Selection Required)

Menu Item	Operator Action
Acknowledge All On Screen	Acknowledges all alarms that are currently visible on the screen
Reset All on Screen	Resets all alarms that are currently visible on the screen
Silence All On Screen	Suppresses the sound being annunciated for all alarms that are currently visible on the screen

Operator Actions for Selected Alarms

Menu Item	Operator Action
Acknowledge	Acknowledges the selected alarm set
Unacknowledge	Removes the acknowledged condition on the selected alarm set
In Service	Returns the selected alarm(s) to In Service
Out-of-service	Places the selected alarms Out-of-Service
Lock	Prevents the selected alarm set from changing
Unlock	Unlock Releases the Lock from the selected alarm set
Override	Overrides the alarm of the selected alarm set
Remove Override	Removes the override attribute of the selected alarm set
Reset	Resets the selected alarm set
Silence	Silences the selected alarm set
Unsilence	Reinstates the sound attribute of the of the selected alarm set
Silence Alarms Horn	Silenced the alarm horn of the selected alarm set
Shelve	Places the selected alarm(s) in the Shelved state
Un-shelve	Returns the selected alarm(s) to normal operation

Operator Navigation and Support Features

Menu Item	Operator Action
Alarm Attributes	Displays alarm attributes for the selected process alarm
Alarm Help	Provides process and control diagnostic alarm help. Refer to the section, Alarm Help.
Alarm Status History	Retrieves the set of historical alarms for a selected time period and filter criteria
Copy Selection	Copies the selected alarms into the clipboard so they can be pasted into Word® or Excel®
Create Filter from Selection	Creates a filter from a set of alarms and events
Display Variable Attributes	Displays a data grid with the selected alarm variable attributes
Go To Definition in Logic	Navigates to the application software block where the alarm variable originates for the selected alarm
Go To Display Screen	Navigates to the screen containing the alarm variable for the selected alarm
Print Alarms	Prints all alarms that are currently displayed or could be displayed if scrolled into view

TOOLBOXST CONFIGURATION AND DIAGNOSTIC APPLICATION

The ToolboxST application provides a common configuration tool for hardware and software from I/O modules and controllers to operator stations. This simplifies system configuration and enhances troubleshooting with an advanced set of diagnostics tools to analyze a common system-wide data set. The ToolboxST application is packaged with the ControlST software suite, but may also be provided as a single application.

Common configuration and diagnostic tools with a common dataset simplify maintenance and training.

Key features include:

- Software editors with drag-and-drop operation for points to graphics
- Trending for graphing real-time and historical data with advanced analysis features, such as Fast Fourier Transforms (FFT)
- Block diagrams with embedded ladders — Scientific Apparatus Makers Association (SAMA)-type formats and Sequential Function Charts (SFC) are available.
- Block libraries for specific applications, such as turbine and plant controls
- Configuration Management System for revision control and history tracking
- Configuration of hardware and software
- Diagnostic displays and messages
- Search tools (such as Finder) for locating text, overrides, differences, and variables

Trender

The Trender tool is used to capture and display graphs of variables in real time from controllers and other sources. High-speed time-coherent data can be collected from the Mark VIe, Mark Ve, Mark VI, EX2100e, and LS2100e controllers at their execution rate (frame rate) with sub-millisecond resolution from power converters. Data sets may also be received through OPC HDA from a Historian such as PI Server™, OPC-DA servers, or static files stored on a hard disk in the following form: data collection and analysis (.dcaST), comma separated value (.csv), COMTRADE, and Control System Solutions (toolbox) Trend Recorder (.trn).

Graph View displays trend values represented by each configured trace

Property Editor allows you to change settings that affect the capture and display of data

Toolbar contains buttons to perform commands

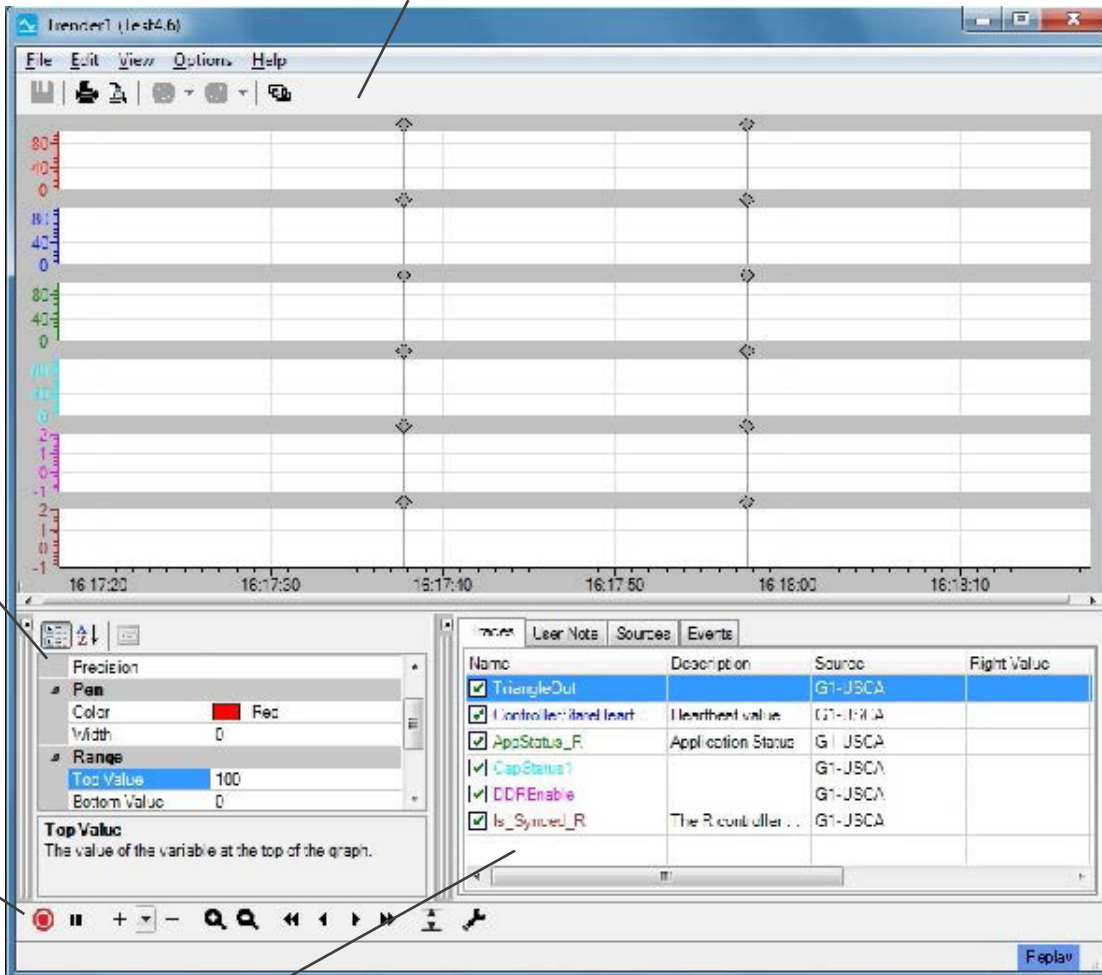

Auxiliary View contains tabs that display information about the current data

Traces tab displays all trending variables

User Note tab allows you to save comments, instructions, or notes about the current chapter

Sources tab displays sources where data is collected

Events tab lists all events that have occurred during the current chapter

Viewing Data

Once a trend window is opened, additional variables may be added to the trend using the drag-and-drop operation from logic diagrams and a right-click from operator screens. If the point has been configured as a historical collection point, the trend backfills with data from the historical data file.

If there are more traces than can be conveniently viewed, individual traces may be hidden. Data is still collected, but the traces are not displayed in the Graph View. Multiple traces can be displayed in a single graph or displayed individually with stacked graphs and a common time axis for analysis. Grid lines and data point markers on the x-axis can be superimposed on graphs to assist readability, including unique marker colors for alarm and event types. For data sets that are frequently trended, user-configurable files may be created and stored to provide pre-configured, on-demand trends.

Automatic Data Collections and Trends

The system can automatically collect groups of variables directly from controllers using the Dynamic Data Recorder (DDR). The user defines an event and time deadband to capture data with up to 96 variables per DDR. Data is captured at the controller's frame rate, with up to 12 DDR data sets per controller.

DDRs are used for troubleshooting or monitoring special events.

Trip Logs

Trip logs are defined as part of GE's standards for each machine controlled. When a trip occurs (the event), values of key control parameters are captured before and after the trip for evaluation. Data collected near the trip event is sampled at frame rate since these values are of greatest interest. Data collected earlier is sampled at progressively longer intervals.

Statistical Calculations

Trender can calculate a set of basic one-variable descriptive statistics for collected data while in the Replay mode. These statistics are calculated from data displayed between two cursors, and include average, standard deviation, RMS, minimum, maximum, and difference (calculated as final-initial). The calculated values are displayed as columns on the Traces tab when enabled.

Spectral Analysis

Spectral analysis quickly isolates the most common frequencies of data fluctuations by changing time-domain data into frequency-domain data, also referred to as a Fast Fourier Transform (FFT). The FFT tool features include:

- Between Cursors is applied to data values (left and right), which can be positioned inside the Graphics window.
- Padding Factor interpolates data values between actual data and copies of the same data, which enhances the spectrum resolution.
- Remove Mean improves data scalability for visualization.
- Windowing Modes are provided with different tradeoffs between analyzing similar strength signals with similar frequencies and dissimilar strength signals with dissimilar frequencies. These modes include: None, Hann, Hamming, Barlett, and Welch.

Diagnosis of complex problems on rotating machinery requires advanced trending tools.

Statistical Calculations

Plant personnel can configure hardware and software in controllers, remote I/O modules, and operator stations with the ToolboxST Block Diagram Editor.

To assist readability, control software is often represented in a SAMA-type format with a customizable border containing grid coordinates and a footer. Users may select automatic layout of diagram sheets with new sheets added, as needed. This feature is especially convenient for small and medium size applications. A manual layout mode is also provided for customizing sheet layouts to specific documentation requirements.

Software blocks can be selected from application-specific libraries and displayed with their dynamic values, variable names, or pin connections. Users can toggle between these three modes as needed. If inputs and outputs are not used in the configured mode, they are hidden on large blocks to reduce information clutter. These wires can be changed using the drag-and-drop operation to move a wire to a point on another block. The block diagram display ensures that the new wiring / programming will be changed correctly (going to the intended point).

The animation of the wiring between blocks and the functional representation of the blocks helps users to understand their current effect on the process. Line patterns signify analog versus Boolean data. Line colors indicate good versus bad data quality, and forced versus unforced data.

Animation is also provided for the functional representation of certain software blocks to display the current operation. For example, Interpolation blocks display the current (x, y) value and interpolation curve, and motor operated valve (MOV) blocks display the current status of the MOV.

Sequential Function Charts (SFC)

SFCs are widely used graphical programming models for defining the operational flow of a process. SFCs offer a convenient programming environment for plant startup and shutdown, as well as other sequencing to simplify programming, reduce maintenance, and assist troubleshooting.

The SFC control software is displayed in a flow chart format that represents the sequential operation of plant equipment. Standard programming rules, in compliance with IEC 61131-3, provide a disciplined approach to programming, yet offer complete flexibility in the configuration of simple steps, transitions, and actions.

SFCs are ideal for complex, plant, sequential control.

Hold Condition	Advances sequence independent of transition state
Single Step Mode	Transition conditions and user acknowledgement of implicit holds on all transitions for sequence progress
Free Running Mode	Transition conditions and user acknowledgement of operator holds (if applied to transitions) for progression
Pause / Continue SFC	By user input
Reset SFC	User input resets SFC to initial step
Actions of Interest	Sequence progresses after action complete confirmation

SFC graphics are displayed with the standard ToolboxST screen layout, providing a summary view of all SFC components interconnected and animated for easy status identification. Size limitations include:

- 256 steps
- 256 transitions
- 32 (typically 2 to 5 wide) divergent and convergent paths

For very rare complex applications, an SFC can be started from another SFC, allowing sectioning into multiple charts.

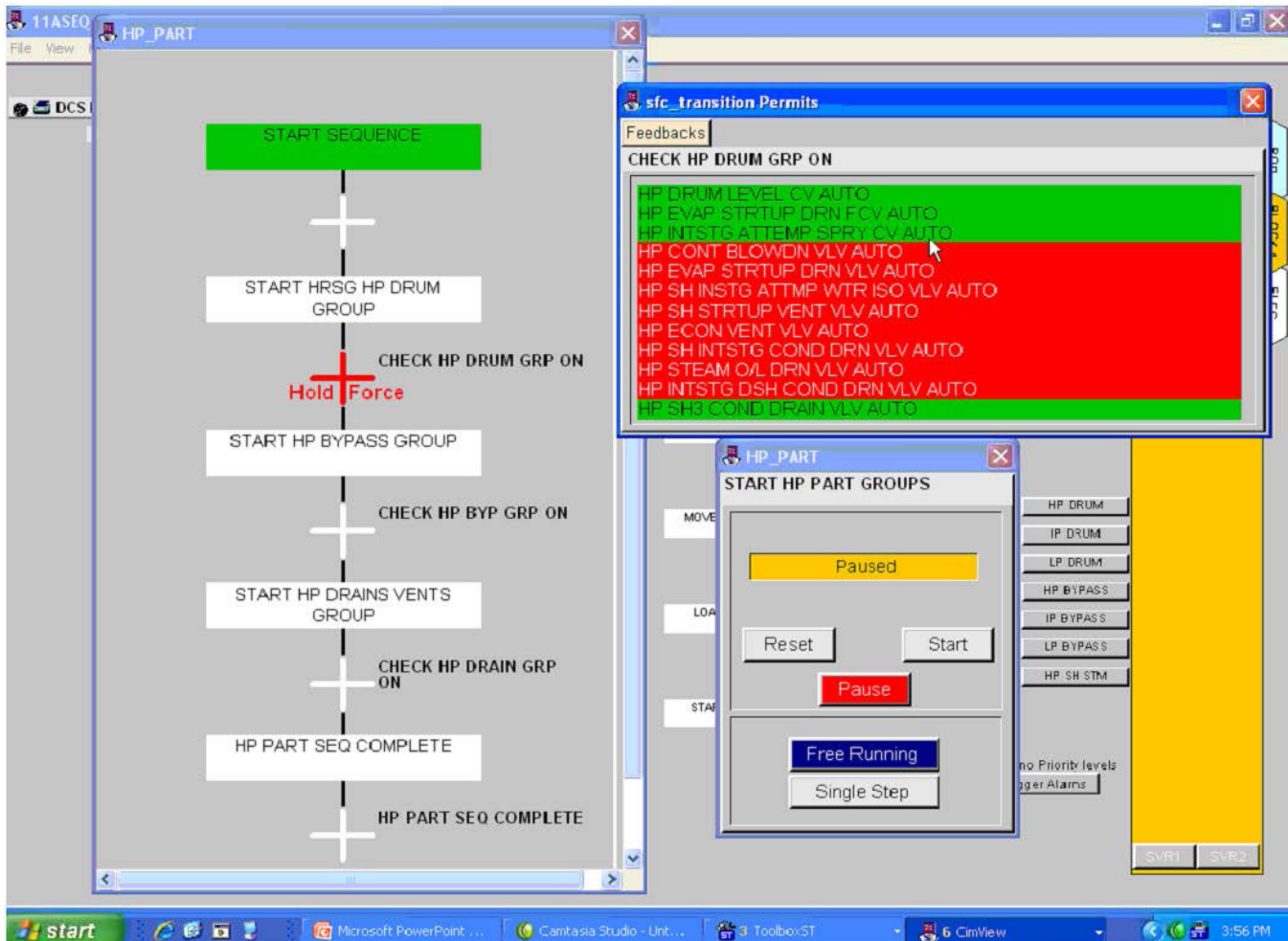

Sequential Function Chart

TECHNICAL REGULATIONS AND STANDARDS

Feature	Operator Station
Safety Standards	<p>EN 61010-1 Safety Requirements for Electrical Equipment for Measurement, Control, and Laboratory Use, Part 1: General Requirements</p> <p>CAN/CSA 22.2 No. 61010-1-12, UL 61010-1 Safety Requirements for Electrical Equipment for Measurement, Control, and Laboratory Use, Part 1: General Requirements</p> <p>IEC® 60529 Intrusion Protection Codes IP20 minimum (NEMA 1)</p>
Circuit board assemblies	<p>UL 796 Printed Circuit Boards</p> <p>ANSI IPC Guidelines</p> <p>ANSI IPC/EIA Guidelines</p>
Electromagnetic Compatibility (EMC) Directive 2004/108/EC	<p>EN 55011 Radiated and Conducted Emissions</p> <p>EN 61000-6-2 Generic Immunity Industrial Environment</p> <p>IEC 61000-4-2 Electrostatic Discharge Susceptibility</p> <p>IEC 61000-4-3 Radiated RF Immunity</p> <p>IEC 61000-4-4 Electrical Fast Transit Susceptibility</p> <p>IEC 61000-4-5 Surge Immunity</p> <p>IEC 61000-4-6 Conducted RF Immunity</p> <p>IEC 61000-4-11 Voltage Variation, Dips and Interruptions</p>
Low Voltage Directive 2006/95/EC	<p>EN 61010-1 (3rd edition) Safety Requirements for Electrical Equipment for Measurement, Control, and Laboratory Use, Part 1: General Requirements</p>
Hazardous Locations (Application-specific)	<p>Typical:</p> <p>ATEX Class I, Division 2, Groups A, B, C, D T4</p> <p>Class I, Zone 2, AEx nA IIC T4, Ex nA IIC T4 Gc X</p> <p>Ex nA IIC T4 Gc</p>
Functional Safety (Mark VIeS Safety Controller)	<p>IEC 61508:2010 Parts 1-7</p> <p>EN50402:2005+A1:2008 Logic Solver</p> <p>Systematic Capability: SC 3 (SIL 3 Capable)</p>
Quality Management System	<p>ISO 9001:2008 (FM590980) for "The design, manufacture, supply and service of programmable control, input/output, operator interface, software, and embedded computing products."</p>



GE VERNOVA

governova.com

* Indicates a trademark of General Electric Company and/or its subsidiaries. All other trademarks are the property of their respective owners.

We would appreciate your feedback about our documentation. Please send comments or suggestions to controls.doc@ge.com

These instructions do not purport to cover all details or variations in equipment, nor to provide for every possible contingency to be met during installation, operation, and maintenance. The information is supplied for informational purposes only, and GE makes no warranty as to the accuracy of the information included herein. Changes, modifications, and/or improvements to equipment and specifications are made periodically and these changes may or may not be reflected herein. It is understood that GE may make changes, modifications, or improvements to the equipment referenced herein or to the document itself at any time. This document is intended for trained personnel familiar with the GE products referenced herein.

This document is approved for public disclosure.

GE may have patents or pending patent applications covering subject matter in this document. The furnishing of this document does not provide any license whatsoever to any of these patents.

GE provides the following document and the information included therein as is and without warranty of any kind, expressed or implied, including but not limited to any implied statutory warranty of merchantability or fitness for particular purpose.

For further assistance or technical information, contact the nearest GE Sales or Service Office, or an authorized GE Sales

Representative. Information contained in this document is indicative. No representation or warranty is given or should be relied on. Information provided is subject to change without notice.

© 2023 GE Vernova and/or its affiliates. All rights reserved.

GEA35311 (08/2023)