

GE Power

# Heavy-Duty Gas Turbine Operating and Maintenance Considerations

GER-3620P (01/21)

**Diane Beagle**

**Brian Moran**

**Michael McDufford**

**Mardy Merine**

GE Power  
Atlanta, GA





# Contents

<b>Introduction</b>	<b>1</b>
<b>Maintenance Planning</b>	<b>1</b>
<b>Digital Solutions for Asset Management</b>	<b>3</b>
<b>Gas Turbine Configuration Maintenance Features</b>	<b>3</b>
Borescope Inspections	4
<b>Major Factors Influencing Maintenance and Equipment Life</b>	<b>5</b>
Starts and Hours Criteria	5
Service Factors	6
Fuel	7
Firing Temperatures	9
Steam/Water Injection	9
Cyclic Effects and Fast Starts	10
Hot Gas Path Parts	11
Rotor Parts	13
Combustion Parts	16
Casing Parts	17
Exhaust Diffuser Parts	18
Off-Frequency Operation	18
Compressor Condition and Performance	19
Lube Oil Cleanliness	20
Moisture Intake	20
<b>Maintenance Inspections</b>	<b>21</b>
Standby Inspections	21
Running Inspections	21
Rapid Cool-Down	23
Combustion Inspection	23
Hot Gas Path Inspection	25
Major Inspection	27
<b>Parts Planning</b>	<b>29</b>
<b>Inspection Intervals</b>	<b>30</b>
Borescope Inspection Interval	30
ABC Inspections For Annular/Silo Fleet	30
Combustion Inspection Interval	34
Hot Gas Path Inspection Interval	36
GE Annular/Silo Fleet Inspection Intervals	37
Rotor Inspection Interval	37
GE Annular/Silo Fleet Welded Rotor Inspection	38

**Personnel Planning**..... 39

**Conclusion**..... 39

**References**..... 40

**Appendix** ..... 41

    A.1) Example 1 – Hot Gas Path Maintenance Interval Calculation .....41

    A.2) Example 2 – Hot Gas Path Factored Starts Calculation.....42

    A.3) Example 3 – Load Step Maintenance Factor Calculation.....42

    B) Examples – Combustion Maintenance Interval Calculations  
    (Reference **Figures 39 and 40**).....43

    C) Definitions .....44

    D) Estimated Repair and Replacement Intervals (Natural Gas Only).....45

    E) Borescope Inspection Ports .....49

    F) Turning Gear/Ratchet Running Guidelines .....53

    G) B/E-, F-, and H-class Gas Turbine Naming .....54

**Revision History** ..... 55

**List of Figures**..... 57

**Acknowledgments** ..... 58

# Heavy-Duty Gas Turbine Operating and Maintenance Considerations

## Introduction

Maintenance costs and machine availability are two of the most important concerns to a heavy-duty gas turbine equipment owner. Therefore, a well thought out maintenance program that reduces the owner's costs while increasing equipment availability should be instituted. For this maintenance program to be effective, owners should develop a general understanding of the relationship between the operating plans and priorities for the plant, the skill level of operating and maintenance personnel, and all equipment manufacturer's recommendations regarding the number and types of inspections, spare parts planning, and other major factors affecting component life and proper operation of the equipment.

In this document, operating and maintenance practices for heavy-duty gas turbines will be reviewed, with emphasis placed on types of inspections plus operating factors that influence maintenance schedules.

### Note:

- The operation and maintenance practices outlined in this document are based on full utilization of GE-approved parts, repairs, and services. Contact GE for support and solutions when operational practices are not aligned with GER-3620 recommendations.
- The operating and maintenance discussions presented are generally applicable to all GE heavy-duty gas turbines; i.e., Frames 3, 5, 6, 7, and 9. *Appendix G* provides a list of common B/E-, F-, and H-class heavy-duty gas turbines with current and former naming conventions. For purposes of illustration, the GE GT-7E.03 was chosen for most components except exhaust systems, which are illustrated using different gas turbine models as indicated. Also, the operating and maintenance discussions presented for all B/E-class units are generally applicable to Frame 3 and Frame 5 units unless otherwise indicated. Consult the GE Operation and Maintenance (O&M) Manual for specific questions on a given machine, or contact the local GE service representative.
- GE merged with Alstom in 2015. This revision of GER-3620 includes operating and maintenance considerations applicable to Alstom technology type heavy duty gas turbines (later named GE Annular/Silo Fleet) where explicitly stated. The naming for the GE Annular/Silo Fleet is related to the type of combustion

system installed and further described in chapter "Combustion Parts"/Appendix G. Unit specific inspection guidelines (IGLs) should be consulted for detailed operating and maintenance considerations, including maintenance intervals and recommended outage scope.

## Maintenance Planning

Advanced planning for maintenance is necessary for utility, industrial, independent power, and cogeneration plant operators in order to maintain reliability and availability. The correct implementation of planned maintenance and inspection provides direct benefits in the avoidance of forced outages, unscheduled repairs, and downtime. The primary factors that affect the maintenance planning process are shown in *Figure 1*. The owners' operating mode and practices will determine how each factor is weighted. Gas turbine parts requiring the most careful attention are those associated with the combustion process, together with those exposed to the hot gases discharged from the combustion system. These are called the combustion section and hot gas path parts, and they include combustion liners, end caps, fuel nozzle assemblies, crossfire tubes, transition pieces, turbine nozzles, turbine stationary shrouds, and turbine buckets.

Additional, longer-term areas for consideration and planning are the lives of the compressor rotor, turbine rotor, casings, and exhaust diffuser. The basic configuration and recommended maintenance of GE heavy-duty gas turbines are oriented toward:

- Maximum periods of operation between inspections and overhauls
- In-place, on-site inspection and maintenance
- Use of local trade skills to disassemble, inspect, and re-assemble gas turbine components

In addition to maintenance of the basic gas turbine, other station auxiliaries require periodic servicing including the control devices, fuel-metering equipment, gas turbine auxiliaries, and load package. The primary maintenance effort involves five basic systems: controls and accessories, combustion, turbine, generator, and balance-of-plant. Controls and accessories are typically serviced in outages of short duration, whereas the other four systems are maintained through less frequent outages of longer duration. This document is focused on

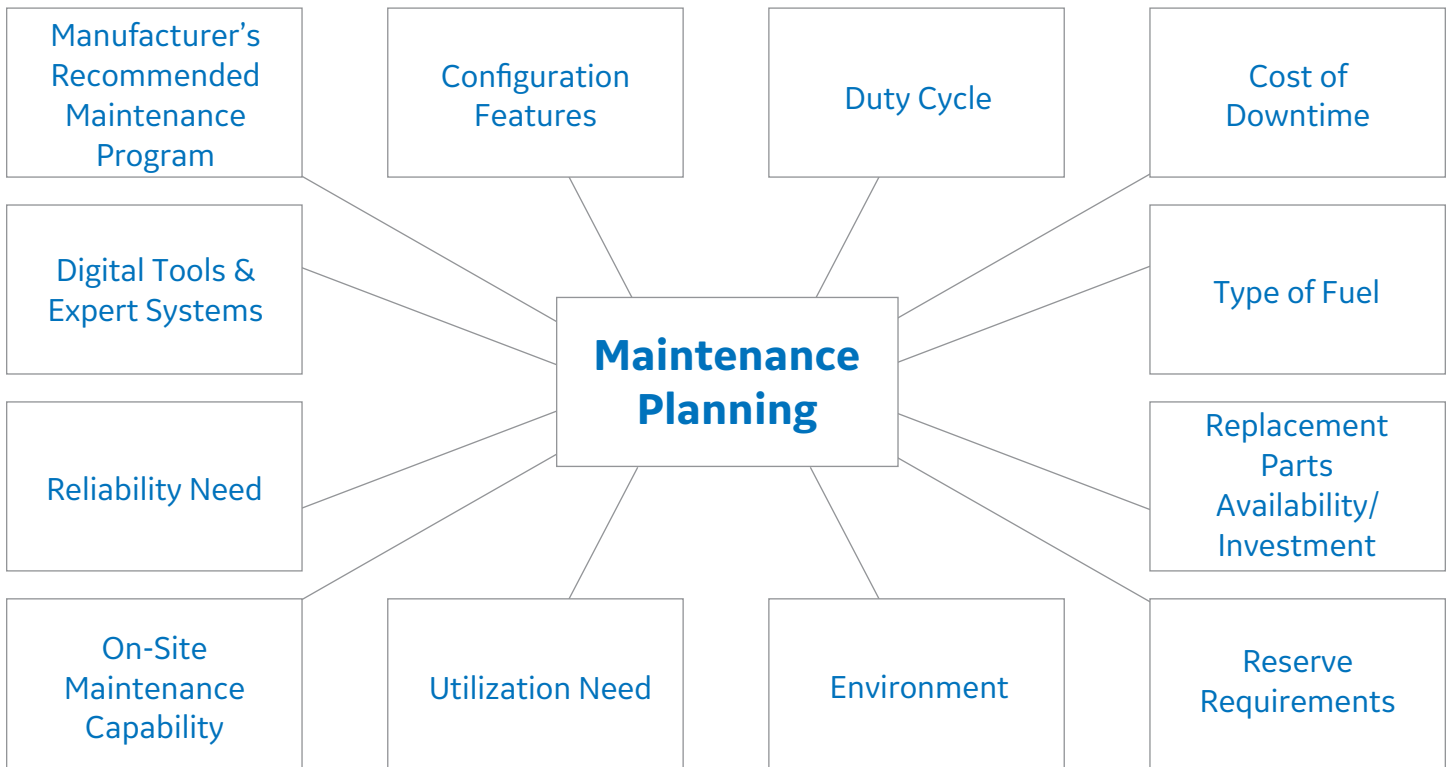

**Figure 1.** Key factors affecting maintenance planning

maintenance planning for the basic gas turbine, which includes the combustion and turbine systems. The other systems, while outside the scope of this document, also need to be considered for successful plant maintenance.

The inspection and repair requirements, outlined in the O&M Manual provided to each owner, lend themselves to establishing a pattern of inspections. These inspection patterns will vary from site to site, because factors such as air and fuel quality are used to develop an inspection and maintenance program. In addition, supplementary information is provided through a system of Technical Information Letters (TILs) associated with specific gas turbines after shipment. This updated information, in addition to the O&M manual, aims to assure optimum installation, operation, and maintenance of the turbine. (See *Figure 2.*) Many of the TILs contain advisory technical recommendations to help resolve issues and improve the operation, maintenance, safety, reliability, or availability of the turbine. The recommendations contained in TILs should be reviewed and factored into the overall maintenance planning program.

- **O&M Manual**
  - Turbine-specific manual provided to customer
  - Includes outline of recommended Inspection and Repair requirements
  - Helps customers to establish a pattern of systematic inspections for their site
- **Technical Information Letters (TILs)\***
  - Issued after shipment of turbine
  - Provides O&M updates related to turbine installation, maintenance, and operation
  - Provides advisory technical recommendations to help resolve potential issues

\* Specific smaller frame turbines are issued service letters known as Customer Information Notices (NICs) instead of TILs

**Figure 2.** Key technical reference documents to include in maintenance planning

## Digital Solutions for Asset Management

Operational and business conditions are continually evolving as the power industry is undergoing a rapid transformation. Dynamic conditions require power generation and utility companies to refine how they monitor and maintain operating assets. Businesses that embrace digital solutions have best managed these dynamic shifts in the industry. GE provides a suite of digital tools that is built on years of power production domain expertise. These tools enable strategic plant operation by providing insights related to equipment operation, improved outage planning, and more continuous operation in line with industry demand. GE Power's Asset Performance Management (APM), M&D Center coverage, and Asset Life Odometers, can improve reliability, availability and improve maintenance across not only the gas turbine, but the entire plant.

- **Asset Performance Management (APM)**

GE Power's Asset Performance Management solution is a dynamic suite of tools, created to provide customers with real time access to data and predictive analytics in a collaborative environment focused on enhancing operation and maintenance decisions. APM not only gives insight into asset operation but also provides the capability to shift to a predictive maintenance operating model. Utilizing GE's expertise as one of the leading OEMs in the industry, physics based and fleet reliability models can more accurately predict the effect of operation and events, on parts and assets across the plant. Our advanced models, linked to failure modes, enable customers to extend useful life of parts, improve outage workloads and enhance outage planning cycles. With one of the widest failure mode coverages in the industry, APM helps asset-centric organizations drive safer and more reliable operations while facilitating improved performance at a lower, more sustainable, cost.

- **Remote Monitoring and Diagnostic (M&D) Center**

The GE Remote M&D Center provides customers direct access to GE engineers and power production experts for real-time collaboration on operation and maintenance decisions. Utilizing the latest Digital tools, subject matter experts in the M&D center continuously monitor connected assets, evaluate alarm indications, and take action to help ensure accurate diagnoses and rapid remediation. First established over 20 years ago, GE's

M&D center is connected to more than 5000 power production assets, giving GE one of the richest data sets of experience from across the world, which combines with our unique domain knowledge to provide excellent analytics, and proven results reducing unplanned downtime.

- **Outage Workscope**

GE Power's Outage Excellence process, a milestone-driven outage planning cycle, improves asset specific outage workscope through digital predictions and inspections. This methodology enables GE and customers, to plan and execute real-time condition based maintenance and provision emergent work, on time and to budget. Digital inspections are utilized to analyze asset conditions and evaluate technical risks, thereby identifying the correct outage scope to reduce unplanned downtime with no impact to performance.

## Gas Turbine Configuration Maintenance Features

The GE heavy-duty gas turbine is constructed to withstand severe duty and to be maintained on-site, with off-site repair required only on certain combustion components, hot gas path parts, and rotor assemblies needing specialized shop service. The following features are configured into GE heavy-duty gas turbines to facilitate on-site maintenance:

- All casings, shells and frames are split on machine horizontal centerline. Upper halves may be lifted individually for access to internal parts.
- With upper-half compressor casings removed, all stationary vanes can be slid circumferentially out of the casings for inspection or replacement without rotor removal. HA gas turbines also require the removal of inner casings for hot gas path maintenance.
- With the upper-half of the turbine shell lifted, each half of the first stage nozzle assembly can be removed for inspection, repair, or replacement without rotor removal. On some units, upper-half, later-stage nozzle assemblies are lifted with the turbine shell, also allowing inspection and/or removal of the turbine buckets. HA gas turbines require removal of the inner turbine shell for access to and maintenance of the hot gas path hardware. Special tooling is required to remove

the inner turbine shell. The GE Annular/Silo Fleet requires removal of the upper-half and inner shell as well as the rotor to access all nozzles for maintenance.

- All turbine buckets are moment-weighted and computer charted in sets for rotor spool assembly so that they may be replaced without the need to remove or rebalance the rotor assembly.
- All bearing housings and liners are split on the horizontal centerline so that they may be inspected and replaced when necessary. The lower half of the bearing liner can be removed without removing the rotor.
- All seals and shaft packings are separate from the main bearing housings and casing structures and may be readily removed and replaced.
- On most configurations, combustion components can be removed for inspection, maintenance, or replacement without lifting any casings. All major accessories, including filters and coolers, are separate assemblies that are readily accessible for inspection or maintenance. They may also be individually replaced as necessary.
- Casings can be inspected during any outage or any shutdown when the unit enclosure is cool enough for safe entry. The exterior of the inlet, compressor case, compressor discharge case, turbine case, and exhaust frame can be inspected during any outage or period when the enclosure is accessible. The interior surfaces of these cases can be inspected to various degrees depending on the type of outage performed. All interior surfaces can be inspected during a major outage.
- Exhaust diffusers can be inspected during any outage by entering the diffuser through the stack or Heat Recovery Steam Generator (HRSG) access doors. The flow path surfaces, flex seals, and other flow path hardware can be visually inspected with or without the use of a borescope. Diffusers can be weld-repaired without the need to remove the exhaust frame upper half.
- Inlets can be inspected during any outage or shutdown.

As an alternative to on-site maintenance, in some cases plant availability can be improved by applying gas turbine modular replacements. This is accomplished by exchanging engine modules or even the complete gas turbine with new or refurbished units.

The removed modules/engines can then be sent to an alternate location for maintenance.

Provisions have been built into GE heavy-duty gas turbines to facilitate several special inspection procedures. These special procedures provide for the visual inspection and clearance measurement of some of the critical internal components without removal of the casings. These procedures include gas path borescope inspection (BI), radial clearance measurements, and turbine nozzle axial clearance measurements.

A GE gas turbine is a fully integrated configuration consisting of stationary and rotating mechanical, fluid, thermal, and electrical systems. The turbine's performance, as well as the performance of each component within the turbine, is dependent upon the operating interrelationship between internal components and the total operating systems. GE's engineering process evaluates how new configurations, configuration changes, and repairs affect components and systems. This configuration, evaluation, testing, and approval helps assure the proper balance and interaction between all components and systems for safe, reliable, and economical operation.

The introduction of new, repaired, or modified parts must be evaluated in order to avoid negative effects on the operation and reliability of the entire system. The use of non-GE approved parts, repairs, and maintenance practices may represent a significant risk. Pursuant to the governing terms and conditions, warranties and performance guarantees are predicated upon proper storage, installation, operation, and maintenance, conforming to GE approved operating instruction manuals and repair/modification procedures.

### **Borescope Inspections**

An effective borescope inspection program monitors the condition of internal components without casing removal. Borescope inspections should be scheduled with consideration given to the operation and environment of the gas turbine and information from the O&M Manual and TILs.

GE heavy-duty gas turbine designs incorporate provisions in both compressor and turbine casings for borescope inspection of intermediate compressor rotor stages, first, second and third-stage turbine buckets, and turbine nozzle partitions. These provisions are radially aligned holes through the compressor



casings, turbine shell, and internal stationary turbine shrouds that allow the penetration of an optical borescope into the compressor or turbine flow path area. Borescope inspection access locations for the various frame sizes can be found in *Appendix E*.

*Figure 3* provides a recommended interval for a planned borescope inspection program following initial baseline inspections. It should be recognized that these borescope inspection intervals are based on average unit operating modes. Adjustment of these borescope intervals may be made based on operating experience, mode of operation, fuels used, employment of online M&D analytics, and the results of previous borescope inspections. GE should be consulted before any change to the borescope frequency is made.

In general, an annual or semiannual borescope inspection uses all the available access points to verify the condition of the internal hardware. This should include, but is not limited to, signs of excessive gas path fouling, symptoms of surface degradation (such as erosion, corrosion, or spalling), displaced components, deformation or object damage, material loss, nicks, dents, cracking, indications of contact or rubbing, or other anomalous conditions.

<b>Borescope</b>	Gas and Distillate Fuel Oil	At combustion inspection or annually, whichever occurs first
	Heavy Fuel Oil	At combustion inspection or semiannually, whichever occurs first

**Figure 3.** Borescope inspection planning

During BIs and similar inspections, the condition of the upstream components should be verified, including all systems from the filter house to the compressor inlet.

The application of a borescope monitoring program will assist with the scheduling of outages and preplanning of parts requirements, resulting in outage preparedness, lower maintenance costs, and higher availability and reliability of the gas turbine.

## Major Factors Influencing Maintenance and Equipment Life

There are many factors that can influence equipment life, and these must be understood and accounted for in the owner's maintenance planning. Starting cycle (hours per start), power setting, fuel, level of steam or water injection, and site environmental conditions are some of the key factors in determining maintenance interval requirements, as these factors directly influence the life of replaceable gas turbine parts.

Non-consumable components and systems, such as the compressor airfoils, may be affected by site environmental conditions as well as plant and accessory system effects. Other factors affecting maintenance planning are shown in *Figure 1*. Operators should consider these external factors to prevent the degradation and shortened life of non-consumable components. GE provides supplementary documentation to assist in this regard.

In the GE approach to maintenance planning, a natural gas fuel unit that operates at base load with no water or steam injection is established as the baseline condition, which sets the maximum recommended maintenance intervals. For operation that differs from the baseline, maintenance factors (MF) are established to quantify the effect on component lives and provide the increased frequency of maintenance required. For example, a maintenance factor of two would indicate a maintenance interval that is half of the baseline interval.

### Starts and Hours Criteria

Gas turbines wear differently in continuous duty application and cyclic duty application, as shown in *Figure 5*. Thermal mechanical fatigue is the dominant life limiter for peaking machines, while creep, oxidation, and corrosion are the dominant life limiters for continuous duty machines. GE bases most gas turbine maintenance requirements on independent counts of starts and hours. Whichever criteria limit is first reached determines the maintenance interval. A graphical display of the GE approach is shown in *Figure 8*. In this figure, the inspection interval recommendation is defined by the rectangle established by the starts and hours criteria. These recommendations for

inspection fall within the parts' life expectations and are selected such that components acceptable for continued use at the inspection point will have low risk of failure during the subsequent operating interval.

• Continuous Duty Application	• Cyclic Duty Application
- Rupture	- Thermal Mechanical Fatigue
- Creep Deflection	- High-Cycle Fatigue
- Corrosion	- Rubs/Wear
- Oxidation	- Foreign Object Damage
- Erosion	
- High-Cycle Fatigue	
- Rubs/Wear	
- Foreign Object Damage	

Figure 4. Causes of wear – hot gas path components

The interactions of continuous duty and cyclic duty applications can have a second order effect on the lifetime of components. As a result, an alternative to the aforementioned approach, converts each start cycle and operating hour to an equivalent number of operating hours (EOH) with inspection intervals based on the equivalent hours count. The EOH counting may be done through

either a linear or elliptical formula. A third variant for determining maintenance intervals is a combination of the starts, operating hours and EOH concept.

These various EOH methods are illustrated in Figure 6.

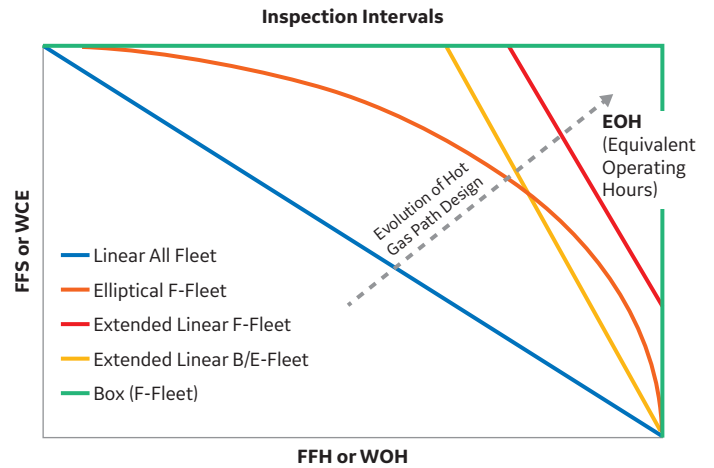

Figure 6. Hot gas path maintenance interval comparisons. GE method vs. EOH method. FFS = Factored Fired Starts, FFH = Factored Fired Hours, WCE = Weighted Cyclic Events, WOH = Weighted Operating Hours.

### Service Factors

The effect of fired starts and fired hours on component lifetime are not the only wear mechanisms which must be considered. As

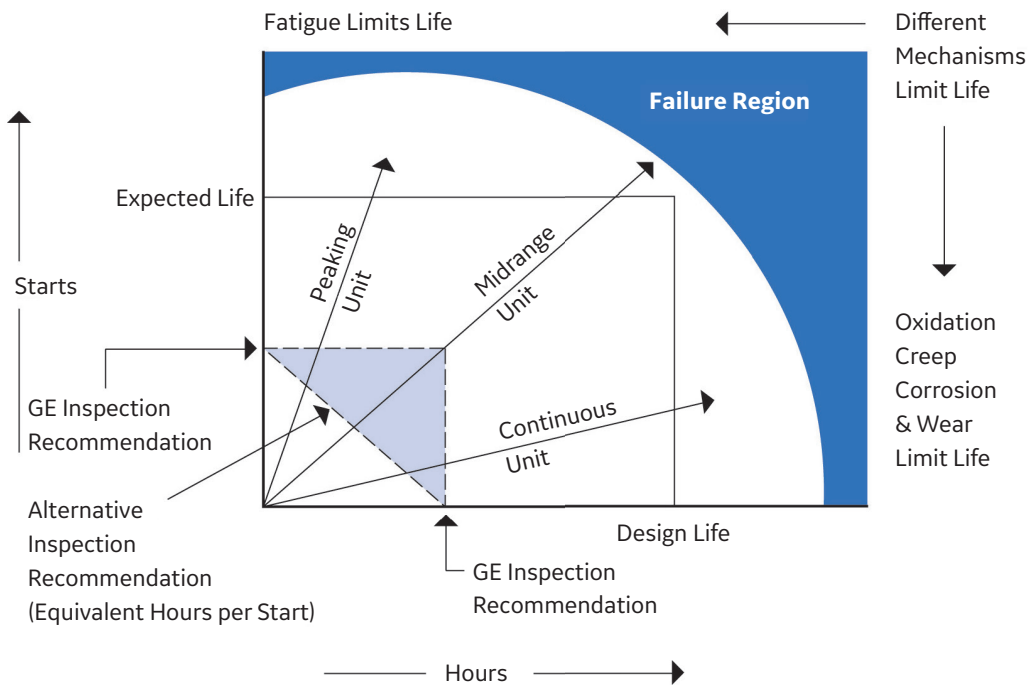

Figure 5. GE bases gas turbine maintenance requirements on independent counts of starts and hours

shown in *Figure 7*, influences such as fuel type and quality, firing temperature setting, and the amount of steam or water injection are considered with regard to the hours-based criteria. Startup rate and the number of trips are considered with regard to the starts-based criteria. In both cases, these influences may reduce the maintenance intervals.

Typical baseline inspection intervals (6B.03/7E.03):

Hot gas path inspection	24,000 hrs or 1200 starts
Major inspection	48,000 hrs or 2400 starts

Criterion is hours or starts (whichever occurs first)

Factors affecting maintenance:

**Hours-Based Factors**

- Fuel type
- Peak load
- Diluent (water or steam injection)

**Starts-Based Factors**

- Start type (conventional or peaking-fast)
- Start load (max. load achieved during start cycle, e.g. part, base, or peak load)
- Shutdown type (normal cooldown, rapid cooldown, or trip)

**Figure 7.** Maintenance factors

When these service or maintenance factors are involved in a unit’s operating profile, the hot gas path maintenance “rectangle” that describes the specific maintenance criteria for this operation is reduced from the ideal case, as illustrated in *Figure 8*. The following discussion will take a closer look at the key operating factors and how they can affect maintenance intervals as well as parts refurbishment/replacement intervals.

**Maintenance Factors Reduce Maintenance Interval**

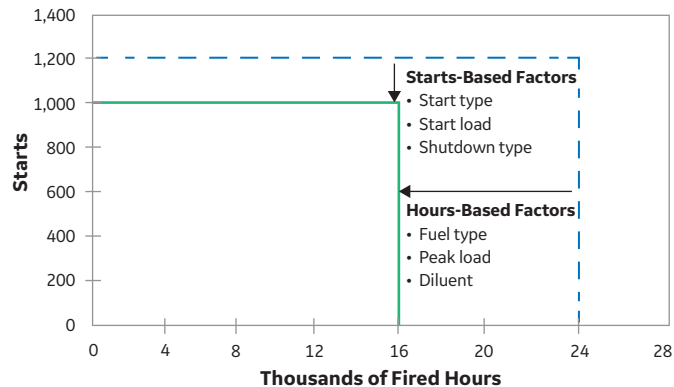

**Figure 8.** GE maintenance intervals

**Fuel**

Fuels burned in gas turbines range from clean natural gas to residual oils and affect maintenance, as illustrated in *Figure 9*. Although *Figure 9* provides the basic relationship between fuel severity factor and hydrogen content of the fuel, there are other fuel constituents that should be considered. Selection of fuel severity factor typically requires a comprehensive understanding of fuel constituents and how they affect system maintenance. The selected fuel severity factor should also be adjusted based on inspection results and operating experience.

Heavier hydrocarbon fuels have a maintenance factor ranging from three to four for residual fuels and two to three for crude oil fuels. This maintenance factor is adjusted based on the water-to-fuel ratio in cases when water injection for NO<sub>x</sub> abatement is used. These fuels generally release a higher amount of radiant thermal energy, which results in a subsequent reduction in combustion hardware life, and frequently contain corrosive elements such as sodium, potassium, vanadium, and lead that can cause accelerated hot corrosion of turbine nozzles and buckets. In addition, some elements in these fuels can cause deposits either directly or through compounds formed with inhibitors that are used to prevent corrosion. These deposits affect performance and can require more frequent maintenance.

Distillates, as refined, do not generally contain high levels of these corrosive elements, but harmful contaminants can be present in these fuels when delivered to the site. Two common ways of contaminating number two distillate fuel oil are: salt-water ballast mixing with the cargo during sea transport, and contamination of the distillate fuel when transported to site in tankers, tank trucks, or pipelines that were previously used to transport contaminated fuel, chemicals, or leaded gasoline. GE’s experience with distillate fuels indicates that the hot gas path maintenance factor can range from as low as one (equivalent to natural gas) to as high as three. Unless operating experience suggests otherwise, it is recommended that a hot gas path maintenance factor of 1.5 be used for operation on distillate oil. Note also that contaminants in liquid fuels can affect the life of gas turbine auxiliary components such as fuel pumps and flow dividers.

Not shown in *Figure 9* are alternative fuels such as industrial process gas, syngas, and bio-fuel. A wide variety of alternative fuels exist, each with their own considerations for combustion in

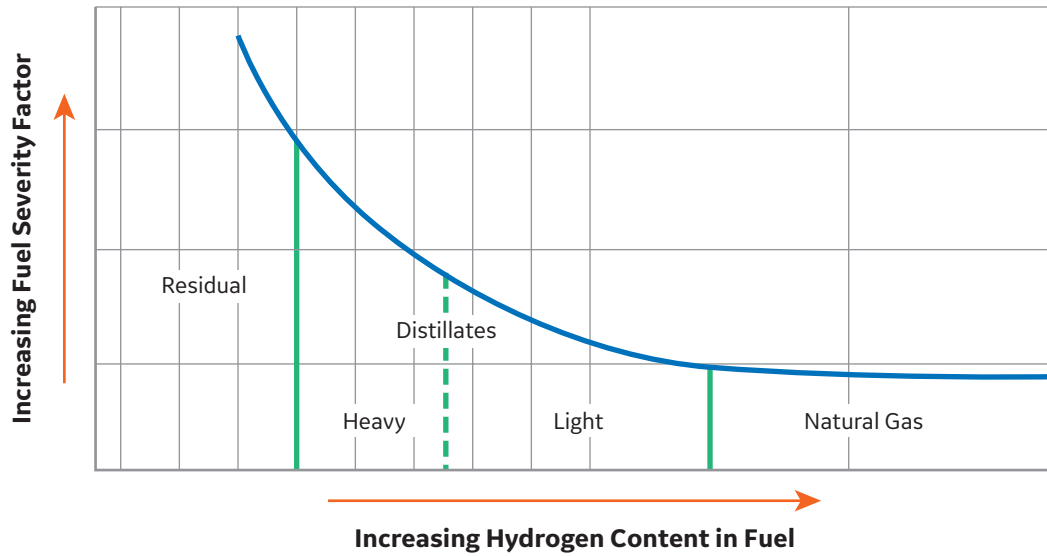

**Figure 9.** Estimated effect of fuel type on maintenance

a gas turbine. Although some alternative fuels can have a neutral effect on gas turbine maintenance, many alternative fuels require unit-specific intervals and fuel severity factors to account for their fuel constituents or water/steam injection requirements.

As shown in *Figure 9*, natural gas fuel that meets GE specification is considered the baseline, optimum fuel with regard to turbine maintenance. Proper adherence to GE fuel specifications in GEI-41040 and GEI-41047 is required to allow proper combustion system operation and to maintain applicable warranties. Liquid hydrocarbon carryover can expose the hot gas path hardware to severe overtemperature conditions that can result in significant reductions in hot gas path parts lives or repair intervals. Liquid hydrocarbon carryover is also responsible for upstream displacement of flame in combustion chambers, which can lead to severe combustion hardware damage. Owners can control this potential issue by using effective gas scrubber systems and by superheating the gaseous fuel prior to use to approximately 50°F (28°C) above the hydrocarbon dew point temperature at the turbine gas control valve connection. For exact superheat requirement calculations, please review GEI 41040. Integral to the system, coalescing filters installed upstream of the performance gas heaters is a best practice and ensures the most efficient removal of liquids and vapor phase constituents.

Undetected and untreated, a single shipment of contaminated fuel can cause substantial damage to the gas turbine hot gas

path components. Potentially high maintenance costs and loss of availability can be reduced or eliminated by:

- Placing a proper fuel specification on the fuel supplier. For liquid fuels, each shipment should include a report that identifies specific gravity, flash point, viscosity, sulfur content, pour point and ash content of the fuel.
- Providing a regular fuel quality sampling and analysis program. As part of this program, continuous monitoring of water content in fuel oil is recommended, as is fuel analysis that, at a minimum, monitors vanadium, lead, sodium, potassium, calcium, and magnesium.
- Providing proper maintenance of the fuel treatment system when burning heavier fuel oils.
- Providing cleanup equipment for distillate fuels when there is a potential for contamination.

In addition to their presence in the fuel, contaminants can also enter the turbine via inlet air, steam/water injection, and carryover from evaporative coolers. In some cases, these sources of contaminants have been found to cause hot gas path degradation equal to that seen with fuel-related contaminants. GE specifications define limits for maximum concentrations of contaminants for fuel, air, and steam/water.

In addition to fuel quality, fuel system operation is also a factor in equipment maintenance. Liquid fuel should not remain unpurged

or in contact with hot combustion components after shutdown and should not be allowed to stagnate in the fuel system when strictly gas fuel is run for an extended time. To reduce varnish and coke accumulation, dual fuel units (gas and liquid capable) should be shutdown running gas fuel whenever possible. Likewise, during extended operation on gas, regular transfers from gas to liquid are recommended to exercise the system components and reduce coking.

Contamination and build-up may prevent the system from removing fuel oil and other liquids from the combustion, compressor discharge, turbine, and exhaust sections when the unit is shut down or during startup. Liquid fuel oil trapped in the system piping also creates a safety risk. Correct functioning of the false start drain system (FSDS) should be ensured through proper maintenance and inspection per GE procedures.

### Firing Temperatures

Peak load is defined as operation above base load and is achieved by increasing turbine operating temperatures. Significant operation at peak load will require more frequent maintenance and replacement of hot gas path and combustion components. Figure 10 defines the parts life effect corresponding to increases in firing temperature. It should be noted that this is not a linear relationship, and this equation should not be used for decreases in firing temperature.

$$\text{B/E-class: } A_p = e^{(0.018 \cdot \Delta T_f)}$$

$$\text{F-class: } A_p = e^{(0.023 \cdot \Delta T_f)}$$

$A_p$  = Peak fire severity factor

$\Delta T_f$  = Peak firing temperature adder (in °F)

Figure 10. Peak fire severity factors - natural gas and light distillates

It is important to recognize that a reduction in load does not always mean a reduction in firing temperature. For example, in heat recovery applications, where steam generation drives overall plant efficiency, load is first reduced by closing variable inlet guide vanes to reduce inlet airflow while maintaining maximum exhaust temperature. For these combined cycle applications, firing temperature does not decrease until load is

reduced below approximately 80% of rated output. Conversely, a non-DLN turbine running in simple cycle mode maintains fully open inlet guide vanes during a load reduction to 80% and will experience over a 200°F/111°C reduction in firing temperature at this output level. The hot gas path and combustion part lives change for different modes of operation. This turbine control effect is illustrated in Figure 11. Turbines with DLN combustion systems use inlet guide vane turndown as well as inlet bleed heat to extend operation of low NO<sub>x</sub> premix operation to part load conditions.

Firing temperature effects on hot gas path and combustion maintenance as described above, relate to clean burning fuels such as natural gas and light distillates. Higher operating temperatures affect the creep capability of hot gas path components which is the primary life limiting mechanism. The life capability of combustion components can also be affected.

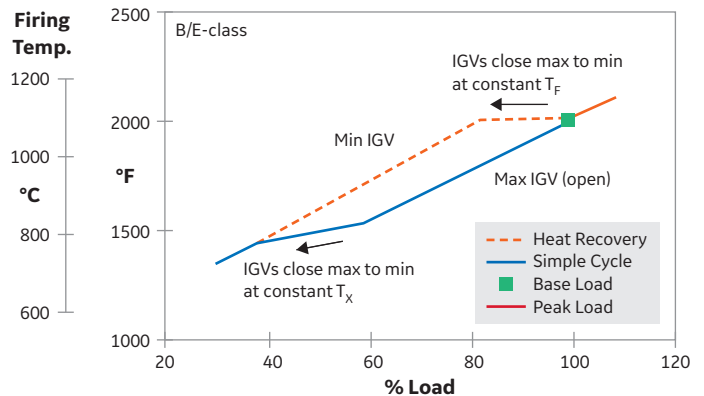

Figure 11. Firing temperature and load relationship – heat recovery vs. simple cycle operation

### Steam/Water Injection

Water or steam injection for emissions control or power augmentation can affect part life and maintenance intervals even when the water or steam meets GE specifications. This relates to the effect of the added water on the hot gas transport properties. Higher gas conductivity, in particular, increases the heat transfer to the buckets and nozzles and can lead to higher metal temperature and reduced part life.

Part life reduction from steam or water injection is directly affected by the way the turbine is controlled. The control system on most base load applications reduces firing temperature as water or steam is injected. This is known as dry control curve

operation, which counters the effect of the higher heat transfer on the gas side and results in no net effect on bucket life. This is the standard configuration for all gas turbines, both with and without water or steam injection. On some installations, however, the control system is configured to keep firing temperature constant with water or steam injection. This is known as wet control curve operation, which results in additional unit output but decreases parts life as previously described. Units controlled in this way are generally in peaking applications where annual operating hours are low or where operators have determined that reduced parts lives are justified by the power advantage. *Figure 12* illustrates the wet and dry control curve and the performance differences that result from these two different modes of control.

### Steam Injection for 25 pmm NO<sub>x</sub>

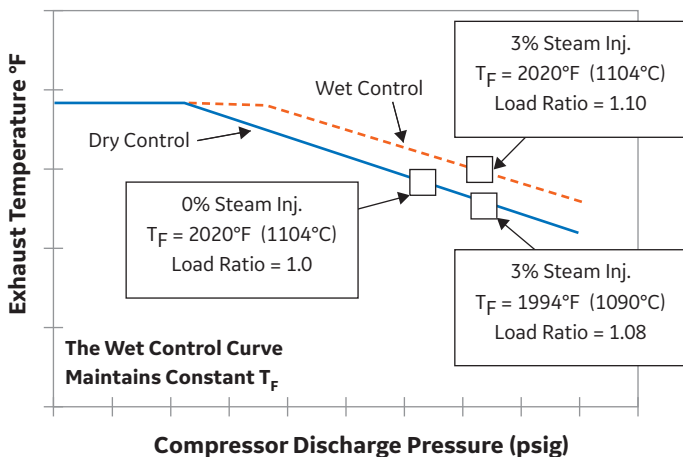

**Figure 12.** Exhaust temperature control curve – dry vs. wet control 7E.03

An additional factor associated with water or steam injection relates to the higher aerodynamic loading on the turbine components that results from the injected flow increasing the cycle pressure ratio. This additional loading can increase the downstream deflection rate of the second- and third-stage nozzles, which would reduce the repair interval for these components. However, the introduction of high creep strength stage two and three nozzle (S2N/S3N) alloys, such as GTD-222™\* and GTD-241™\*, has reduced this factor in comparison to previously applied materials such as FSX-414\* and N-155\*.

Water injection for NO<sub>x</sub> abatement should be performed according to the control schedule implemented in the controls system. Forcing operation of the water injection system at high loads can lead to combustion and HGP hardware damage due to thermal shock.

### Cyclic Effects and Fast Starts

In the previous discussion, operating factors that affect the hours-based maintenance criteria were described. For the starts-based maintenance criteria, operating factors associated with the cyclic effects induced during startup, operation, and shutdown of the turbine must be considered. Operating conditions other than the standard startup and shutdown sequence can potentially reduce the cyclic life of the gas turbine components and may require more frequent maintenance including part refurbishment and/or replacement.

Fast starts are common deviations from the standard startup sequence. GE has introduced a number of different fast start systems, each applicable to particular gas turbine models. Fast starts may include any combination of Anticipated Start Purge, fast acceleration (light-off to FSNL), and fast loading. Some fast start methods do not affect inspection interval maintenance factors. Fast starts that do affect maintenance factors are referred to as peaking-fast starts or simply peaking starts.

The effect of peaking-fast starts on the maintenance interval depends on the gas turbine model, the unit configuration, and the particular start characteristics. For example, simple cycle 7F.03 units with fast start capability can perform a peaking start in which the unit is brought from ignition to full load in less than 15 minutes. Conversely, simple cycle 6B and other smaller frame units can perform conventional starts that are less than 15 minutes without affecting any maintenance factors. For units that have peaking-fast start capability, *Figure 13* shows conservative peaking-start factors that may apply.

Because the peaking-fast start factors can vary by unit and by system, the baseline factors may not apply to all units. For example, the latest 7F.03 peaking-fast start system has the start factors shown in *Figure 14*. For comparison, the 7F.03 nominal fast start that does not affect maintenance is also listed. Consult applicable unit-specific documentation or your GE service representative to verify the hours/starts factors that apply.

\* Trademark of General Electric Company

### Starts-Based Combustion Inspection

$A_s = 4.0$  for B/E-class

$A_s = 2.0$  for F-class

### Starts-Based Hot Gas Path Inspection

$P_s = 3.5$  for B/E-class

$P_s = 1.2$  for F-class

### Starts-Based Rotor Inspection

$F_s = 2.0$  for F-class\*

\* See Figure 21 for details

Refer to unit specific documentation for HA-class

Figure 13. Peaking-fast start factors

### 7F.03 Starts-Based Combustion Inspection

$A_s = 1.0$  for 7F nominal fast start

$A_s = 1.0$  for 7F peaking-fast start

### 7F.03 Starts-Based Hot Gas Path Inspection

$P_s =$  Not applicable for 7F nominal fast start (counted as normal starts)

$P_s = 0.5$  for 7F peaking-fast start

### 7F.03 Starts-Based Rotor Inspection

$F_s = 1.0$  for 7F nominal fast start

$F_s = 2.0$  for 7F peaking-fast start\*

\* See Figure 21 for details

Figure 14. 7F.03 fast start factors

## Hot Gas Path Parts

Figure 15 illustrates the firing temperature changes occurring over a normal startup and shutdown cycle. Light-off, acceleration, loading, unloading, and shutdown all produce gas and metal temperature changes. For rapid changes in gas temperature, the edges of the bucket or nozzle respond more quickly than the thicker bulk section, as pictured in Figure 16. These gradients, in turn, produce thermal stresses that, when cycled, can eventually lead to cracking.

Figure 17 describes the temperature/strain history of a representative bucket stage 1 bucket during a normal startup and shutdown cycle. Light-off and acceleration produce transient compressive strains in the bucket as the fast responding leading

edge heats up more quickly than the thicker bulk section of the airfoil. At full load conditions, the bucket reaches its maximum metal temperature and a compressive strain is produced from the normal steady state temperature gradients that exist in the cooled part. At shutdown, the conditions reverse and the faster responding edges cool more quickly than the bulk section, which results in a tensile strain at the leading edge.

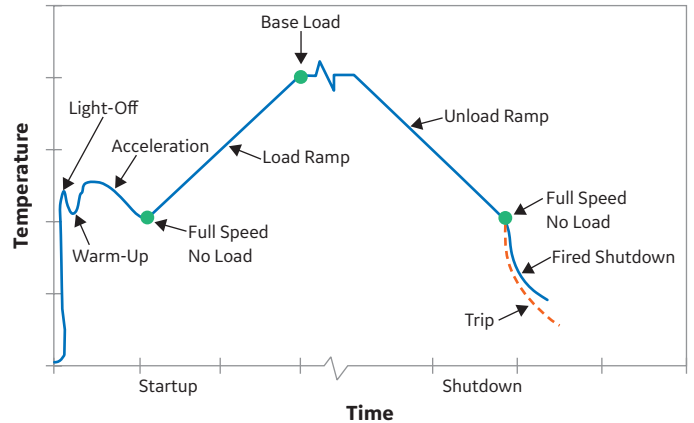

Figure 15. Turbine start/stop cycle - firing temperature changes

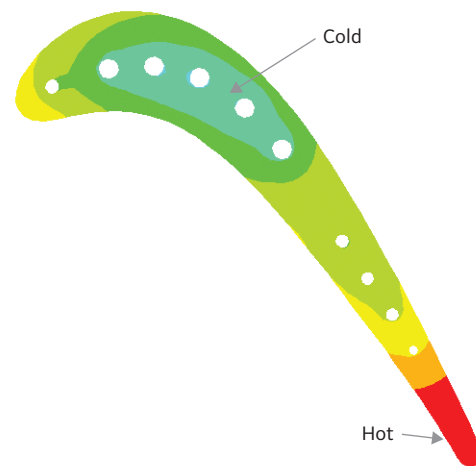

Figure 16. Second stage bucket transient temperature distribution

Thermal mechanical fatigue testing has found that the number of cycles that a part can withstand before cracking occurs is strongly influenced by the total strain range and the maximum metal temperature. Any operating condition that significantly increases the strain range and/or the maximum metal temperature over the normal cycle conditions will reduce the fatigue life and increase the starts-based maintenance factor. For example,



**Key Parameters**

- Max Strain Range
- Max Metal Temperature

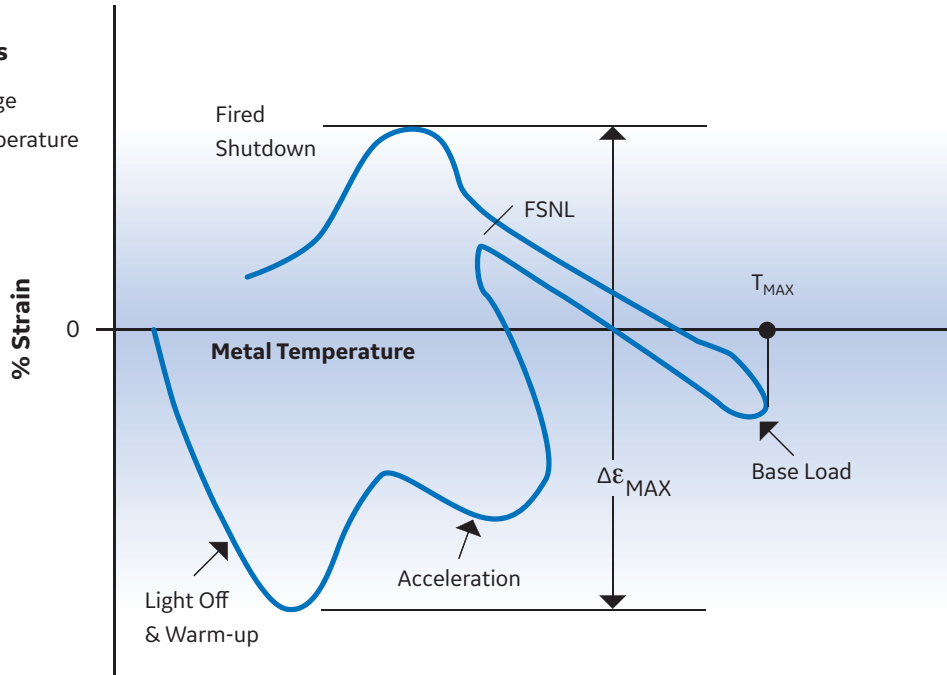

**Figure 17.** Representative Bucket low cycle fatigue (LCF)"

Figure 18 compares a normal operating cycle with one that includes a trip from full load. The significant increase in the strain range for a trip cycle results in a life effect that equates to eight normal start/stop cycles, as shown. Trips from part load will have a reduced effect because of the lower metal temperatures at the initiation of the trip event. Figure 19 illustrates that while a trip from between 80% and 100% load has an 8:1 trip severity factor, a trip from full speed no load (FSNL) has a trip severity factor of 2:1. Similarly, overfiring

of the unit during peak load operation leads to increased component metal temperatures. As a result, a trip from peak load has a trip severity factor of 10:1.

Trips are to be assessed in addition to the regular startup/shutdown cycles as starts adds. As such, in the factored starts equation of Figure 42, one is subtracted from the severity factor so that the net result of the formula (Figure 42) is the same as that dictated by the increased strain range. For example, a startup and trip

**Leading Edge Temperature/Strain**

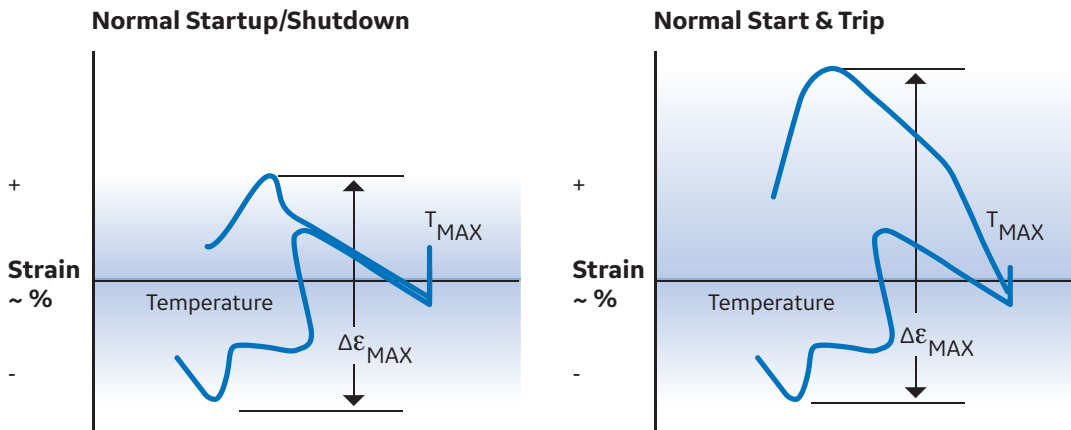

1 Trip Cycle = 8 Normal Shutdown Cycles

**Figure 18.** Representative Bucket low cycle fatigue (LCF)



from base load would count as eight total cycles (one cycle for startup to base load plus 8-1=7 cycles for trip from base load), just as indicated by the 8:1 maintenance factor.

Similarly to trips from load, peaking-fast starts will affect the starts-based maintenance interval. Like trips, the effects of a peaking-fast start on the machine are considered separate from a normal cycle and their effects must be tabulated in addition to the normal start/stop cycle. However, there is no -1 applied to these factors, so a 7F.03 peaking-fast start during a base load cycle would have a total effect of 1.5 cycles. Refer to *Appendix A* for factored starts examples, and consult unit-specific documentation to determine if an alternative hot gas path peaking-fast start factor applies.

While the factors described above will decrease the starts-based maintenance interval, part load operating cycles allow for an extension of the maintenance interval. *Figure 20* can be used in considering this type of operation. For example, two operating cycles to maximum load levels of less than 60% would equate to one start to a load greater than 60% or, stated another way, would have a maintenance factor of 0.5.

Factored starts calculations are based upon the maximum load achieved during operation. Therefore, if a unit is operated at part load for three weeks, and then ramped up to base load for the last ten minutes, then the unit's total operation would be described as a base load start/stop cycle.

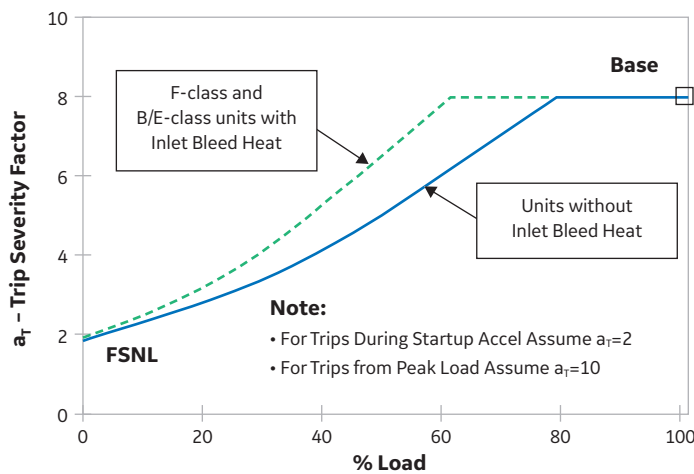

Figure 19. Maintenance factor – trips from load

## Rotor Parts

The maintenance and refurbishment requirements of the rotor structure, like the hot gas path components, are affected by the cyclic effects of startup, operation, and shutdown, as well as loading and off-load characteristics. Maintenance factors specific to the operating profile and rotor configuration must be incorporated into the operator's maintenance planning. A GE Rotor life extension is required when the accumulated rotor factored fired starts or hours reach the inspection limit. (See *Figure 43* and *Figure 44* in the Inspection Intervals section.)

The thermal condition when the startup sequence is initiated is a major factor in determining the rotor maintenance interval and individual rotor component life. Rotors that are cold when the startup commences experience transient thermal stresses as the turbine is brought on line. Large rotors with their longer thermal time constants develop higher thermal stresses than smaller rotors undergoing the same startup time sequence. High thermal stresses reduce thermal mechanical fatigue life and the inspection interval.

In addition to the startup thermal condition, the rotor shutdown thermal condition can influence the rotor maintenance factor as well. A normal rotor cool down following a normal fired shutdown or trip relies heavily on natural convection for cool down of the rotor structure at turning gear/ratchet speed as discussed in *Figure F-1*. However, an operator may elect to perform a rapid/forced/crank cool down (see Rapid Cool-Down, page 23) which is defined as when an operator creates a forced convection cooling flow thru the unit by operating the rotor at an

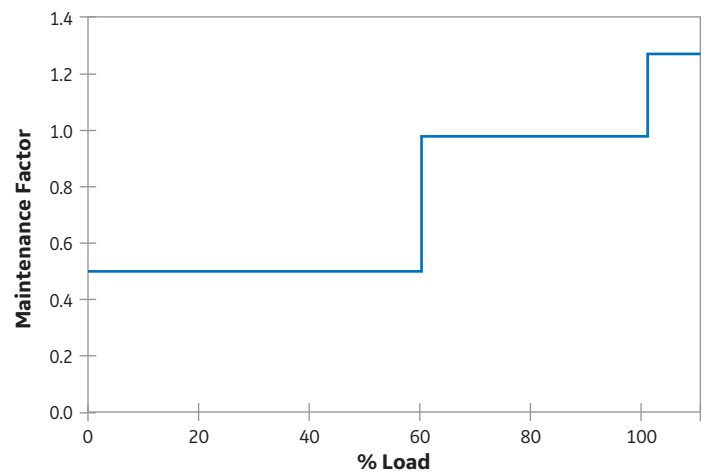

Figure 20. Maintenance factor – effect of start cycle maximum load level

increased mechanical speed (typically purge speed) after a normal shutdown or trip to achieve a faster than normal cool down of the rotor structure. This accelerated cooling down of the rotor has transient thermal effects which increase the thermal mechanical fatigue damage to the rotor structure.

Initial rotor thermal condition is not the only operating factor that influences rotor maintenance intervals and component life. Peaking-fast starts, where the turbine is ramped quickly to load, also increase thermal gradients on the rotor.

Though the concept of rotor maintenance factors is applicable to all gas turbine rotors, only F-class rotors will be discussed in detail. For all other rotors, reference unit-specific documentation to determine additional maintenance factors that may apply. The rotor maintenance factor for a startup is a function of the downtime following a previous period of operation. As downtime increases, the rotor metal temperature approaches ambient conditions, and thermal fatigue during a subsequent startup increases. As such, cold starts are assigned a rotor maintenance factor of two and hot starts a rotor maintenance factor of less than one due to the lower thermal stress under hot conditions. This effect varies from one location in the rotor structure to another. The most limiting location determines the overall rotor maintenance factor.

Figure 21 lists recommended operating factors that should be used to determine the rotor’s overall maintenance factor for certain F-class rotors. The physics governing the thermal stresses and mechanical fatigue are similar for FA.05 and 6F.01 class rotors; however, F-class factors may not be appropriate for inspection intervals see unit specific documentation. Refer to technical information letters for HA rotor maintenance factors.

The significance of each of these factors is dependent on the unit operation. There are three categories of operation that are typical of most gas turbine applications. These are peaking, cyclic, and continuous duty as described below:

- Peaking units have a relatively high starting frequency and a low number of hours per start. Operation follows a seasonal demand. Peaking units will generally see a high percentage of warm and cold starts.
- Cyclic units start daily with weekend shutdowns. Twelve to sixteen hours per start is typical, which results in a warm rotor

condition for a large percentage of the starts. Cold starts are generally seen only after a maintenance outage or following a two-day weekend outage.

- Continuous duty applications see a high number of hours per start. Most starts are cold because outages are generally maintenance driven. While the percentage of cold starts is high, the total number of starts is low. The rotor maintenance interval on continuous duty units will be determined by operating hours rather than starts.

Figure 22 lists reference operating profiles of these three general categories of gas turbine applications. These duty cycles have different combinations of hot, warm, and cold starts with each starting condition having a different effect on rotor maintenance

#### F, FA, and FB\*-class Rotors

	Rotor Maintenance Factors	
	Peaking-Fast Start**	Normal Start
Hot 1 Start Factor (0 < downtime ≤ 1 hour) ****	4.0	2.0
Hot 2 Start Factor (1 hour < downtime ≤ 4 hours) ****	1.0	0.5
Warm 1 Start Factor (4 hours < downtime ≤ 20 hours) ****	1.8	0.9
Warm 2 Start Factor (20 hours < downtime ≤ 40 hours) ****	2.8	1.4
Cold Start Factor (Downtime > 40 hours)****	4.0	2.0
Rapid/Forced/Crank Cooling Shutdown ***	4.0	4.0
* Other factors may apply to early 9F.03 units.		
** An F-class peaking-fast start is typically a start in which the unit is brought from ignition to full load in less than 15 minutes.		
*** If a unit is on turning gear/ratchet after normal shutdown or trip for more than 8 hours prior to Rapid/Forced/Crank cooling being initiated, this factor is equal to 0.0 as outlined in Figure 44		
**** Downtime hours counted from time unit reaches turning gear/ratchet until initiation of next start.		

Figure 21. Operation-related maintenance factors

	Peaking	Cyclic	Continuous
Hot 2 Start Factor (1 hour < downtime ≤ 4 hours)	3%	1%	10%
Warm 1 Start Factor (4 hours < downtime ≤ 20 hours)	10%	82%	5%
Warm 2 Start Factor (20 hours < downtime ≤ 40 hours)	37%	13%	5%
Cold Start Factor (Downtime > 40 hours)	50%	4%	80%
Hours/Start	4	16	400
Hours/Year	600	4800	8200
Starts/Year	150	300	21
Percent Rapid/Forced/ Crank Cools	3%	1%	10%
Rapid/Forced/Crank Cooling Shutdown/Year	5	3	2
Typical Maintenance Factor (Starts-Based)	1.7	1.0	NA
<ul style="list-style-type: none"> <li>Operational Profile is Application Specific</li> <li>Inspection Interval is Application Specific</li> </ul>			

**Figure 22.** 7F/7FA gas turbine reference operational profile

interval as previously discussed. As a result, the starts-based rotor maintenance interval will depend on an application's specific duty cycle. In the Rotor Inspection Interval section, a method will be described to determine a maintenance factor that is specific to the operation's duty cycle. The application's integrated maintenance factor uses the rotor maintenance factors described above in combination with the actual duty cycle of a specific application and can be used to determine rotor inspection intervals. In this calculation, the reference duty cycle that yields a starts-based maintenance factor equal to one is defined in *Figure 23*. Duty cycles different from the *Figure 23* definition, in particular duty cycles with more cold starts or a high number of rapid/forced/crank cool operations, will have a maintenance factor greater than one.

Turning gear or ratchet operation after shutdown and before starting/restarting is a crucial part of normal operating procedure. After a shutdown, turning of the warm rotor is essential to avoid

bow, or bend, in the rotor. Initiating a start with the rotor in a bowed condition could lead to high vibrations and excessive rubs. *Figure F-1* describes turning gear/ratchet scenarios and operation guidelines (See *Appendix*). Relevant operating instructions and TILs should be adhered to where applicable. As a best practice, units should remain on turning gear or ratchet following a planned shutdown until wheelspace temperatures have stabilized at or near ambient temperature. If the unit is to see no further activity for 48 hours after cool-down is completed, then it may be taken off of turning gear.

*Figure F-1* also provides guidelines for hot restarts. When an immediate restart is required, it is recommended that the rotor be placed on turning gear for one hour following a trip from load, trip from full speed no load, or normal shutdown. This will allow transient thermal stresses to subside before superimposing a startup transient. If the machine must be restarted in less than one hour, a start factor of 2 will apply.

Longer periods of turning gear operation may be necessary prior to a cold start or hot restart if bow is detected. Vibration data taken while at crank speed can be used to confirm that rotor bow is at acceptable levels and the start sequence can be initiated. Users should reference the O&M Manual and appropriate TILs for specific instructions and information for their units.

#### Baseline Unit

Cyclic Duty			
6	Starts/Week		
16	Hours/Start		
4	Outage/Year Maintenance		
50	Weeks/Year		
4800	Hours/Year		
300	Starts/Year		
	12	Cold Starts/Year	4%
	39	Warm 2 Starts/Year	13%
	246	Warm 1 Starts/Year	82%
	3	Hot 2 Starts/Year	1%
	0	Rapid/Forced/Crank Cools/Year	
	1	Maintenance Factor	
Baseline Unit Achieves Maintenance Factor = 1			

**Figure 23.** Baseline for starts-based maintenance factor definition

## Combustion Parts

From hardware configuration standpoint, GE combustion hardware configuration include transition pieces, combustion liners, combustion unibodies, combustor cones, flow sleeves, head-end assemblies containing fuel nozzles and cartridges, end caps and end covers, and assorted other hardware parts including cross-fire tubes, spark plugs and flame detectors. In addition, there are various fuel and air delivery components such as purge or check valves and flexible hoses.

GE offers several types of combustion systems configurations: Standard combustors, Multi-Nozzle Quiet Combustors (MNQC), Integrated Gasification Combined Cycle (IGCC) combustors, and Dry Low NO<sub>x</sub> (DLN) combustors. The GE Annular/Silo Fleet offers further combustion systems: Silo combustors with single burners (SB) for Natural or LBTu gases or multiple EnVironmental burners (EV), furthermore Annular combustors with EnVironmental Burners (EV), Advanced EnVironmental Burners (AEV) and Sequential EnVironmental Burners (SEV). Each of the combustion configurations mentioned above, has specific gas or liquid fuel operating characteristics that affect differently combustion hardware factored maintenance intervals and refurbishment requirements.

Gas turbines fitted with DLN combustion systems operate in incremental combustion modes to reach to base load operation. A combustion mode constitutes a range of turbine load where fuel delivery in combustion cans is performed via certain combination of fuel nozzles or fuel circuits within the fuel nozzles. For example, for DLN 2.6 combustion systems, mode 3 refers to the load range

when fuel is being delivered to PM 1 (Premix 1) and PM 2 (Premix 2) fuel nozzles through gas control valves PM 1 and PM 2.

Combustion modes change when turbine load, and consequently combustion reference temperature value (TTRF1 or CRT) crosses threshold values defining the initiation of next combustion mode.

- **Continuous mode operation** mentioned in this section refers to intentional turbine operation in a certain combustion mode for longer than what typically takes during normal startup/shutdown.
- **Extended mode operation** mentioned in this sections is possible in DLN1/1+ and DLN2/2+ combustion configuration only, where the controls logics can be forced to extend a Lean-Lean Mode or Piloted Premixed Mode beyond the turbine load corresponding to a normal combustion mode transfer (as defined via TTRF1 or CRT values).

From operational standpoint, earlier DLN combustion configurations such as DLN1/1+, DLN2/2+ use diffusion combustion (non-Premix) at part load before reaching the low emissions combustion mode (Premix). These combustion modes nomenclatures are referred to as Lean-Lean, extended Lean-Lean, sub-Piloted Premix and Piloted Premix Modes. General recommendation for continuous mode operation is in the combustion mode that provides guaranteed emissions, which is the premixed combustion mode (PM). This combustion mode is also the most beneficial operation mode for ensuring expected hardware life.

Continuous and extended mode operation in non-PM combustion modes is not recommended due to reduction in combustion hardware life as shown in *Figure 24*.

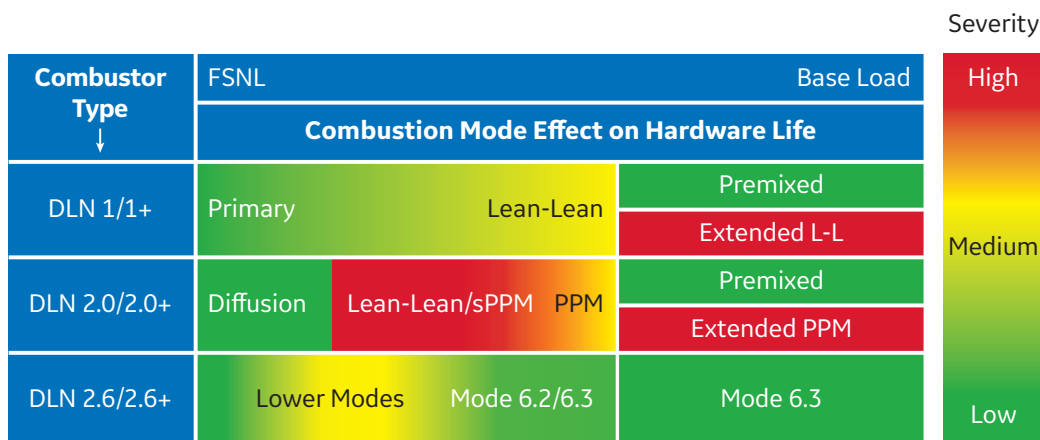

**Figure 24:** DLN combustion mode effect on combustion hardware

The use of non-emissions compliant combustion modes can affect the factored maintenance intervals of combustion hardware as shown below:

- DLN-1/DLN-1+ extended lean-lean operation results in a maintenance factor of 10. Nimonic 263 will have a maintenance factor of 4.
- DLN 2.0/DLN 2+ extended piloted premixed operation results in a maintenance factor of 10.
- Continuous mode operation in Lean-Lean (L-L), sub-Piloted Premixed (sPPM), or Piloted Premixed (PPM) modes is not recommended as it will accelerate combustion hardware degradation.
- In addition, cyclic operation between piloted premixed and premixed modes leads to thermal loads on the combustion liner and transition piece similar to the loads encountered during the startup/shutdown cycle.

Another factor that can affect combustion system maintenance is acoustic dynamics. Acoustic dynamics are pressure oscillations generated by the combustion process within the combustion chambers, which when are present at high levels can lead to significant wear of combustion or hot gas path components. Common GE practice is to tune the combustion system to levels of acoustic dynamics deemed low enough not to affect life of gas turbine hardware. In addition, GE encourages monitoring of combustion dynamics during turbine operation throughout the full range of ambient temperatures and loads.

Combustion disassembly is performed, during scheduled combustion inspections (CI). Inspection interval guidelines are included in *Figure 36*. It is expected, and recommended, that intervals be modified based on specific experience. Replacement intervals are usually defined by a recommended number of combustion (or repair) intervals and are usually combustion component specific. In general, the replacement interval as a function of the number of combustion inspection intervals is reduced if the combustion inspection interval is extended. For example, a component having an 8,000-hour CI interval, and a six CI replacement interval, would have a replacement interval of four CI intervals if the inspection intervals were increased to 12,000 hours (to maintain a 48,000-hour replacement interval).

For combustion parts, the baseline operating conditions that result in a maintenance factor of one are fired startup and shutdown to base load on natural gas fuel without steam or water injection. Factors that increase the hours-based maintenance factor include peak load operation, distillate or heavy fuels, and steam or water injection. Factors that increase starts-based maintenance factor include peak load start/stop cycles, distillate or heavy fuels, steam or water injection, trips, and peaking-fast starts.

## Casing Parts

Most GE gas turbines have inlet, compressor, compressor discharge, and turbine cases in addition to exhaust frames. Inner barrels are typically attached to the compressor discharge case. These cases provide the primary support for the bearings, rotor, and gas path hardware.

The exterior of all casings should be visually inspected for cracking, loose hardware, and casing slippage at each combustion, hot gas path, and major outage. The interior of all casings should be inspected whenever possible. The level of the outage determines which casing interiors are accessible for visual inspection. Borescope inspections are recommended for the inlet cases, compressor cases, and compressor discharge cases during gas path borescope inspections. All interior case surfaces should be inspected visually, digitally, or by borescope during a major outage.

Key inspection areas for casings are listed below.

- Bolt holes
- Shroud pin and borescope holes in the turbine shell (case)
- Compressor stator hooks
- Turbine shell shroud hooks
- Compressor discharge case struts
- Inner barrel and inner barrel bolts
- Inlet case bearing surfaces and hooks
- Inlet case and exhaust frame gibs and trunions
- Extraction manifolds (for foreign objects)

## Exhaust Diffuser Parts

GE exhaust diffusers come in either axial or radial configurations as shown in *Figures 25 and 26* below. Both types of diffusers are composed of a forward and aft section. Forward diffusers are normally axial diffusers, while aft diffusers can be either axial or radial. Axial diffusers are used in the F and HA-class gas turbines, while radial diffusers are used in B/E-class gas turbines.

Exhaust diffusers are subject to high gas path temperatures and vibration due to normal gas turbine operation. Because of the extreme operating environment and cyclic operating nature of gas turbines, exhaust diffusers may develop cracks in the sheet metal surfaces and weld joints used for diffuser construction. Additionally, erosion may occur due to extended operation at high temperatures. Exhaust diffusers should be inspected as follows at every combustion, hot gas path and major outage. The inspections shall only be performed when the unit is shut down; and following site health and safety procedures.

- Internal inspection for:
  - Cracking, erosion, and distortion
  - Missing or visually damaged hardware.
- External inspection for:
  - Evidence of gas leaks
  - Visual damage on aft support legs (plus spring support, if available)
  - Visual damage or distortion of the diffuser outer surface.

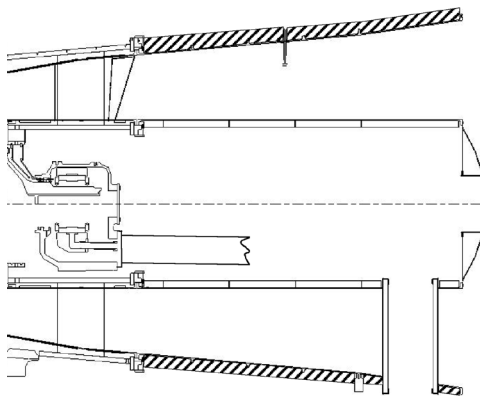

**Figure 25.** F-class axial diffuser

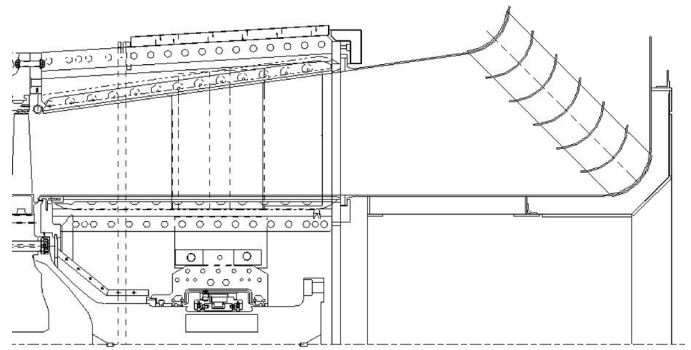

**Figure 26.** E-class radial diffuser

In addition, flex seals, L-seals, and horizontal joint gaskets should be visually/borescope inspected for signs of wear or damage at every combustion, hot gas path, and major outage. GE recommends that seals with signs of wear or damage be replaced.

To summarize, key areas that should be inspected are listed below. Any damage should be reported to GE for recommended repairs.

- Forward diffuser carrier flange (6F)
- Diffuser strut airfoil leading and trailing edges
- Turning vanes in radial diffusers (B/E-class)
- Insulation packs on interior or exterior surfaces
- Clamp ring attachment points to exhaust frame (major outage only)
- Flex seals and L-seals
- Horizontal joint gaskets

## Off-Frequency Operation

GE heavy-duty single shaft gas turbines are engineered to operate at 100% speed with the capability to operate over approximately a 94% to 105% speed range. Operation at other than rated speed has the potential to affect maintenance requirements. Depending on the industry code requirements, the specifics of the turbine configuration, and the turbine control philosophy employed, operating conditions can result that will accelerate life consumption of gas turbine components, particularly rotating flowpath hardware. Where this is true, the maintenance factor associated with this operation must be understood. These off-frequency events must be analyzed and recorded in order to include them in the maintenance plan for the gas turbine.



Some turbines are required to meet operational requirements that are aimed at maintaining grid stability under sudden load or capacity changes. Most codes require turbines to remain on line in the event of a frequency disturbance. For under-frequency operation, the turbine output may decrease with a speed decrease, and the net effect on the turbine is minimal.

In some cases of under-frequency operation, turbine output lapse must be compensated in order to meet the specification-defined output requirement. If the normal output fall-off with speed results in loads less than the defined minimum, the turbine must compensate. Turbine overfiring is the most obvious compensation option, but other means, such as inlet guide vane opening, water-wash, inlet fogging, or evaporative cooling also provide potential means for compensation. A maintenance factor may need to be applied for some of these methods. In addition, off-frequency operation, including rapid Rate of Change of Frequency, may expose the compressor, combustion, and turbine components to high stress and reduce fatigue life. When frequency deviation withstand requirements are combined with active power response requirement (also known as governor response), a start-based penalty may be incurred to consider the accelerated life consumption of the flowpath hardware.

It is important to understand that operation at over-frequency conditions will not trade one-for-one for periods at under-frequency conditions. As was discussed in the firing temperature section above, operation at peak firing conditions has a nonlinear, logarithmic relationship with maintenance factor.

### Over Speed Operation Constant T<sub>fire</sub>

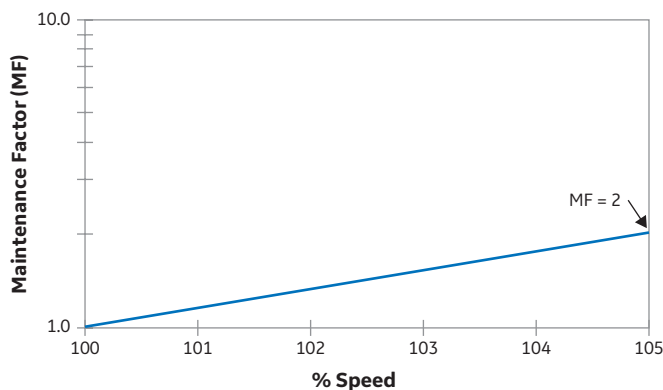

Figure 27. Maintenance factor for overspeed operation - constant T<sub>fire</sub>

Over-frequency or high speed operation can also introduce conditions that affect turbine maintenance and part replacement intervals. If speed is increased above the nominal rated speed, the rotating components see an increase in mechanical stress proportional to the square of the speed increase. If firing temperature is held constant at the overspeed condition, the life consumption rate of hot gas path rotating components will increase as illustrated in Figure 27 where one hour of operation at 105% speed is equivalent to two hours at rated speed.

If overspeed operation represents a small fraction of a turbine's operating profile, this effect on parts life can sometimes be ignored. However, if significant operation at overspeed is expected and rated firing temperature is maintained, the accumulated hours must be recorded and included in the calculation of the turbine's overall maintenance factor and the maintenance schedule adjusted to reflect the overspeed operation.

### Compressor Condition and Performance

Maintenance and operating costs are also influenced by the quality of the air that the turbine consumes. In addition to the negative effects of airborne contaminants on hot gas path components, contaminants such as dust, salt, and oil can cause compressor blade erosion, corrosion, and fouling.

Fouling can be caused by submicron dirt particles entering the compressor as well as from ingestion of oil vapor, smoke, sea salt, and industrial vapors. Corrosion of compressor blading causes pitting of the blade surface, which, in addition to increasing the surface roughness, also serves as potential sites for fatigue crack initiation. These surface roughness and blade contour changes will decrease compressor airflow and efficiency, which in turn reduces the gas turbine output and overall thermal efficiency. Generally, axial flow compressor deterioration is the major cause of loss in gas turbine output and efficiency. Recoverable losses, attributable to compressor blade fouling, typically account for 70-85% percent of the performance losses seen. As Figure 28 illustrates, compressor fouling to the extent that airflow is reduced by 5%, will reduce output by up to 8% and increase heat rate by up to 3%. Fortunately, much can be done through proper operation and maintenance procedures both to reduce fouling type losses and to limit the deposit of

corrosive elements. On-line compressor wash systems are available to maintain compressor efficiency by washing the compressor while at load, before significant fouling has occurred. Off-line compressor wash systems are used to clean heavily fouled compressors. Other procedures include maintaining the inlet filtration system, inlet evaporative coolers, and other inlet systems as well as periodic inspection and prompt repair of compressor blading. Refer to system-specific maintenance manuals.

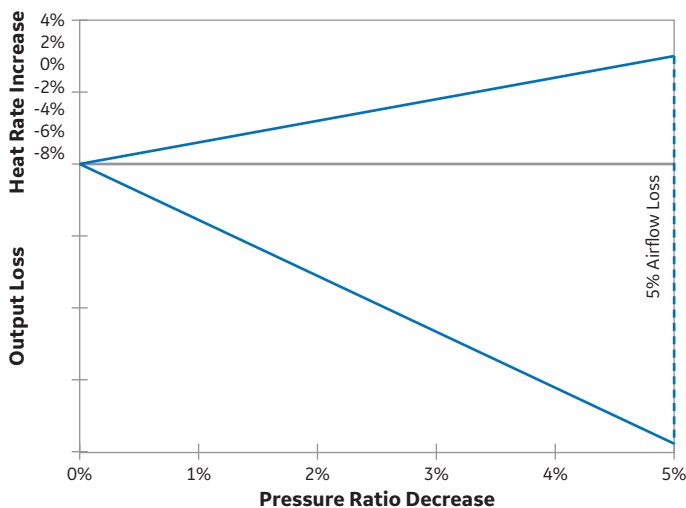

**Figure 28.** Deterioration of gas turbine performance due to compressor blade fouling

There are also non-recoverable losses. In the compressor, these are typically caused by nondeposit-related blade surface roughness, erosion, and blade tip rubs. In the turbine, nozzle throat area changes, bucket tip clearance increases and leakages are potential causes. Some degree of unrecoverable performance degradation should be expected, even on a well-maintained gas turbine. The owner, by regularly monitoring and recording unit performance parameters, has a very valuable tool for diagnosing possible compressor deterioration.

### Lube Oil Cleanliness

Contaminated or deteriorated lube oil can cause wear and damage to bearing liners. This can lead to extended outages and costly repairs. Routine sampling of the turbine lube oil for proper viscosity, chemical composition, and contamination is an essential part of a complete maintenance plan.

Lube oil should be sampled and tested per GEK-32568, “Lubricating Oil Recommendations for Gas Turbines with Bearing Ambients Above 500°F (260°C).” Additionally, lube oil should be checked periodically for particulate and water contamination as outlined in GEK-110483, “Cleanliness Requirements for Power Plant Installation, Commissioning and Maintenance.” At a minimum, the lube oil should be sampled on a quarterly basis; however, monthly sampling is recommended.

### Moisture Intake

One of the ways some users increase turbine output is through the use of inlet foggers. Foggers inject a large amount of moisture in the inlet ducting, exposing the forward stages of the compressor to potential water carry-over. Operation of a compressor in such an environment may lead to long-term degradation of the compressor due to corrosion, erosion, fouling, and material property degradation. Experience has shown that depending on the quality of water used, the inlet silencer and ducting material, and the condition of the inlet silencer, fouling of the compressor can be severe with inlet foggers. Similarly, carryover from evaporative coolers and water washing more than recommended can degrade the compressor. The water quality standard that should be adhered to is found in GEK-101944, “Requirements for Water/Steam Purity in Gas Turbines.” Water carry-over may subject blades and vanes to corrosion and associated pitting. Such corrosion may be accelerated by a saline environment (see GER-3419). Reductions in fatigue strength may result if the environment is acidic and if pitting is present on the blade. This condition is exacerbated by downtime in humid environments, which promotes wet corrosion.

Water droplets may cause leading edge erosion up to and through the middle stages of the compressor. This erosion, if sufficiently developed, may lead to an increased risk of blade failure. Online water washing may also cause some leading edge erosion on the forward stage compressor blades and vanes. To mitigate this erosion risk, safeguards are in-place that control the amount of water used, frequency of usage, and radial location of water wash nozzles.



## Maintenance Inspections

Maintenance inspection types may be broadly classified as standby, running, and disassembly inspections. The standby inspection is performed during off-peak periods when the unit is not operating and includes routine servicing of accessory systems and device calibration. The running inspection is performed by observing key operating parameters while the turbine is running. The disassembly inspection requires opening the turbine for inspection of internal components. Disassembly inspections progress from the combustion inspection to the hot gas path inspection to the major inspection as shown in *Figure 29*. Details of each of these inspections are described below. The section ABC Inspections describes the maintenance inspections for the GE Annular/Silo Fleet.

### Standby Inspections

Standby inspections are performed on all gas turbines but pertain particularly to gas turbines used in peaking and intermittent-duty service where starting reliability is of primary concern. This inspection includes routinely servicing the battery system, changing filters, checking oil and water levels, cleaning relays, and checking device calibrations. Servicing can be performed in off-peak periods without interrupting the availability of the turbine. A periodic startup test run is an essential part of the standby inspection.

The O&M Manual, as well as the Service Manual Instruction Books, contains information and drawings necessary to perform these periodic checks. Among the most useful drawings in the Service Manual Instruction Books for standby maintenance are the control specifications, piping schematics, and electrical elementaries. These drawings provide the calibrations, operating limits, operating characteristics, and sequencing of all control devices. This information should be used regularly by operating and maintenance personnel. Careful adherence to minor standby inspection maintenance can have a significant effect on reducing overall maintenance costs and maintaining high turbine reliability. It is essential that a good record be kept of all inspections and maintenance work in order to ensure a sound maintenance program.

### Running Inspections

Running inspections consist of the general and continued observations made while a unit is operating. This starts by establishing baseline operating data during startup of a new unit and after any major disassembly work. This baseline then serves as a reference from which subsequent unit deterioration can be measured.

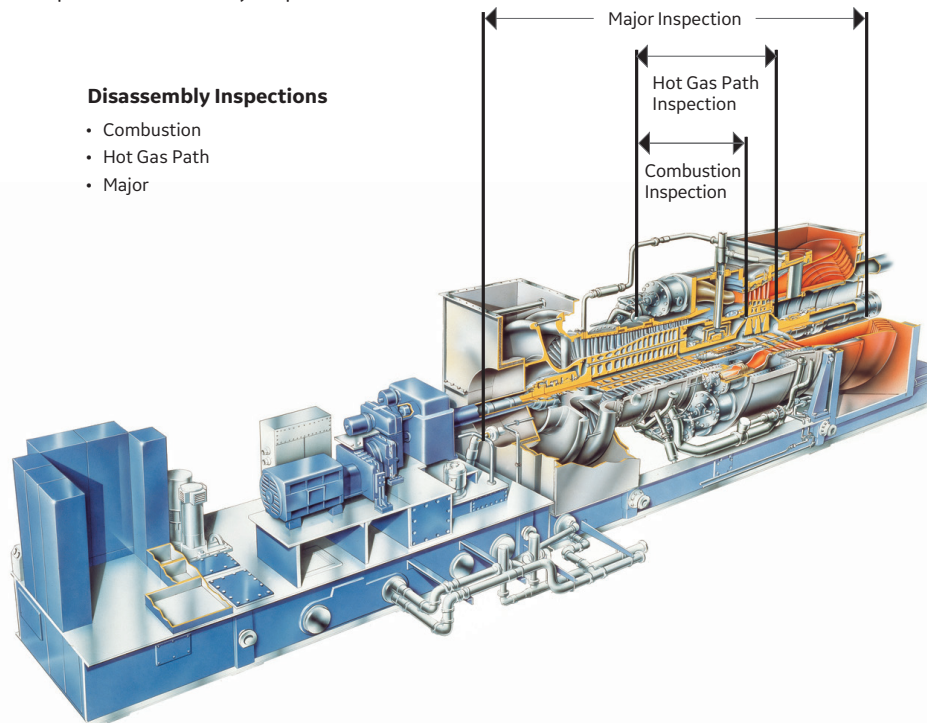

**Figure 29.** 7E.03 heavy-duty gas turbine – disassembly inspections

Data should be taken to establish normal equipment startup parameters as well as key steady state operating parameters. Steady state is defined as conditions at which no more than a 5°F/3°C change in wheelspace temperature occurs over a 15-minute time period. Data must be taken at regular intervals and should be recorded to permit an evaluation of the turbine performance and maintenance requirements as a function of operating time. This operating inspection data, summarized in *Figure 30*, includes: load versus exhaust temperature, vibration level, fuel flow and pressure, bearing metal temperature, lube oil pressure, exhaust gas temperatures, exhaust temperature spread variation, startup time, and coast-down time. This list is only a minimum and other parameters should be used as necessary. A graph of these parameters will help provide a basis for judging the conditions of the system. Deviations from the norm help pinpoint impending issues, changes in calibration, or damaged components.

• <b>Speed</b>	
• <b>Load</b>	
• <b>Fired Starts</b>	
• <b>Fired Hours</b>	
• <b>Temperatures</b>	
– Inlet Ambient	– Lube Oil Tank
– Compressor Discharge	– Bearing Metal
– Turbine Exhaust	– Bearing Drains
– Turbine Wheelspace	– Exhaust Spread
– Lube Oil Header	
• <b>Pressures</b>	
– Compressor Discharge	– Cooling Water
– Lube Pump(s)	– Fuel
– Bearing Header	– Filters (Fuel, Lube, Inlet Air)
– Barometric	
• <b>Vibration</b>	
• <b>Generator</b>	
– Output Voltage	– Field Voltage
– Phase Current	– Field Current
– VARS	– Stator Temp.
– Load	– Vibration
• <b>Startup Time</b>	
• <b>Coast-Down Time</b>	

**Figure 30.** Operating inspection data parameters

A sudden abnormal change in running conditions or a severe trip event could indicate damage to internal components. Conditions that may indicate turbine damage include high vibration, high exhaust temperature spreads, compressor surge, abnormal changes in health monitoring systems, and abnormal changes in other monitoring systems. It is recommended to conduct a borescope inspection after such events whenever component damage is suspected.

### Load vs. Exhaust Temperature

The general relationship between load and exhaust temperature should be observed and compared to previous data. Ambient temperature and barometric pressure will have some effect upon the exhaust temperature. High exhaust temperature can be an indicator of deterioration of internal parts, excessive leaks or a fouled air compressor. For mechanical drive applications, it may also be an indication of increased power required by the driven equipment.

### Vibration Level

The vibration signature of the unit should be observed and recorded. Minor changes will occur with changes in operating conditions. However, large changes or a continuously increasing trend give indications of the need to apply corrective action.

### Fuel Flow and Pressure

The fuel system should be observed for the general fuel flow versus load relationship. Fuel pressures through the system should be observed. Changes in fuel pressure can indicate that the fuel nozzle passages are plugged or that fuel-metering elements are damaged or out of calibration.

### Exhaust Temperature and Spread Variation

The most important control function to be monitored is the exhaust temperature fuel override system and the back-up over temperature trip system. Routine verification of the operation and calibration of these functions will minimize wear on the hot gas path parts.

### Startup Time

Startup time is a reference against which subsequent operating parameters can be compared and evaluated. A curve of the starting parameters of speed, fuel signal, exhaust temperature, and critical sequence bench marks versus time will provide a

good indication of the condition of the control system. Deviations from normal conditions may indicate impending issues, changes in calibration, or damaged components.

### Coast-Down Time

Coast-down time is an indicator of bearing alignment and bearing condition. The time period from when the fuel is shut off during a normal shutdown until the rotor comes to turning gear speed can be compared and evaluated.

Close observation and monitoring of these operating parameters will serve as the basis for effectively planning maintenance work and material requirements needed for subsequent shutdown periods.

### Rapid Cool-Down

Prior to an inspection, a common practice is to force cool the unit to speed the cool-down process and shorten outage time. Force cooling involves turning the unit at crank speed for an extended period of time to continue flowing ambient air through the machine. This is permitted, although a natural cool-down cycle on turning gear or ratchet is preferred for normal shutdowns when no outage is pending. Forced cooling should be limited since it imposes additional thermal stresses on the unit that may result in a reduction of parts life. Opening the compartment doors during any cool-down operation is prohibited unless an emergency situation requires immediate compartment inspection. Cool-down times should not be accelerated by opening the compartment doors or lagging panels, since uneven cooling of the outer casings may result in excessive case distortion and heavy blade rubs. Cool-down is considered complete when all wheelspace temperatures are below 150°F when measured at turning gear/ratchet speed.

### Combustion Inspection

The combustion inspection is a relatively short disassembly inspection of fuel nozzles, liners, transition pieces, crossfire tubes and retainers, spark plug assemblies, flame detectors, and combustor flow sleeves. This inspection concentrates on the combustion liners, transition pieces, fuel nozzles, and end caps, which are recognized as being the first to require replacement and repair in a good maintenance program. Proper inspection, maintenance, and repair (*Figure 31*) of these items will contribute to a longer life of the downstream parts, such as turbine nozzles and buckets.

*Figure 29* illustrates the section of a 7E.03 unit that is disassembled for a combustion inspection. The combustion liners, transition pieces, and fuel nozzle assemblies should be removed and replaced with new or repaired components to reduce downtime. The removed liners, transition pieces, and fuel nozzles can then be cleaned and repaired after the unit is returned to operation and be available for the next combustion inspection interval. Typical combustion inspection requirements are:

- Inspect combustion chamber components.
- Inspect each crossfire tube, retainer and combustion liner.
- Inspect combustion liner for TBC spalling, wear, and cracks.
- Inspect combustion system and discharge casing for debris and foreign objects.
- Inspect flow sleeve welds for cracking.
- Inspect transition piece for wear and cracks.
- Inspect fuel nozzles for plugging at tips, erosion of tip holes, and safety lock of tips.
- Inspect impingement sleeves for cracks (where applicable).
- Inspect all fluid, air, and gas passages in nozzle assembly for plugging, erosion, burning, etc.
- Inspect spark plug assembly for freedom from binding; check condition of electrodes and insulators.
- Replace all consumables and normal wear-and-tear items such as seals, lockplates, nuts, bolts, gaskets, etc.
- Perform visual inspection of first-stage turbine nozzle partitions and borescope inspect (*Figure 3*) turbine buckets to mark the progress of wear and deterioration of these parts. This inspection will help establish the schedule for the hot gas path inspection.
- Perform borescope inspection of compressor.
- Visually inspect the compressor inlet, checking the condition of the inlet guide vanes (IGVs) and VSVs, where applicable, IGV bushings and VSV bushings, where applicable, and first stage rotating blades.
- Check the condition of IGV actuators and VSV actuators, where applicable, and rack-and-pinion gearing.
- Verify the calibration of the IGVs and VSVs, where applicable.

- Visually inspect compressor discharge case struts for signs of cracking.
- Visually inspect compressor discharge case inner barrel if accessible.
- Visually inspect the last-stage buckets and shrouds.
- Visually inspect the exhaust diffuser for any cracks in flow path surfaces. Inspect insulated surfaces for loose or missing insulation and/or attachment hardware in internal and external locations. In B/E-class machines, inspect the insulation on the radial diffuser and inside the exhaust plenum as well.
- Inspect exhaust frame flex seals, L-seals, and horizontal joint gaskets for any signs of wear or damage.

- Verify proper operation of purge and check valves. Confirm proper setting and calibration of the combustion controls.
- Inspect turbine inlet systems including filters, evaporative coolers, silencers, etc. for corrosion, cracks, and loose parts.

After the combustion inspection is complete and the unit is returned to service, the removed combustion hardware can be inspected by a qualified GE field service representative and, if necessary, sent to a qualified GE Service Center for repairs. It is recommended that repairs and fuel nozzle flow testing be performed at qualified GE service centers.

See the O&M Manual for additional recommendations and unit specific guidance.

### Combustion Inspection

Key Hardware	Inspect For	Potential Action
Combustion liners	Foreign object damage (FOD)	Repair/refurbish/replace
Combustion end covers	Abnormal wear	• Transition Pieces • Fuel nozzles
Fuel nozzles	Cracking	– Strip and recoat – Weld repair
End caps	Liner cooling hole plugging	– Weld repair – Flow test
Transition pieces	TBC coating condition	– Creep repair – Leak test
Cross fire tubes	Oxidation/corrosion/erosion	• Liners
Flow sleeves	Hot spots/burning	– Strip and recoat
Purge valves	Missing hardware	– Weld repair
Check valves	Clearance limits	– Hula seal replacement
Spark plugs		– Repair out-of-roundness
Flame detectors		
Flex hoses		
IGV and VSV and bushings		
Compressor and turbine (borescope)		
Exhaust diffuser	→ Cracks	→ Weld repair
Exhaust diffuser Insulation	→ Loose/missing parts	→ Replace/tighten parts
Forward diffuser flex seal	→ Wear/cracked parts	→ Replace seals
Compressor discharge case	→ Cracks	→ Repair or monitor
Cases – exterior	→ Cracks	→ Repair or monitor

Criteria	Inspection Methods	Availability of On-Site Spares is Key to Minimizing Downtime
<ul style="list-style-type: none"> <li>• O&amp;M Manual</li> <li>• GE Field Engineer</li> </ul>	<ul style="list-style-type: none"> <li>• TILs</li> <li>• Visual</li> <li>• Borescope</li> </ul>	<ul style="list-style-type: none"> <li>• Liquid Penetrant</li> </ul>

Figure 31. Combustion inspection – key elements

## Hot Gas Path Inspection

The purpose of a hot gas path inspection is to examine those parts exposed to high temperatures from the hot gases discharged from the combustion process. The hot gas path inspection outlined in *Figure 32* includes the full scope of the combustion inspection and, in addition, a detailed inspection of the turbine nozzles, stator shrouds, and turbine buckets. To perform this inspection, the top half of the turbine shell must be removed. Prior to shell removal, proper machine centerline support using mechanical jacks is necessary to assure proper alignment of rotor to stator, obtain accurate half-shell clearances, and prevent twisting of the stator casings. Reference the O&M Manual for unit-specific jacking procedures.

Special inspection procedures apply to specific components in order to ensure that parts meet their intended life. These inspections may include, but are not limited to, dimensional inspections, Fluorescent Penetrant Inspection (FPI), Eddy Current Inspection (ECI), and other forms of non-destructive testing (NDT). The type of inspection required for specific hardware is determined on a part number and operational history basis, and can be obtained from a GE service representative.

Similarly, repair action is taken on the basis of part number, unit operational history, and part condition. Repairs including (but not limited to) strip, chemical clean, HIP (Hot Isostatic Processing), heat treat, and recoat may also be necessary to ensure full parts life. Weld repair will be recommended when necessary, typically as determined by visual inspection and NDT. Failure to perform the required repairs may lead to retirement of the part before its life potential is fulfilled. In contrast, unnecessary repairs are an unneeded expenditure of time and resources. To verify the types of inspection and repair required, contact your GE service representative prior to an outage.

For inspection of the hot gas path (*Figure 31*), all combustion transition pieces and the first-stage turbine nozzle assemblies must be removed. Removal of the second- and third-stage turbine nozzle segment assemblies is optional, depending upon the results of visual observations, clearance measurements, and other required inspections. The buckets can usually be inspected in place. FPI of the bucket vane sections may be required to detect any cracks. In addition, a complete set of internal turbine radial and axial clearances (opening and closing) must be taken during any hot

## Hot Gas Path Inspection

Combustion Inspection Scope—Plus:

Key Hardware	Inspect For	Potential Action
Nozzles (1, 2, 3, 4)	Foreign object damage	Repair/refurbish/replace • Nozzles                      • Buckets – Weld repair                – Strip & recoat – Reposition                – Weld repair – Recoat                      – Blend • Stator shrouds – Weld repair – Blend – Recoat
Buckets (1, 2, 3, 4)	Oxidation/corrosion/erosion	
Stator shrouds	Cracking	
Compressor blading (borescope)	Cooling hole plugging	
	Remaining coating life	
	Nozzle deflection/distortion	
	Abnormal deflection/distortion	
	Abnormal wear	
	Missing hardware	
	Clearance limits	
	Evidence of creep	
Turbine shell	Cracks	Repair or monitor

Criteria	Inspection Methods	Availability of On-Site Spares is Key to Minimizing Downtime
<ul style="list-style-type: none"> <li>O&amp;M Manual</li> <li>GE Field Engineer</li> <li>TILs</li> </ul>	<ul style="list-style-type: none"> <li>Visual</li> <li>Borescope</li> <li>Liquid Penetrant</li> </ul>	

**Figure 32.** Hot gas path inspection – key elements

gas path inspection. Re-assembly must meet clearance diagram requirements to prevent rubs and to maintain unit performance. In addition to combustion inspection requirements, typical hot gas path inspection requirements are:

- Inspect and record condition of first-, second-, and third-stage buckets (and fourth-stage for HA). If it is determined that the turbine buckets should be removed, follow bucket removal and condition recording instructions. Buckets with protective coating should be evaluated for remaining coating life.
- Inspect and record condition of first-, second-, and third-stage nozzles (and fourth-stage for HA).
- Inspect seals and hook fits of turbine nozzles and diaphragms for rubs, erosion, fretting, or thermal deterioration.
- Inspect and record condition of later-stage nozzle diaphragm packings.
- Inspect lab seals and brush seals for any signs of damage.
- Inspect double walled casings mounting surfaces (ledges and wedges) for signs of coating degradation or loss.
- Inspect double walled casing alignment screws and pins for signs of wear or damage.
- Inspect double walled casing seals (dog bone seals) for signs of wear or damage.
- Inspect the exhaust frame mini-case and forward diffuser mini-panel.
- Check discourager seals for rubs, and deterioration of clearance.
- Record the bucket tip clearances.
- Inspect bucket shank seals for clearance, rubs, and deterioration.
- Perform inspections on cutter teeth of tip-shrouded buckets. Consider refurbishment of buckets with worn cutter teeth, particularly if concurrently refurbishing the honeycomb of the corresponding stationary shrouds. Consult your GE service representative to confirm that the bucket under consideration is repairable.
- Check the turbine stationary shrouds for clearance, cracking, erosion, oxidation, rubbing, and build-up of debris.
- Inspect turbine rotor for cracks, object damage, or rubs.
- Check and replace any faulty wheelspace thermocouples.

- Perform borescope inspection of the compressor.
- Visually inspect the turbine shell shroud hooks for signs of cracking.

The first-stage turbine nozzle assembly is exposed to the direct hot gas discharge from the combustion process and is subjected to the highest gas temperatures in the turbine section. Such conditions frequently cause nozzle cracking and oxidation, and in fact, this is expected. The second- and third-stage nozzles are exposed to high gas bending loads, which in combination with the operating temperatures can lead to downstream deflection and closure of critical axial clearances. To a degree, nozzle distress can be tolerated, and criteria have been established for determining when repair is required. More common criteria are described in the O&M Manuals. However, as a general rule, first-stage nozzles will require repair at the hot gas path inspection. The second- and third-stage nozzles may require refurbishment to re-establish the proper axial clearances. Normally, turbine nozzles can be repaired several times, and it is generally repair cost versus replacement cost that dictates the replacement decision.

Coatings play a critical role in protecting the buckets operating at high metal temperatures. They ensure that the full capability of the high strength superalloy is maintained and that the bucket rupture life meets construction expectations. This is particularly true of cooled bucket configurations that operate above 1985°F (1085°C) firing temperature. Significant exposure of the base metal to the environment will accelerate the creep rate and can lead to premature replacement through a combination of increased temperature and stress and a reduction in material strength, as described in *Figure 33*. This degradation process is driven by oxidation of the unprotected base alloy. On early generation uncooled designs, surface degradation due to corrosion or oxidation was considered to be a performance issue and not a factor in bucket life. This is no longer the case at the higher firing temperatures of current generation designs.

Given the importance of coatings, it must be recognized that even the best coatings available will have a finite life, and the condition of the coating will play a major role in determining bucket life. Refurbishment through stripping and recoating is an option for achieving bucket's expected life, but if recoating is selected, it should be done before the coating is breached to expose base metal. Normally, for 7E.03 turbines, this means that recoating



## Oxidation & Bucket Life

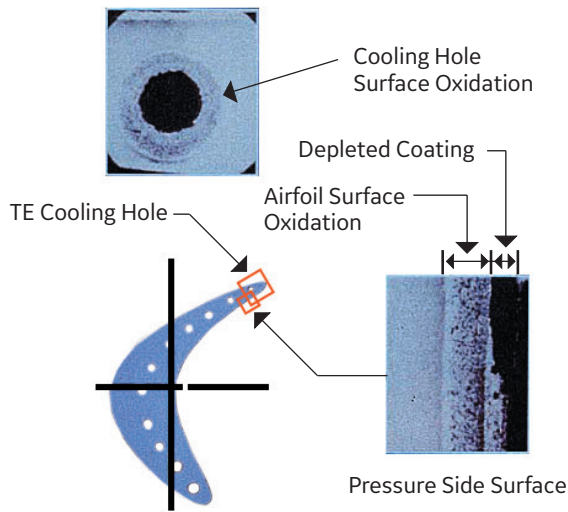

## Base Metal Oxidation



- Increases Stress
  - Reduced Load Carrying Cross Section
- Increases Metal Temperature
  - Surface Roughness Effects
- Decreases Alloy Creep Strength
  - Environmental Effects



## Reduces Bucket Creep Life

**Figure 33.** Stage 1 bucket oxidation and bucket life

will be required at the hot gas path inspection. If recoating is not performed at the hot gas path inspection, the life of the buckets would generally be one additional hot gas path inspection interval, at which point the buckets would be replaced. For F-class gas turbines, recoating of the first stage buckets is recommended at each hot gas path inspection. Visual and borescope examination of the hot gas path parts during the combustion inspections as well as nozzle-deflection measurements will allow the operator to monitor distress patterns and progression. This makes part-life predictions more accurate and allows adequate time to plan for replacement or refurbishment at the time of the hot gas path inspection. It is important to recognize that to avoid extending the hot gas path inspection, the necessary spare parts should be on site prior to taking the unit out of service.

See the O&M Manual for additional recommendations and unit specific guidance.

## Major Inspection

The purpose of the major inspection is to examine all of the internal rotating and stationary components from the inlet of the machine through the exhaust. A major inspection should be scheduled in accordance with the recommendations in the owner's O&M Manual or as modified by the results of previous borescope and hot gas path inspections. The work scope shown in *Figure 34* involves inspection of all of the major flange-to-flange components

of the gas turbine, which are subject to deterioration during normal turbine operation. This inspection includes previous elements of the combustion and hot gas path inspections, and requires laying open the complete flange-to-flange gas turbine to the horizontal joints, as shown in *Figure 29*.

Removal of all of the upper casings allows access to the compressor rotor and stationary compressor blading, as well as to the bearing assemblies. Prior to removing casings, shells, and frames, the unit must be properly supported. Proper centerline support using mechanical jacks and jacking sequence procedures are necessary to assure proper alignment of rotor to stator, obtain accurate half shell clearances, and to prevent twisting of the casings while on the half shell. Reference the O&M Manual for unit-specific jacking procedures. In addition to combustion and hot gas path inspection requirements, typical major inspection requirements are:

- Check all radial and axial clearances against their original values (opening and closing).
- Inspect all casings, shells, and frames/diffusers for cracks and erosion.
- Inspect compressor inlet and compressor flow-path for fouling, erosion, corrosion, and leakage.
- Check rotor and stator compressor blades for tip clearance, rubs, object damage, corrosion pitting, and cracking.

- Remove turbine buckets and perform a nondestructive check of buckets and wheel dovetails. Wheel dovetail fillets, pressure faces, edges, and intersecting features must be closely examined for conditions of wear, galling, cracking, or fretting.
- Inspect unit rotor for heavy corrosion, cracks, object damage, or rubs.
- Inspect bearing liners and seals for clearance and wear.
- Visually inspect compressor and compressor discharge case hooks for signs of wear.
- Visually inspect compressor discharge case inner barrel.
- Inspect exhaust frame flex seals, L-seals, and horizontal joint gaskets for any signs of wear or damage. Inspect steam gland seals for wear and oxidation.
- Inspect lab seals and brush seals for any signs of damage.

- Inspect double walled casings mounting surfaces (ledges and wedges) for signs of coating degradation or loss.
- Inspect double walled casing alignment screws and pins for signs of wear or damage.
- Inspect double walled casing seals (dog bone seals) for signs of wear or damage.
- Inspect the exhaust frame mini-case and forward diffuser mini-panel.
- Check torque values for steam gland bolts and re-torque to full values.
- Check alignment – gas turbine to generator/gas turbine to accessory gear.
- Inspect casings for signs of casing flange slippage.

Comprehensive inspection and maintenance guidelines have been developed by GE and are provided in the O&M Manual to assist users in performing each of the inspections previously described.

## Major Inspection

Hot Gas Path Inspection Scope—Plus:

Key Hardware	Inspect For	Potential Action
Compressor blading	Foreign object damage	Repair/refurbishment/replace
Unit rotor	Oxidation/corrosion/erosion	• Bearings/seals
Journals and seal surfaces	Cracking	- Clean
Bearing seals	Leaks	- Assess oil condition
Exhaust system	Abnormal wear	- Re-babbitt
	Missing hardware	• Compressor blades
	Clearance limits	- Clean
	Coating wear	- Blend
	Fretting	• Exhaust system
		- Weld repair
		- Replace flex seals/L-seals
Compressor and compressor discharge case hooks	Wear	Repair
All cases – exterior and interior	Cracks	Repair or monitor
Cases – Exterior	Slippage	Casing alignment

Criteria	Inspection Methods
<ul style="list-style-type: none"> <li>• O&amp;M Manual</li> <li>• GE Field Engineer</li> <li>• TILs</li> </ul>	<ul style="list-style-type: none"> <li>• Visual</li> <li>• Borescope</li> <li>• Liquid Penetrant</li> <li>• Ultrasonics</li> </ul>

Figure 34. Gas turbine major inspection – key elements



## Parts Planning

Prior to a scheduled disassembly inspection, adequate spares should be on-site. Lack of adequate on-site spares can have a major effect on plant availability. For example, a planned outage such as a combustion inspection, which should only take two to five days, could take weeks if adequate spares are not on-site. GE will provide recommendations regarding the types and quantities of spare parts needed; however, it is up to the owner to purchase these spare parts on a planned basis allowing adequate lead times.

Early identification of spare parts requirements ensures their availability at the time the planned inspections are performed. Refer to the Reference Drawing Manual provided as part of the comprehensive set of O&M Manuals to aid in identification and ordering of gas turbine parts.

Additional benefits available from the renewal parts catalog data system are the capability to prepare recommended spare parts lists for the combustion, hot gas path and major inspections as well as capital and operational spares.

Estimated repair and replacement intervals for some of the major components are shown in *Appendix D*. These tables assume that operation, inspections, and repairs of the unit have been done in accordance with all of the manufacturer's specifications and instructions.

The actual repair and replacement intervals for any particular gas turbine should be based on the user's operating procedures, experience, maintenance practices, and repair practices. The maintenance factors previously described can have a major effect on both the component repair interval and service life. For this reason, the intervals given in *Appendix D* should only be used as guidelines and not certainties for long range parts planning. Owners may want to include contingencies in their parts planning.

The estimated repair and replacement interval values reflect current production hardware (the typical case) with design improvements such as advanced coatings and cooling technology. With earlier production hardware, some of these lives may not be achievable. Operating factors and experience gained during the course of recommended inspection and maintenance procedures will be a more accurate predictor of the actual intervals.

The estimated repair and replacement intervals are based on the recommended inspection intervals shown in *Figure 36*. For certain models, technology upgrades are available that extend the maintenance inspection intervals. The application of inspection (or repair) intervals other than those shown in *Figure 36* can result in different replacement intervals than those shown in *Appendix D*. See your GE service representative for details on a specific system.

It should be recognized that, in some cases, the service life of a component is reached when it is no longer economical to repair any deterioration as opposed to replacing at a fixed interval. This is illustrated in *Figure 35* for a first stage nozzle, where repairs continue until either the nozzle cannot be restored to minimum acceptance standards or the repair cost exceeds or approaches the replacement cost. In other cases, such as first-stage buckets, repair options are limited by factors such as irreversible material damage. In both cases, users should follow GE recommendations regarding replacement or repair of these components.

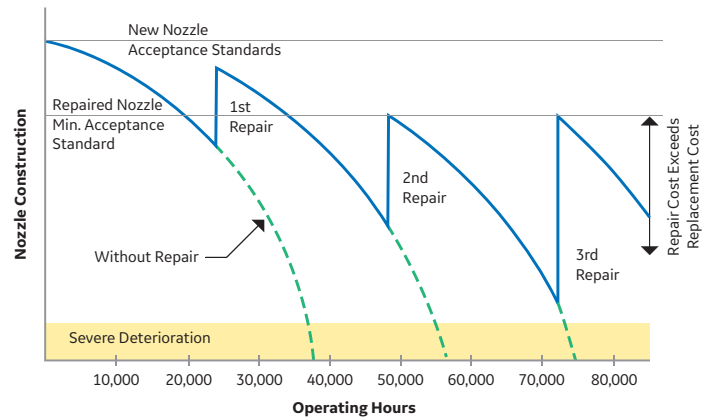

**Figure 35.** First-stage nozzle repair program: natural gas fired – continuous dry – base load

It should also be recognized that the life consumption of any one individual part within a parts set can have variations. This may lead to a certain percentage of “fallout,” or scrap, of parts being repaired. Those parts that fallout during the repair process will need to be replaced by new parts. Parts fallout will vary based on the unit operating environment history, the specific part design, and the current repair technology.

## Inspection Intervals

In the absence of operating experience and resulting part conditions, *Figure 36* lists the recommended visual, combustion, hot gas path and major inspection intervals for current production GE turbines operating under typical conditions of natural gas fuel, base load, and no water/steam injection. These recommended intervals represent factored hours or starts calculated using maintenance factors to account for application specific operating conditions. Initially, recommended intervals are based on the expected operation of a turbine at installation, but this should be reviewed and adjusted as operating and maintenance data are accumulated. While reductions in the recommended intervals will result from the factors described previously or unfavorable operating experience, increases in the recommended intervals may also be considered where operating experience has been favorable.

The condition of the combustion and hot gas path parts provides a basis for customizing a program for inspection and maintenance. The condition of the compressor and bearing assemblies is the key driver in planning a major inspection. Historical operation and machine conditions can be used to tailor maintenance programs such as site specific repair and inspection criteria to specific sites/machines. GE leverages these principles and accumulated site and fleet experience in a “Condition Based Maintenance” program as the basis for maintenance of units under Contractual Service Agreements. This experience was accumulated on units that operate with GE approved repairs, field services, monitoring, and full compliance to GE’s technical recommendations.

GE can assist operators in determining the appropriate maintenance intervals for their particular application. Equations have been developed that account for the factors described earlier and can be used to determine application-specific combustion, hot gas path, and major inspection intervals.

### Borescope Inspection Interval

In addition to the planned maintenance intervals, which undertake scheduled inspections or component repairs or replacements, borescope inspections should be conducted to identify any additional actions, as discussed in the sections “Gas Turbine

Configuration Maintenance Features.” Such inspections may identify additional areas to be addressed at a future scheduled maintenance outage, assist with parts or resource planning, or indicate the need to change the timing of a future outage. The BI should use all the available access points to verify the condition of the internal hardware. As much of the Major Inspection workscope as possible should be done using this visual inspection without disassembly. Refer to *Figure 3* for standard recommended BI frequency. Specific concerns may warrant subsequent BIs in order to operate the unit to the next scheduled outage without teardown.

### ABC Inspections For Annular/Silo Fleet

There are three types of scheduled inspections for all gas turbines in the GE Annular/Silo fleet; Type A Visual Inspection, Type B Visual Inspection, and Type C Major Inspection. The scope of these inspections is based on the design and fleet experience of the gas turbine types to facilitate a reliable operation and optimized usage of the assembled parts. An overview of the different inspection’s scope is given in *Figure 37* but may differ due to series/rating specific configurations. *Figure 38* lists the recommended visual, combustion, hot gas path and major inspection intervals for current production GE Annular/Silo turbines operating under typical conditions of natural gas fuel, base load, and no water/steam injection.

- **Type A Visual Inspection** – Borescope and visual inspection of GE Gas Turbine and Auxiliary System without gas turbine opening.
- **Type B Visual Inspection** – Scope of A type inspection including functional checks and re-adjustments
- **Type C Major Inspection** – Opening and inspection of the gas turbine including maintenance depending on recommended repair and replacement scope. Functional checks and re-adjustment

Type of Inspection	Type of hours/starts	Hours/Starts					
		6B		7E	9E		
		6B.03	7E.03 <sup>(6)</sup>	9E.03 <sup>(7)</sup>	9E.04 <sup>(10)</sup>		
Combustion (Non-DLN)	Factored	12000/600 <sup>(2)(5)</sup>	8000/900 <sup>(2)(5)(11)</sup>	8000/900 <sup>(2)(5)(11)</sup>	32000/900 <sup>(2)(11)</sup>		
Combustion (DLN)	Factored	12000/450 <sup>(5)</sup>	12000/450 <sup>(5)(11)</sup>	12000/450 <sup>(5)(11)</sup>	32000/900 <sup>(11)</sup>		
Hot Gas Path	Factored	32000/1200 <sup>(13)</sup>	32000/1200 <sup>(13)</sup>	32000/900 <sup>(12)</sup>	32000/900		
Major	Factored	64000/2400 <sup>(5)</sup>	64000/2400 <sup>(5)</sup>	64000/2400 <sup>(5)</sup>	64000/1800 <sup>(5)</sup>		

Type of Inspection	Type of hours/starts	Hours/Starts					
		6F		7F			
		6F.01	6F.03	7F.03 <sup>(11)</sup>			
Combustion (Non-DLN)	Factored		8000/400				
Combustion (DLN)	Factored	32000/900	24000/900 <sup>(5)</sup>	24000/900			
Hot Gas Path	Factored	32000/450**	24000/900	24000/900			
Major	Factored	64000/1800	48000/2400	48000/2400			

Type of Inspection	Type of hours/starts	Hours/Starts					
		7F			9F		
		7F.04	7FB.04	7F.05	9F.03	9F.04	9F.05
Combustion (Non-DLN)	Factored						
Combustion (DLN)	Factored	32000/950 <sup>(5)</sup>	32000/950 <sup>(5)</sup>	24000/900	24000/900	32000/1200	12000/450
Hot Gas Path	Factored	32000/1250	32000/1250	24000/900	24000/900	32000/1200	24000/900
Major	Factored	64000/2500	64000/2500	48000/2400	48000/2400	64000/2400	48000/2400

Type of Inspection	Type of hours/starts	Hours/Starts					
		7HA		9HA			
		7HA.01 <sup>(8)</sup>	7HA.02 <sup>(8)</sup>	9HA.01 <sup>(8)</sup>	9HA.02 <sup>(8)</sup>		
Combustion (DLN)	Factored	25000/900	25000/720	25000/900 <sup>(9)</sup>	25000/720		
Hot Gas Path	Factored	25000/900	25000/720	25000/900	25000/720		
Major	Factored	50000/1800	50000/1440	50000/1800	50000/1440		

Factors that can reduce maintenance intervals:

- Fuel
- Load setting
- Steam/water injection
- Peak load firing operation
- Trips
- Start cycle
- Hardware design
- Off-frequency operation

1. Units with Lean Head End liners have a 400-starts combustion inspection interval.
2. Multiple Non-DLN configurations exist (Standard, MNQC, IGCC). The typical case is shown; however, different quoting limits may exist on a machine and hardware basis. Contact a GE service representative for further information.
3. Combustion inspection without transition piece removal. Combustion inspection with transition pieces removal to be performed every 2 combustion inspection intervals.
4. Hot gas path inspection for factored hours eliminated on units that operate on natural gas fuel without steam or water injection.
5. Precedent technology may have shorter inspection intervals. Upgraded technology (Extendor\*, PIP, DLN 2.6+, etc) may have longer inspection intervals. Contact a GE service representative for further information.

6. Also applicable to 7121(EA) models.
7. Applicable to non-AGP units only.
8. Intervals assume Base Tfire
9. CI = 450 Starts for DLN2.6+
10. Applicable to New Units of 9E.04 and Flange-to-Flange Upgrades
11. Non-DLN Standard, DLN, and DLN with AFS configurations exist. Contact a GE service representative for further information.
12. Applies to AGP (Advanced Gas Path) hardware only. Older models may have shorter intervals.
13. Applies to PIP (Performance Improvement Package) hardware only. Older models may have shorter intervals.

\*Trademark of General Electric Company

\*\*Applicable to S1B only, all other HGP hardware is 900FFS

**Note:**

Baseline inspection intervals reflect current production hardware, unless otherwise noted, and operation in accordance with manufacturer specifications. They represent initial recommended intervals in the absence of operating and condition experience. For Repair/Replace intervals see *Appendix D*. Rotor maintenance intervals are calculated independently.

**Figure 36.** Baseline recommended inspection intervals: base load – natural gas fuel – dry

<b>System</b>	<b>Type A Visual Inspection</b>	<b>Type B Visual Inspection</b>	<b>Type C Major Inspection</b>
<b>Gas Turbine</b>			
Air Inlet System	Visual Inspection	Visual Inspection	Visual Inspection/Cleaning/Maintenance
Bleed Valve/Variable Guide Vane System		Functional Test	Functional Test
GT Compressor	Visual/Borescope Inspection	Visual/Borescope Inspection	Visual Inspection/Cleaning/Repair and Replacement
GT Combustor	Visual/Borescope Inspection	Visual/Borescope Inspection/ Functional Test	Visual Inspection/Cleaning/Functional Test/Repair and Replacement
GT Turbine	Visual/Borescope Inspection	Visual/Borescope Inspection	Visual Inspection/Cleaning/Maintenance/Repair and Replacement
GT Rotor	Alignment Check	Alignment Check	Visual Inspection/RLM/Alignment Check and Correction
Exhaust Gas System	Visual Inspection	Visual Inspection	Visual Inspection/Maintenance
GT Cooling Air Systems	Visual Inspection	Visual Inspection/Functional Test	Visual Inspection/Functional Test, Leakage Check
<b>Controls, Protection and Monitoring</b>			
GT Control System		Functional Test	Functional Test
Protection/Monitoring		Functional Test	Functional Test
Enclosure/Fire Fighting/ Gas Detection System	Visual Inspection	Visual Inspection/Functional Test	Visual Inspection/Functional Test
Checks Prior to Re-start	General Visual Inspection	General Visual Inspection/ Functional Test	General Visual Inspection/Functional Test
<b>Auxiliary Systems</b>			
Lube Oil System	Leakage Inspection	Leakage Inspection/Functional Test	Leakage Inspection/Functional Test
Cooling Water	Leakage Inspection	Leakage Inspection	Leakage Inspection/Functional Test
Fuel Systems	Leakage Inspection	Leakage Inspection/Functional Test	Leakage Inspection/Functional Test
Compressor Wash/Drain Equipment			Functional Test
Control/Sealing Air System	Leakage Inspection	Leakage Inspection	Leakage Inspection/Functional Test
AC/DC Supply			Visual Inspection/Functional Test
Batteries	Visual Inspection	Visual Inspection	Visual Inspection/Functional Test

**Figure 37.** ABC Inspections

**Baseline Recommended Inspection Intervals: Base Load – Natural Gas Fuel – Dry for GE Annular/Silo Fleet**

Series/Rating	GT11N2			GT13E2	
	Baseline EV/SB	Upgrade XL	Upgrade M	Baseline MXL	Upgrade MXL2
Counter Type	Linear	Linear	Linear Extended	Linear Extended	Linear Extended
Inspection Type					
1st A	6'000 EOH	8'000 EOH	12'000 EOH	9'000 EOH	12'000 EOH
			12'000 WOH	9'000 WOH	12'000 WOH
			300 WCE	300 WCE	400 WCE
B	12'000 EOH	16'000 EOH	24'000 EOH	18'000 EOH	24'000 EOH
			24'000 WOH	18'000 WOH	24'000 WOH
			600 WCE	600 WCE	800 WCE
2nd A**	18'000 EOH	24'000 EOH	36'000 EOH	27'000 EOH	36'000 EOH
			36'000 WOH	27'000 WOH	36'000 WOH
			900 WCE	900 WCE	1'200 WCE
C	24'000 EOH	32'000 EOH	48'000 EOH	36'000 EOH	48'000 EOH
			48'000 WOH	36'000 WOH	48'000 WOH
			1'200 WCE	1'200 WCE	1'600 WCE

Series/Rating	GT24			GT 26				
	Baseline A*, AB, B	Baseline (2006) Upgrade MXL	Baseline (2011) Upgrade MXL2	Baseline AB*, B	Baseline (2006)	Upgrade APP	Baseline MXL2	Upgrade MXL2
Counter Type	Linear*/ Elliptical	Linear Extended	Linear Extended	Linear*/ Elliptical	Elliptical*/ Linear Extended	Linear Extended	Linear Extended	Box
Inspection Type								
1st A	6'000 EOH	8'000 EOH	9'000 EOH	6'000 EOH	7'000 EOH	9'000 EOH	9'000 EOH	
		7'000 WOH	8'000 WOH		6'000 WOH	8'000 WOH	8'000 WOH	8'000 WOH
		300 WCE	300 WCE		300 WCE	300 WCE	300 WCE	300 WCE
B	12'000 EOH	16'000 EOH	18'000 EOH	12'000 EOH	14'000 EOH	18'000 EOH	18'000 EOH	
		14'000 WOH	16'000 WOH		12'000 WOH	16'000 WOH	16'000 WOH	16'000 WOH
		600 WCE	600 WCE		600 WCE	600 WCE	600 WCE	600 WCE
2nd A**	18'000 EOH	24'000 EOH	27'000 EOH	18'000 EOH	21'000 EOH	27'000 EOH	27'000 EOH	
		21'000 WOH	24'000 WOH		18'000 WOH	24'000 WOH	24'000 WOH	24'000 WOH
		900 WCE	900 WCE		900 WCE	900 WCE	900 WCE	900 WCE
C	24'000 EOH	32'000 EOH	36'000 EOH	24'000 EOH	28'000 EOH	36'000 EOH	36'000 EOH	
		28'000 WOH	32'000 WOH		24'000 WOH	32'000 WOH	32'000 WOH	32'000 WOH
		1'200 WCE	1'200 WCE		1'200 WCE	1'200 WCE	1'200 WCE	1'200 WCE

(\*) Project specific counter type

(\*\*) Based on fleet experience and project specific hardware a reduced number of inspections may apply, e.g. "A-B-C". Not applicable to HE

EOH – Equivalent Operating Hours  
 WOH – Weighted Operating Hours  
 WCE – Weighted Cyclic Events

**Figure 38.** Annular/Silo Fleet Inspection Intervals

## Combustion Inspection Interval

Equations have been developed that account for the earlier mentioned factors affecting combustion maintenance intervals. These equations represent a generic set of maintenance factors that provide guidance on maintenance planning. As such, these equations do not represent the specific capability of any given combustion system. For combustion parts, the baseline operating conditions that result in a maintenance factor of one are normal fired startup and shutdown (no trip) to base load on natural gas fuel without steam or water injection.

An hours-based combustion maintenance factor can be determined from the equations given in *Figure 39* as the ratio of factored hours to actual operating hours. Factored hours considers the effects of fuel type, load setting, and steam/water injection. Maintenance factors greater than one reduce recommended combustion inspection intervals from those shown in *Figure 36* representing baseline operating conditions. To obtain a recommended inspection interval for a specific application, the maintenance factor is divided into the recommended baseline inspection interval.

A starts-based combustion maintenance factor can be determined from the equations given in *Figure 40* and considers the effect of fuel type, load setting, peaking-fast starts, trips, and steam/water injection. An application-specific recommended inspection interval can be determined from the baseline inspection interval in *Figure 36* and the maintenance factor from *Figure 40*. *Appendix B* shows six example maintenance factor calculations using the above hours and starts maintenance factor equations.

Syngas units require unit-specific intervals to account for unit-specific fuel constituents and water/steam injection schedules. As such, the combustion inspection interval equations may not apply to those units.

### Hours-Based Combustion Inspection

$$\text{Maintenance Interval} = \frac{\text{Baseline CI (Figure 36)}}{\text{Maintenance Factor}}$$

$$\text{Maintenance Factor} = \frac{\text{Factored Hours}}{\text{Actual Hours}}$$

$$\text{Factored Hours} = \sum (K_i \cdot A_{f_i} \cdot A_{p_i} \cdot t_i), i = 1 \text{ to } n \text{ in Operating Modes}$$

$$\text{Actual Hours} = \sum (t_i), i = 1 \text{ to } n \text{ in Operating Modes}$$

Where:

$i$  = Discrete Operating mode (or Operating Practice of Time Interval)

$t_i$  = Operating hours at Load in a Given Operating mode

$A_{p_i}$  = Load Severity factor

$A_p$  = 1.0 up to Base Load

$A_p$  = For Peak Load Factor See *Figure 10*

$A_{f_i}$  = Fuel Severity Factor

$A_f$  = 1.0 for Natural Gas Fuel<sup>(1)</sup>

$A_f$  = 1.5 for Distillate Fuel (Non-DLN)

$A_f$  = 2.5 for Distillate Fuel (DLN E/F-Class)

$A_f$  = 2.5 for Crude (Non-DLN)

$A_f$  = 3.5 for Residual Fuel (Non-DLN)

$K_i$  = Water/Steam Injection Severity Factor  
(% Steam Referenced to Compressor Inlet Air Flow,  
 $w/f$  = Water to Fuel Ratio)

$K$  =  $\text{Max}(1.0, \exp(0.34(\% \text{Steam} - 2.00\%)))$   
for Steam, Dry Control Curve

$K$  =  $\text{Max}(1.0, \exp(0.34(\% \text{Steam} - 1.00\%)))$   
for Steam, Wet Control Curve

$K$  =  $\text{Max}(1.0, \exp(1.80(w/f - 0.80)))$   
for Water, Dry Control Curve

$K$  =  $\text{Max}(1.0, \exp(1.80(w/f - 0.40)))$   
for Water, Wet Control Curve

(1)  $A_f$  = 10 for DLN 1/DLN 1+ extended lean-lean (excluding Nimonic 263 material components where  $A_f$  = 4).  
 $A_f$  = 10 for DLN 2.0/DLN 2+ extended piloted premixed operation.

### Starts-Based Combustion Inspection

$$\text{Maintenance Interval} = \frac{\text{Baseline CI (Figure 36)}}{\text{Maintenance Factor}}$$

$$\text{Maintenance Factor} = \frac{\text{Factored Starts}}{\text{Actual Starts}}$$

$$\text{Factored Starts} = \sum (K_i \cdot A_{f_i} \cdot A_{t_i} \cdot A_{p_i} \cdot A_{s_i} \cdot N_i), i = 1 \text{ to } n \text{ Start/Stop Cycles}$$

$$\text{Actual Starts} = \sum (N_i), i = 1 \text{ to } n \text{ in Start/Stop Cycles}$$

Where:

$i$  = Discrete Start/Stop Cycle (or Operating Practice)

$N_i$  = Start/Stop Cycles in a Given Operating Mode

$A_{s_i}$  = Start Type Severity Factor

$A_s$  = 1.0 for Normal Start

$A_s$  = For Peaking-Fast Start See *Figure 13*

$A_{p_i}$  = Load Severity Factor

$A_p$  = 1.0 up to Base Load

$A_p$  =  $\exp(0.009 \times \text{Peak Firing Temp Adder in } ^\circ\text{F})$   
for Peak Load

$A_{t_i}$  = Trip Severity Factor

$A_t$  =  $0.5 + \exp(0.0125 \cdot \% \text{Load})$  for Trip

$A_t$  = 1 for No Trip

$A_{f_i}$  = Fuel Severity Factor

$A_f$  = 1.0 for Natural Gas Fuel

$A_f$  = 1.25 for Distillate Fuel (Non-DLN)

$A_f$  = 1.5 for Distillate Fuel (DLN E/F-Class)

$A_f$  = 2.0 for Crude (Non-DLN)

$A_f$  = 3.0 for Residual Fuel (Non-DLN)

$K_i$  = Water/Steam Injection Severity Factor  
(% Steam Referenced to Compressor Inlet Air Flow,  
 $w/f$  = Water to Fuel Ratio)

$K$  =  $\text{Max}(1.0, \exp(0.34(\% \text{Steam} - 1.00\%)))$   
for Steam, Dry Control Curve

$K$  =  $\text{Max}(1.0, \exp(0.34(\% \text{Steam} - 0.50\%)))$   
for Steam, Wet Control Curve

$K$  =  $\text{Max}(1.0, \exp(1.80(w/f - 0.40)))$   
for Water, Dry Control Curve

$K$  =  $\text{Max}(1.0, \exp(1.80(w/f - 0.20)))$   
for Water, Wet Control Curve

**Figure 39.** Combustion inspection hours-based maintenance factors

**Figure 40.** Combustion inspection starts-based maintenance factors

## Hot Gas Path Inspection Interval

The hours-based hot gas path criterion is determined from the equations given in *Figure 41*. With these equations, a maintenance factor is determined that is the ratio of factored operating hours and actual operating hours. The factored hours consider the specifics of the duty cycle relating to fuel type, load setting and steam or water injection. Maintenance factors greater than one reduce the hot gas path inspection interval from the baseline (typically 24,000 hour) case. To determine the application specific maintenance interval, the maintenance factor is divided into the baseline hot gas path inspection interval, as shown in *Figure 41*.

### Hours-Based HGP Inspection

$$\text{Maintenance Interval (Hours)} = \frac{\text{Baseline HGPI (Figure 36)}}{\text{Maintenance Factor}}$$

$$\text{Maintenance Factor} = \frac{\text{Factored Hours}}{\text{Actual Hours}}$$

$$\text{Factored Hours} = \sum_{i=1}^n (S_i \cdot A_{f_i} \cdot A_{p_i} \cdot t_i)$$

$$\text{Actual Hours} = \sum_{i=1}^n (t_i)$$

$i$  = 1 to  $n$  discrete operating modes (or operating practices of time interval)

$t_i$  = Fired hours in a given operating mode

$A_{p_i}$  = Load severity factor for given operating mode

$A_p$  = 1.0 up to base load

$A_p$  = For peak load factor see *Figure 10*.

$A_{f_i}$  = Fuel severity factor for given operating mode

$A_f$  = 1.0 for natural gas

$A_f$  = 1.5 for distillate

(=1.0 when  $A_p > 1$ , at minimum  $A_f \cdot A_p = 1.5$ )

$A_f$  = 2 to 3 for crude\*

$A_f$  = 3 to 4 for residual\*

$S_i$  = Water/steam injection severity factor =  $K_i + (M_i \cdot I_i)^*$

$I$  = Percent water/steam injection referenced to compressor inlet air flow

M&K = Water/steam injection constants

\* N/A for HA-class

M	K	Control	Water/Steam Inj.	S2N/S3N Material
0	1	Dry	<2.2%	All
0	1	Dry	>2.2%	Non-FSX-414
0.18	0.6	Dry	>2.2%	FSX-414
0.18	1	Wet	>0%	Non-FSX-414
0.55	1	Wet	>0%	FSX-414

**Figure 41.** Hot gas path maintenance interval: hours-based criterion

The starts-based hot gas path criterion is determined from the equations given in *Figure 42*. With the advent of non-synchronous generation, and increased interest on gas turbines to power soft and industrial grids, power generating units are more often considered to contain large load steps, defined as more than +/- 20% of GT rated load change in 10 seconds or less.

As previously described, the limiting criterion (hours or starts) determines the maintenance interval. Examples of these equations are in *Appendix A*.

### Starts-Based HGP Inspection

$$\text{Maintenance Interval (Starts)} = \frac{S}{\text{Maintenance Factor}}$$

Where:

$$\text{Maintenance Factor} = \frac{\text{Factored Starts}}{\text{Actual Starts}}$$

$$\text{Factored Starts} = 0.5N_A + N_B + 1.3N_P + P_s F + \sum_{i=1}^n (a_{T_i} - 1) T_i + \sum_{i=1}^k (a_{L_i} - 1) L_i$$

$$\text{Actual Starts} = (N_A + N_B + N_P)$$

$S$  = Baseline Starts-Based Maintenance Interval (*Figure 36*)

$N_A$  = Annual Number of Part Load Start/Stop Cycles (<60% Load)

$N_B$  = Annual Number of Base Load Start/Stop Cycles

$N_P$  = Annual Number of Peak Load Start/Stop Cycles (>100% Load)

$P_s$  = Peaking-Fast Start Factor (See *Figure 13*)

$F$  = Annual Number of Peaking-Fast Starts

$T$  = Annual Number of Trips

$a_T$  = Trip Severity Factor =  $f(\text{Load})$  (See *Figure 19*)

$n$  = Number of Trip Categories (i.e. Full Load, Part Load, etc.)

$L$  = Annual Number of Load Steps  $\geq 20\%$

$a_L$  =  $\text{Exp}(0.0137 \times \% \text{ Load Step})$

$k$  = Number of Load Step Levels

**Figure 42.** Hot gas path maintenance interval: starts-based criterion



## GE Annular/Silo Fleet Inspection Intervals

Inspection intervals are primarily based on the hot gas path lifetime (i.e. turbine and combustor) and determine the intervals of visual and major inspections, whereas part repair or replacement is not expected to be necessary during visual inspections.

### Counting Methods and Parameters

- Linear (initial BE-class)  $EOH = (S*V + TPE*W + OH*X) * Z$
- Elliptical (initial F-class)  $EOH = \sqrt{[(V*S)^2 + (A*OH)^2]*Z}$
- Extended Linear (BEF-class)  $EOH = WOH + 10x WCE$   
(later upgrades new/service)  $WOH = OH * X * Z / WCE = CE * V * Z$
- Box  
(future, latest F-upgrade)  $WOH = OH * X * Z / WCE = CE * V * Z$

EOH	Equivalent Operating Hours
WOH	Weighted Operating Hours
OH	Operating hours
WCE	Weighted Cyclic Events
S	Starts
V, X, W, A	Penalty factors
Z	Fuel factor
TPE, CE	Protective/cyclic events

Fuel and penalty factors are GT Type and upgrade specific

**Figure 43.** Legacy Alstom Inspection Interval Counting Methods

## Rotor Inspection Interval

Like hot gas path components, the unit rotor has a maintenance interval involving removal, disassembly, and inspection. This interval indicates the serviceable life of the rotor and is generally considered to be the teardown inspection and repair/replacement interval for the rotor. The disassembly inspection is usually concurrent with a hot gas path or major inspection; however, it should be noted that the maintenance factors for rotor maintenance intervals are distinct from those of combustion and hot gas path components. As such, the calculation of consumed life on the rotor may vary from that of combustion and hot gas path components. Customers should contact GE 1 to 2 years prior to their rotor reaching the end of its serviceable life for technical advisement.

Figure 44 describes the procedure to determine the hours-based maintenance criterion. Peak load operation is the primary hour maintenance factor for all rotors and will act to increase the hours-based maintenance factor and to reduce the rotor maintenance

interval. For B/E-class units time on turning gear also affects rotor life. For HA, rotor maintenance factor can be reduced via the use of technology, such as evaporative coolers.

The starts-based rotor maintenance interval is determined from the equations given in Figure 45. Adjustments to the rotor maintenance interval are determined from rotor-based operating factors as described previously. In the calculation for the starts-based rotor maintenance interval, equivalent starts are determined for cold, warm, and hot starts over a defined time period by multiplying the appropriate cold, warm, and hot start operating factors by the number of cold, warm, and hot starts respectively. Additionally, equivalent starts for rapid/forced/crank cool downs are added. The total equivalent starts are divided by the actual number of starts to yield the maintenance factor. The rotor starts-based maintenance interval is determined by dividing the baseline rotor maintenance interval starts number by the calculated maintenance factor. The baseline rotor maintenance interval is also the maximum

### Hours-Based Rotor Inspection

$$\text{Maintenance Interval (Hours)} = \frac{R}{\text{Maintenance Factor}}$$

$$MF = \frac{\text{Factored Hours}}{\text{Actual Hours}} = \frac{H + 2P^{(1)}}{H + P} \quad \text{MF for B/E-class} = \frac{H + 2P + 2T_G^{(2)}}{H + P}$$

H = Non-peak load operating hours

P = Peak load operating hours

T<sub>G</sub> = Hours on turning gear

R = Baseline rotor inspection interval

Machine	R <sup>(3)</sup>
FA.05 & HA Class	Refer to unit specific documentation.
F-class	144,000
B & E Class	200,000

(1) Maintenance factor equation to be used unless otherwise notified in unit-specific documentation.

(2) To diminish potential turning gear impact, major inspections must include a thorough visual and dimensional examination of the hot gas path turbine rotor dovetails for signs of wearing, galling, fretting, or cracking. If no distress is found during inspection or after repairs are performed to the dovetails, time on turning gear may be omitted from the hours-based maintenance factor.

(3) Baseline rotor inspection intervals to be used unless otherwise notified in unit-specific documentation.

**Figure 44.** Rotor maintenance interval: hours-based criterion

interval, since calculated maintenance factors less than one are not considered.

When the rotor reaches the earlier of the inspection intervals described in *Figures 44 and 45*, a GE Rotor Life Extension shall be completed on the rotor components in both the compressor and turbine. It should be expected that some rotor components will either have reached the end of their serviceable life or will have a minimal amount of residual life remaining and will require repair or replacement at this inspection point. Depending on the extent of refurbishment and part replacement, subsequent inspections may be required at a reduced interval.

### Starts-Based Rotor Inspection

$$\text{Maintenance Interval (Starts)} = \frac{5,000^{(1)}}{\text{Maintenance Factor}}$$

$$\text{Maintenance Factor} = \frac{\text{Factored Starts}}{\text{Actual Starts}}$$

For units with published start factors:

$$\text{Maintenance Factor} = \frac{(F_{h1} \cdot N_{h1} + F_{h2} \cdot N_{h2} + F_{w1} \cdot N_{w1} + F_{w2} \cdot N_{w2} + F_c \cdot N_c + F_{FC} \cdot N_{FC})}{(N_{h1} + N_{h2} + N_{w1} + N_{w2} + N_c)}$$

For B/E-class units

$$\text{Maintenance Factor} = \frac{N_s + (2.3 \cdot N_{FC})}{N_s}$$

For all other units additional start factors may apply.

#### Number of Starts

$N_{h1}$  = Number of hot 1 starts

$N_{h2}$  = Number of hot 2 starts

$N_{w1}$  = Number of warm 1 starts

$N_{w2}$  = Number of warm 2 starts

$N_c$  = Number of cold starts

$N_{FC}$  = Number of Rapid/Forced/Crank Cool Shutdowns

$N_s$  = Total number of fired starts

#### Start Factors<sup>(2)</sup>

$F_{h1}$  = Hot 1 start factor (down 0-1 hr)

$F_{h2}$  = Hot 2 start factor (1 hour < downtime ≤ 4 hours)

$F_{w1}$  = Warm 1 start factor (4 hours < downtime ≤ 20 hours)

$F_{w2}$  = Warm 2 start factor (20 hours < downtime ≤ 40 hours)

$F_c$  = Cold start factor (downtime > 40 hours)

$F_{FC}$  = Rapid/Forced/Crank Cooling Shutdown Factor

(1) Baseline rotor inspection interval for B, E, and F class rotors is 5,000 fired starts unless otherwise notified in unit-specific documentation. Refer to unit specific documentation for FA.05 and HA class rotors for baseline starts number.

(2) Start factors for certain F-class units are tabulated in *Figure 21*. For all other machines, consult unit-specific documentation to determine if start factors apply.

## GE Annular/Silo Fleet Welded Rotor Inspection

Rotors are constructed with the intention of achieving four C- inspection intervals. Detailed minimum expected lifetime data in terms of Operating Hours (OH) can be found in *Figure 46*.

GE Annular/Silo Rotors – Creep Life		
GE Annular/Silo – B-Fleet		
	GT Type (all sub-ratings included)	Minimum expected Lifetime of Rotor (OH)
GT8	B	100000
	C	100000
	C2	100000
GT9	B, C, D	200000
GT11	B, C, D, N	130000
GT11	N2	150000
GT13	B, C, D	130000
GE Annular/Silo – E-Fleet		
	GT Type (all sub-ratings included)	Minimum expected Lifetime of Rotor (OH)
GT13	E1	144000
	E2	144000
GE Annular/Silo – F-Fleet		
	GT Type (all sub-ratings included)	Minimum expected Lifetime of Rotor (OH)
GT24	All Ratings	150000
GT26	All Ratings	150000

\* Impact of GT26 HE to be evaluated on a case by case basis

**Figure 46.** Annular/Silo Fleet Rotor Life

Rotor Life-time Monitoring (RLM) programs are recommended to be applied in order to increase project specific rotor lifetime capabilities. As part of RLM inspection, GE recommends performing “RLM Creep” location specific deformation measurements at every C-inspection to enable creep-based life trending for rotor life enhancement. Similarly, GE recommends performing “RLM Cyclic” based inspections based on fired starts & fatigue degradations as can be found in GE Annular/Silo Fleet safety TILs. These safety TILs outline details associated with when to start RLM Cyclic inspections based on fired starts, safety critical inspection fired starts limits, and maximum expected fired starts limits with proper application of RLM cyclic monitoring over the full life of the GT rotor.

**Figure 45.** Rotor maintenance interval: starts-based criterion

## Personnel Planning

It is essential that personnel planning be conducted prior to an outage. It should be understood that a wide range of experience, productivity, and working conditions exist around the world. However, an estimate can be made based upon maintenance inspection labor assumptions, such as the use of a crew of workers with trade skill (but not necessarily direct gas turbine experience), with all needed tools and replacement parts (no repair time) available. These estimated craft labor hours should include controls/accessories and the generator. In addition to the craft labor, additional resources are needed for technical direction, specialized tooling, engineering reports, and site mobilization/demobilization. Inspection frequencies and the amount of downtime varies within the gas turbine fleet due to different duty cycles and the economic need for a unit to be in a state of operational readiness. Contact your local GE service representative for the estimated labor hours and recommended crew size for your specific unit. Depending upon the extent of work to be done during each maintenance task, a cooldown period of 4 to 24 hours may be required before service may be performed. This time can be utilized productively for job move-in, correct tagging and locking equipment out-of-service, and general work preparations. At the conclusion of the maintenance work and systems check out, a turning gear time of two to eight hours is normally allocated prior to starting the unit. This time can be used for job clean-up and preparing for start. Local GE field service representatives are available to help plan maintenance work to reduce downtime and labor costs. This planned approach will outline the replacement parts that may be needed and the projected work scope, showing which tasks can be accomplished in parallel and which tasks must be sequential. Planning techniques can be used to reduce maintenance cost by optimizing lifting equipment schedules and labor requirements. Precise estimates of the outage duration, resource requirements, critical-path scheduling, recommended replacement parts, and costs associated with the inspection of a specific installation may be sourced from the local GE field services office.

## Conclusion

GE heavy-duty gas turbines are constructed to have high availability. To achieve increased gas turbine availability, an owner must understand not only the equipment but also the factors affecting it. This includes the training of operating and maintenance personnel, following the manufacturer's recommendations, regular periodic inspections, and the stocking of spare parts for immediate replacement. The recording and analysis of operating data is also essential to preventative and planned maintenance. A key factor in achieving this goal is a commitment by the owner to provide effective outage management, to follow published maintenance instructions, and to utilize the available service support facilities.

It should be recognized that, while the manufacturer provides general maintenance recommendations, it is the equipment user who controls the maintenance and operation of equipment. Inspection intervals for optimum turbine service are not fixed for every installation but rather are developed based on operation and experience. In addition, through application of a Contractual Service Agreement to a particular turbine, GE can work with a user to establish a maintenance program that may differ from general recommendations but will be consistent with contractual responsibilities.

The level and quality of a rigorous maintenance program have a direct effect on equipment reliability and availability. Therefore, GE provides a knowledge based gas turbine user solution that reduces costs and outage time while improving reliability and profitability.

## References

- Jarvis, G., "Maintenance of Industrial Gas Turbines," GE Gas Turbine State of the Art Engineering Seminar, paper SOA-24-72, June 1972.
- Patterson, J. R., "Heavy-Duty Gas Turbine Maintenance Practices," GE Gas Turbine Reference Library, GER-2498, June 1977.
- Moore, W. J., Patterson, J.R, and Reeves, E.F., "Heavy-Duty Gas Turbine Maintenance Planning and Scheduling," GE Gas Turbine Reference Library, GER-2498; June 1977, GER 2498A, June 1979.
- Carlstrom, L. A., et al., "The Operation and Maintenance of General Electric Gas Turbines," numerous maintenance articles/authors reprinted from Power Engineering magazine, General Electric Publication, GER-3148; December 1978.
- Knorr, R. H., and Reeves, E. F., "Heavy-Duty Gas Turbine Maintenance Practices," GE Gas Turbine Reference Library, GER-3412; October 1983; GER- 3412A, September 1984; and GER-3412B, December 1985.
- Freeman, Alan, "Gas Turbine Advance Maintenance Planning," paper presented at Frontiers of Power, conference, Oklahoma State University, October 1987.
- Hopkins, J. P, and Osswald, R. F., "Evolution of the Design, Maintenance and Availability of a Large Heavy-Duty Gas Turbine," GE Gas Turbine Reference Library, GER-3544, February 1988 (never printed).
- Freeman, M. A., and Walsh, E. J., "Heavy-Duty Gas Turbine Operating and Maintenance Considerations," GE Gas Turbine Reference Library, GER-3620A.
- GEI-41040, "Fuel Gases for Combustion in Heavy-Duty Gas Turbines."
- GEI-41047, "Gas Turbine Liquid Fuel Specifications."
- GEK-101944, "Requirements for Water/Steam Purity in Gas Turbines."
- GER-3419A, "Gas Turbine Inlet Air Treatment."
- GEK-32568, "Lubricating Oil Recommendations for Gas Turbines with Bearing Ambients Above 500°F (260°C)."
- GEK-110483, "Cleanliness Requirements for Power Plant Installation, Commissioning and Maintenance."
- IEEE 762-2006

# Appendix

## A.1) Example 1 – Hot Gas Path Maintenance Interval Calculation

A 7E.03 user has accumulated operating data since the last hot gas path inspection and would like to estimate when the next one should be scheduled. The user is aware from GE publications that the baseline HGP interval is 24,000 hours if operating on natural gas, with no water or steam injection, and at base load. It is also understood that the baseline starts interval is 1200, based on normal startups, no trips, no peaking-fast starts. The actual operation of the unit since the last hot gas path inspection is much different from the baseline case. The unit operates in four different operating modes:

1. The unit runs 3200 hrs/yr in its first operating mode, which is natural gas at base or part load with no steam/water injection.
2. The unit runs 350 hrs/yr in its second operating mode, which is distillate fuel at base or part load with no steam/water injection.
3. The unit runs 120 hrs/yr in its third operating mode, which is natural gas at peak load (+100°F) with no steam/water injection.
4. The unit runs 20 hrs/yr in its fourth operating mode, which is natural gas at base load with 2.4% steam injection on a wet control curve.

The hours-based hot gas path maintenance interval parameters for these four operating modes are summarized below:

		Operating Mode (i)			
		1	2	3	4
Fired hours (hrs/yr)	t	3200	350	120	20
Fuel severity factor	Af	1	1.5	1	1
Load severity factor	Ap	1	1	$[e^{(0.018 \cdot 100)}] = 6$	1
Steam/water injection rate (%)	I	0	0	0	2.4

For this particular unit, the second- and third-stage nozzles are FSX-414 material. From Figure 41, at a steam injection rate of 2.4% on a wet control curve,

$$M_4 = 0.55, K_4 = 1$$

The steam severity factor for mode 4 is therefore,

$$= S_4 = K_4 + (M_4 \cdot I_4) = 1 + (0.55 \cdot 2.4) = 2.3$$

At a steam injection rate of 0%,

$$M = 0, K = 1$$

Therefore, the steam severity factor for modes 1, 2, and 3 are

$$= S_1 = S_2 = S_3 = K + (M \cdot I) = 1$$

From the hours-based criteria, the maintenance factor is determined from Figure 39.

$$MF = \frac{\sum_{i=1}^n (S_i \cdot Af_i \cdot Ap_i \cdot t_i)}{\sum_{i=1}^n (t_i)}$$

$$= \frac{(1 \cdot 1 \cdot 1 \cdot 3200) + (1 \cdot 1.5 \cdot 1 \cdot 350) + (1 \cdot 1 \cdot 6 \cdot 120) + (2.3 \cdot 1 \cdot 1 \cdot 20)}{(3200 + 350 + 120 + 20)}$$

$$MF = 1.22$$

The hours-based adjusted inspection interval is therefore,

$$\text{Adjusted Inspection Interval} = 24,000/1.22 = 19,700 \text{ hours}$$

[Note, since total annual operating hours is 3690, the estimated time to reach 19,700 hours is 19,700/3690 = 5.3 years.]

Also, since the last hot gas path inspection the unit has averaged 145 normal start-stop cycles per year, 5 peaking-fast start cycles per year, and 20 base load cycles ending in trips ( $a_T = 8$ ) per year. The starts-based hot gas path maintenance interval parameters for this unit are summarized below:

	TOTAL CYCLES				Sum
	Normal Start		Peaking Fast Start		
	Normal Shutdown	Trip from Load	Normal Shutdown	Trip from Load	
Part Load Cycles	40	0	0	0	N <sub>A</sub> 40
Base Load Cycles	100	20	5	0	N <sub>B</sub> 125
Peak Load Cycles	5	0	0	0	N <sub>P</sub> 5

From the starts-based criteria, the maintenance factor is determined from Figure 42.

$$P_S = 3.5$$

$$F = 5$$

$$a_T = 8$$

$$MF = \frac{0.5N_A + N_B + 1.3N_P + P_S F + \sum_{i=1}^n (a_{Ti} - 1) T_i}{N_A + N_B + N_P}$$

$$MF = \frac{0.5(40) + 125 + 1.3(5) + 3.5(5) + (8 - 1)20}{40 + 125 + 5}$$

$$MF = 1.8$$

The adjusted inspection interval based on starts is

$$\text{Adjusted Inspection Interval} = 1200/1.8 = 667 \text{ starts}$$

[Note, since the total annual number of starts is 170, the estimated time to reach 667 starts is 667/170 = 3.9 years.]

In this case the unit would reach the starts-based hot gas path interval prior to reaching the hours-based hot gas path interval. The hot gas path inspection interval for this unit is therefore 667 starts (or 3.9 years).

## A.2) Example 2 – Hot Gas Path Factored Starts Calculation

A 7E.03 user has accumulated operating data for the past year of operation. This data shows number of trips from part, base, and peak load, as well as peaking-fast starts. The user would like to calculate the total number of factored starts in order to plan the next HGP outage. *Figure 42* is used to calculate the total number of factored starts as shown below.

### Operational history:

	TOTAL CYCLES				Sum
	Normal Start		Peaking Fast Start		
	Normal Shutdown	Trip from Load	Normal Shutdown	Trip from Load	
Part Load Cycles	35	5	0	1	N <sub>A</sub> 41
Base Load Cycles	25	35	4	2	N <sub>B</sub> 66
Peak Load Cycles	40	10	0	0	N <sub>P</sub> 50

### Total Trips

1. 50% load ( $a_{T1} = 6.5$ ),  $T_1 = 5 + 1 = 6$
2. Base load ( $a_{T2} = 8$ ),  $T_2 = 35 + 2 = 37$
3. Peak load ( $a_{T3} = 10$ ),  $T_3 = 10$

### Additional Cycles

Peaking-fast starts,  $F = 7$

From the starts-based criteria, the total number of factored starts (FS) and actual starts (AS) is determined from *Figure 42*.

$$P_s = 3.5$$

$$F = 7$$

$$FS = 0.5N_A + N_B + 1.3N_P + P_s F + \sum_{i=1}^n (a_{Ti} - 1) T_i$$

$$= 0.5 \cdot 41 + 66 + 1.3 \cdot 50 + 3.5 \cdot 7 + (6.5 - 1) 6 + (8 - 1) 37 + (10 - 1) 10 = 558$$

$$AS = N_A + N_B + N_P = 41 + 66 + 50 = 157$$

$$\text{Maintenance Factor} = \frac{FS}{AS} = \frac{558}{157} = 3.6$$

## A.3) Example 3 – Load Step Maintenance Factor Calculation

A 6F.03 gas turbine is selected to power an electro-intensive steel mill. The system is remote, not interconnected to the national grid. In order to preserve island grid stability, any sudden and uncontrolled change of the arc furnace demand is swiftly compensated by automatic change of unit power, through its built-in governor controls. Within the observed period, the un-controlled process events led the unit to execute 30 load steps beyond  $\pm 20\%$  load. *Figure 42* is used to calculate the total number of factored starts resulting from the load steps.

Load Step Amplitude (% load step)	Number of load steps	Factored Starts
$\pm 20\%$	6	1.9
$\pm 25\%$	3	1.2
$\pm 30\%$	4	2.0
$\pm 35\%$	4	2.5
$\pm 40\%$	2	1.5
$\pm 45\%$	2	1.7
$\pm 50\%$	3	3.0
$\pm 55\%$	1	1.1
$\pm 60\%$	0	0.0
$\pm 65\%$	1	1.4
$\pm 70\%$	0	0.0
$\pm 75\%$	1	1.8
$\pm 80\%$	0	0.0
$\pm 85\%$	1	2.2
$\pm 90\%$	1	2.4
$\pm 95\%$	1	2.7
$\pm 100\%$	0	0.0

The gas turbine contained all grid events to avoid process outage, resulting in total Load Step Factored Starts of 25.4

## B) Examples – Combustion Maintenance Interval Calculations (Reference Figures 39 and 40)

### DLN 1 Peak Load with Power Augmentation

+50F Tfire Increase	Natural Gas Fuel
3.5% Steam Augmentation	6 Hours/Start
Peaking Start	Wet Control Curve
Normal Shutdown (No Trip)	
Factored Hours = $K_i * A_{fi} * A_{pi} * t_i =$	34.5 Hours
<b>Hours Maintenance Factor =</b>	<b>5.8</b>
Where	$K_i = 2.34 \text{ Max}(1.0, \exp(0.34(3.50-1.00)))$ Wet $A_{fi} = 1.00$ Natural Gas Fuel $A_{pi} = 2.46 \exp(0.018(50))$ Peak Load $t_i = 6.0$ Hours/Start
Factored Starts = $K_i * A_{fi} * A_{ti} * A_{pi} * A_{si} * N_i =$	17.4 Starts
<b>Starts Maintenance Factor =</b>	<b>17.4</b>
Where	$K_i = 2.77 \text{ Max}(1.0, \exp(0.34(3.50-0.50)))$ Wet $A_{fi} = 1.00$ Natural Gas Fuel $A_{ti} = 1.00$ No Trip at Load $A_{pi} = 1.57 \exp(0.009(50))$ Peak Load $A_{si} = 4.0$ Peaking Start $N_i = 1.0$ Considering Each Start

### Standard Combustor Base Load on Crude Oil

No Tfire Increase	Crude Oil Fuel
1.0 Water/Fuel Ratio	220 Hours/Start
Normal Start	Dry Control Curve
Normal Shutdown (No Trip)	
Factored Hours = $K_i * A_{fi} * A_{pi} * t_i =$	788.3 Hours
<b>Hours Maintenance Factor =</b>	<b>3.6</b>
Where	$K_i = 1.43 \text{ Max}(1.0, \exp(1.80(1.00-0.80)))$ Dry $A_{fi} = 2.50$ Crude Oil, Std (Non-DLN) $A_{pi} = 1.00$ Base Load $t_i = 220.0$ Hours/Start
Factored Starts = $K_i * A_{fi} * A_{ti} * A_{pi} * A_{si} * N_i =$	5.9 Starts
<b>Starts Maintenance Factor =</b>	<b>5.9</b>
Where	$K_i = 2.94 \text{ Max}(1.0, \exp(1.80(1.00-0.40)))$ Dry $A_{fi} = 2.00$ Crude Oil, Std (Non-DLN) $A_{ti} = 1.00$ No Trip at Load $A_{pi} = 1.00$ Base Load $A_{si} = 1.00$ Normal Start $N_i = 1.0$ Considering Each Start

### DLN 2.6 Base Load on Distillate

No Tfire Increase	Distillate Fuel
1.1 Water/Fuel Ratio	220 Hours/Start
Normal Start	Dry Control Curve
Normal Shutdown (No Trip)	
Factored Hours = $K_i * A_{fi} * A_{pi} * t_i =$	943.8 Hours
<b>Hours Maintenance Factor =</b>	<b>4.3</b>
Where	$K_i = 1.72 \text{ Max}(1.0, \exp(1.80(1.10-0.80)))$ Dry $A_{fi} = 2.50$ Distillate Fuel, DLN $A_{pi} = 1.00$ Base Load $t_i = 220.0$ Hours/Start
Factored Starts = $K_i * A_{fi} * A_{ti} * A_{pi} * A_{si} * N_i =$	5.3 Starts
<b>Starts Maintenance Factor =</b>	<b>5.3</b>
Where	$K_i = 3.53 \text{ Max}(1.0, \exp(1.80(1.10-0.40)))$ Dry $A_{fi} = 1.50$ Distillate Fuel, DLN $A_{ti} = 1.00$ No Trip at Load $A_{pi} = 1.00$ Base Load $A_{si} = 1.00$ Normal Start $N_i = 1.0$ Considering Each Start

### DLN 2.6 Base Load on Natural Gas with Trip @ Load

No Tfire Increase	Natural Gas Fuel
No Steam/Water Injection	168 Hours/Start
Normal Start	Dry Control Curve
Trip @ 60% Load	
Factored Hours = $K_i * A_{fi} * A_{pi} * t_i =$	168.0 Hours
<b>Hours Maintenance Factor =</b>	<b>1.0</b>
Where	$K_i = 1.00$ No Injection $A_{fi} = 1.00$ Natural Gas Fuel $A_{pi} = 1.00$ Base Load $t_i = 168.0$ Hours/Start
Factored Starts = $K_i * A_{fi} * A_{ti} * A_{pi} * A_{si} * N_i =$	2.6 Starts
<b>Starts Maintenance Factor =</b>	<b>2.6</b>
Where	$K_i = 1.00$ No Injection $A_{fi} = 1.00$ Natural Gas Fuel $A_{ti} = 2.62 \text{ 0.5} + \exp(0.0125 * 60)$ for Trip $A_{pi} = 1.00$ Base Load $A_{si} = 1.00$ Normal Start $N_i = 1.0$ Considering Each Start

### DLN 1 Combustor Base Load on Distillate

No Tfire Increase	Distillate Fuel
0.9 Water/Fuel Ratio	500 Hours/Start
Normal Start	Dry Control Curve
Normal Shutdown (No Trip)	
Factored Hours = $K_i * A_{fi} * A_{pi} * t_i =$	1496.5 Hours
<b>Hours Maintenance Factor =</b>	<b>3.0</b>
Where	$K_i = 1.20 \text{ Max}(1.0, \exp(1.80(0.90-0.80)))$ Dry $A_{fi} = 2.50$ Distillate Fuel, DLN 1 $A_{pi} = 1.00$ Part Load $t_i = 500.0$ Hours/Start
Factored Starts = $K_i * A_{fi} * A_{ti} * A_{pi} * A_{si} * N_i =$	3.7 Starts
<b>Starts Maintenance Factor =</b>	<b>3.7</b>
Where	$K_i = 2.46 \text{ Max}(1.0, \exp(1.80(0.90-0.40)))$ Dry $A_{fi} = 1.50$ Distillate Fuel, DLN $A_{ti} = 1.00$ No Trip at Load $A_{pi} = 1.00$ Part Load $A_{si} = 1.00$ Normal Start $N_i = 1.0$ Considering Each Start

### DLN 2.6 Peak Load on Natural Gas with Peaking Start

+35F Tfire Increase	Natural Gas Fuel
3.5% Steam Augmentation	4 Hours/Start
Peaking Start	Dry Control Curve
Normal Shutdown (No Trip)	
Factored Hours = $K_i * A_{fi} * A_{pi} * t_i =$	12.5 Hours
<b>Hours Maintenance Factor =</b>	<b>3.1</b>
Where	$K_i = 1.67 \text{ Max}(1.0, \exp(0.34(3.50-2.00)))$ $A_{fi} = 1.00$ Natural Gas Fuel $A_{pi} = 1.88 \exp(0.018(35))$ Peak Load $t_i = 4.0$ Hours/Start
Factored Starts = $K_i * A_{fi} * A_{ti} * A_{pi} * A_{si} * N_i =$	12.8 Starts
<b>Starts Maintenance Factor =</b>	<b>12.8</b>
Where	$K_i = 2.34 \text{ Max}(1.0, \exp(0.34(3.50-1.00)))$ Dry $A_{fi} = 1.00$ Natural Gas Fuel $A_{ti} = 1.00$ No Trip at Load $A_{pi} = 1.37 \exp(0.009(35))$ Peak Load $A_{si} = 4.0$ Peaking Start $N_i = 1.0$ Considering Each Start



## C) Definitions

**Reliability:** Ability of generating units to perform their intended function. Also defined as probability of not being forced out of service when the unit is needed. Includes forced outage hours (FOH) while in service, while on reserve shutdown and while attempting to start normalized by period hours (PH) – units are %.

$$\text{Reliability} = (1 - \text{FOH}/\text{PH}) (100)$$

$$\text{FOH} = \text{total forced outage hours}$$

$$\text{PH} = \text{period hours}$$

**Availability:** Fraction of time in which a unit is capable of providing service and accounts for outage frequency and duration. Also defined as probability of being available, independent of whether the unit is needed. – Includes all unavailable hours (UH) – normalized by period hours (PH) – units are %.

$$\text{Availability} = (1 - \text{UH}/\text{PH}) (100)$$

$$\text{UH} = \text{total unavailable hours (forced outage, failure to start, scheduled maintenance hours, unscheduled maintenance hours)}$$

$$\text{PH} = \text{period hours}$$

**Starting Reliability:** A measure of the probability that a generating unit will start successfully when required. Includes actual starts (SS) – normalized by attempted starts (AS) – units are %.

$$\text{Starting Reliability} = \text{SS}/\text{AS} \times 100$$

**Service Factor:** Measure of operational use, usually expressed on an annual basis – units are %. Sometimes service hours are approximated by operational hours (include idle running).

$$\text{SF} = \text{OH}/\text{PH} \times 100$$

$$\text{OH} = \text{Operating Hours on an annual basis}$$

$$\text{PH} = \text{Period Hours (8760 hours per year)}$$

### Operating Duty Definition:

Duty	Service Factor	Fired Hours/Start
Stand-by	< 1%	1 to 4
Peaking	1% – 17%	3 to 10
Cycling	17% – 50%	10 to 50
Continuous	> 90%	>> 50

## D) Estimated Repair and Replacement Intervals (Natural Gas Only)

Repair/replace intervals reflect current production hardware, unless otherwise noted, and operation in accordance with manufacturer specifications. Consult previous revisions of GER 3620 or other unit-specific documentation for estimated repair/replace intervals of previous generation gas turbine models and hardware.

### 6B.03

	Repair Interval	Replace Interval (Hours)	Replace Interval (Starts)
Combustion Liners	CI	4 (CI)	4 (CI) / 5 (CI) <sup>(1)</sup>
Caps	CI	4 (CI)	5 (CI)
Transition Pieces	CI	4 (CI)	4 (CI) / 5 (CI) <sup>(1)</sup>
Fuel Nozzles	CI	2 (CI)	2 (CI) / 3 (CI) <sup>(4)</sup>
Crossfire Tubes	CI	1 (CI)	1 (CI)
Crossfire Tube Retaining Clips	CI	1 (CI)	1 (CI)
Flow Divider (Distillate)	CI	3 (CI)	3 (CI)
Fuel Pump (Distillate)	CI	3 (CI)	3 (CI)
Stage 1 Nozzles	HGPI	3 (HGPI)	3 (HGPI)
Stage 2 Nozzles	HGPI	3 (HGPI)	3 (HGPI)
Stage 3 Nozzles	HGPI	3 (HGPI)	3 (HGPI)
Stage 1 Shrouds	HGPI	3 (HGPI)	3 (HGPI)
Stage 2 Shrouds	HGPI	3 (HGPI)	4 (HGPI)
Stage 3 Shrouds	HGPI	3 (HGPI)	4 (HGPI)
Stage 1 Buckets	HGPI	3 (HGPI) <sup>(2)</sup>	3 (HGPI)
Stage 2 Buckets	HGPI	3 (HGPI) <sup>(3)</sup>	4 (HGPI)
Stage 3 Buckets	HGPI	3 (HGPI)	4 (HGPI)

Note: Repair/replace cycles reflect current production (6B.03) hardware, unless otherwise noted, and operation in accordance with manufacturer specifications. They represent initial recommended intervals in the absence of operating and condition experience. For factored hours and starts of the repair intervals, refer to Figure 36. Applies to Performance Improvement Program (PIP). See your GE service representative for other configurations.

CI = Combustion Inspection Interval  
HGPI = Hot Gas Path Inspection Interval

(1) 4 (CI) for non-DLN / 5 (CI) for DLN

(2) 3 (HGPI) with strip and recoat at first HGPI

(3) 3 (HGPI) for current design only. Consult your GE Energy representative for replace intervals by part number.

(4) 2 (CI) for non-DLN / 3 (CI) for DLN

**Figure D-1.** Estimated repair and replacement intervals

Contact your GE service representative for repair options. GE uses our unique proprietary knowledge of the part environment and use of specific inspection methods to address operational related damage that could potentially increase the interval replacement recommendation.

### 7E.03<sup>(7)</sup>

	Repair Interval	Replace Interval (Hours)	Replace Interval (Starts)
Combustion Liners	CI	3 (CI) / 5 (CI) <sup>(1)</sup>	5 (CI)
Caps	CI	3 (CI)	5 (CI)
Transition Pieces	CI	4 (CI) / 6 (CI) <sup>(5)</sup>	6 (CI)
Fuel Nozzles	CI	2 (CI) / 3 (CI) <sup>(6)</sup>	3 (CI)
Crossfire Tubes	CI	1 (CI)	1 (CI)
Crossfire Tube Retaining Clips	CI	1 (CI)	1 (CI)
Flow Divider (Distillate)	CI	3 (CI)	3 (CI)
Fuel Pump (Distillate)	CI	3 (CI)	3 (CI)
Stage 1 Nozzles	HGPI	3 (HGPI)	3 (HGPI)
Stage 2 Nozzles	HGPI	3 (HGPI)	3 (HGPI)
Stage 3 Nozzles	HGPI	3 (HGPI)	3 (HGPI)
Stage 1 Shrouds	HGPI	3 (HGPI)	3 (HGPI)
Stage 2 Shrouds	HGPI	3 (HGPI)	4 (HGPI)
Stage 3 Shrouds	HGPI	3 (HGPI)	4 (HGPI)
Stage 1 Buckets	HGPI	3 (HGPI) <sup>(2)/(3)</sup>	3 (HGPI)
Stage 2 Buckets	HGPI	3 (HGPI) <sup>(4)</sup>	4 (HGPI)
Stage 3 Buckets	HGPI	3 (HGPI)	4 (HGPI)

Note: Repair/replace intervals reflect current production (7121(EA) or 7E.03) hardware, unless otherwise noted, and operation in accordance with manufacturer specifications. They represent initial recommended intervals in the absence of operating and condition experience. For factored hours and starts of the repair intervals, refer to Figure 36. Applies to Performance Improvement Program (PIP) HGP Hardware. See your GE service representative for other configurations.

CI = Combustion Inspection Interval  
HGPI = Hot Gas Path Inspection Interval

(1) 3 (CI) for DLN / 5 (CI) for non-DLN

(2) Strip and Recoat is required at first HGPI to achieve 3 HGPI replace interval.

(3) Up-rated 7E machines (2055 Tfire) require GE approved repair process at first HGPI to achieve 3 HGPI replace interval.

(4) 3 (HGPI) interval requires meeting tip shroud engagement criteria at prior HGP repair intervals. Consult your GE service representative for details.

(5) 4 (CI) for DLN / 6 (CI) for non-DLN

(6) 2 (CI) for DLN / 3 (CI) for non-DLN

(7) Also applicable to 7121(EA) models.

**Figure D-2.** Estimated repair and replacement intervals

### 9E.03<sup>(6)</sup>

	Repair Interval	Replace Interval (Hours)	Replace Interval (Starts)
Combustion Liners	CI	3 (CI) / 5 (CI) <sup>(1)</sup>	5 (CI)
Caps	CI	3 (CI)	5 (CI)
Transition Pieces	CI	4 (CI) / 6 (CI) <sup>(4)</sup>	6 (CI)
Fuel Nozzles	CI	2 (CI) / 3 (CI) <sup>(5)</sup>	3 (CI)
Crossfire Tubes	CI	1 (CI)	1 (CI)
Crossfire Tube Retaining Clips	CI	1 (CI)	1 (CI)
Flow Divider (Distillate)	CI	3 (CI)	3 (CI)
Fuel Pump (Distillate)	CI	3 (CI)	3 (CI)
Stage 1 Nozzles	HGPI	3 (HGPI)	3 (HGPI)
Stage 2 Nozzles	HGPI	3 (HGPI)	3 (HGPI)
Stage 3 Nozzles	HGPI	3 (HGPI)	3 (HGPI)
Stage 1 Shrouds	HGPI	3 (HGPI)	3 (HGPI)
Stage 2 Shrouds	HGPI	3 (HGPI)	4 (HGPI)
Stage 3 Shrouds	HGPI	3 (HGPI)	4 (HGPI)
Stage 1 Buckets	HGPI	3 (HGPI) <sup>(2)</sup>	3 (HGPI)
Stage 2 Buckets	HGPI	3 (HGPI) <sup>(3)</sup>	4 (HGPI)
Stage 3 Buckets	HGPI	3 (HGPI)	4 (HGPI)

Note: Repair/replace intervals reflect current production (9171(E)) hardware, unless otherwise noted, and operation in accordance with manufacturer specifications. They represent initial recommended intervals in the absence of operating and condition experience. For factored hours and starts of the repair intervals, refer to Figure 36. Applies to Performance Improvement Program (PIP). See your GE service representative for other configurations.

CI = Combustion Inspection Interval  
HGPI = Hot Gas Path Inspection Interval

- (1) 3 (CI) for DLN / 5 (CI) for non-DLN
- (2) Strip and Recoat is required at first HGPI to achieve 3 HGPI replace interval.
- (3) 3 (HGPI) interval requires meeting tip shroud engagement criteria at prior HGP repair intervals. Consult your GE service representative for details.
- (4) 4 (CI) for DLN / 6 (CI) for non-DLN
- (5) 2 (CI) for DLN / 3 (CI) for non-DLN
- (6) Applicable to non-AGP units only

**Figure D-3.** Estimated repair and replacement intervals

### 6F.03

	Repair Interval	Replace Interval (Hours)	Replace Interval (Starts)
Combustion Liners	CI	2 (CI)	2 (CI)
Caps	CI	3 (CI)	2 (CI)
Transition Pieces	CI	3 (CI)	2 (CI)
Fuel Nozzles	CI	2 (CI)	2 (CI)
Crossfire Tubes	CI	1 (CI)	1 (CI)
Crossfire Tube Retaining Clips	CI	1 (CI)	1 (CI)
End Covers	CI	4 (CI)	2 (CI)
Stage 1 Nozzles	HGPI	3 (HGPI)	3 (HGPI)
Stage 2 Nozzles	HGPI	3 (HGPI)	3 (HGPI)
Stage 3 Nozzles	HGPI	3 (HGPI)	3 (HGPI)
Stage 1 Shrouds	HGPI	3 (HGPI)	3 (HGPI)
Stage 2 Shrouds	HGPI	3 (HGPI)	3 (HGPI)
Stage 3 Shrouds	HGPI	3 (HGPI)	3 (HGPI)
Stage 1 Buckets	HGPI	3 (HGPI)	2 (HGPI)
Stage 2 Buckets	HGPI	2 (HGPI)	3 (HGPI)
Stage 3 Buckets	HGPI	3 (HGPI)	3 (HGPI)

Note: Repair/replace intervals reflect current production (6F.03 DLN 2.6) hardware, unless otherwise noted, and operation in accordance with manufacturer specifications. They represent initial recommended intervals in the absence of operating and condition experience. For factored hours and starts of the repair intervals, refer to Figure 36.

CI = Combustion Inspection Interval  
HGPI = Hot Gas Path Inspection Interval

**Figure D-4.** Estimated repair and replacement intervals

## 7F.03

	Repair Interval	Replace Interval (Hours)	Replace Interval (Starts)
Combustion Liners	CI	2 (CI)	2 (CI)
Caps	CI	2 (CI)	2 (CI)
Transition Pieces	CI	2 (CI)	2 (CI)
Fuel Nozzles	CI	2 (CI)	2 (CI)
Crossfire Tubes	CI	1 (CI)	1 (CI)
Crossfire Tube Retaining Clips	CI	1 (CI)	1 (CI)
End Covers	CI	2 (CI)	2 (CI)
Stage 1 Nozzles	HGPI	2 (HGPI)	2 (HGPI)
Stage 2 Nozzles	HGPI	2 (HGPI)	2 (HGPI)
Stage 3 Nozzles	HGPI	3 (HGPI)	3 (HGPI)
Stage 1 Shrouds	HGPI	2 (HGPI)	2 (HGPI)
Stage 2 Shrouds	HGPI	2 (HGPI)	2 (HGPI)
Stage 3 Shrouds	HGPI	3 (HGPI)	3 (HGPI)
Stage 1 Buckets	HGPI	3 (HGPI) <sup>(2)</sup>	2 (HGPI) <sup>(4)</sup>
Stage 2 Buckets	HGPI	3 (HGPI) <sup>(1)</sup>	3 (HGPI) <sup>(1)</sup>
Stage 3 Buckets	HGPI	3 (HGPI) <sup>(3)</sup>	3 (HGPI)

Note: Repair/replace intervals reflect current production (7F.03 DLN 2.6 24k Super B and non-AGP) hardware, unless otherwise noted, and operation in accordance with manufacturer specifications. They represent initial recommended intervals in the absence of operating and condition experience. For factored hours and starts of the repair intervals, refer to *Figure 36*.

CI = Combustion Inspection Interval  
 HGPI = Hot Gas Path Inspection Interval

- (1) 3 (HGPI) for current design. Consult your GE service representative for replacement intervals by part number.
- (2) GE approved repair procedure required at first HGPI for designs without platform cooling.
- (3) GE approved repair procedure at 2nd HGPI is required to meet 3 (HGPI) replacement life.
- (4) 2 (HGPI) for current design with GE approved repair at first HGPI. 3 (HGPI) is possible for redesigned bucket with platform undercut and cooling modifications.

**Figure D-5.** Estimated repair and replacement intervals

## 7F.04/7FB.04

	Repair Interval	Replace Interval (Hours)	Replace Interval (Starts)
Combustion Liners	CI	2 (CI)	2 (CI)
Caps	CI	2 (CI)	2 (CI)
Transition Pieces	CI	2 (CI)	2 (CI)
Fuel Nozzles	CI	2 (CI)	2 (CI)
Crossfire Tubes	CI	1 (CI)	1 (CI)
Crossfire Tube Retaining Clips	CI	1 (CI)	1 (CI)
End Covers	CI	2 (CI)	2 (CI)
Stage 1 Nozzles	HGPI	3 (HGPI)	3 (HGPI)
Stage 2 Nozzles	HGPI	3 (HGPI)	3 (HGPI)
Stage 3 Nozzles	HGPI	4 (HGPI)	4 (HGPI)
Stage 1 Shrouds	HGPI	3 (HGPI)	3 (HGPI)
Stage 2 Shrouds	HGPI	3 (HGPI)	3 (HGPI)
Stage 3 Shrouds	HGPI	3 (HGPI)	3 (HGPI)
Stage 1 Buckets	HGPI	3 (HGPI)	3 (HGPI)
Stage 2 Buckets	HGPI	3 (HGPI)	3 (HGPI)
Stage 3 Buckets	HGPI	3 (HGPI)	3 (HGPI)

Note: Repair/replacement intervals reflect current production (7F.04 DLN 2.6) hardware, unless otherwise noted, and operation in accordance with manufacturer specifications. They represent initial recommended intervals in the absence of operating and condition experience. For factored hours and starts of the repair intervals, refer to *Figure 36*.

CI = Combustion Inspection Interval  
 HGPI = Hot Gas Path Inspection Interval

**Figure D-6.** Estimated repair and replacement intervals

### 9F.03

	Repair Interval	Replace Interval (Hours)	Replace Interval (Starts)
Combustion Liners	CI	2 (CI)	3 (CI)
Caps	CI	2 (CI)	3 (CI)
Transition Pieces	CI	2 (CI)	3 (CI)
Fuel Nozzles	CI	2 (CI) <sup>(1)</sup>	3 (CI) <sup>(1)</sup>
Crossfire Tubes	CI	1 (CI)	1 (CI)
Crossfire Tube Retaining Clips	CI	1 (CI)	1 (CI)
End Covers	CI	2 (CI)	3 (CI)
Stage 1 Nozzles	HGPI	2 (HGPI)	2 (HGPI)
Stage 2 Nozzles	HGPI	2 (HGPI)	2 (HGPI)
Stage 3 Nozzles	HGPI	3 (HGPI)	3 (HGPI)
Stage 1 Shrouds	HGPI	2 (HGPI)	2 (HGPI)
Stage 2 Shrouds	HGPI	2 (HGPI)	2 (HGPI)
Stage 3 Shrouds	HGPI	3 (HGPI)	3 (HGPI)
Stage 1 Buckets	HGPI	2 (HGPI) <sup>(2)</sup>	2 (HGPI) <sup>(4)</sup>
Stage 2 Buckets	HGPI	3 (HGPI) <sup>(5)</sup>	3 (HGPI) <sup>(3)</sup>
Stage 3 Buckets	HGPI	3 (HGPI) <sup>(5)</sup>	3 (HGPI)

Note: Repair/replace intervals reflect current production (9F.03 DLN 2.6+) hardware, unless otherwise noted, and operation in accordance with manufacturer specifications. They represent initial recommended intervals in the absence of operating and condition experience. For factored hours and starts of the repair intervals, refer to Figure 36.

CI = Combustion Inspection Interval  
 HGPI = Hot Gas Path Inspection Interval

- (1) Blank and liquid fuel cartridges to be replaced at each CI
- (2) 2 (HGPI) for current design with GE approved repair at first HGPI. 3 (HGPI) is possible for redesigned bucket with platform undercut and cooling modifications.
- (3) Recoating at 1st HGPI may be required to achieve 3 HGPI replacement life.
- (4) GE approved repair procedure at 1 (HGPI) is required to meet 2 (HGPI) replacement life.
- (5) GE approved repair procedure is required to meet 3 (HGPI) replacement life.

**Figure D-7.** Estimated repair and replacement intervals

### 9F.05

	Repair Interval	Replace Interval (Hours)	Replace Interval (Starts)
Combustion Liners	CI	4 (CI)	4 (CI)
Caps	CI	4 (CI)	4 (CI)
Transition Pieces	CI	4 (CI)	4 (CI)
Fuel Nozzles	CI	2 (CI) <sup>(1)</sup>	2 (CI) <sup>(1)</sup>
Crossfire Tubes	CI	1 (CI)	1 (CI)
Crossfire Tube Retaining Clips	CI	1 (CI)	1 (CI)
End Covers	CI	4 (CI)	4 (CI)
Stage 1 Nozzles	HGPI	1 (HGPI)	1 (HGPI)
Stage 2 Nozzles	HGPI	2 (HGPI)	2 (HGPI)
Stage 3 Nozzles	HGPI	3 (HGPI)	3 (HGPI)
Stage 1 Shrouds	HGPI	2 (HGPI)	2 (HGPI)
Stage 2 Shrouds	HGPI	2 (HGPI)	2 (HGPI)
Stage 3 Shrouds	HGPI	3 (HGPI)	3 (HGPI)
Stage 1 Buckets	HGPI	1 (HGPI)	1 (HGPI)
Stage 2 Buckets	HGPI	1 (HGPI)	1 (HGPI)
Stage 3 Buckets	HGPI	1 (HGPI)	1 (HGPI)

Note: Repair/replace intervals reflect current production (9F.05) hardware, unless otherwise noted, and operation in accordance with manufacturer specifications. They represent initial recommended intervals in the absence of operating and condition experience. For factored hours and starts of the repair intervals, refer to Figure 36.

CI = Combustion Inspection Interval  
 HGPI = Hot Gas Path Inspection Interval

- (1) Blank and liquid fuel cartridges to be replaced at each CI

**Figure D-8.** Estimated repair and replacement intervals

## E) Borescope Inspection Ports

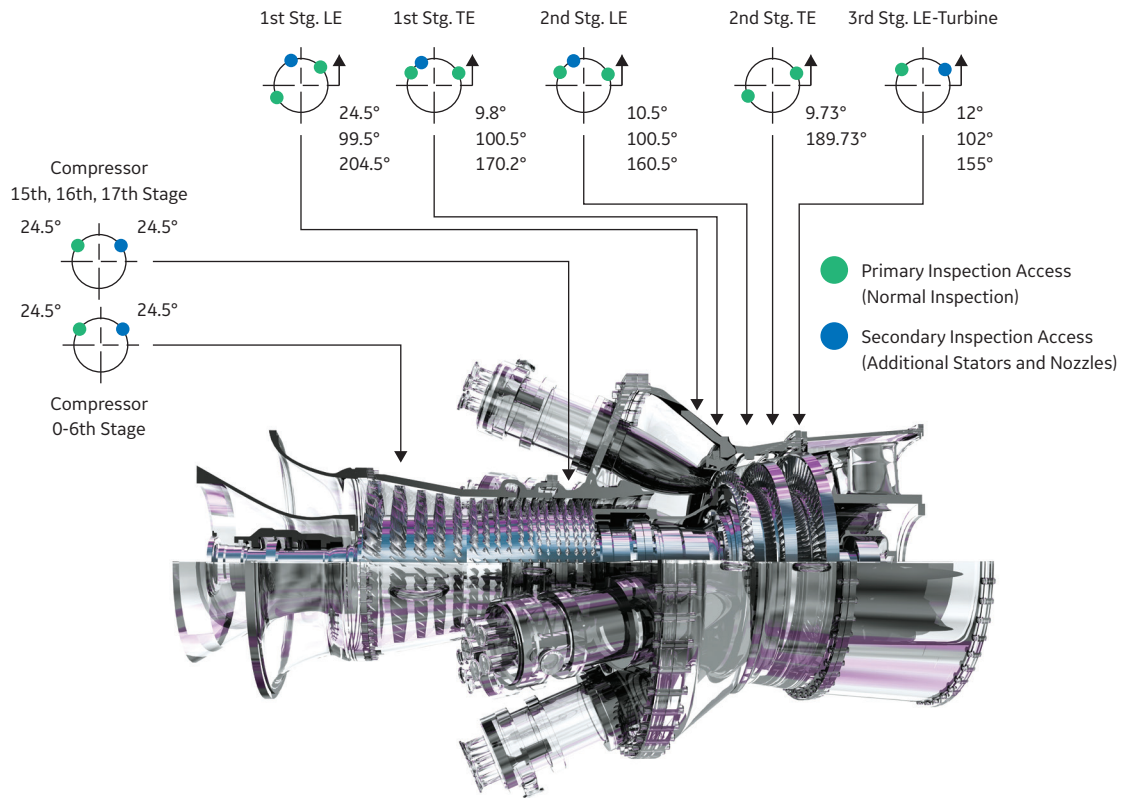

**Figure E-1.** Borescope inspection access locations for 6FA.03

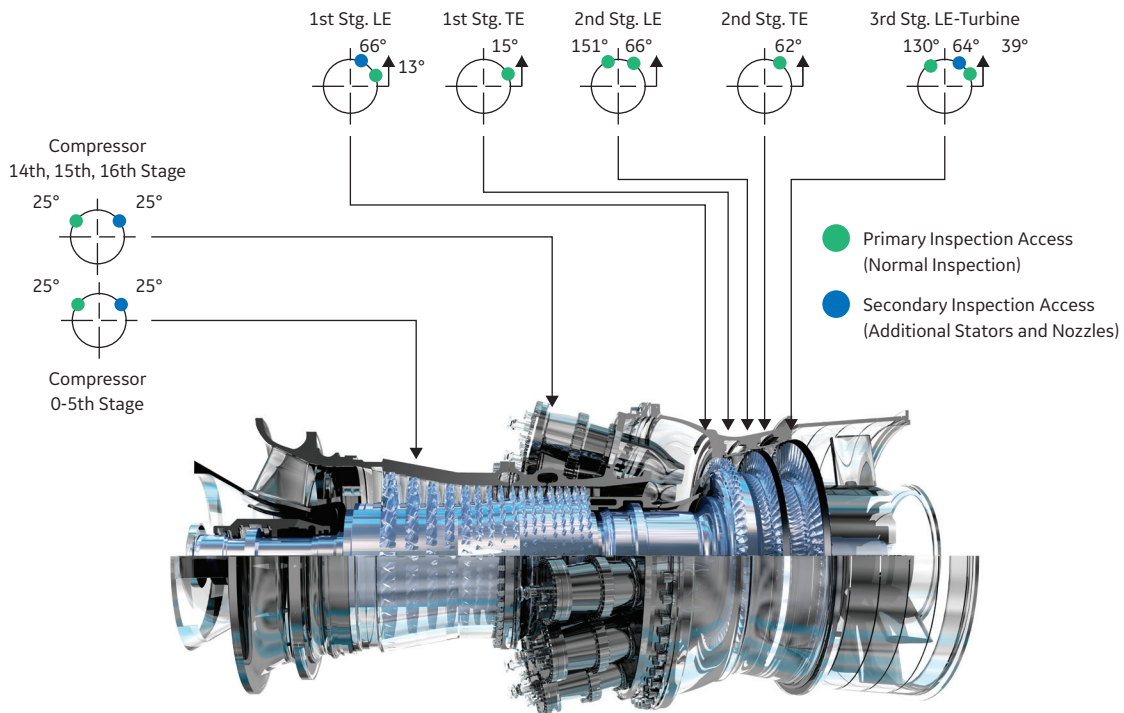

**Figure E-2.** Borescope inspection access locations for 7F.03, 7F.04, 7FB.01, 9F.03, 9F.05

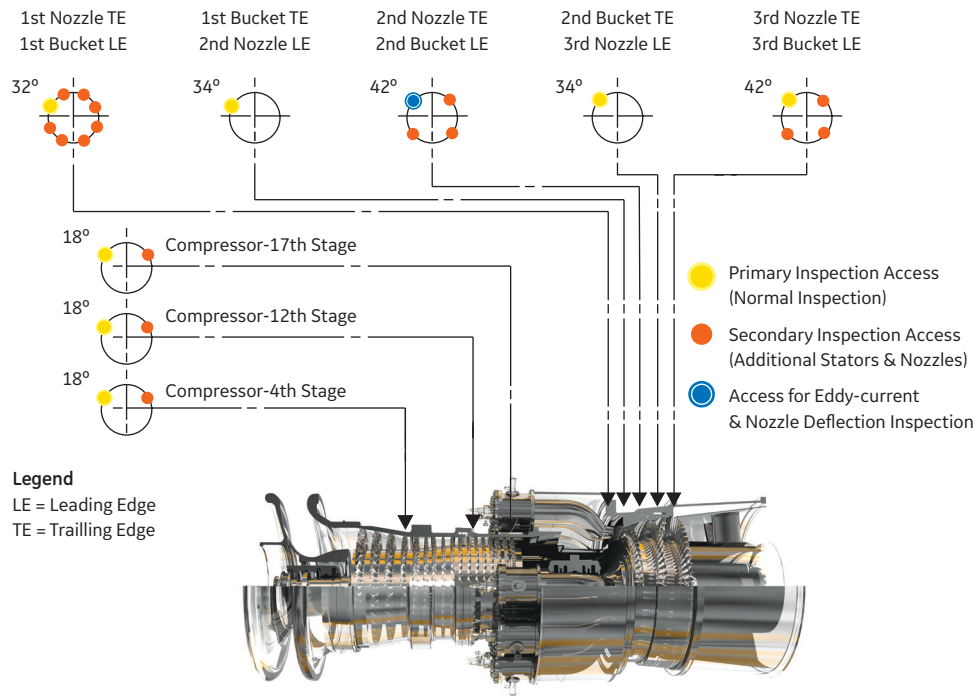

Figure E-3. 7E.03 gas turbine borescope inspection access locations

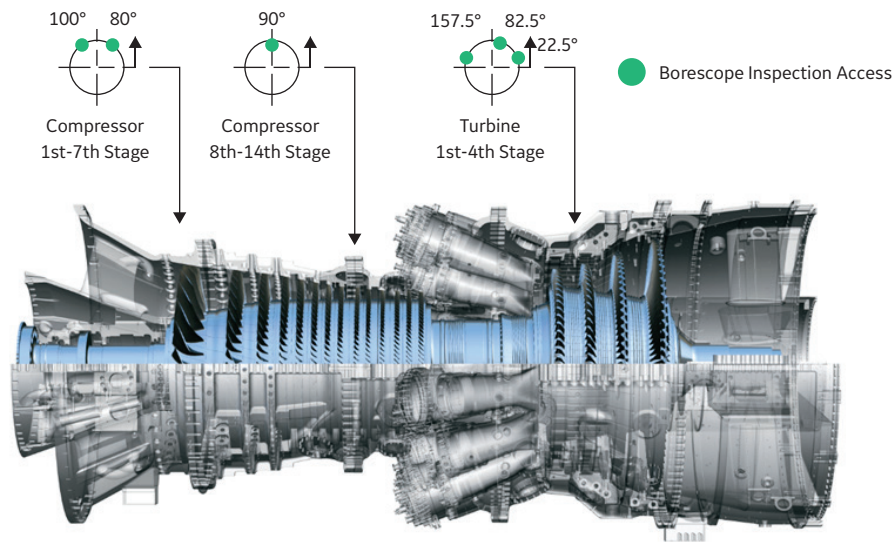

Figure E-4. 7HA.01 gas turbine borescope inspection access locations



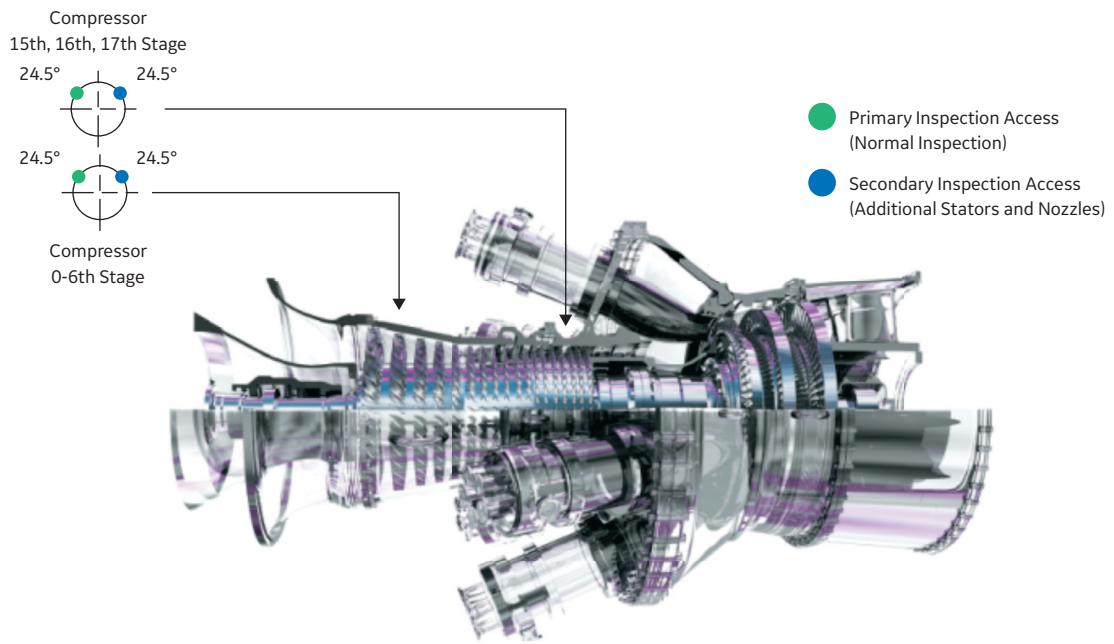

Figure E-5. 6FA.03 Borescope port locations

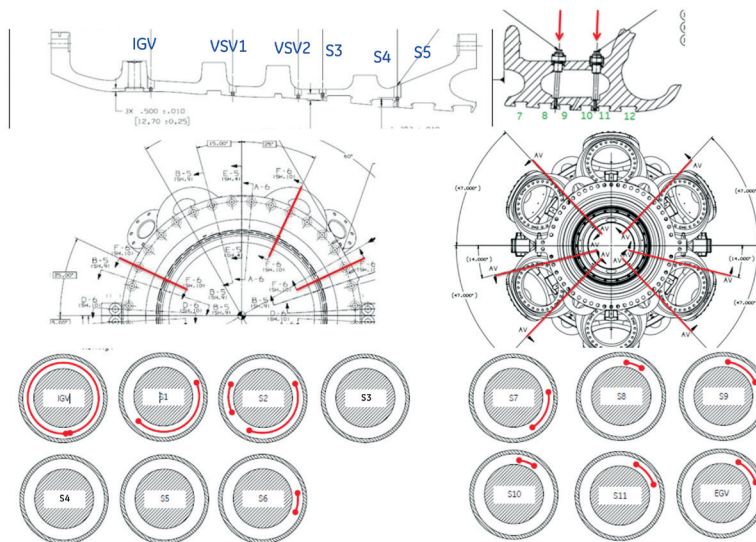
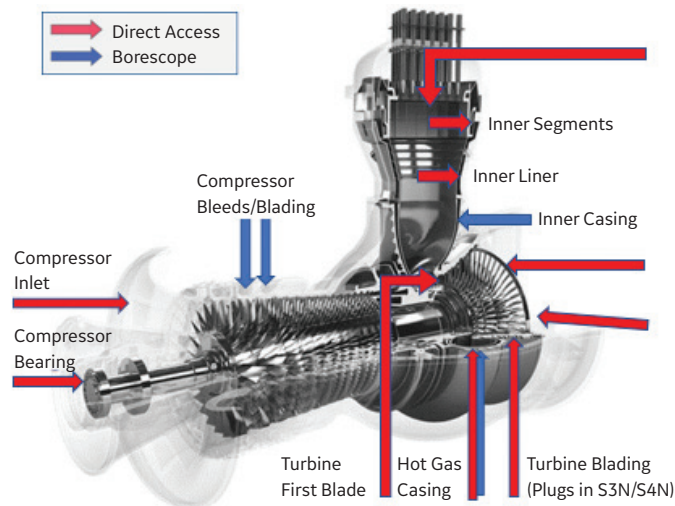
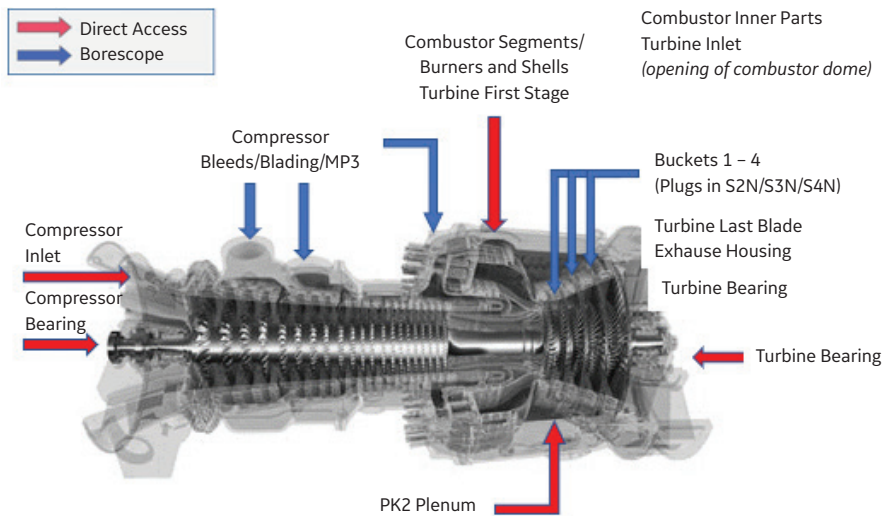

Figure E-6. Typical arrangement. See unit specific information.



**Figure E-7.** GT11N2 (Sample B – Fleet with Silo Combustor)



**Figure E-8.** GT13E2 (E-Fleet with Annular Combustor)

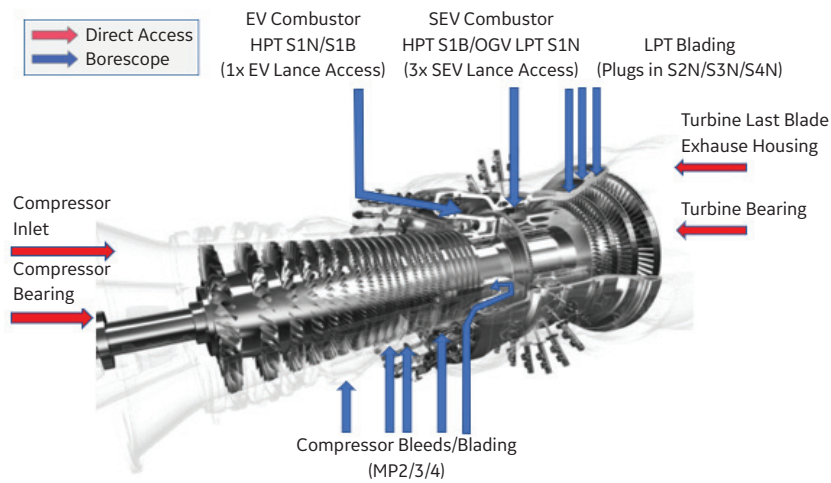

**Figure E-9.** GT24/GT26 (F – Fleet with Annular Combustor)

## F) Turning Gear/Ratchet Running Guidelines

Scenario	Turning Gear (or Ratchet) Duration
<b>Following Shutdown:</b>	
Case A.1 – Normal. Restart anticipated for >48 hours	Until wheelspace temperatures <150°F. <sup>(1)</sup> Rotor classified as unbowed. Minimum 24 hours. <sup>(2)</sup>
Case A.2 – Normal. Restart anticipated for <48 hours	Continuously until restart. Rotor unbowed.
Case B – Immediate rotor stop necessary. (Stop >20 minutes) Suspected rotating hardware damage or unit malfunction	None. Classified as bowed.
<b>Before Startup:</b>	
Case C – Hot rotor, <20 minutes after rotor stop	0–1 hour <sup>(3)</sup>
Case D – Warm rotor (rotor wheelspace temperatures >150°F <sup>(1)</sup> at turning gear speed prior to rotor stopping and wheelspace temperatures still >150°F <sup>(1)</sup> at turning gear speed after rotor turning initiated) – Rotor stopped for >20 minutes but <6 hours	4 hours
Case E.1 – Cold rotor, unbowed (all rotor wheelspace temperatures cooled below 150°F <sup>(1)</sup> at turning gear speed prior to rotor stopping) – Off turning gear <48 hours prior to restart	4 hours
Case E.2 – Cold rotor, unbowed (all rotor wheelspace temperatures cooled below 150°F <sup>(1)</sup> at turning gear speed prior to rotor stopping) – Off turning gear >48 hours prior to restart	6 hours
Case F – Cold rotor, bowed (rotor cooled down without reaching wheelspace temperatures <150°F <sup>(1)</sup> at turning gear speed prior to rotor stopping, Case B condition exists, or off turning gear for >6 hours)	8 hours <sup>(4)</sup>
<b>During Extended Outage:</b>	
Case G – When idle	1 hour daily
Case H – Alternative	No TG; 1 hour/week at full speed (no load). <sup>(5)</sup>

(1) Time depends on frame size and ambient environment.

(2) Cooldown cycle may be accelerated using starting device for forced cooldown. Turning gear, however, is recommended method.

(3) 1 hour on turning gear is recommended following a trip, before restarting. For normal shutdowns, use discretion.

(4) Follow bowed rotor startup procedure, which may be found in the unit O&M Manual.

(5) Avoids high cycling of lube oil pump during long outages.

**Figure F-1.** Turning gear guidelines

## G) B/E-, F-, and H-class Gas Turbine Naming

Frame	New Names	Former Names					
6F		6F 3-Series	6F-3	6FA	PG6101FA	6FA.01	
	6F.03			6FA+e	PG6111FA	6FA.03	
						6F Syngas	
7F	7F.03 7F.04	7F 3-Series	7F-3	7FA	PG7221FA	7FA.01	
				7FA+	PG7231FA	7FA.02	
				7FA+E	PG7241FA	7FA.03	
						7FA.04	
						7FB	
			7F Syngas				
	7F.05	7F 5-Series	7F-5	7FA.05			
7HA	7HA.01	7F 7-Series	7F-7				
	7HA.02						
9F		9F 3-Series	9F-3	9FA	PG9311FA	9FA.01	
				9FA+	PG9331FA	9FA.02	
	9F.03			9FA+e	PG9351FA	9FA.03	
	9F.04			9FA.04			
			9F 5-Series	9F-5			9FB.01
							9FB.02
9F.05						9FB.03	
9HA	9HA.01	9F 7-Series	9F-7			9FB.05	
	9HA.02						
6B		6B 3-Series	6B-3		PG6521B		
					PG6531B		
					PG6541B		
					PG6551B		
					PG6561B		
					PG6571B		
	6B.03				PG6581B		
6B.03							
6F.01	6F.01	6C	6C	6C	PG6591C		
7EA		7E 3-Series	7E-3		PG7111EA		
	7E.03				PG7121EA		
7H	7H.01	7H 7-Series	7H-7	7H	GS7072		
9E		9E 3-Series	9E-3	9E	PG9141E		
				9E	PG9151E		
				9E	PG9161E		
				9E	PG9171E		
				9E			
	9E.03			9E			
	9E.04/9E Max			9E		9E Syngas	
9EC	9EC.01	9E 5-Series	9E-5	9EC	GS9053		
9H	9H.02	9H 7-Series	9H-7	9H	GS9048	Commercial/Block 2	
				9H B2A	GS9069	Block 2A	
					G9069S	Block 2A Spares	

Figure G-1. B/E-, F-, and H-class Turbine Naming

## GE Annular/Silo Fleet Gas Turbine Naming

Series	Class	Combustor System	Rating Names	Upgrade Names	
GT8		Silo SB	B	BC	XL
		Silo EV	C		XL
		Annular EV	C2		
GT9		Silo SB Horizontal	C		
		Silo SB/U-Duct SB	D	DC+	
GT11	B	Silo SB/EV/U-Duct SB	D	DM/DMC	DM XL
		Silo SB/EV	N	NM/NMC	XL/XP
		Silo SB/EV/Lbtu	N2	XL	M
GT13		Silo SB/EV	B, C, D	DM	L/P
		Silo SB/EV	E1	MXL/ MXLC	
		E	Annular EV/AEV	E2	MXL
GT24		Sequential Annular EV + SEV	A, AB, B	MXL	MXL2
			2006		MXL2
			2011		
GT26		Sequential Annular EV + SEV	AB, B	APP	HE
			2006	APP	HE
			MXL2	-	HE

- SB - Single Burner
- Lbtu - Low Btu Burner
- EV/SEV - EnVironmental Burner/Sequential EnVironmental Burner
- AEV - Advanced EnVironmental Burner

Figure G-2. Annular/Silo Fleet Turbine Naming

## Revision History

### 9/89 Original

### 8/91 Rev A

### 9/93 Rev B

### 3/95 Rev C

- Nozzle Clearances section removed
- Steam/Water Injection section added
- Cyclic Effects section added

### 5/96 Rev D

- Estimated Repair and Replacement Cycles added for F/FA

### 11/96 Rev E

### 11/98 Rev F

- Rotor Parts section added
- Estimated Repair and Replace Cycles added for FA+E
- Starts and hours-based rotor maintenance interval equations added

### 9/00 Rev G

### 11/02 Rev H

- Estimated Repair and Replace Cycles updated and moved to Appendix D
- Combustion Parts section added
- Inlet Fogging section added

### 1/03 Rev J

- Off Frequency Operation section added

### 10/04 Rev K

- GE design intent and predication upon proper components and use added
- Added recommendation for coalescing filters installation upstream of gas heaters
- Added recommendations for shutdown on gas fuel, dual fuel transfers, and FSFS maintenance
- Trip from peak load maintenance factor added
- Lube Oil Cleanliness section added
- Inlet Fogging section updated to Moisture Intake
- Best practices for turning gear operation added
- Rapid Cool-down section added

- Procedural clarifications for HGP inspection added
- Added inspections for galling/fretting in turbine dovetails to major inspection scope
- HGP factored starts calculation updated for application of trip factors
- Turning gear maintenance factor removed for F-class hours-based rotor life
- Removed reference to turning gear effects on cyclic customers' rotor lives
- HGP factored starts example added
- F-class borescope inspection access locations added
- Various HGP parts replacement cycles updated and additional 6B table added
- Revision History added

### 11/09 Rev L

- Updated text throughout
- Casing section added
- Exhaust Diffuser section added
- Added new Fig. 26: F-class axial diffuser
- Added new Fig. 27: E-class radial diffuser
- Revised Fig. 3, 5, 7, 8, 11, 19, 20, 23, 35, 37, 38, 40, 41, 42, 43, 44, E-1, and E-2
- Appendix D – updated repair and replacement cycles
- Added PG6111 (FA) Estimated repair and replacement cycles
- Added PG9371 (FB) Estimated repair and replacement cycles

### 10/10 Correction L.1

- Corrected Fig. D-4, D-5, and D-11 combustion hardware repair and replacement cycles

### 5/14 Rev M

- Updated text throughout
- Added Fig. 14, 15, 25
- Revised Fig. 8, 10, 12, 22, 29, 34, 35, 37, 39, 41, 42, 43, 44, 45
- Updated Appendix A
- Updated Appendix D
- Added 7F.04 Estimated repair and replacement intervals
- Added Appendix G

## 10/17 Rev N

- Updated text throughout
- Updated Introduction section
- Removed reference to Fig. 3
- Moved Fig. 3 to Appendix E
- Renumbered figures
- Renumbered figure references
- Renumbered figure references in Fig. 13, 14, 37, 38, 39, 40, 42, D-1, D-2, D-3, D-4, D-5, D-6, D-7, D-8, D-9, D-10, D-11
- Updated Firing Temperatures section
- Revised and renumbered Fig. 25 (now 24)
- Updated Moisture Intake
- Removed Fig. 30 and Fig. 31
- Updated Combustion Inspection section
- Revised Fig. 34
- Updated Reference section
- Updated Appendix E figure captions
- Added Fig E-3 (formerly Fig. 3), E-4, E-5, E-6
- Removed Fig. 3, Fig 30, and Fig. 31 from List of Figures and renumbered
- Append existing Revision History:
- Revise Fig. 43 to include affect of forced cooling on rotor MF.
- Revise Fig. 31 to include VSUs
- Revise Fig. 32 to include 4th stage buckets
- Revise Fig. 36 to include 6F.01, 7F.05,7HA.01, 7HA.02, 9HA.01, and 9HA.02
- Major Inspection Maintenance Interval Basis changed from actual to factored starts/hours
- Added Digital Asset Management section
- Added Legacy Alstom Inspection Interval section
- Added Welded Rotor section
- Added Fig. 6 to illustrate EOH counting methodology
- Added double wall casing and new seal technology inspection activities.

## 2/21 Rev P

- Updated text throughout
- Added GE Annular/Silo nomenclature to introduction
- Added maintenance recommendations for GE Annular/Silo fleet
- Updated B/E-Class rotor MF
- Updated Fig. 24
- Added GE Annular/Silo combustion system configurations
- Revised Combustion Parts section
- Revised Exhaust Diffuser section
- Updated Off Frequency Operation
- Added ABC Inspections for GE Annular/Silo fleet
- Removed Frame 3 and Frame 5 from document
- Revised Fig. 36 to update existing notes and add new notes
- Increased HGP and MI interval for 6B.03, 7E.03, and 9E.03
- Revised 6F.01 HGPI starts interval
- Revised 6F.03 CI interval
- Update Fig. 39 to include available combustion systems
- Update Fig. 40 to include available combustion systems
- Update Fig. 42 to include load step factor
- Added GE Annular/Silo rotor creep life
- Revised Appendix A to include load step MF calculation
- Updated Appendix C
- Updated Appendix D to include PIP and reference GE proprietary repair methods
- Updated Appendix E to include GT11N2, GT13E2, GT24, and GT26
- Updated Appendix G to include GT8, GT9, GT11, GT13, GT24, and GT26

## List of Figures

- Figure 1. Key factors affecting maintenance planning
- Figure 2. Key technical reference documents to include in maintenance planning
- Figure 3. Borescope inspection planning
- Figure 4. Causes of wear – hot gas path components
- Figure 5. GE bases gas turbine maintenance requirements on independent counts of starts and hours
- Figure 6. Hot gas path maintenance interval comparisons. GE method vs. EOH method
- Figure 7. Maintenance factors
- Figure 8. GE maintenance intervals
- Figure 9. Estimated effect of fuel type on maintenance
- Figure 10. Peak fire severity factors - natural gas and light distillates
- Figure 11. Firing temperature and load relationship – heat recovery vs. simple cycle operation
- Figure 12. Exhaust temperature control curve – dry vs. wet control 7E.03
- Figure 13. Peaking-fast start factors
- Figure 14. 7F.03 fast start factors
- Figure 15. Turbine start/stop cycle – firing temperature changes
- Figure 16. Second stage bucket transient temperature distribution
- Figure 17. Bucket low cycle fatigue (LCF)
- Figure 18. Representative Bucket low cycle fatigue (LCF)
- Figure 19. Maintenance factor – trips from load
- Figure 20. Maintenance factor – effect of start cycle maximum load level
- Figure 21. Operation-related maintenance factors
- Figure 22. 7F gas turbine typical operational profile
- Figure 23. Baseline for starts-based maintenance factor definition
- Figure 24. DLN combustion mode effect on combustion hardware
- Figure 25. F-class axial diffuser
- Figure 26. E-class radial diffuser
- Figure 27. Maintenance factor for overspeed operation ~constant TF
- Figure 28. Deterioration of gas turbine performance due to compressor blade fouling
- Figure 29. 7E.03 heavy-duty gas turbine – disassembly inspections
- Figure 30. Operating inspection data parameters
- Figure 31. Combustion inspection – key elements
- Figure 32. Hot gas path inspection – key elements
- Figure 33. Stage 1 bucket oxidation and bucket life
- Figure 34. Gas turbine major inspection – key elements
- Figure 35. First-stage nozzle repair program: natural gas fired – continuous dry – base load
- Figure 36. Baseline recommended inspection intervals: base load – natural gas fuel – dry
- Figure 37. ABC Inspections
- Figure 38. Annular/Silo Fleet Inspection Intervals
- Figure 39. Combustion inspection hours-based maintenance factors
- Figure 40. Combustion inspection starts-based maintenance factors
- Figure 41. Hot gas path maintenance interval: hours-based criterion
- Figure 42. Hot gas path maintenance interval: starts-based criterion
- Figure 43. Legacy Alstom Inspection Interval Counting Methods
- Figure 44. Rotor maintenance interval: hours-based criterion
- Figure 45. Rotor maintenance interval: starts-based criterion
- Figure 46. Annular/Silo Fleet Rotor Life
- Figure D-1. Estimated repair and replacement intervals
- Figure D-2. Estimated repair and replacement intervals
- Figure D-3. Estimated repair and replacement intervals
- Figure D-4. Estimated repair and replacement intervals
- Figure D-5. Estimated repair and replacement intervals
- Figure D-6. Estimated repair and replacement intervals
- Figure D-7. Estimated repair and replacement intervals
- Figure D-8. Estimated repair and replacement intervals
- Figure E-1. Borescope inspection access locations for 6FA.03
- Figure E-2. Borescope inspection access locations for 7F.03, 7F.04, 7FB.01, 9F.03 and 9F.05
- Figure E-3. 7E.03 gas turbine borescope inspection access locations
- Figure E-4. 7HA.01 borescope inspection access locations
- Figure E-5. 6FA.03 Borescope inspection access locations
- Figure E-6. Typical arrangement. See unit specific information.
- Figure E-7. GT11N2 (Sample B – Fleet with Silo Combustor)
- Figure E-8. GT13E2 (E-Fleet with Annular Combustor)
- Figure E-9. GT24/GT26 (F – Fleet with Annular Combustor)
- Figure F-1. Turning gear guidelines
- Figure G-1. B/E-, F, and H-class turbine naming
- Figure G-2. Annular/Silo Fleet Turbine Naming



## Acknowledgments

Tim Lloyd, Michael Hughes, and Bob Hoeft dedicated many hours to the detailed development of this document and their hard work is sincerely appreciated. Ty Balkcum, Jerry Sasser, Patrick Bowling, Tom Stroud, Matt Ferslew, Gang Qian, John Memmer, Peter Marx, Steve Wassinger, Mardy Merine, Mike McDufford, Matt Roberts, James Bryant, Bryan Delaney, Tony Loprinzo, Nathan Race, Laura Smith and Rebecca Fiegl are also acknowledged for significant contributions to the current revision.





GTD-222, GTD-241, GTD-450, GECC-1, FSX-414, N-155 and Extendor are trademarks of the General Electric Company.

©2017, General Electric Company. All rights reserved.

GER-3620P (2/21)