

MS6001FA – AN ADVANCED-TECHNOLOGY 70-MW CLASS 50/60... Hz GAS TURBINE

J. Ramachandran and M.C. Conway
GE Power Systems
Schenectady, NY

ABSTRACT

The MS6001FA heavy-duty gas turbine is aerodynamically scaled from the MS7001FA and MS9001FA gas turbines to produce 70 MW of high-efficiency power. It uses advanced aircraft engine technology in its design with a rating based on a firing temperature class of 2350 F/1288 C and can be applied to both 50 Hz and 60 Hz markets since it drives a generator through a reduction gear at the compressor end. This produces 70 MW of simple-cycle power at more than 34% efficiency and nearly 110 MW of combined-cycle power at more than 53% efficiency. It is packaged with accessories to provide quick and cost-effective installations, making simple, cost-effective solutions to repowering, combined-cycle installations and Integrated Gasification Combined-Cycle (IGCC) plants ideal.

INTRODUCTION

The MS6001FA heavy-duty gas turbine has been successfully launched into the marketplace with five units to be produced during the first year of production. Commercial operation of the first two projects is scheduled for October 1996. Marketplace acceptance of the MS6001FA is high because it addresses the need for packaged, high-efficiency power plants in the 100-MW combined-cycle range.

The 6FA gas turbine is an aerodynamic scale of

the 7FA, just as the 9FA is derived from the 7FA. By scaling a proven advanced-technology design and combining it with advanced aircraft engine cooling and sealing technology, the 6FA gas turbine benefits from the experience gained in more than 500,000 fired hours of operation.

The 6FA is also based on another proven GE gas turbine product — the MS6001B. The modular, packaged design characteristics of the 6B have 30 years of experience in addressing customer needs for high-speed geared gas turbines. By applying these same concepts to the 6FA, simple- and combined-cycle designs have been developed that allow power train components to be shipped assembled for both 50 Hz and 60 Hz applications (Figure 1).

Table 1 compares the 6FA performance data with that of the 6B and the 7FA. The 6FA offers a 79% higher rating than the 6B (70.1 MW vs. 39.2 MW) and has an overall combined-cycle thermal efficiency (54%) typical of the more advanced F-technology gas turbines.

As the world's power generation needs continue to grow, interest in highly efficient medium-sized gas turbines for both simple- and combined-cycle applications is becoming more of a market need that the 6FA is positioned to address.

This paper discusses the design, development and product introduction of the 70-MW class 6FA gas turbine, the latest addition to GE's F-technology product line.

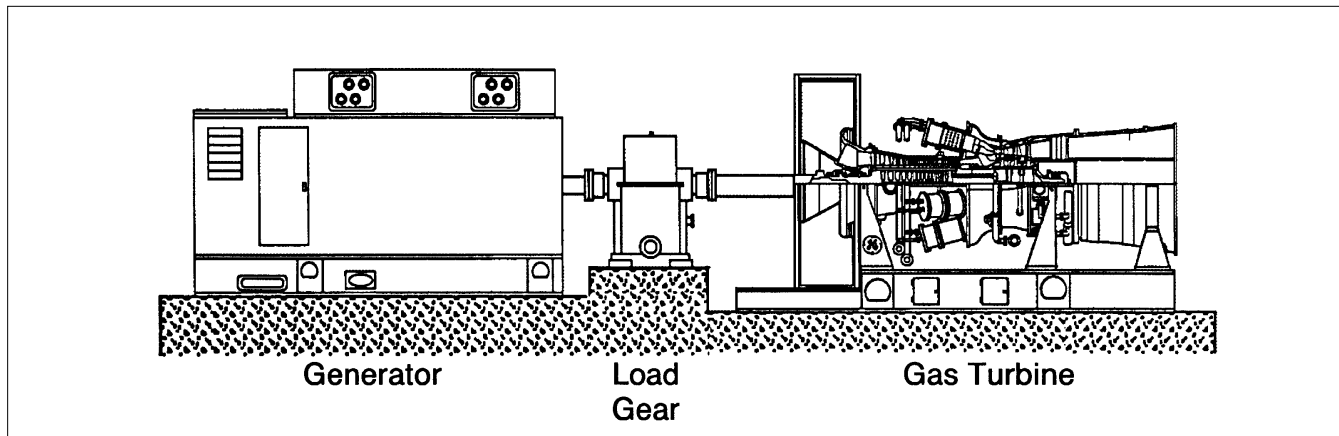

Figure 1. Typical gas turbine generator arrangement

GT25753

**Table 1
COMPARISON OF GAS TURBINE RATINGS (ISO, BASE, 60 Hz)**

	Simple-Cycle			Combined-Cycle			
	6001B	6001FA	7001FA	S106B	S106FA	S107FA	S206FA*
Output (MW)	39.2	70.1	167.8	59.8	107.1	258.8	218.7/217.0
Heat Rate (kJ/kWh)	11,320	10,530	9,940	7,390	6,795	6,425	6,605/6,705
Efficiency LHV	31.8%	34.2%	36.2%	48.7%	53.0%	56.0%	54.1/53.7
Air flow (kg/s)	138	196	432	138	196	432	196
Pressure ratio	11.8	14.9	14.8	11.8	14.9	14.8	14.8
Firing Temp. (F/C)	2020/1104	2350/1288	2350/1288	2020/1104	2350/1288	2350/1288	2350/1288
Exhaust gas Temp. (F/C)	1006/541	1107/597	1102/594	1000/538	1107/597	1117/603	1107/597
Gas Turbine Speed (rpm)	5,100	5,250	3,600	5,100	5,250	3,600	5,250
* 50 Hz/60 Hz							

GT24370

DESIGN APPROACH

The 6FA gas turbine is a 0.69 scale of the 7FA, just as the 9FA is a 1.2 aerodynamic scale of the 7FA (Figure 2). GE has used aerodynamic scaling in gas turbine development for more than 30 years. This technique is exemplified in the derivative design of the 6B and 9E gas turbines, which were scaled from the 7E. The success of this gas turbine product family in worldwide power generation service illustrates the benefits of aerodynamic scaling.

During all aspects of the 6FA's design, careful attention was paid to experience gained during the 500,000 fired hours of operation with F technology gas turbines. The F-technology fleet represents the most proven advanced-technology available. The fleet experience leader, located at Virginia Power's Chesterfield Station, has 35,000 hours of fired hours experience.

Today, F-technology combined-cycle power plants are operating in excess of 55% efficiency with reliability in the mid to high 90s. Table 2

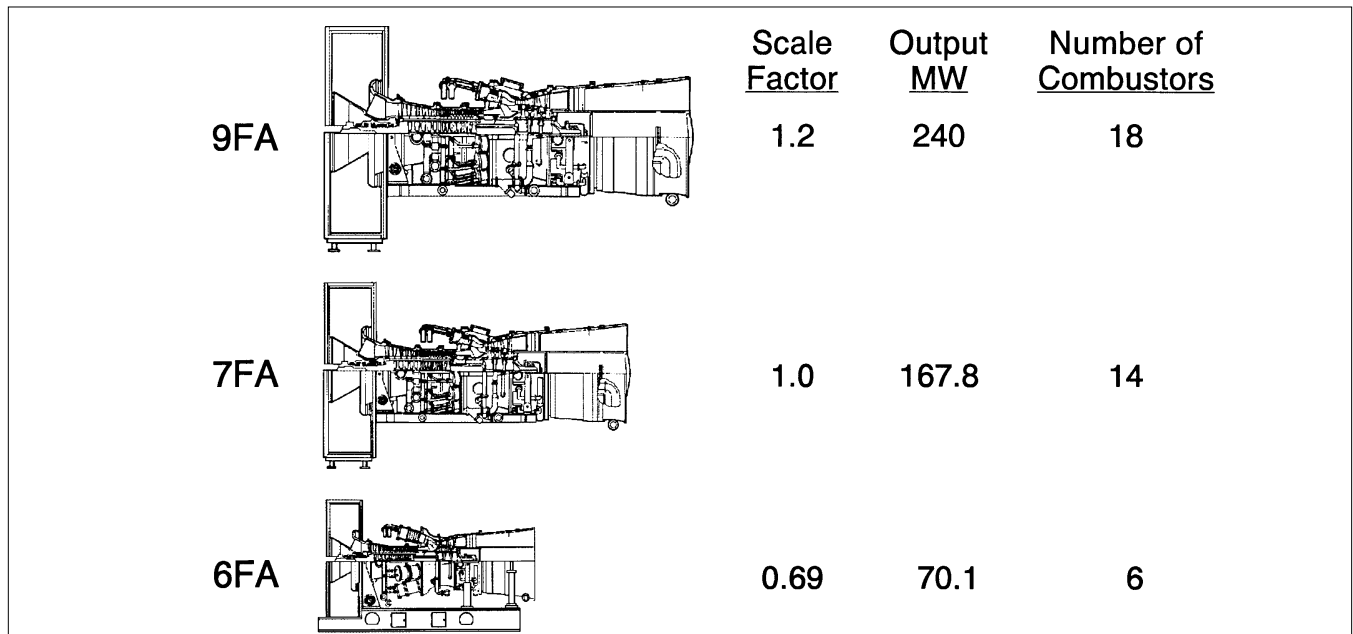

GT24596A

Figure 2. GE F product line

Table 2
6FA MATERIALS

Component	Material	Experience
Casings		
Inlet case	Ductile iron	All Fs
Compressor	Ductile iron	All Fs
Compressor discharge case	2 1/4 Cr-Mo	All Fs
Turbine shell	2 1/4 Cr-Mo	All Fs
Exhaust frame	Carbon steel	All Fs
Compressor		
Blading	C450/403+ Cb	All Fs
Wheels		
Compressor	NiCrMoV/CrMoV	All Fs
Turbine	IN-706	All Fs; complete rotor since 3Q95
Combustion		
Transition piece	Nimonic 263	All Fs and DLN systems
Liner	HASTX/HS-188	All Fs and DLN systems
Buckets		
Stage 1	GTD-111DS	All Fs, 6B
Stage 2	GTD-111	All Fs
Stage 3	GTD-111	All Fs
Nozzles		
Stage 1	FSX-414	All 6Bs, Fs, EAs
Stage 2	GTD-222	All Fs, EAs
Stage 3	GTD-222	All Fs, EAs

shows a listing of materials used in primary components of the 6FA, all of which have a proven history in GE heavy-duty gas turbines for power generation.

Extensive component and full-unit testing is an integral part and cornerstone of the process of new product introduction. During the nine-year development cycle of the MS7001F, component testing confirmed design assumptions. In addition to these tests, loaded instrumented tests were also performed in Greenville, South Carolina, and at

Virginia Power's Chesterfield station. In addition, an instrumented load test was completed on the 9F in France. Instrumented full-load tests of 7FAs at Sithe Energy, New York, and Florida Power and Light and of a 9FA at Medway, United Kingdom, formed the baseline from which the 6FA was designed.

The 6FA gas turbine configuration includes an 18-stage compressor, six combustion chambers and a three-stage turbine (Figure 3). The shaft is supported on two bearings, as it is in the 7FA, 9FA,

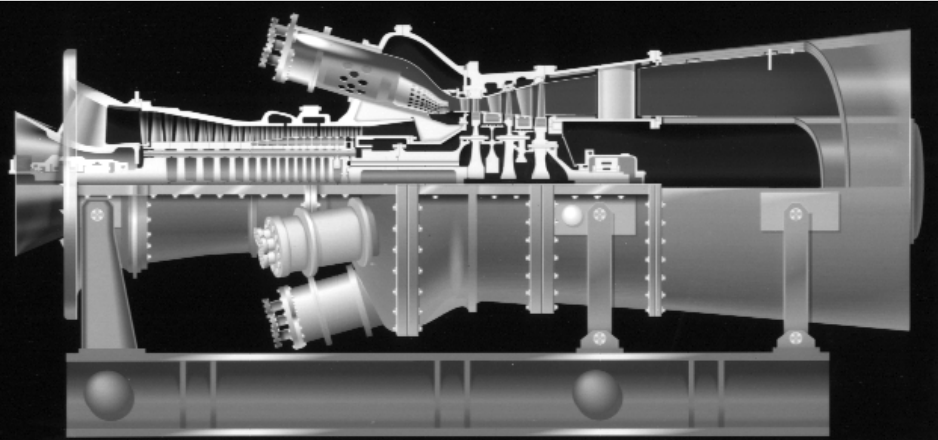
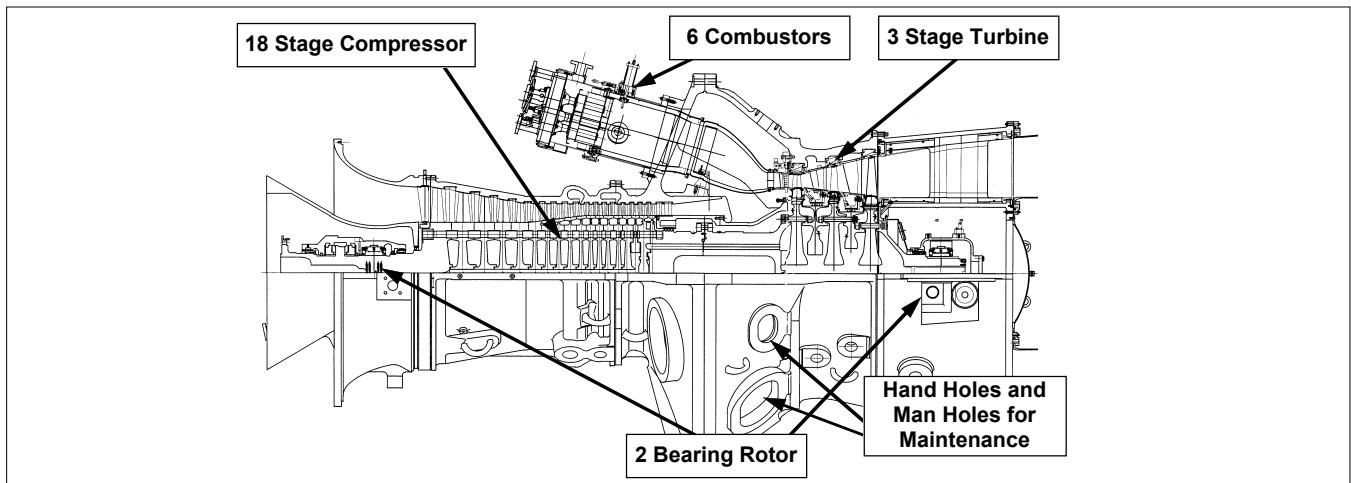

Figure 3. 6FA gas turbine

RDC27030-1



GT25694

Figure 4. Gas turbine configuration

5P and 6B gas turbines. This design was made to enhance the maintainability of these gas turbines.

Five casings form the structural shell: the inlet casing, compressor casing, compressor discharge casing, turbine shell and exhaust frame. Figure 4 shows the gas turbine section in more detail. The aft diffuser is attached to the exhaust frame and is shipped assembled on the turbine base with the thermal insulation factory-installed. The inlet plenum and the unit piping and wiring are shipped assembled with the unit on the base.

The basic gas turbine compressor has an evolutionary 30-year history and originates from the MS5001 (Figure 5). The compressor rotor uses NiCrMoV and CrMoV in its rotor construction, alloys similar to those used on the 7FA. The compressor rotor has grit-blasted flange surfaces, enhancing torque transmissibility by a minimum of 70% over untreated flange surfaces. Compressor extraction air, which does not require external coolers, provides the cooling for the first

two stages of buckets and all three stages of nozzles. The cooling circuit for the buckets is internal to the rotor and there is no loss of air in its transfer at stationary to rotating seals. The compressor air extraction locations are similar to the 7FA. Airfoil materials used in the compressor are the same as those used on the 7FA and do not require coatings.

The combustion system comes in two variations, both of which are capable of multi-fuel applications (natural gas, distillate oil, propane and fossil fuels):

- Dry Low NO_x (DLN) — standard offering
- Integrated Gasification Combined Cycle (IGCC) — option for using a wide spectrum of low heating value fuels, including gasified coal or heavy oil and steel mill gases

The combustion system is comprised of six chambers that are similar to the 9FA in design and operating conditions, and also uses common head end components (nozzles, swirlers, cap and

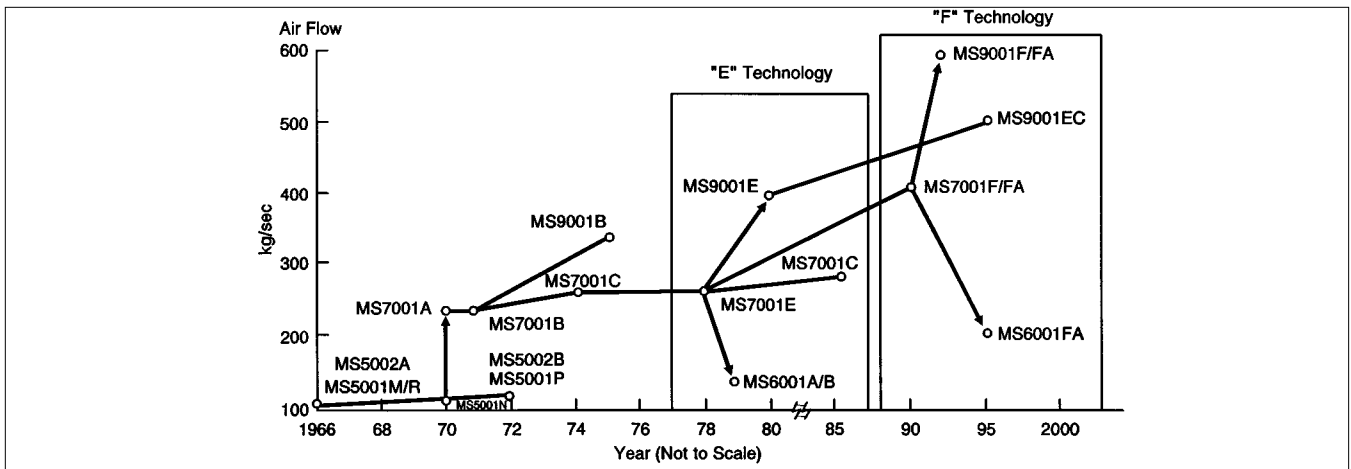

GT25755

Figure 5. Growth in compressor design evolution

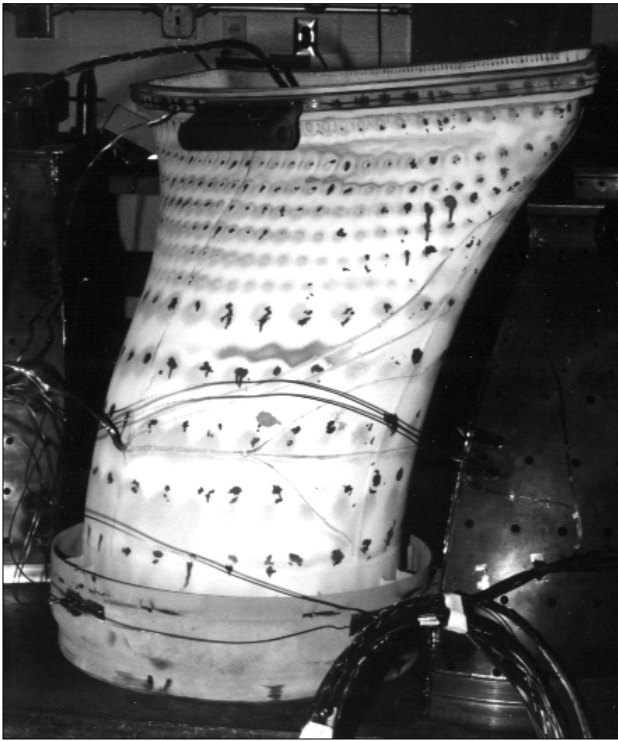

RDC27664-11

Figure 6. Thermal paint verification test for transition piece

end cover) with the 9FA. Commonality is afforded by the fact that the flow per can in the 6FA is within 2% of the 9FA. A further improvement of the 6FA combustion system is the integral multiple of stage 1 nozzle vanes with the number of combustors. This provides for a repeatable, chamber-to-chamber, thermal distribution going into the stage 1 nozzles. The large exit span of the transition pieces, which resulted from a six-chamber configuration, has been engineered using state-of-the-art analytical techniques. Cold flow visualization tests coupled with computational fluid dynamic and finite element stress analyses have been used in optimizing the transition piece geometry. Analytical predictions have been verified with full temperature and pressure combustion tests on a fully instrumented transition piece. Figure 6 shows another transition piece used in a temperature verification test using thermal paint.

Emissions levels are at 25/15 ppm NO_x/CO with a DLN system, in the range of 40% to 100% load operating on natural gas. For operation in distillate oil with water or steam injection, the levels are 42/15 ppm NO_x/CO. Up to 5% steam may be used for power augmentation.

The turbine rotor is a scale of the current 7FA. The turbine wheels, spacers and aft shaft are made from INCO 706 with INCO 718 bolting, similar to the current 7FA. As in the compressor, the turbine rotor also has grit-blasted flange sur-

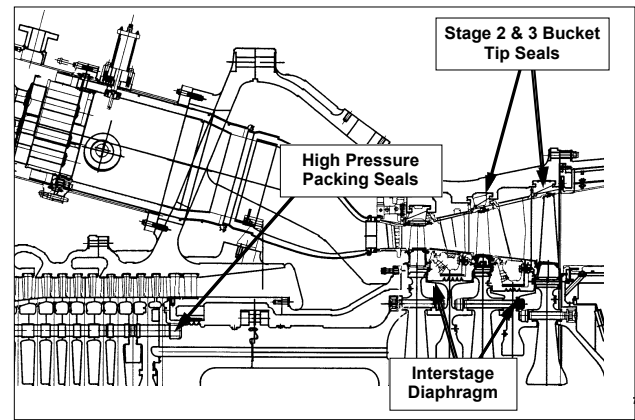

GT25770

Figure 7. Honeycomb seal locations

faces for enhanced torque transmissibility. The airfoil and coating materials used in the turbine are the same as those used in the 7FA.

The 6FA also incorporates a number of other features to its design to enhance performance and endurance:

- Static honeycomb seals and coated rotating cutter teeth are used in locations (Figure 7) that significantly affect performance. These include the high pressure packing seal, turbine interstage diaphragm seals and bucket tip seals. Performance is improved through tighter clearances at these seal locations.
- Extensive experience has been accumulated with honeycomb seals. They have been used in similar applications on GE Aircraft Engines since the early 1960s. They have also been successfully used on GE Power Generation heavy duty design units since 1994 on 7EA, 9E and 6B units.
- Tighter compressor blade and bucket tip clearances are also maintained by equivalent thermal masses distributed around the periphery of the casings (Figure 8), which provide compensation for the cold flanges at the split lines. This provides for rounder casings and tighter tip clearances during operation.
- External casing flanges use an optimized bolting arrangement for reduced leakage, which has been validated by factory tests. This results in less power required for compartment cooling and an overall improvement in performance.
- Reduced use of cooling air in the hot section of the turbine. Judicious use of cooling air for airfoil and shroud cooling in the stage 1 nozzle, bucket, shroud and stage 2 nozzle have allowed for more uniform temperature gradients that improve life and performance. The

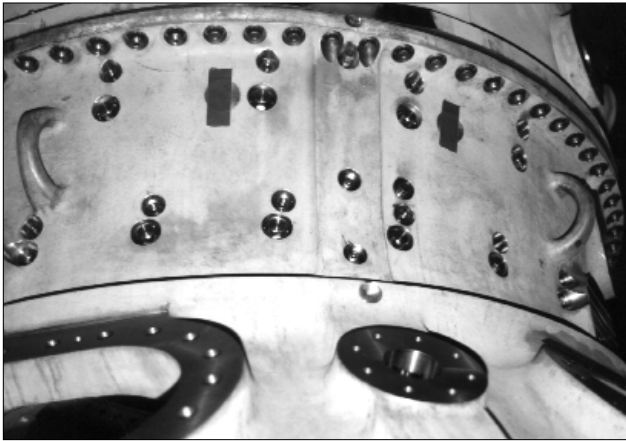

RDC227644-8

Figure 8. Typical equivalent “thermal mass” to cold flanges at split line

stage 1 bucket serpentine circuit has enhanced leading edge cooling and cast-in cooling slots at the trailing edge, to improve life in these areas.

The 6FA load gear (Figure 9) was developed in association with a world-class gear manufacturer, Renk AG, of Augsburg, Germany. In design, the 6FA load gear is a horizontally offset gearbox designed to transmit 90 MW with a 1.1 service factor, as defined per American Petroleum Institute (API) specifications. The shaft power output from the 6FA gas turbine is driven through a flexible coupling to the high-speed pinion. The low-speed bull gear drives the generator through a rigidly coupled quill shaft that operates at either 3,600 rpm or 3,000 rpm. The 6FA gear is furnished with case carburized and precision ground double-helical gearing. The high-speed and low-speed shafts are mounted on babbitt-lined, offset, half-type sleeve bearings. The bearing housings are integral to the steel-fabricated casing, and provisions are provided for bearing metal thermocouples and eddy current vibration probes. The load gear also incorporates provisions for mounting a turning gear to the high-speed shaft for establishing unit breakaway during startup.

A new level of understanding in the design of load gears has been achieved in the design and development of the 6FA load gear. Resources from GE Power Systems, GE Aircraft Engines and specialists at GE Corporate Research and Development were used in the design, development and reliability assurance studies of the 6FA load gear. Included in the process were review and approval of:

- Design parameters
- Stress and life analyses
- System lateral and torsional analyses
- Material specifications
- Forging supplier processes

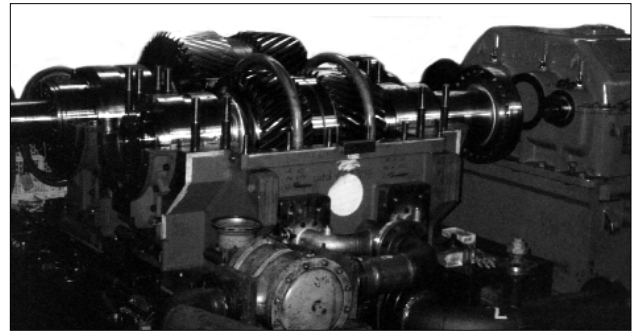

RDC27664-09

Figure 9a. Load gear in assembly at Renk AG

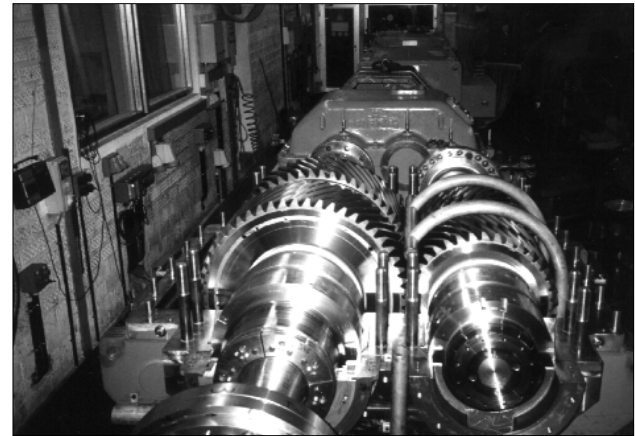

RDC27664-10

Figure 9b. Load gear in assembly at Renk Ag

- Non-destructive testing (NDT) procedures
- First-part qualification and testing

The generator applied with the 6FA gas turbine is GE's model 7A6C. The 7A6C has a proven history; it is a fully packaged, base-mounted unit that has been installed with GE's higher-rated frame 7EA gas turbines since the early 1990s. As of August 1996, approximately 100 7A6C generators have been shipped; 90 are in operation. It is available in both open-ventilated and water-to-air cooled (TEWAC) configurations and with either brushless or static exciters. It can accommodate motor start or static start options and is applicable to both 50 Hz and 60 Hz systems. An excellent reliability record has been recorded during the past five years.

When applied at the lower 6FA rating, the increased capability yields lower operating temperatures and enhanced reliability. The increased thermal capability can accommodate demanding off-voltage, off-frequency conditions and can meet a wide range of requirements.

RELIABILITY AND MAINTAINABILITY

The design of the 6FA and 7FA gas turbines has focused on operating reliability and maintainability. Reference 2 reports the development of reliability features in the controls and accessories. Redundancy has been designed into the controls and accessories areas of the gas turbine power plant to meet these goals.

The Mark V control applied to the 6FA, similar to the 7FA has a triple-redundant, microprocessor-based computer control. During normal operation, three computers share control of the gas turbine. Should one of the computers or one of the triple-redundant sensors fail, internal voting logic switches control of the gas turbine to the two remaining control computers and associated sensors. Alarms that indicate a fault in the other computer or its system of sensors are displayed. Upon repair, the two remaining computers interrogate the repaired system to ensure that it is functioning properly.

Upon determining its proper function, the three computers again share the responsibility for controlling the gas turbine. This type of control system has raised reliability from a mean-time-between-forced-outages of 3,800 hours to 30,000 hours, as demonstrated in an EPRI-sponsored test on an operating MS7001 on the Salt River Project system at their Santan site.

Redundancy has been designed into the 6FA accessory systems in all areas, including filters, pumps and compressors, similar to the 7FA. Redundancy of apparatus and power supply duplication, including crossover of sources, transformers, switchgear for medium and low voltage and DC chargers and batteries for emergency supply, ensure starting, on-line reliability and equipment safety.

Maintainability has been considered with a step-by-step analysis of:

- Handling means for routine or daily inspections in each module. Borescope inspection ports have been provided for inspecting 5 stages of the compressor and all 3 stages of the turbine. Four man-holes and six hand-holes are also provided (Figure 4) for routine inspections of the transition pieces and attaching seals.
- Major inspections of the gas turbine and the main auxiliaries
- Special maintenance needs, such as rotor removal, using specially-designed tools such as trolleys for generator rotors or hoists fitted to cranes for the turbine rotor

With the 6FA being approximately the same

size as the 6B, and with fewer combustion chambers (six vs. eight), installation and maintenance times are conservatively estimated to be the same as the 6B. Easy access to the Dry Low NO_x combustion system was a primary focus in the design of the piping systems.

Finally, an approximate 25% parts count reduction in compressor, combustor and turbine components, in comparison to the 7FA and 9FA, should manifest in faster and easier field maintenance operations.

PLANT ARRANGEMENT

The most frequent applications for the 6FA are expected to be in mid-range and base load service as part of combined-cycle or co-generation plants. Taking these requirements into account, the 6FA gas turbine, like the 7FA, is designed specifically for combined-cycle applications with the following features:

- A cold-end drive gas turbine, which allows the exhaust to be directed axially into the heat recovery steam generator
- Factory-assembled accessory packages on separate skids for easy installation and maintainability
- An off-base turbine enclosure that provides more space for maintenance and better control of noise emissions
- High compressor discharge extraction capability for Integrated Gasification Combined Cycle (IGCC) applications
- Slab-mounted single- (Figure 10) or multi-shaft (Figure 1) configurations

Air enters the unit through a standard single-stage, multiple-element filter located above the generator and provides fouling protection for the gas turbine. Exhaust gases from the gas turbine go through an axial exhaust diffuser, pass through silencers, and either enter the heat recovery boiler or exit to the stack.

As discussed, the shaft power output from the gas turbine is driven through a flexible coupling attached to its cold end, to the high-speed pinion of the load gear. The low-speed bull gear drives the generator through a rigidly coupled quill shaft. A turning gear for breakaway during startup is attached to the blind end of the pinion gear.

A motor torque converter that drives through the generator is the standard starting means. However, the generator can be a starting motor when supplied with a static frequency converter (SFC). The generator shaft end is kept free when this technique is used. The torque level can be readily adjusted to permit fast starts and slow cool-

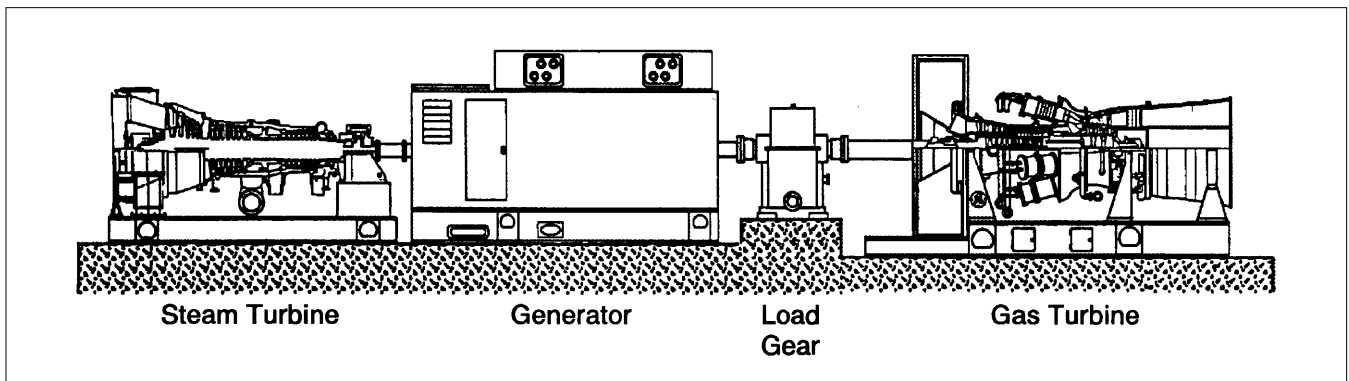

GT25758

Figure 10. Slab-mounted single-shaft arrangement

down rotation of the gas turbine. A disconnecting coupling or clutch can also be installed to allow synchronous condenser operation.

The mechanical accessories are motor driven and arranged in two modules. One of these modules is used only for liquid fuel operation. Electrical devices, such as auxiliary transformers, switchgears, static frequency converters, are contained in the electrical/control module close to the generator. The modules are fully assembled and factory-tested prior to shipment. The two mechanical accessory modules are located at fixed locations relative to the gas turbine, which allows for quick field installations using prefabricated piping.

An array of site-specific designs for these modules provides:

- Aesthetic appearance

- Thermal and acoustic insulation
- Heating and ventilation
- Fire protection
- Redundancy of power supply
- Space and means available for maintenance

These features are established for each plant according to customer requirements and service considered (in/out door, new/existing plant, etc.). Additionally, the skid layouts for the various systems have generous space to permit easy maintenance without speciality tools.

The typical general plant arrangement (Figure 11) can be adapted to many indoor or outdoor configurations. However, the location of the two main accessory modules must be retained, and the off-base gas turbine enclosure must be used to achieve 85dBA maximum sound from the unit. To minimize field installation work, the gas turbine is

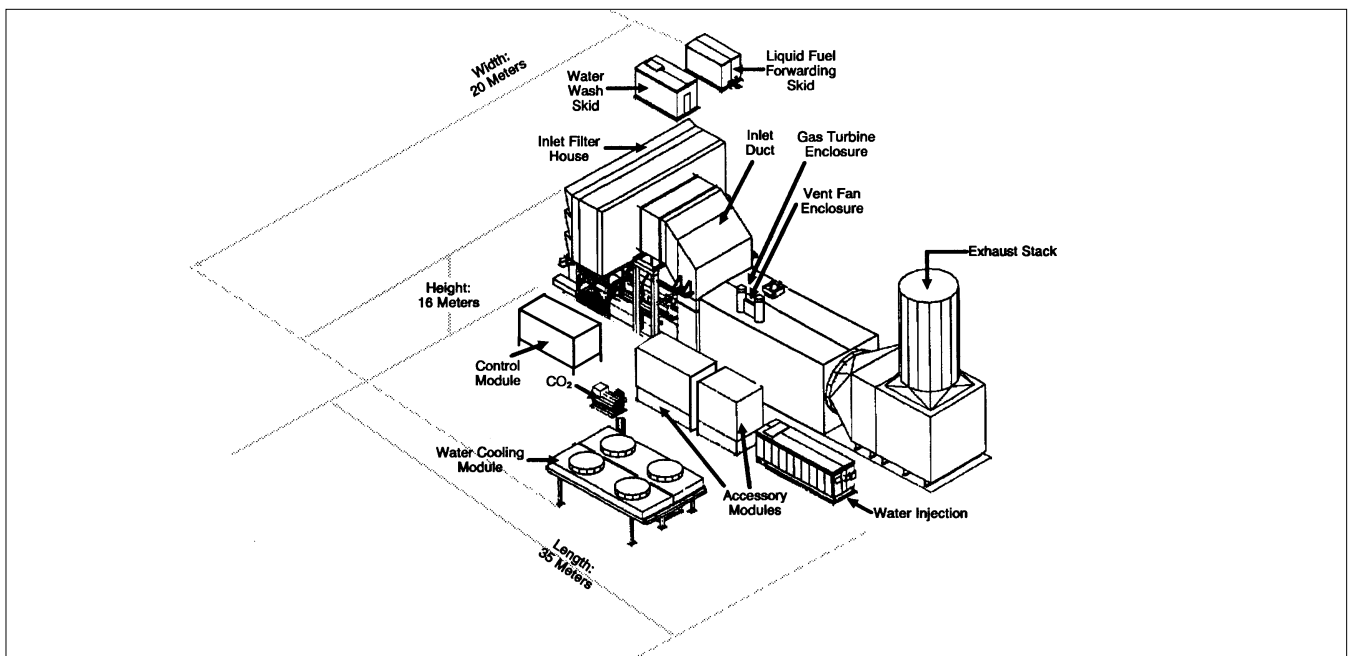

GT25759

Figure 11. Typical general plant arrangement



RDC27664-06

Figure 12a. Assembled stage 1 nozzle segments

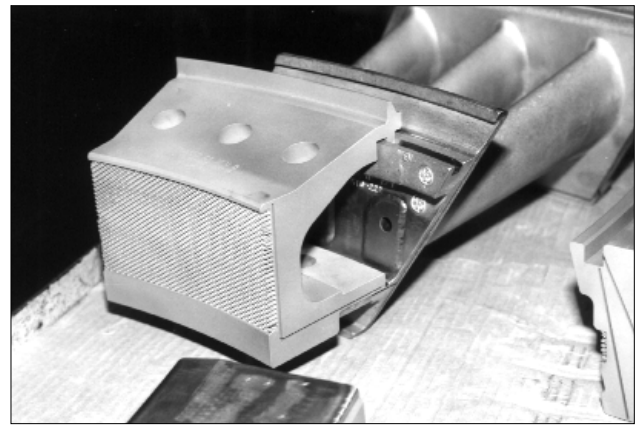

RDC27664-02

Figure 12d. Stage 3 nozzle segments with diaphragm seal



RDC27664-07

Figure 12b. Stage 1 shroud (background); stage 2 shroud (foreground)



RDC27664-04

Figure 12e. Stage 1 nozzle assembly

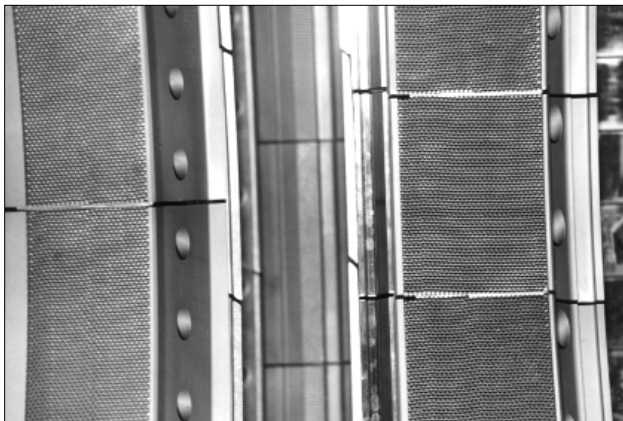

RDC27664-01

Figure 12c. Honeycomb seals on stage 2 and 3 diaphragm seals

mounted on a steel base structure with factory-installed piping and electrical components, similar to the 6B. Side-by-side arrangements are particularly suitable for multiple unit plants. Cooling water needs are secured by external supply (river, sea water with intercooling, etc.) or through fin-

fan coolers. Site civil work can be kept to a minimum with grade-level foundations for installation of all modules and pipeways.

STATUS

Five units are scheduled to be shipped by the end of 1996, two of which are to be in commercial operation by October 1996. Figures 12a through 12h show hardware for these units in various stages of assembly.

Orders as of August 1996 have shown the wide range of both application and customer acceptance of the 6FA design, in both the 50 Hz and 60 Hz markets. The variety of applications covered by these projects, which include combined-cycle, cogeneration and IGCC, fully demonstrate the

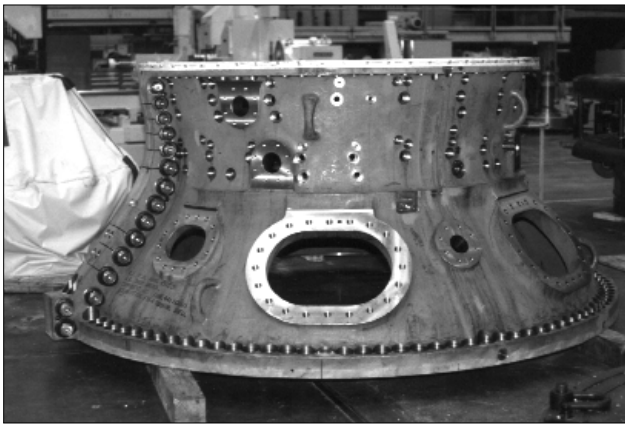

RDC27664-03

Figure 12f. Turbine shell

capabilities of this gas turbine. Combined-cycle applications include both single-shaft and multi-shaft combined-cycle plant configurations. Figure 13 shows the expected fired hours accumulation of these machines over the next three years.

The two launch projects are Destec Cogeneration, a natural-gas-only site (Figure 14) in Kingston, Ontario, Canada, and the Sierra Pacific Power Company's Piñon Pine Power Project, a dual-fuel IGCC site located in Reno, Nevada (Figure 15). Both projects' equipment was shipped in the first quarter of 1996, with mechanical and electrical erection essentially completed in the second quarter and first firing of the units in August. The Destec Cogeneration and the Sierra Pacific Power Projects are both scheduled to be commercial on natural gas in October 1996, with the IGCC portion of the Sierra Pacific Project going on-line in December 1996.

Subsequent projects scheduled to go commercial in late 1996 or 1997 include a cogeneration facility in Finland, a single-shaft base load com-

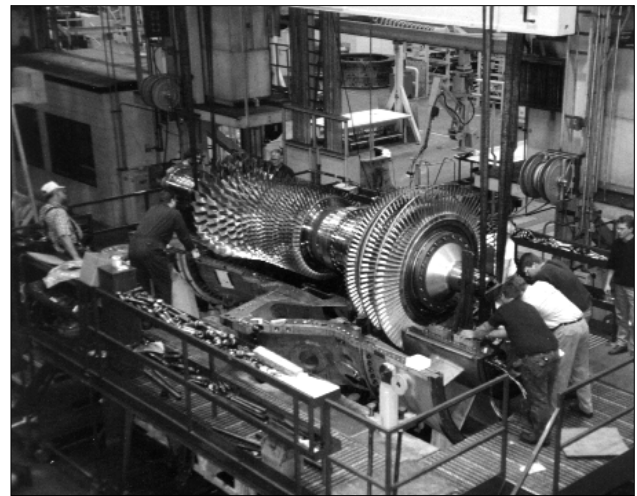

RDC27664-12

Figure 12g. Rotor being installed into unit at Greenville, South Carolina, plant

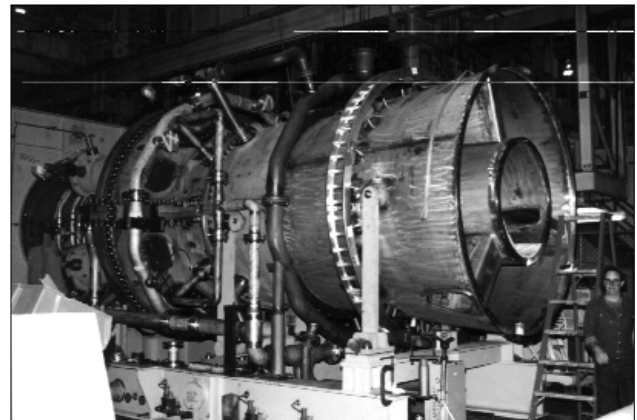

RDC27644-05

Figure 12h. Unit being assembled at Greenville, South Carolina, plant

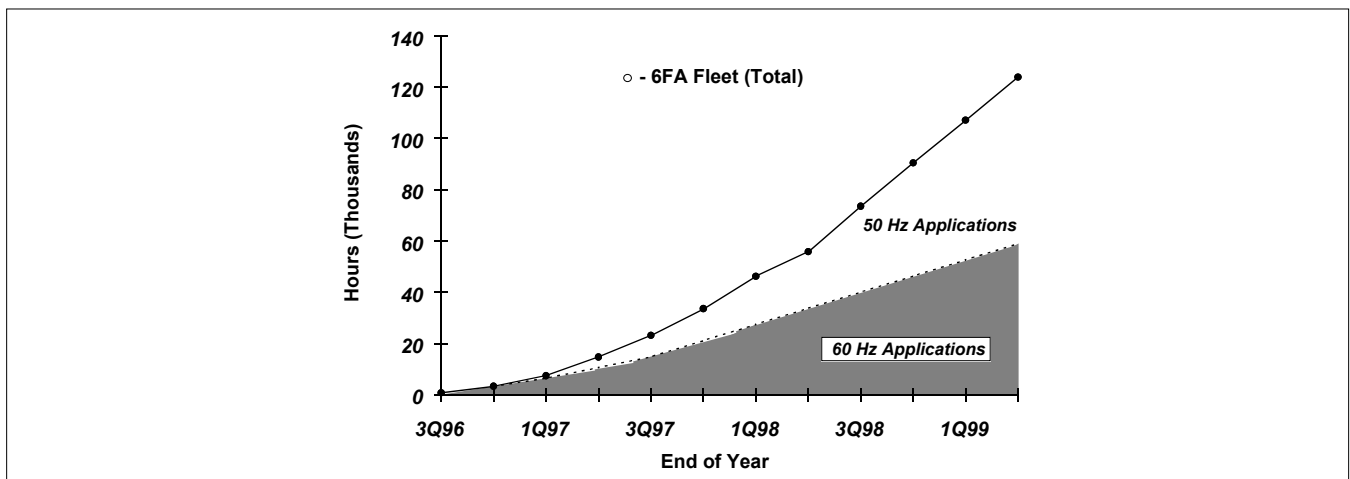

GT25766

Figure 13. 6FA operational experience

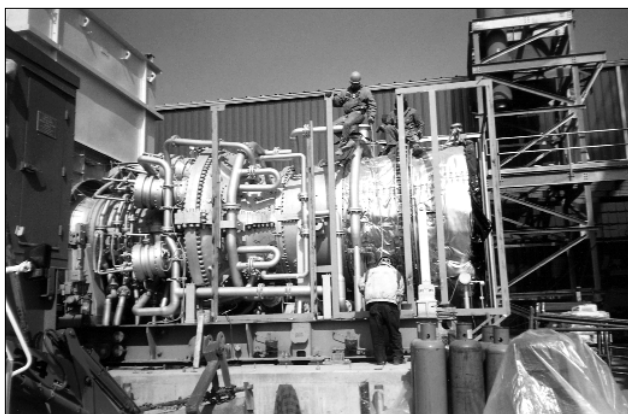

GT25781

**Figure 14. Destec Cogeneration
Kingston, Ontario, Canada**



GT27640-2

**Figure 15b. Sierra Pacific Power Company's
Piñon Pine Power Project**

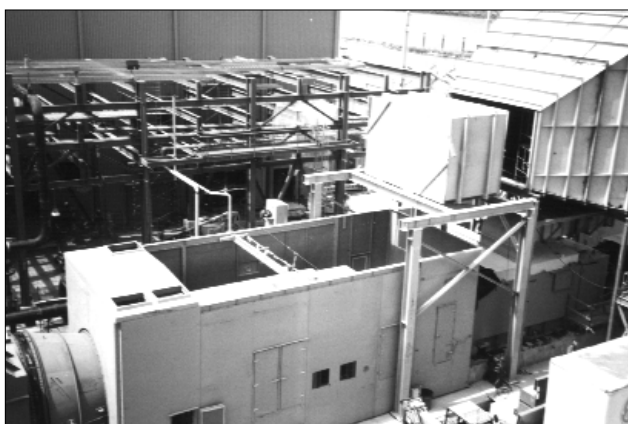

RDC27640-6

**Figure 15a. Sierra Pacific Power Company's
Piñon Pine Power Project**

bined-cycle facility in Italy and a multi-shaft combined-cycle facility in the United States.

The no-load tests on these first three units have successfully demonstrated that the design tools used accurately predicted the operating characteristics of the unit (Table 3). The units exhibited flawless starting and acceleration to full-speed conditions. Rotor vibration levels for these units were well below design criteria and indicated satisfactory stiffness characteristics of the scaled

design. All bolted flanges and shell/casing joints exhibited no leakage.

CONCLUSION

GE's design philosophy, based on a firm analytical foundation and years of experience of gas turbine operation, has resulted in reliable, heavy-duty gas turbines. On this basis, successful designs are carefully scaled to larger or smaller sizes. Scaling has been used to produce similar designs that range from 25 MW to 200 MW. Improved materials and components that have been prudently and carefully applied to increase power and thermal efficiency have resulted in the evolution of proven designs. Finally, designs are carefully tested and demonstrated in extensive development facilities and by fully instrumented unit tests in order to provide full confirmation of the design under actual operating conditions.

Using this methodology, the 6FA has been scaled from the proven 7FA and successfully launched into production. Five units are scheduled to be shipped by the end of 1996, two of which are scheduled to be operational in the same period. The full-speed no-load tests and initial site startup operations of these first units were successful.

**Table 3
6FA TEST RESULTS AT FULL SPEED — NO LOAD**

	ISO Performance Expected (nominal)	ISO Performance as Tested
Airflow (lb/s / kg/s)	437	438
Compressor pressure ratio	10.68	10.74
Compressor efficiency	86.4%	86.2%
Turbine efficiency	84.6%	84.9%
Turbine inlet temperature (F/C)	1074/579	1083/584
Turbine exhaust temperature (F/C)	490/254	495/257

REFERENCES

1. Rowen, W.I., "Operating Characteristics of Heavy-Duty Gas Turbines in Utility Service," ASME paper No. 88-GT-150, presented at the Gas Turbine and Aeroengine Congress, Amsterdam, Netherlands, June 6-9, 1988.
2. "Design of High-Reliability Gas Turbine Controls and Accessories," EPRI Final Report, AP-5823, June 1988.

LIST OF FIGURES

- Figure 1. Typical gas turbine generator arrangement
- Figure 2. GE F product line
- Figure 3. 6FA gas turbine
- Figure 4. Gas turbine configuration
- Figure 5. Growth in compressor design evolution
- Figure 6. Thermal paint verification test for transition piece
- Figure 7. Honeycomb seal locations
- Figure 8. Typical equivalent “thermal mass” to cold flanges at split line
- Figure 9a. Load gear in assembly at Renk AG
- Figure 9b. Load gear in assembly at Renk AG
- Figure 10. Slab-mounted single-shaft arrangement
- Figure 11. Typical general plant arrangement
- Figure 12a. Assembled stage 1 nozzle segments
- Figure 12b. Stage 1 shroud (background) and stage 2 shroud (foreground)
- Figure 12c. Honeycomb seals on stage 2 and 3 diaphragm seals
- Figure 12d. Stage 3 nozzle segments with diaphragm seal
- Figure 12e. Stage 1 nozzle assembly
- Figure 12f. Turbine shell
- Figure 12g. Rotor being installed into unit at Greenville, South Carolina, plant
- Figure 12h. Unit being assembled at Greenville, South Carolina, plant
- Figure 13. 6FA operational experience
- Figure 14. Destec Cogeneration, Kingston, Ontario, Canada
- Figure 15a. Sierra Pacific Power Company’s Piñon Pine Power Project
- Figure 15b. Sierra Pacific Power Company’s Piñon Pine Power Project

LIST OF TABLES

- Table 1. Comparison of gas turbine ratings (ISO, Base, 60 Hz)
- Table 2. 6FA materials
- Table 3. 6FA test results at full speed — no load

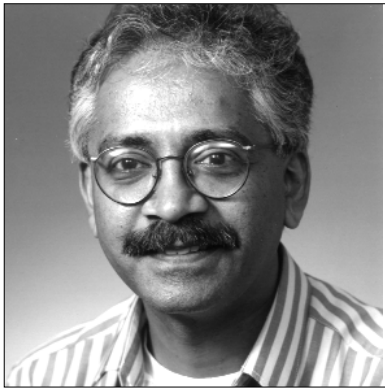

Jay Ramachandran

Jay Ramachandran is currently Manager, 6FA Engineering Programs. He has 18 years of design and project management experience at GE's Power Generation and Aircraft Engine divisions. His engineering experience is primarily in the design of turbine high-temperature components. He also has significant experience gas turbine system design from his contribution to GE's advanced H-generation machines.

Jay graduated from the University of Cincinnati with an MS in engineering. He is also a graduate of GE's ABC gas turbine engineering program. He holds two patents on his work in gas turbine engineering at GE.



Michael C. Conway

Michael Conway has 16 years of power generation experience and is currently Product Line Manager, F Technology. He graduated from Clarkson University with a BS in engineering.