

PERFORMANCE AND RELIABILITY IMPROVEMENTS FOR THE MS5001 GAS TURBINES

Paul C. Daiber
GE Power Systems
Atlanta

ABSTRACT

GE's advances in gas turbine technology are being applied to its operating fleet of MS5001 turbines in the form of uprate and upgrade offerings. MS5001 owners benefit from the opportunity for increased output, reduced NO_x and CO emissions, increased efficiency, extended inspection intervals, improved reliability and operability, and modified exhaust air-flow and exhaust temperature.

The primary offering is the "New-Tech Uprate", which includes the advanced-technology combustion system with the new-technology nozzles and buckets. This uprate package utilizes technology advances as developed for the modern GE fleet of new-unit turbine offerings. It provides customers with the opportunity to increase firing temperature for a substantial gain in output and fuel efficiency, in addition to extended maintenance intervals.

GE continues to develop new products for the established turbine base. Several new products have been developed in the past few years: breach load

- Performance Improvements (Output/Heat Rate)
- Maintenance/Inspection Interval Extensions
- Availability/Reliability Improvements
- Emissions Impact/Regulatory Agencies
- Life Extension
- Thorough Review of Gas Turbine Components and Accessories Systems for Compatibility
- Thorough Review of Load Equipment and Accessories for Compatibility

New Units Technology/Components

Figure 2. Uprate Considerations

fuel nozzles, brush, honeycomb and other seals, DLN-1, Extendor™, and Reuter-Stokes flame detectors.

This document presents the technical description of the MS5001 new-tech uprate and other upgraded hardware offerings.

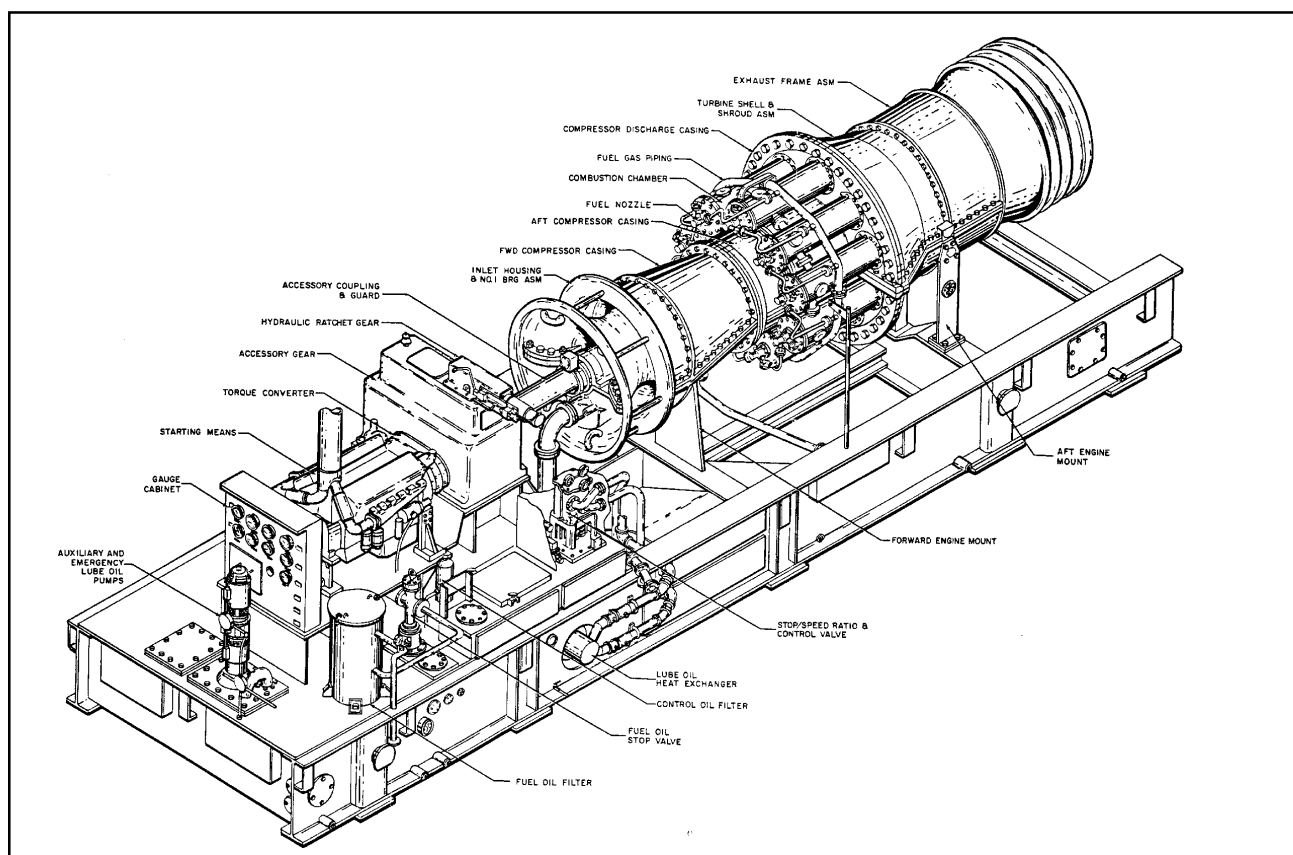

Figure 1. MS5001 Illustration

The MS5001 Turbine Is Built Rugged and Robust

- To Hold Alignment and Roundness, and Survive Minor Mishandling.
- Simple Design for the High Availability Required at Industrial Sites:
 - Low Pressure Ratio, Low Firing Temperature, Low Speed,
 - Simple Combustor, 2 Uncooled Bucket Stages, Stable Casings.
- Design Concept in Service Since 1957 on about 2500 Turbines.
- Inexpensive/Infrequent Parts/Refurbs Compared to High-Tech Turbines.

Big Fleet (>200 as of 1999) of Up-rated MS5001 Turbines

- Continued Parts Availability.
- Performance Enhancement, Extended Maintenance Intervals.
- Previous Investments Made to the Up-rated Turbine Are Retained.

GE is Active in Supporting the Fleet

- Long-Term Service Agreements.
- GE Employs a Dedicated Staff in Most Regions of the World.
- GE Service Shops Are Relatively Close to Most Sites in the World.
- GE pursues the Installed Base Market, Regularly Making Complex modifications to Meet a Customer's Changing Needs.
- GE Can Include Major Items (Beyond Parts and Services) in the Contract.

Get Like-New Performance from the Turbine and its Auxiliaries.
Be Conservative when Planning Power for an Industrial Site or for High Cycle Peaking Power.

Figure 3. Benefits of a Major Overhaul with GE Upgraded Parts

INTRODUCTION

The MS5001 uprates and other pre-engineered offerings continue to be popular in the marketplace as customers improve their equipment and otherwise modify their equipment to meet new demands. The MS5001 turbines (Figure 1), in particular, are typically several decades old, which means they are good candidates for these pre-engineered offerings. Prior to each maintenance outage, it would be useful to review this document to discover if any pre-engineered offerings have become desirable.

The new technology uprate provides customers with the greatest benefits for their turbines. Figure 2 lists the benefits that the customer may consider. The later MS5001 turbine models (MS5001L-R) can have many of the uprated parts substituted into their turbines individually, so that reliability / maintainability benefits can be realized, without the firing temperature uprate.

In addition to the new-technology uprate, GE offers several other pre-engineered offerings for the MS5001, covering every aspect of the turbine's hardware and controls.

GE has organized the pre-engineered offerings into an automated sourcebook, where each offering is given a four-digit code beginning with an "F" (example: FT3M for a 51P N/T uprate). The local GE office has easy access to sourcebook information.

MS5001 turbines remain a good investment even though higher technology turbines are popular in the new unit marketplace. The MS5001 turbine was built simple for dependability, with a low pressure ratio, low firing temperature, only two turbine stages both uncooled, and dimensionally stable turbine casings. The new-technology parts are sufficient for long parts life, yet low enough in manufacturing complexity to be competitively priced and inexpensive to refurbish. Over the several decades of turbine operation, the low cost of new-tech MS5001 parts and refurbish-

ments and the infrequent need for replacement or repair offsets a substantial portion of the fuel savings that would be gained by a simple cycle high performance latest technology turbine. To address the fuel efficiency: the low pressure ratio of the MS5001 turbine makes it compatible with the new technology of reliable regenerators, which improve the MS5001 fuel efficiency to the simple cycle level for latest-technology turbines. The MS5001, and its two-shaft cousins, the MS3002 and MS5002, remains the best economic choice for power in many applications, as shown in Figure 3.

For a continuously loaded gas turbine, heat recovery equipment is a good investment with a typical payback period of a couple of years.

5001 Model	Compressor Stages	Stage 1 Wheel	Stage 2 Wheel Dovetail / Diameter	Hot Gas Path Technology	Stage 2 Buckets	Speed rpm
A-K	16	Old	Old / Large	Pre-Old Tech	Tie-Wire	4860+
L,LA,M	16	New	New / Large	Old Tech	Tie Wire	5100
Mprime	16	New	New / Large	Old Tech	Tip Shroud	5100
M N/T	16	New	New / Large	New Tech	Tip Shroud	5100
R	16	New	New / Small	Old Tech	Tip Shroud	5100
RA (N/T)	16	New	New / Small	New Tech	Tip Shroud	5100
N & P	17	New	New / Small	Old Tech	Tip Shroud	5100
PA (N/T)	17	New	New / Small	New Tech	Tip Shroud	5100

Figure 4. Major Features of Typical MS5001 Turbines

	Pipeline Compression	Chemical Plant Turbines for Compression
Load	Load-Compressors	Load-Compressors, Some with Load Gears
Duty	Somewhat Continuous, Base Load	Continuous Load, Base Load
Site	Unmanned Sites	Unmanned Sites or Manned Industrial Facility
Cycle	Regenerators, No Steam	Regenerators, Boilers, Steam is Available
Fuel	Gas Fuel	Gas Fuel, Dual Gas/Distillate Fuel
Start	Gas Expansion	Gas Expansion and Steam Expansion

	Industrial Electricity Generation	Utility Electrical Generation
Load	Generators with Load Gears	Generators with Load Gears
Duty	Continuous, Base/Peak Load	Daily Cycling / Fast Starts, Seasonal Use, Peak
Site	Manned Industrial Facility	Unmanned Sites or Manned Generation Facility
Cycle	Boilers, Steam is Available	Simple Cycle, No Steam Available
Fuel	Gas, Dual Gas/Distillate	Gas Fuel, Distillate Fuel, Dual Gas/Distillate Fuel
Start	Gas/Steam Exp, Motor or Diesel	Gas Expansion, Motor or Diesel

Figure 5. GE MS3001 and MS5001 Turbines User Profiles

Background of the MS5001 Product Line

The MS5001 product line is GE’s second product line that is still in production (after the MS3002 product line). A quick understanding of the MS5001 evolution will be helpful to the reader who needs to sort through this document to identify only the information that is applicable to a specific turbine model. A summary of the major features of MS5001 turbines is given in Figure 4.

The MS5001, MS5002, and MS3002 turbines were typically applied to continuous duty industrial sites and to peaking duty utility yards, as summarized in Figure 5.

During the first eight years of the MS5001 product line (from pre-MS5001A through MS5001K), the designs changed, sometimes dramatically, from model to model, but the performance was increased only slightly because the firing temperature and the compressor design did not change.

The MS5001L design had advanced materials and other redesigns (such as the cast nodular iron turbine casing) applied to accommodate a higher firing temperature. Minor design improvements continued to be made with the LA and M models, for further improvements in firing temperature.

In 1970, the MS5001 product line was improved by the development of the 17-stage “P-compressor” for the MS5001N model turbine. The MS5001N stage 2 bucket dovetail is located at a smaller radius where it is further from the hot gas path. The MS5001N stage 2 bucket was also redesigned to add a tip-shroud so that the tie-wire could be removed. The MS5001P is very similar to the MS5001N design.

There were customers who did not desire the power of the MS5001N or P, and so the turbine section of the MS5001P was fitted onto the 16-stage “R-compressor” (the original compressor used on MS5001A-M), to create the MS5001R.

In 1987 the hot gas path of both the MS5001P and R turbines was updated and the models were renamed MS5001PA and MS5001RA, respectively. The PA and RA models are called P N/T and R N/T when they are the result of an aftermarket uprate, where “N/T” refers to new-technology. A history of the new-unit models is given in Figure 6.

“Value Package” Offerings

The MS5001A-K turbine offerings are summarized in Figure 7. The MS5001L-M turbine offerings are summarized in Figure 8. The MS5001N-R turbine offerings are summarized in Figure 9.

The MS5001RA and PA turbine offerings are summarized in Figure 10. Figure 11 provides estimates of performance improvement opportunities for MS5001L-M, R turbines. Figure 12 provides estimates of performance improvement opportunities for MS5001N and P turbines.

TURBINE AND COMBUSTION SECTIONS

New Technology Uprate FT3K, FT3L, FT3M

The new technology uprate package converts the combustion and turbine sections into the present production configuration, as introduced in 1987 on new-unit turbines.

The scope of the affected hardware is presented in Figure 13. Figure 14 summarizes the important features of the new hardware. Figure 15 gives a more detailed illustration of the major features of

Model	Ship Dates	kW (NEMA) ⁽¹⁾	Firing Temp (F/C)	Air Flow (10 ³ lbs/hr/10 ³ kg/hr)	Exhaust Temp (F/C)	Heat Rate (LHV) Btu/kW-hr	Efficiency % Btu/hr (LHV)
A	1957-61	10,750	1500/816	662/300	840/449	15,810	21.6
C	1961-64	10,750	1500/816	662/300	835/446	15,810	21.6
D	1961-63	10,750	1500/816	662/300	834/446	15,810	21.6
E	1963	11,500	1500/816	695/315	830/443	15,780	21.6
G	1963-64	12,000	1500/816	695/315	830/443	15,120	22.5
H,J	1964	12,500	1500/816	695/315	820/438	14,430	23.6
K	1965	12,500	1500/816	695/315	820/438	14,430	23.6
L	1966-67	14,000	1600/871	702/318	895/479	14,440	23.6
LA	1968-70	15,250	1650/899	709/322	930/499	14,190	24.1
M	1969-70	16,100	1700/927	716/325	965/518	14,050	24.3
		kW (ISO) ⁽¹⁾					
R	1970-87	19,400	1720/938	767/348	955/513	13,260	25.8
R-N/T	1987-	20,500	1755/957	767/348	970/521	12,780	26.8
N	1970-72	24,600	1730/943	928/421	898/481	12,190	28.0
P	1972-78	24,600	1730/943	938/425	904/484	12,140	28.1
P	1978-86	23,350	1730/943	968/439	901/483	12,020	28.4
P-N/T	1987-	26,820	1765/963	981/445	905/485	11,860	28.7

(1) In early 1970s, Rating Standards Were Changed From NEMA (1000 ft/300m Altitude and 80F/27C) to ISO (Sea Level and 59F/16C) Conditions. To Convert From NEMA to ISO Rating for Approximate Comparison, Multiply NEMA Rating by 1.12. Includes 0/0 Inches H₂O Inlet/Exhaust Pressure Drops. All Ratings Based on Natural Gas Fuel.

Figure 6. MS5001 Performance History

Higher Firing Temperature and Extended Maintenance Intervals ("R" New-Tech Uprate): Adv-Tech Combustion System, with New-Tech S1 Nozzle, S1 Bucket and S2 Nozzle, and Tip-Shroud S2 Buckets
Combustion Mods: Adv-Tech Combustion Liners with Replacement Combustion Casing Adv-Tech Transition Piece with Mod to S1 Nozzle Ring for Mounting Emission Reduction (Diluent Injection, LHE Liners) available with Adv-Tech Comb System Extendor™ Available with the Advanced-Tech Combustion System
Compressor Reduced Camber IGV's at 82 degrees C-450 and GECC1 coated 403SS blades and vanes Water Wash
Maintenance and Operability Enhancements Mark V or Mark VI Control System, Controls Setting Modifications Lube Oil Demister (motor driven blower system) GE Reuter-Stokes Flame Detector System Extended Exhaust Thermocouples
Auxiliary Systems Mods

Figure 7. Summary of Offerings for MS5001 A through K Turbines

the turbine section, and Figure 16 shows how the advanced seal offerings fit into the new-tech uprate. Special climate conditions may require additional hardware modifications, as estimated in Figure 17. A list of new-tech uprate customer sites is given in Figure 18.

The new technology uprate offers an improvement in output power and in heat rate, due to both the improved aerodynamics and the increased firing temperature. The new-technology hardware is more robust compared to original hardware (pre-1987), and offers a substantial maintainability improvement.

Higher NO_x would accompany the increased firing temperature. To counter the higher NO_x level, GE offers the Low NO_x LHE Liner which can be substituted into uprates without any performance penalty.

The load equipment is evaluated with every engineering study of a turbine uprate. Figure 19 shows an example of how control of generator power factor can compensate for the additional output power capability of an uprated turbine.

Other Uprates and Modifications

A turbine that lacks the load equipment capacity for a full new-tech uprate can have an uprate to an intermediate MS5001 model, such as an MS5001M prime, which applies a tip-shroud bucket to the MS5001L-M S2 wheel, and the MS5001R, which requires a replacement S2 wheel on MS5001L-M turbines. A list of conventional parts uprates is given in Figure 20.

Figure 21 provides a list of the items to be reviewed prior to a maintenance outage, so that replacement or improved parts can be planned for. Many part improvements can be performed directly by the GE service shop, rather than being a new part purchase. Figure 22 lists the GE organizations that typically service MS5001 turbines.

Maintainability Improvement

The maintenance interval improvement with a new-tech uprate is illustrated in Figure 23. For a continuous duty natural gas fuel turbine, the hot gas path inspection is eliminated, and the combustion inspections are extended 50%. This is a GE recommendation, and site specific conditions may require a different set of maintenance inspection intervals.

Higher Firing Temperature and Extended Maintenance Intervals (New-Tech Uprate):
Adv-Tech Combustion System, with
New-Tech S1 Nozzle, S1 Bucket and S2 Nozzle, with
Tip-Shroud S2 Buckets, and with New S2 Wheel for the Full “R N/T” Uprate.

Uprate to MS5001R (not New-Tech):
“R” S2 Wheel & Buckets, S2 Nozzle, Other Mods for Firing Temperature Increase.

Uprate to MS5001Mprime (not New-Tech):
Tip-Shroud S2 Bucket with Other Mods for Firing Temperature Increase.

Adv-Tech Combustion and New-Tech Turbine Parts Substitutions:
S1 Bucket, S1 Nozzle and Bucket, S2 Nozzle with Tip-Shroud S2 Bucket

Advanced Seals

High Pressure Packing Brush Seal
S1 Shroud Block Spline and W Seals, S1 Shroud Block Abraidable Coating
S2 Nozzle Diaphragm Brush Seal
S2 Shroud Block Honeycomb Seals

Compressor

Reduced Camber IGV's at 82 Degrees
C-450 and GECC1-Coated 403SS Blades and Vanes
Water Wash

Emissions and Power Augmentation

Low NOx Lean Head End Liner
Steam or Water Injection for NOx, Steam Injection for Power Augmentation

Maintenance and Operability Enhancements

Mark V or Mark VI Control System, Controls Setting Modifications
Extendor™
Shimming for the #2 Bearing (per TIL-413C, Should Be Done at Next Overhaul)
Lube Oil Demister (Motor-Driven Blower System)
Insulation/Corrosion/Erosion Coatings on S1 and S2 Nozzles
GE Reuter-Stokes Flame Detector System
Extended Exhaust Thermocouples, Removable Wheelspace Thermocouples

Auxiliary Systems

Figure 8. Summary of Offerings for MS5001L, LA, and M Turbines

Higher Firing Temperature and Extended Maintenance Intervals (New-Tech Uprate):

**Adv-Tech Combustion System, with
New-Tech S1 Nozzle, S1 Buckets, and S2 Nozzle**

Adv-Tech Combustion and New-Tech Turbine Parts Substitutions:

Liners/X-Fire Tubes, TP's, S1 Bucket, S1 Nozzle and Bucket, or S2 Nozzle

Advanced Seals

**High Pressure Packing Brush Seal
S1 Shroud Block Spline and W Seals, S1 Shroud Block Abradable Coating
S2 Nozzle Diaphragm Brush Seal
S2 Shroud Block Honeycomb Seals**

Compressor

**Reduced Camber IGV's at 85 or 86 Degrees (51N,P)
Reduced Camber Fixed IGV's at 82 Degrees (51R)
Modulating IGV's (for Heat Recovery at Partial Power)
C-450 and GECC1-Coated 403SS Blades and Vanes
51R only: Upgrade Compressor from 16 to 17 Stages
5355 rpm Turbine Speed
Water Wash**

Emissions and Power Augmentation

**Low NOx Lean Head End Liner
Steam or Water Injection for NOx, Steam Injection for Power Augmentation**

Maintenance and Operability Enhancements

**Mark V or Mark VI Control System, Controls Setting Modifications
Extendor™
Upgraded Inactive Thrust Bearing
Shimming for the #2 Bearing (per TIL-413C, Should Be Done at Next Overhaul)
Lube Oil Demister (Motor-Driven Blower System)
Insulation/Corrosion/Erosion Coatings on S1 and S2 Nozzles
GE Reuter-Stokes Flame Detector System
Extended Exhaust Thermocouples
Removable Wheelspace Thermocouples**

Auxiliary Systems

Figure 9. Summary of Offerings for MS5001N, P and R Turbines

Increase the IGV angle to 86 degrees (PA, P N/T)

Advanced Seals Offerings
 Inner Barrel with a High Pressure Packing Brush Seal
 S1 Shroud Blocks with Flexible Spline Seals and a W Spring Seal
 S2 Shroud Blocks and modified or new Stage 2 Buckets for Honeycomb Seals
 S2 Diaphragm with an Interstage Brush Seal
 S1 Shroud Blocks with Abradable Coating

5355 rpm and other controls changes

Power Augmentation and Emissions
 Steam Injection for Power
 Water or Steam Injection for NOx
 Low NOx Lean Head End Combustion Liner
 DLN-1

Extendor™

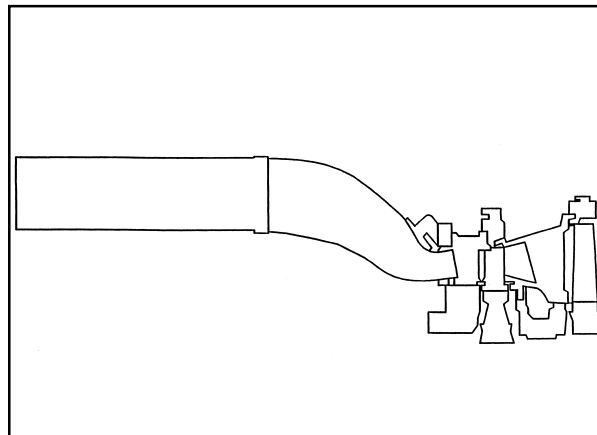

Figure 10. Summary of Offerings for MS5001PA, P N/T, RA and R N/T Turbines

Figure 13. New-Tech Uprate of MS5001, Illustration of Scope

Description	Source Book	Applicable Turbines	Change Output Power%	Change Heat Rate %	Change Exh Temp (F)	Change Firing Temp (F)
Turbine Modifications						
Long-Shank S2B and S2N (R-type) 5001R Uprate		MS5001A-M	4.0	-2.5		none
5001R Uprate	FT3H	MS5001L Generator	16.5	-4.7	68	1600-1720
5001R Uprate	FT3H	MS5001LA Generator	9.9	-3.7	35	1650-1720
5001R Uprate	FT3H	MS5001M Generator	5.5	-3.6	2	1700-1720
5001R New-Tech (R N/T) Uprate	FT3L	MS5001L Generator	22.4	-6.6	82	1600-1755
5001R New-Tech (R N/T) Uprate	FT3L	MS5001LA, M, R Generator	Use Absolute Guarantee Table			
Tip-Shroud S2 Buckets 5001M prime Uprate	FT3D, E	MS5001A-M	1.7	-1.7	-8	none
5001M prime Uprate	FT3J	MS5001L Generator	13.8	-3.0	66	1600-1712
5001M prime Uprate	FT3J	MS5001LA Generator	7.3	-1.9	33	1650-1712
5001M prime Uprate	FT3J	MS5001M Generator	3.0	-1.9	0	1700-1712
5001L New-Tech (L N/T) Uprate	FT3K	MS5001L Generator	13.2	-3.0	60	1600-1712
5001LA New-Tech (LA N/T) Uprate	FT3K	MS5001LA Generator	6.7	-1.9	26	1650-1712
5001M New-Tech (M N/T) Uprate	FT3K	MS5001M Generator	2.4	-1.9	-7	1700-1712
Advanced Seals						
HPP Brush Seal	FS2V	MS5001L-R	0.6	-0.4		ALL NUMBERS ARE ESTIMATES ONLY
Stg 2 Shroud (S2S) Honeycomb	FS2T	cutter teeth bkts	0.4	-0.4		
Stg 1 Shroud (S1S) Block Seals	FS2Y	MS5001L-R	0.5	-0.5		
Stg 2 Interstage (S2D) Brush Seal	FS2Z	New-Tech S2N Only	1.0	-0.5		
Abradable coating on S1S	FS6A	MS5001L-R	not rated	not rated		
IGVs						
Reduce Camber (RC), 82 degrees	FT3I	MS5001A-M, R 82 presently	1.0	-0.3	-1.8	0.9
Reduce Camber (RC), 82 degrees	FT3I	MS5001A-M, R 70 presently	9.3	-2.1	-19.6	8.8
Reduce Camber (RC), 82 degrees	FT3I	MS5001A-M, R 61 presently	23.1	-7.2	-46.4	18.5
NOx Reduction, Perf #'s for 59 F day						
Low NOx Liner	FR1B	MS5001LA-R	0.0	0.0	0	
Water Injection, 2.3 pps, 100 F	FG1A, FR1TMS	5001L-R	3.7	1.7	0	
Steam Injection, 3.3 pps, 600 F	FG1B	MS5001L-R	5.2	-2.8	0	
Less Diluent on More Humid Days, Low NOx Liner reduces the amount of diluent needed.						
Power Augmentation, Perf #'s for a 59 F day, 60% humidity						
5% steam Injection, 10.2 pps, 600 F	FJ3B	MS5001L-R	15.9	-7.6	0	
Evaporative Cooler, 0.29 pps	FD5A	MS5001A-R	2.6	-1.0	0	
P-Compressor						
	FT3F	MS5001R, R N/T	30.9	-7.2	-63	26

Figure 11a. Performance Impact of Offerings for MS5001L, LA, M, R Turbines

Sample Uprate Packages	New and Clean Performance Estimate	Change,		kW	btu/kW*hr
		Output Power %	Heat Rate %		
MS5001L (Original Rating, ISO)	MS5001L	0.0	0.0	15680	14151
MS5001L with Tip-Shroud S2B	MS5001L	1.7	-1.7	15947	13911
MS5001Mprime	MS5001L	13.8	-3.0	17844	13727
MS5001M N/T	MS5001L	13.2	-3.0	17750	13727
MS5001L with MS5001R style S2B and S2N	MS5001L	4.0	-2.5	16307	13797
MS5001R	MS5001L	16.5	-4.7	18267	13486
MS5001R N/T	MS5001L	22.4	-6.6	19192	13217
MS5001LA (Original Rating, ISO)	MS5001LA	0.0	0.0	17080	13906
MS5001LA, RC IGV's, HPP brush seal, tip-shroud buckets		3.3	-7.6	17649	12853
MS5001M (Original Rating, ISO)	MS5001M	0.0	0.0	18032	13769
MS5001M with MS5001R style S2B and S2N	MS5001M	4.0	-2.5	18753	13425
MS5001R N/T with RC IGV's	MS5001LA, M, R	0.0	0.0	19800	13250
MS5001R N/T with All Adv Seals and RC IGV's		2.5	-1.8	20299	13013
MS5001R N/T with All Adv Seals, RC IGV's, with 2.3 pps of Water Injection		6.3	-0.1	21051	13234
MS5001R N/T with All Adv Seals, RC IGV's, with 3.3 pps of Steam Injection		7.9	-4.5	21355	12649
MS5001R N/T with All Adv Seals, RC IGV's, with 10.2 pps of Steam Inj		18.8	-9.3	23527	12024
MS5001R N/T with P-Compressor		30.9	-7.2	25908	12296
MS5001R N/T with P-Compressor, All Adv Seals with 13.2 pps of Steam Inj		56.3	-16.9	30945	11013

All Numbers are for Illustration Purpose Only.

Site Conditions and Turbine Configuration Specifics Need to be Factored In by GE Engineering.

Figure 11b. Examples of Performance Impact for MS5001L, LA, M and R Turbines

Description	Source Book	Applicable Turbines	% Output	% Heat Rate	
Turbine Modifications					
5001P New-Tech (P N/T) Uprate	FT3M	MS5001N, P	Use Absolute Guarantee Table		
Advanced Seals					
HPP Brush Seal	FS2V	MS5001N, P	0.6	-0.4	ALL NUMBERS ARE ESTIMATES ONLY
Stg 2 Shroud (S2S) Honeycomb	FS2T	cutter teeth bkts	0.4	-0.4	
Stg 1 Shroud (S1S) Block Seals	FS2Y	MS5001N, P	0.5	-0.5	
Stg 2 Interstage (S2D) Brush Seal	FS2Z	New-Tech S2N Only	1.0	-0.5	
Abraidable coating on S1S	FS6A	MS5001N, P	not rated	not rated	
IGVs					
Reduce Camber (RC), 85 degrees	FT3C	MS5001N, P, pre 1978	3.7	-0.3	
Reduce Camber (RC), 86 degrees	FT3C	MS5001N, P, pre 1978	3.9	-0.2	
Reduce Camber (RC), 85 degrees	FT3C	MS5001N, P, post 1978	1.7	-0.6	
Reduce Camber (RC), 86 degrees	FT3C	MS5001N, P, post 1978	1.9	-0.5	
NOx Reduction, Perf #'s for 59 F day					
Low NOx Liner	FR1B	MS5001N, P	0.0	0.0	
Water Injection, 3 pps, 100 F	FG1A,FR1T	MS5001N, P	3.9	1.9	
Steam Injection, 4.3 pps, 600 F	FG1B	MS5001N, P	5.4	-3.2	
Less Diluent on More Humid Days, Low NOx Liner reduces the amount of diluent needed.					
Power Augmentation, Perf #'s for a 59 F day, 60% humidity					
5% steam Injection, 13.2 pps, 600 F	FJ3B	MS5001N, P	16.5	-8.8	
Evaporative Cooler, 0.37 pps	FD5A	MS5001N, P	2.6	-1.0	
Sample Uprate Packages					
New and Clean Performance Estimate			kW	btu/kW*hr	
MS5001P N/T (Pre 1978 Ship) with 85 degree RC IGV's			25240	12430	
MS5001P N/T Uprate with 86 deg RC IGV's, HPP BS, and S1S Adv Seals			1.3	-0.8	25568 12331
above with S2D brush seal			2.3	-1.3	25823 12269
P N/T with All Adv Seals and 86 IGV's and with 3 pps of Water Injection			6.7	0.2	26938 12452
P N/T with All Adv Seals and 86 IGV's and with 4.3 pps of Steam Injection			8.3	-4.8	27327 11829
P N/T with All Adv Seals and 86 IGV's and with 13.2 pps of Steam Injection			19.7	-10.3	30204 11145

Power and Heat Rate Numbers are for Illustration Purpose Only.

Figure 12. Performance Impact of Offerings for MS5001N, P Turbines

A/T Combustion Liners:

TBC coated *for mitigated temperature distribution and 100 F cooler metal temperature.*
 Splash plate cooling *around the crossfire tube collars*
 Low NOx LHE Liners *are available as an option (FR1B)*

A/T Cross Fire Tubes:

Swirl Cooling Holes *for cooler metal temperature.*
 Hardfacing *is available as an option, FR1N.*

A/T Transition Pieces:

Hastelloy-X material *for improved stress limits.*
 Floating inner seal with new side seals and increased corner radii on the aft frame
 Cylinder Mount *for the aft bracket reduces cracking.*

N/T S1 Nozzle: Requires that new-tech S1 Buckets be installed.

Two Vanes per Segment *for less cracking due to uneven thermal growth.*
 Increased Wall Thickness.
 New Trailing Edge Cooling Holes *reduce training edge metal temperature 70 F.*
 More Efficient Airfoil Design.

N/T S1 Bucket:

GTD-111 Equiaxed Material *rather than In 738, for a longer creep life.*
 GT-33 Overlay Coating *provides better protection than the PtAl diffusion coating.*
 Solid Bucket Construction *resists foreign object damage compared to the hollow In 738 buckets.*

S1 Shroud Blocks: Requires replacement when new-tech S2N is installed
 Inter-segment Cloth Seals *are available as an option, FS2Y.*

N/T S2 Nozzle: Requires on-site machining for pins and removable wheelspace thermocouples
 Four Vanes per Segment *for crack resistance caused by thermal cycling.*
 FSX-414 rather than N-155, *for strength and creep deflection resistance*
 Supported by the Shroud Blocks *for minimized out-of-roundness*
 Diaphragm Brush Seal *is available as an option, FS2Z*
 Removable Wheelspace Thermocouples are included

S2 Buckets: S2 Buckets only replaced when uprating MS5001A-M to N/T

Tip Shroud Buckets *replace tie-wire buckets. New S2 Wheel for Uprate to MS5001R N/T*
 Long Shank Buckets *replace short shank buckets with uprate to MS5001R N/T from L, LA, or M.*
 Cutter Teeth *would be included with the optional honeycomb seal FS2T.*

S2 Shroud Blocks: Requires replacement when new-tech S2N is installed
 Honeycomb Seal *is available as an option, FS2T*

Associated Hardware Changes:

Reuter-Stokes Ultraviolet Flame Detectors *are Recommended, FK5J.*
 #2 Bearing Mod to shim and to add a Flex Pipe *is Recommended if Applicable, FS1D.*
 Inactive Thrust Bearing Mod on MS5001N,P turbines *is Recommended if the Rotor is in the Shop*
 Extended Exhaust Thermocouples *are a recommended option, FK5B.*
 Reduced Camber IGV's *are a recommended option, FT3I or FT3C.*
 HPP Brush Seal *is available as an option, FS2V*
 MS5001A-K and other early-model turbines require more extensive secondary changes.

Figure 14. New-Tech Uprate of MS5001, Package Description

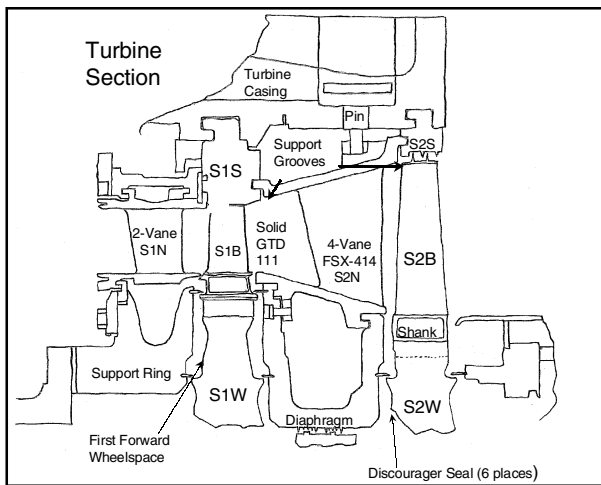

Figure 15. New-Tech Uprate of MS5001 Illustration of Turbine Section

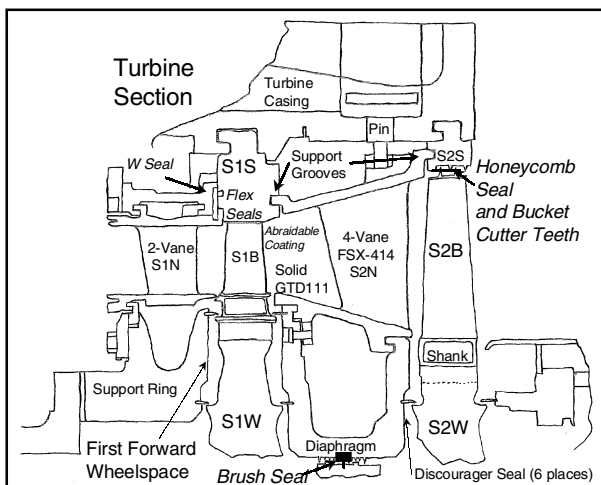

Figure 16. New-Tech with Advanced Seals Uprate of MS5001, Illustration of Turbine Section

Refer to GER 3620G for GE recommendations on modifications based on operating and site conditions.

For a peaking duty MS5001 turbine typical of the utility industry, the inspection intervals are based on the number of start cycles. The 24000-hour hot gas path inspection corresponds to 1200 starts. For this type of duty, the hot gas path inspection is not eliminated due to a lack of field data on the new-tech stage 1 bucket performance.

The maintenance interval reduction as recommended by GE requires that the full new-tech uprate package be purchased. Many of the maintenance benefits can be realized by purchasing only select new-tech parts. In particular, if a turbine is being uprated to an old-tech MS5001 model, then the choice must be made as to what new-tech parts are more important to include, if any. For example, an MS5001A-M turbine being uprated to an MS5001R

MS5001 Model	Uprate	Reason	Primary Hardware Affected	Climate
A-M	R or N/T	Exhaust Temperature Increase	Exhaust Frame Diffuser	Hot
L-someM	R or M	S1 Nozzle Cooling Capability	Nozzle Mod or Replacement	All
A-M, R	P-compr	Increased Starting Torque	Starter Modification	All
A-M,R	P-compr	Shaft Limited to 29.4 MW	Stage 2 Wheel for 31.5 MW	Cold
L-M,R	R N/T	Higher Compr Disch Pressure	Compressor Discharge Casing	Cold
L-M,R(old)	P-compr	Higher Compr Disch Pressure	Compressor Discharge Casing	Cold
L-M,R(old)	P-compr	Higher Compr Disch Pressure	Turbine Casing	Cold
L-M	P-compr	Shaft Change for 31.5 MW	#2 Bearing	Cold
N, P	RC IGV's	Flow Instabilities	Inlet Scroll, Actuation Hardware	Cold
N, P	P N/T	Losses due to Radial Struts	Exhaust Frame with Rotated Struts	Cold
N, P	P N/T	Shaft Limited to 29.4 MW	Stage 2 Wheel for 31.5 MW	Cold
N, P (old)	P N/T	Higher Compr Disch Pressure	Compressor Discharge Casing	Cold
N, P (old)	P N/T	Higher Compr Disch Pressure	Turbine Casing	Cold
A-R	Any	Torque Limited	Load Coupling	Cold
A-R	Any	Torque Limited	Load Gear	Cold
A-R	Any	Generator kVA Limited	Generator Mod	All, Cold

*"Cold" refers to Arctic Regions

Figure 17. MS5001 Uprates, Hardware Affected by Climate

Location	Model	Application	# Units	Location	Model	Application	# Units
Florida	5001P	Generator Drive	1	Alaska	5001R	Mechanical Drive	13
Bahrain	5001LA	Generator Drive	2	Massachusetts	5001R	Generator Drive	1
Holland	5001LA	Mechanical Drive	2	Puerto Rico	5001P	Generator Drive	15
Holland	5001N	Generator Drive	1	Caribbean	5001LA	Generator Drive	4
Holland	5001LA	Generator Drive	2	Caribbean	5001M	Generator Drive	3
Nigeria	5001P	Generator Drive	3	Caribbean	5001P	Generator Drive	2
Bahamas	5001P	Generator Drive	2	Louisiana	5001M	Mechanical Drive	1
Thailand	5001LA	Generator Drive	1	Holland	5001P	Generator Drive	2
Venezuela	5001P	Generator Drive	13	Mississippi	5001LA	Generator Drive	2
Norway	5001M	Mechanical Drive	4	Mississippi	5001M	Generator Drive	2
Indonesia	5001P	Generator Drive	3	North Sea	5001M	Generator Drive	3
Louisiana	5001K	Mechanical Drive	1	North Sea	5001P	Generator Drive	3
Egypt	5001P	Generator Drive	20	Venezuela	5001M	Generator Drive	1
Venezuela	5001L	Generator Drive	1	Puerto Rico	5001P	Generator Drive	9
North Carolina	5001P	Generator Drive	8	Puerto Rico	5001LA	Generator Drive	1
Pennsylvania	5001A	Mechanical Drive	2	Algeria	5001P	Generator Drive	6
Texas	5001P	Generator Drive	1	Bolivia	5001P	Generator Drive	1
California	5001R	Generator Drive	1	Argentina	5001P	Generator Drive	2
Jamaica	5001P	Generator Drive	2	El Salvador	5001P	Generator Drive	3
Pakistan	5001P	Generator Drive	2	Honduras	5001P	Generator Drive	1
Total							147

Figure 18. List of New-Tech Uprate MS5001 Turbines (up to 1995)

configuration would have enhanced maintainability if the new-tech S2 nozzle replaces the conventional S2 nozzle of the “R” uprate package.

A GE service shop offers further maintainability improvements by the use of insulative/corrosion/erosion coatings on refurbished nozzles, and by the use of hard coatings on the combustion hardware.

Stage 1 Nozzle (S1N) FT3R

The new-tech S1N design has many major differences from the previous designs: a new aerodynamic airfoil design, a new cooling hole configuration, and improved component mechanical design. See Figure 24.

The new-tech design has two vanes per segment rather than five vanes per segment as on the old-technology parts. Two vane segments have balanced thermal growth, for a greater resistance to sidewall cracking caused by cyclic thermal loading. Experience shows a three-to-one improvement in cycles-to-crack initiation compared to the five vane per segment design.

The new design increases wall thickness up to 50% to improve creep ballooning cracking. In addition, trailing edge cooling holes are repositioned to

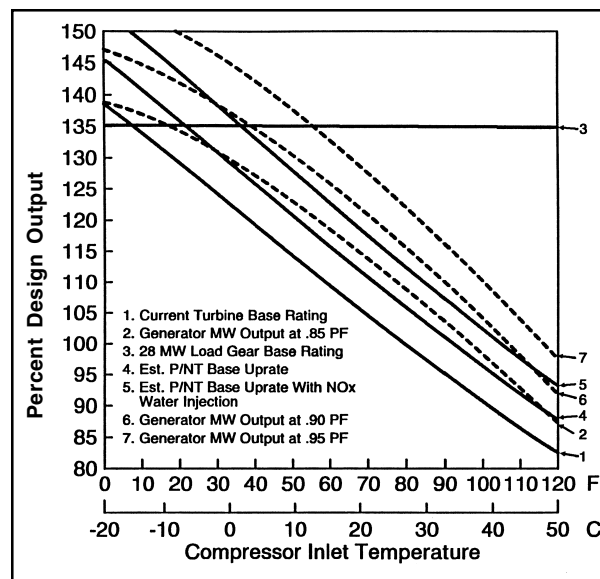

Figure 19. Typical MS5001P N/T Performance Study Showing Load Limits

reduce trailing edge metal temperatures by as much as 70 F, which reduces trailing edge cracking.

The new-tech S1N material remains FSX-414, which is the typical S1N material across all turbine product lines.

<p><u>Rotor On Site</u> Hand Scrubbing or CO2 Blasting of Blades and Vanes GECC-1 on Blades and Vanes New-Tech S1 Buckets Tip-Shroud S2 Buckets (needs new S2S Blocks and possible new S2 Wheel)</p> <p><u>Rotor Goes to GE Service Shop</u> Thrust Collar Mod for Compatibility with Upgraded Inactive Thrust Bearing Wheel Inspections S16 Wheel Replacement C-450 for First Two Stages of Blades and Vanes GECC-1 on Bladed Wheels GECC-1 on Turbine Section Buildup/Coat Wheel Rims to Re-establish 8-18 mil gap</p> <p><u>Combustion Inspection</u> Adv-Tech Liners, X-fire Tubes, and/or Transition Pieces Low-NO_x Liner Extendor™ Mods, TBC or TBC bond coat on Liner and/or Transition Pieces, Anti-Rotation Feature for X-fire Tubes Transition Piece Mod to add Floating Seal Regen: Replace TP Seal Rings at Wall to eliminate gap</p> <p><u>Inlet/Exhaust</u> Self Cleaning or Multi-Stage Inlet Filters Evaporative Cooler Repair to Exhaust Plenum Insulation Refurbishment, Reskinning, or Replacement of Exhaust Frame Heat Recovery Equipment (Regen, HRS, Process Oil Heater, Economizer)</p>	<p><u>Nozzle Refurbishments at GE Shop</u> TBC Coating</p> <p><u>Casing on Site</u> New-Tech S1 Nozzle (needs new-tech S1 Buckets) New-Tech S2 Nozzle Advanced Seals version of S1S Blocks, Abridable Coating on S1S Blocks Coating to Tighten the Looseness of the Shroud Block Hook Fits Patch Ring for Damaged Hook Fit, or for the Possibility of Damaging the Hook Fit High Pressure Packing Brush Seal #2 Bearing Shim and Flex Pipe Kit Borescope Hole Machining Removable Wheelspace Thermocouples Extended Exhaust Thermocouples Reuter-Stokes Flame Detectors Reduced Camber IGV's SSS Clutch for Starter Dry Diaphragm Accessory or Load Couplings Replacement Horizontal and Vertical Bolts, S1N High Temp Bolts</p> <p><u>Station Auxiliaries</u> Health of Station Battery Health of Fuel Forwarding System Gas and Liquid Fuel Control Valves Fire Protection System Turbine Lagging Quality of Lube Oil Quality of Fuel Delivery and Storage to Prevent Contamination</p>
--	---

Figure 21. Items for MS5001 Maintenance Outage

Local GE Sales Office - The First Customer Contact

Atlanta Parts Center, Engineers and Project Managers, I&RS, I&FS, etc.

Service Shops, I&RS - Located World Wide, Services Include:

Nozzle Repair, Bucket Repair and Bucket Heat Treat, Inspections
 Fuel Nozzle Machining, Flow Checks, and Matching
 Combustion Liner Repair/Modifications and Flow Checks/Matching, Extendor™
 Rotor Rebuilding and Refurbishment, Journal Machining
 Casing Machining and Rebuilds, Complete Turbine Rebuilds (3000 & 5000)
 Coatings: Insulation / Erosion / Wear / Corrosion / Build-Up / Abraidable,
 Coatings: Nozzles / Buckets / TP's / Liners / Compressors / etc.

TA Services, I&FS (On-Site GE Engineering Assistance)

Field Project Managers (Turnkey Projects), Start-up Engineers, Labor and Tools,
 Mechanical and/or Electrical Engineer Expertise, Specialized Tools

Nuovo Pignone (Wide Variety of Power Systems Products)

Regenerators, Turnkey Simple to Regen Cycle Conversions
 New Turbines and Compressors for Industrial Applications
 Load-Compressor Upgrades, Heat Exchangers and other Exhaust Equipment

On-Site Machining (Technical Specialist / Specialized Tooling)

Alignment Diagnosis and Resolution, Casing Modifications, Flange Leak Keys

GE Power Systems Energy Consulting - All Plant/Grid Electrical System Issues

Figure 22. GE Organizations that Service MS5001 Customers

	MS3002 H to J (FT1B)	MS5001 LA to R (FT3H)	MS5001 16 to 17 Stage Compressor (FT3F)	MS5001 M' (FT3J)	Total
1984	4	1	-	1	6
1985	5	-	-	1	6
1986	-	3	-	3	6
1989	-	2	1	-	3
1990	-	1	13	-	14
1991	4	1	1	2	8
1992	-	1	-	1	2
1993	3	3	-	5	11
1994	-	2	1	1	4
Total	16	14	16	14	60

Figure 20. List of Conventional Parts Upgrades

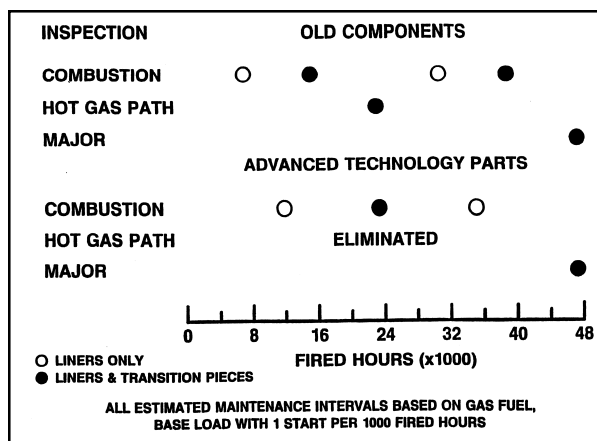

Figure 23. New-Tech MS5001 Maintenance Interval Improvement

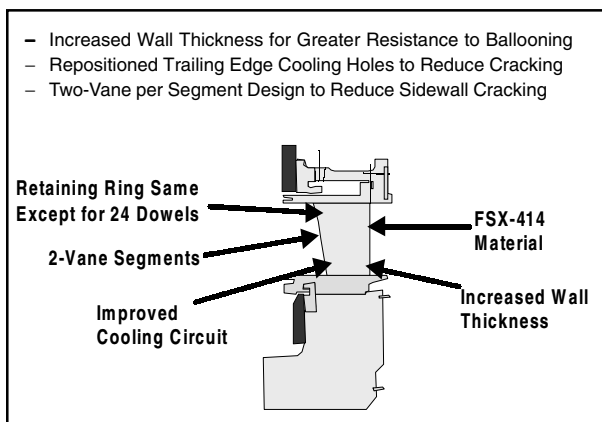

Figure 24. New-Tech MS5001 S1 Nozzle

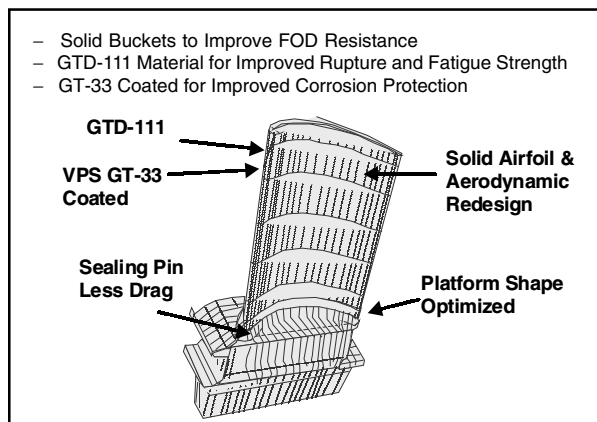

Figure 25. New-Tech MS5001 S1 Bucket

The new-tech S1 nozzle cannot be used with the old-tech (conventional) stage one bucket because of a potential S1 bucket resonance due to the change in S1 nozzle vane count. The new-tech S1 nozzle must be installed with a new-tech S1 bucket.

Stage 1 Bucket (S1B) FT3R

The new-tech first-stage bucket is more aerodynamically efficient, more corrosion/oxidation resistant and mechanically stronger, compared to the old-tech design. See Figure 25.

The new-tech S1B material, equiaxed GTD-111, has increased rupture strength and improved low cycle fatigue properties compared to IN-738. The stronger and less thermally sensitive GTD-111 permits the bucket design to be solid, which improves resistance to foreign object damage (FOD) compared to the hollow IN-738 bucket design.

The GTD-111 bucket is coated with GT-33, a vacuum plasma spray overlay coating that greatly increases both the corrosion and oxidation resistance of the bucket. GT-33 has better performance than the PtAl diffusion coating typically applied to the old-tech IN-738 buckets. Refer to GER-3569F “Advanced Gas Turbines, Materials and Coatings” for more information.

The new-tech stage one bucket can be installed with either a new-tech or an old-tech stage one nozzle. A full set of new-tech S1Bs can be directly substituted into an MS5001L-R turbine.

Stage 2 Nozzle (S2N) FT3S (M N/T), FT3T (R, P N/T)

The new-tech stage two nozzle has four vanes per segment to reduce cracking caused by thermal cycling, as compared to the old-tech 180 degree segment design. The segmented S2N design is typical across the present production of turbine product lines. See Figure 26.

The new-tech S2N material was upgraded to FSX-414 to increase strength and creep resistance, compared to the N-155 alloy used in the old-tech S2N design.

The new-tech S2 nozzle sections are supported by the first and second stage shroud blocks, which helps to minimize out of roundness. The diaphragm interstage packing is permanently aligned to its respective nozzle segment, assuring a proper alignment of packing to the rotor, and simplifying alignment during nozzle installation.

By using the modern design analysis tools, the new-tech nozzle was given a more aerodynamically efficient vane design.

For the installation of the new-technology S2 nozzle, modifications to the turbine shell are required.

The modification includes new first and second stage shroud blocks that have a support groove for the new nozzle arrangement. On-site machining of the casings is required for the nozzle pins and for the removable wheelspace thermocouples. GE I&FS and GE on-site machining maintain sets of the specialized tooling in the Houston Service Shop warehouse, and it is critical that this tooling be used.

The new-tech S2 nozzle is only available for turbines that have the tip-shroud S2 buckets. For an MS5001L, LA, or M turbine the conversion to a new-tech S2 nozzle requires several features to be included: (a) S1 shroud and S2 shroud blocks, (b) tip shroud S2 buckets, (c) machining for the S2 nozzle pins, removable wheelspace thermocouples, borescope holes, and S2 shroud block radial pins, and (d) in addition, a S2 wheel for long shank S2 buckets is recommended and may be required due to the speed restriction.

It is recommended for performance that the replacement S1 shroud blocks have the W-seal and flexible spline seal features, and, if new S2 buckets are being purchased, that the replacement S2 shroud blocks have the honeycomb seal features.

The S2 nozzle (either old-tech or new-tech) comes in two types, one for the long-shank S2 bucket (FT3T for R and P N/T design), and one for the short-shank S2 bucket (FT3S for M N/T design). The short-shank bucket version of the S2N has substantially less flow area, as necessary to provide the correct S1 and S2 work split, for both the tie-wire and tip-shroud versions of the short-shank bucket. The long-shank version of the S2N/S2B set has a substantial performance benefit over the short-shank S2N/S2B hardware. The recommendation is to purchase an “R” S2 nozzle with the long-shank S2 buckets.

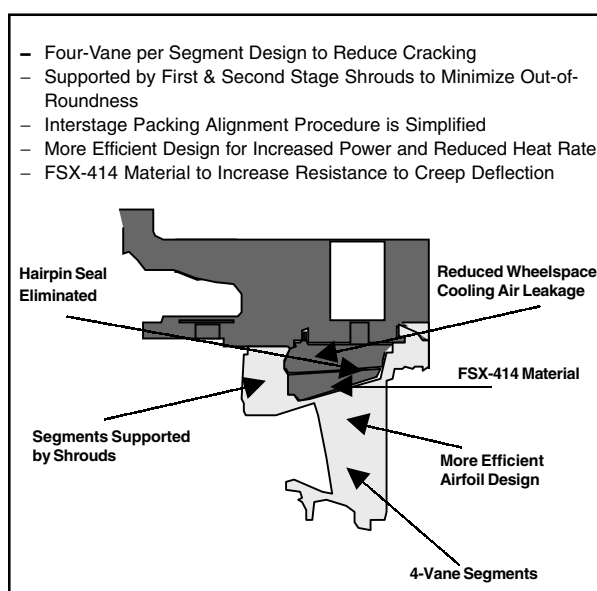

Figure 26. New-Tech MS5001 S2 Nozzle

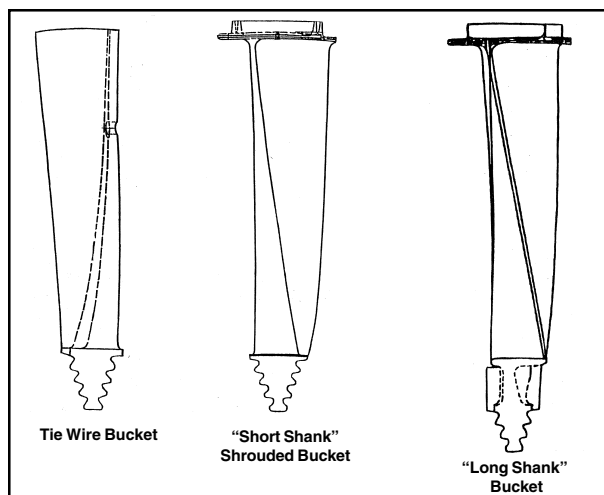

Figure 27. MS5001 S2 Bucket Comparison Illustration

Turbine Model	Compressor Type	rpm When Sold	rpm Range	(Notes)
MS5001A-M, original S2 bucket	16	4860 or 5100	3888 to 5100	
MS5001A-M, tip-shrd short-shank S2B	16	4860 or 5100	4650 to 5100	(1)
MS5001L-M, prime and N/T	16	4860 or 5100	4650 to 5100	(1)
MS5001L-M, long-shank S2B	16	4860 or 5100	3888 to 5100	
MS5001R (IN-738 S1B only)	16	4860 or 5100	3888 to 5355	(2)
MS5001PA and R N/T	16	4860, 5100, or 5355	3888 to 5355	(2,3)
MS5001N and P (IN-738 S1B only)	17	5100	4692 to 5355	(2)
MS5001PA and P N/T	17	5100 or 5355	4692 to 5355	(2,3)

(1) The shrouded no-shank stage 2 bucket had HCF vibration cracking on some load-compressor applications due to operation below 4600 rpm.
 (2) The number of starts is restricted to 10 per year if the speed range is permitted to extend above 5100 rpm.
 (3) The MS5001 P N/T and R N/T turbines (GTD-111 S1B) require a 25 F reduced firing temperature if the turbine is permitted to operate above 5100 rpm.

Figure 28. Speed Ranges of MS5001 Turbines

Stage 2 Buckets (S2B) FT3D, FT3E

The latest technology S2B has (a) a tip shroud for vibration damping and performance, (b) platform seal pins for vibration damping to better handle speed variations, (c) a dovetail further from the hot gas path for higher firing temperatures, (d) cutter teeth for compatibility if there is a honeycomb seal, and (e) is made from IN-738 which is stronger than the U-500 used previously.

This latest technology S2B is supplied on MS5001A-M turbines that are uprated to the MS5001R N/T configuration. This latest technology S2B has a shank, and so requires that the MS5001A-M turbines receive a new S2 wheel for the uprate. As an alternative a tip-shroud bucket has been developed for the MS5001L-M turbine wheel (called the "tip-shroud short-shank S2 bucket") as illustrated in Figure 27; however without the shank it cannot have the platform vibration damping, and so has speed limitations, as presented in Figure 28. (Another limitation: any short-shank S2B used with a firing temperature above 1662 F, requires dovetail impingement cooling air.) The "tip-shroud short-shank S2 bucket" is best applied to the constant speed generator drive turbines, where it is proven by ten years of operation to have no problems with vibration.

See Figure 29 for a summary of benefits of S2 bucket upgrades.

Benefits of Tip-Shroud Buckets

Substantial Fuel Efficiency and Power Output Improvement
 Extended Bucket Life due to Better Tip Damping, no More Random Failures at the Hole
 Opportunity for Honeycomb Seal, New-Tech S2 Nozzle, Slightly Higher Firing Temperature

Benefits of the Long-Shank over the Short-Shank Tip-Shroud Buckets

A Field Proven Product that Has Been on New & Modified Turbines for Over 25 Years.
 Rotor Speed May Go Below the Short-Shank Tip-Shroud S2B Minimum Speed of 4650 rpm.
 Less Bucket Vibration due to Damping at the Platform by Use of Seal Pins.
 Opportunity for Higher Firing Temperature and 5355 rpm
 Long-Shank Buckets Will Be Kept in-Stock, but Short-Shank Typically Will not (due to Fleet Size)
 The Better In-738 Material for Long Shank Buckets (U-500 Material for Short-Shank)
 Long-Shank Buckets Are Cast with Cutter Teeth and so Are Compatible with Honeycomb without Welding

Note: Long-Shank Buckets Require a Replacement of the S2 Wheel.
 Performance Is Further Enhanced if the Long-Shank (MS5001R) Version of the S2 Nozzle Is Included.

Tip-Shroud Buckets Require a Change Out of the Horizontally Doweled Lower Half Shroud Blocks.
 Realignment due to Exhaust Frame Removal, Required to Remove Horizontal Dowels from Lower Half.
 Requires Machining of the Turbine Casing to Install Radially Doweled Shroud Blocks.
 GE I&FS Has Specialized Tooling to Simplify this Process as an on-Site Machining Operation.
 Request Borescope Holes Be Included as Part of the Casing Machining so that Proper Tooling Is Brought.

Note: Load-Compressor Drive Turbines Should not Consider Short-Shank Tip-Shroud Buckets due to Their Requirement for Variable Speed. Generator Drive Turbines Have Typically not Experienced Vibration Problems With Short-Shank buckets, and Have Had Over 10 Years of Service.

Figure 29. Benefits of MS5001 Long-Shank S2 Bucket

The Advanced-Technology Combustion System

The combustion system consists of combustion liners, cross fire tubes, and transition pieces. The advanced-technology version of all these items must be installed for (a) the combustion inspection interval extension recommendation, (b) for diluent (steam or water) injection for NO_x reduction, (c) for a firing temperature uprate, or (d) for the full Extendor™ kit offering (FR1V).

Swirl Cooled Cross Fire Tubes FR1J

The advanced-tech cross fire tube design has swirl cooling holes, see Figure 30. Hardfacing at the liner collar may be ordered independently as offering FR1N.

The swirl cooling is performed by extra rows of cooling holes that are drilled at an angle. Air enters the angled holes to cool the inner surface of the cross fire tubes.

Hardfacing is created by a flame-sprayed chrome carbide wear coating that is applied to the two cylindrical surfaces at the interface with the combustion liners. The hard coating reduces fretting wear. The combustion liners have a corresponding hard coating on the cross fire tube collars. (Never mix hard coated and non-hard coated tubes/liners because wear will be increased.)

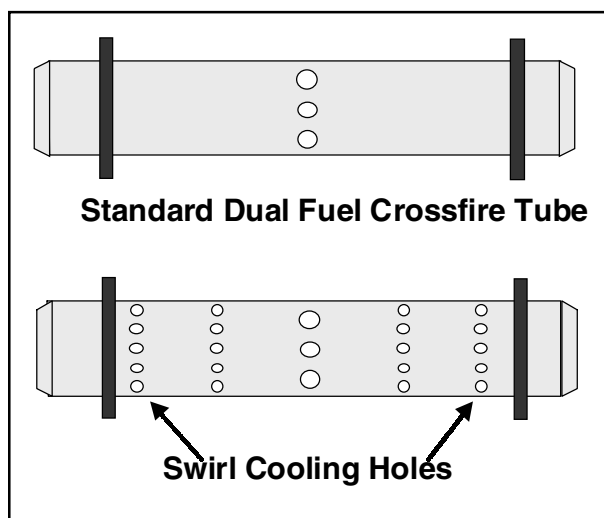

Figure 30. Advanced-Tech MS5001 Cross Fire Tubes

Combustion Liners FR1P

The advanced-tech combustion liners have thermal barrier coating (TBC) and have splash plate cooling around the cross fire tube collar. See Figure 31. In addition, hardfacing is available on the collar as option FR1N. The liner material is Hastalloy-X, which is the typical liner material for most turbine product lines.

The TBC consists of two materials applied to the hot side of the component; a bond coat applied to the surface of the part and an insulating ceramic layer applied over the bond coat, as shown in Figure 32. This 0.015 inch thick coating provides an insulating layer that reduces the underlying base material temperature by about 100 F (56 C) and mitigates the effects of hot streaking and uneven gas temperature distributions.

The liners use impingement splash plate cooling around the cross fire tube collars. Impingement cooling on the splash plate increases the cooling effectiveness at the collar location. This configuration reduces stress concentrations and cracking at the louvers experienced in the earlier design.

The new liners shift the center of the flame closer to the nozzle because of the change in the dilution air flow. This requires that the flame detector be tilted, rather than perpendicular to the turbine centerline. Present flame detectors will be repositioned as necessary during the uprate.

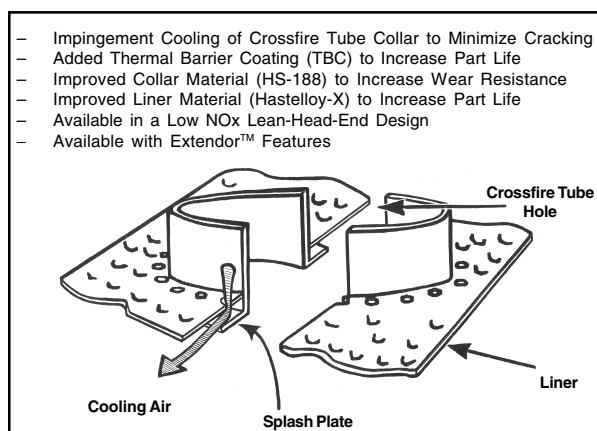

Figure 31. Advanced-Tech MS5001 Liner

The Low NO_x Lean Head End (LHE) Liner FR1B

The Low NO_x Lean Head End Liner is an alternate form for the standard advanced technology liner. The LHE liner provides more air flow in the combustion area of the liner by directing more primary air to the fuel nozzle. The increased air flow at the flame causes a reduction in NO_x formation by having leaner combustion. The air pattern change is evident on the cowl surface, as shown in Figure 33. The net NO_x reduction of applying a low NO_x LHE liner to a new-tech uprate is illustrated in Figure 34.

Field experience with gas-only fuel shows that the LHE liners more than compensate for the increase in NO_x that would occur due to the increase in firing temperature of a new-tech uprate by providing a 30% reduction in NO_x over standard liners. Also, the amount of water or steam injection required

to reach NO_x limits will be reduced if LHE Low NO_x liners are installed. Figures 35a and 36 show NO_x emission test data on the MS5002 simple and regen cycle LHE liners, which are fundamentally the same design as the MS5001 gas fuel-only LHE liners.

The Low NO_x LHE liner is also available for dual gas/distillate fuel turbines, and its NO_x reduction is about 15%. The dual fuel LHE liner is intended for turbines that burn gas fuel primarily. Atomizing air is required with dual fuel turbines. The LHE liner is not recommended for use in oil-fuel turbines without water or steam injection unless oil operation is for short duration only.

The same degree of flame detector tilting is required for the Low NO_x LHE liner as for the standard advanced technology liner. However, with the gas fuel-only version of LHE liners the flame is moved further away and so will appear more faint to the detectors. Therefore, for application of these liners on MS5001 L/LA/M and R models (not N or P), it is necessary to add two flame detectors (for a total of 4). Test data shows that during acceleration to full speed no load, the flame has a tendency to move out of the viewing area of the detector (even when the detector is properly tilted) resulting in a false “loss of flame” alarm. The control logic will also be modified to 3 of 4 voting during rotor acceleration to minimize the false flame-out readings and so avoid a nuisance shutdown. The 3 of 4 voting would be done with relays for Mark I and Mark II control systems.

CO emissions increase with a Low NO_x LHE liner running at partial power firing temperature, compared to a standard liner. The CO emissions at partial power are higher for the gas-only version than the dual-fuel version. CO emission test data of the gas-only version is provided in Figures 35b and 36.

Transition Pieces FR1Q

The advanced technology transition pieces have the following improvements, as shown in Figure 37:

- Hastalloy-X material is substituted for the original 309SS because it provides excellent tolerance to high temperatures and has good crack resistance.
- Wear and crack resistance is improved by a floating inner seal design with new side seals and increased corner radii on the aft frame.
- The new cylinder mount arrangement of the aft bracket reduces cracking in the body-to-mount region and increases the torsional stiffness of the installed transition piece.

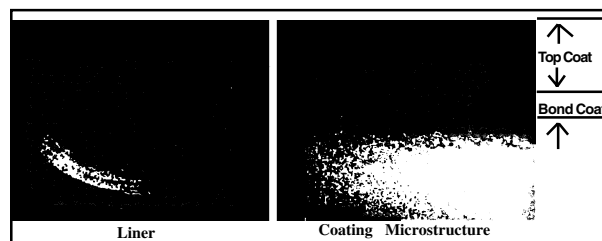

Figure 32. Thermal Barrier Coating

Extendor™ FR1V

Extendor™ is the set of hard coatings and claddings used to reduce wear in the combustion system, with the intent of extending the inspection interval. With the Extendor™ set package (FR1V), GE will recommend an extension of the combustion inspection intervals.

Extendor™ can be applied to combustion components by modifying hardware at an authorized GE service center or by having Extendor™ features built into (or “pre-applied” to) new combustion components during the manufacturing process.

The MS5001 Extendor™ combustion system was developed to reduce the effects of wear at the following interfaces:

- Liner stop lugs.
- Fuel nozzle tip to combustion liner fuel nozzle collar.
- Cross fire tube to combustion liner tube collar.
- Combustion liner hula seal to transition piece forward sleeve.
- Transition piece aft picture frame, inner floating seal and rat ears.
- Combustion liner TBC.

When considering Extendor,™ operators should determine the extent of wear that presently occurs on their turbine, which will be unique for a given turbine. This data is important in determining how Extendor™ will impact the combustion inspection interval.

New-Tech Upgrades for MS5001A-K Turbines FT3L

The MS5001R and MS5001R N/T uprate packages have been installed on several MS5001A-K turbines. A few of these turbines have been generator drive. The performance improvement of a full new-tech uprate on MS5001A-K turbines is given in Figure 38.

The new-tech uprate provides a large increase in power for these turbines. In addition, the new-tech uprate provides an increase in turbine availability, by converting to stocked parts that have longer in-service lives.

The MS5001A-K turbines have a fabricated turbine casing, and have different wheel and dovetail designs compared to the later MS5001L-R turbines. In addition, the tie-bar fixed seal transition piece to stage 1 nozzle interface is completely different than the MS5001L-R, as is the stage 1 nozzle retention. To install the new-tech uprate, the turbine casing has to be replaced, as well as the stage 1 and 2 wheels, and the distance piece as described below. The combustion covers, if clamped or with old-style covers, will have to be replaced. The turbine hood (exhaust frame) will also require replacement due to interfaces and material compatibility with the higher temperature. The load gear, if there were one, would likely require replacement during the uprate. The

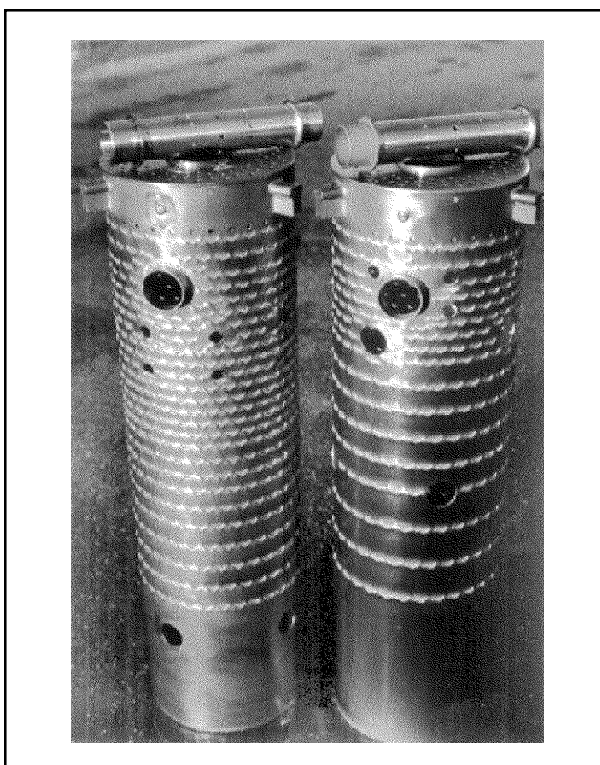

Figure 33. MS5001 Low NO_x Liner (Right Side)

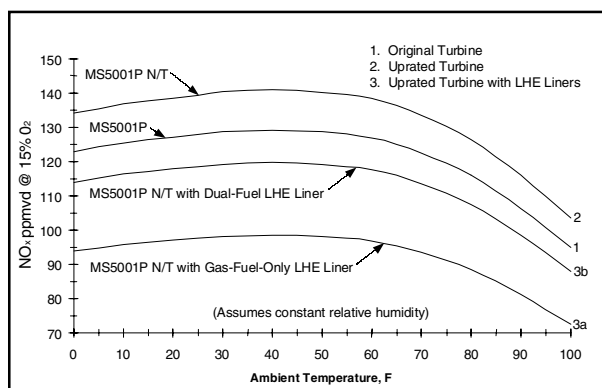

Figure 34. MS5001P Low NO_x LHE Liner Application to Uprate

hardware changes required for the MS5001A-K turbines are summarized in Figure 39.

These modifications are fairly extensive, and given the variety of designs in the MS5001A-K family, many of the modifications are designed to meet the specifics of the turbine after the order is placed.

The advanced-tech combustion system hardware can be applied with minor modifications: liners and cross fire tubes after replacement combustion casings and covers and fuel nozzles; transition pieces after modifications to the S1N hardware for mounting.

Commonly GE is requested to propose an MS5001A-K modification that permits modern production turbine-section parts be installed, such as a S1 nozzle or S1 bucket set. These modifications are extensive, and often require machining to the casing, the rotor flanges, and interfacing hardware. Performance is also impacted adversely due to tip clearances and nozzle area differences. The inactive thrust bearing could be adversely impacted if only select parts are substituted into an MS5001A-K turbine. Given these factors, it is often preferred to have a full uprate to the MS5001R or a MS5001R N/T configuration rather than individual part substitutions.

Improved Stage 1 Shroud Block Sealing (S1S) FS2Y

The advanced seal version of the S1 shroud blocks has:

- Spline seals that replace the traditional pumpkin teeth and bar.
- “W”(or “E”)-spring seal that makes the sealing robust if the block moves relative to the S nozzle, or if the S1 nozzle is warped due to refurbishment.

Figure 40 shows the difference between the pumpkin teeth design and the advanced seal design.

The S1S blocks can be purchased with an abraidable coating (FS6A), rather than the five mils of hard coating typically applied. The abraidable coating serves two purposes:

- Reduces S1 bucket tip clearance so much so that the bucket may rub to form the tightest possible clearance.
- Compensates for ovality in the turbine shell, replacing the round-out procedure. To minimize abrasive wear on bucket tips, the abraidable coating thickness is typically tailored, with a different coating thickness on each shroud block, ranging from 20 to 80 mils. To minimize outage time, the material and measurement process has to be coordinated by the GE project engineer.

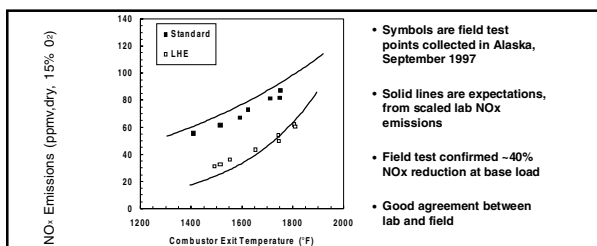

Figure 35a. MS5002 Gas Fuel-Only LHE Liner NO_x Test Data

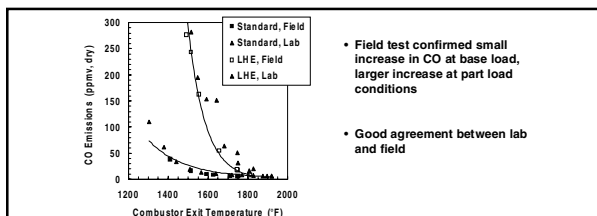

Figure 35b. MS5002 Gas Fuel-Only LHE Liner CO Test Data

Stage 2 Shroud Blocks with Honeycomb Seals (S2S) FS2T

The advanced seal version of the S2 shroud block has honeycomb brazed onto it to reduce the bucket tip clearance. See Figure 41. The honeycomb material is abradable, but requires the S2 buckets to have “cutter teeth” on their tip shroud rails. See Figure 42.

The cutter teeth come as cast-on features with the latest long-shank bucket design. It is cost effective to have welded-on cutter teeth added to S2 buckets only if the buckets still have considerable life remaining. Short-shank tip-shroud S2 buckets have the cutter teeth added only by welding. A GE service shop can quote the welded-on cutter teeth, and will quote the modification for every other bucket (half the set).

Stage 2 Nozzle Diaphragm Brush Seal FS2Z

The advanced seal version of the S2N diaphragm includes a brush seal for the interstage packing. The brush seal reduces leakage across the interstage seal. The nozzle diaphragm is redesigned to have aft-side air injection holes, as well as the forward-side holes. By resizing the holes, to take advantage of the reduced seal leakage, the two interstage wheelspaces are cooled with a minimal amount of cooling air. The air that is saved is used by the turbine cycle to create power. Hardfacing of the turbine rotor is not required. The location of the brush seal is given on Figure 16.

The S2N diaphragm and brush seal is presently only available on the new-tech S2N design. An old-tech (180 degree segment) S2N version of the brush seal is in development.

COMPRESSOR MODIFICATIONS

R to P Compressor Uprate FT3F

An MS5001R or R N/T turbine can be substantially uprated by converting the 16-stage compressor (R type) to a 17-stage compressor (P type). With the larger compressor, the exhaust flow increases by 26%, the exhaust temperature drops by 63 F, the compressor pressure ratio increases by 29%, the output power increases by 32%, and the heat rate decreases by 7.5%.

A comparison of the R and P compressors is illustrated in Figure 43. The performance impact is illustrated in Figure 44.

The P-compressor retrofit involves changing out the bellmouth, the forward and aft compressor cases, and the stage 1, 2, 3 and 10 wheels, blades and vanes, and adding a zero stage and variable IGVs. The standard retrofit package includes the full set of compressor blades and vanes to remove old airfoils that might not be able to withstand the increase in loading on them, resulting from the increased airflow and stage pressure ratios.

Due to the substantially higher airflow, the uprate from the R- to the P-compressor involves rework to the inlet plenum. Similarly, the inlet house and duct may need to be enlarged. Any heat recovery exhaust equipment needs to be made compatible with the higher airflow and lower temperature.

Seventeen P-compressor uprates had been performed as of 2000.

IGV Upgrades FT3I, FT3C

Reduced camber IGVs were designed in 1987 as part of the 7F development project. Reduced camber IGVs were applied across the GE product lines at that time, and are available for both the P and the R style MS5001 compressors.

The P-compressor reduced camber IGVs can be set at 85 degrees, for optimal heat rate, or at 86 degrees, for optimal output power. The P-style reduced camber IGVs are made from GTD-450, a superior strength and corrosion resistant stainless steel.

The performance impact of the 86 degree MS5001N, P reduced camber IGVs and the 82 degree MS5001A-M, R reduced camber IGVs is given in Figure 45. The design of the reduced camber IGVs is presented in Figure 46.

The P-compressor IGV kit includes a set of tight clearance, wear resistant IGV bushings, and can also include a replacement rack and ring assembly. The rack and ring should be replaced if gear wear causes a backlash that is out of limits and cannot be cor-

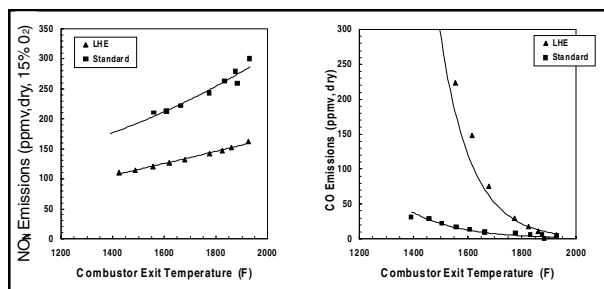

Figure 36. MS5002 Gas Fuel-Only LHE Liner Test Data, Regen Cycle

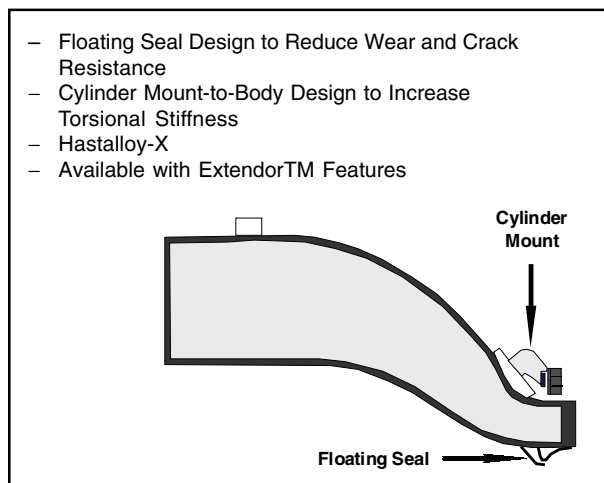

Figure 37. Advanced-Tech MS5001 Transition Piece

Models	Firing Temp. °F/°C	Estimated % Output Increase	Exhaust Temp (°F/°C) Increase
A	1755/927	68%	+ 141/78
C	1755/927	68%	+ 146/81
D	1755/927	68%	+ 146/81
E	1755/927	57%	+ 151/84
G	1755/927	50%	+ 151/84
H, J	1755/927	44%	+ 161/89
K	1755/927	44%	+ 161/89

Figure 38. New-Tech Uprate, MS5001A-K Potential

rected for by adjusting the rack or pinions. In cold environments an inlet scroll may be required to smooth out the airflow, especially with the 86 degree setting.

The fixed R-compressor reduced camber IGVs, applicable to MS5001A-M and R turbines, come at 82 degrees, and are 316SS material, which has superior corrosion resistance. Also, 316SS is more compatible with the blade/ring blazing processes, compared to GTD-450.

GECC-1 Coated Compressor Blades FS2A, FS1F

GECC-1 is an inorganic aluminum coating that provides excellent corrosion protection for compressor hardware. It is applicable to the 403CB stainless steel blades and other casing/rotor hardware. The GTD-

450 material should not be coated.

The GECC-1 coating can be applied to airfoil components such as blades and vanes, or it can be applied to installed airfoils. Blade/wheel assemblies can be coated, typically in a shop. Vanes, installed on the half shell, often can be coated at the installation site.

The standard set of MS5001 GECC-1 coated compressor blades and vanes has GECC-1 coating applied up to the seventh stage. The first seven stages are where liquid water, with its possible acid and salt content, remains unevaporized by the heat of the compressed air. For turbines that have daily cycling or extended outage time, it is useful to have all the compressor stages coated with GECC-1, because moisture can reach all the blades.

The compressor moisture is typically caused by condensation of water vapor due to the drop in pressure that naturally occurs to the accelerated airstream of the compressor inlet. The water vapor fog mixes with NO_x , SO_2 , and HCl in the air to create an acid solution that is very corrosive. NaCl in the air will also create a corrosive solution. The moisture collects on the blade surfaces, particularly the IGVs and first few stages. The rising of air temperature through the compressor vaporizes any moisture by stage 7 or stage 8. For this reason, the first few stages are GTD-450, which is the most corrosion resistant compressor material, and the SS403CB airfoils up to stage 6 or 7 or 8 are coated with GECC-1.

The compressor efficiency is degraded when corrosion occurs on the airfoils. Also, the corrosion sites become more accommodating to a build-up of debris and so water wash becomes difficult. If corrosion pitting progresses unchecked, then the stress concentrations associated with the pits become crack initiation locations with the potential for compressor failure.

Turbines that are in humid coastal regions have a highly corrosive environment for the IGVs and the first several stages, and need frequent inspections. C-450 and GECC-1 materials would be very beneficial.

GECC-1 will be damaged if pecan shells or other abrasive solids are used for compressor blade cleaning. Therefore, if GECC-1 is applied, it is best to have a good inlet filtration system, such as a two-stage prefilter/filter or cleanable filter system. An off-line water wash system is recommended, and an on-line water wash system is an additional option.

A typical problem for turbines is that rust that forms between the compressor wheels can collect to create an out-of-balance. GECC-1 can be applied to the stage 1 or 2 or 3 through stage 7 or 16 wheels (with SS403CB blades installed) to prevent the rust from forming between the wheels. The GE service

Sourcebook Code		5001A-K	5001L/LA/M	5001N/P/R
FR1L	- Floating Seal Transition Pieces	X	X	X
FR1G	- TBC Coated Combustion Liners with Splash Plate Crossfire Tube Collars	X	X	X
FT3O	- 2 Vane Stage 1 Nozzle	X	X	X
FT3R	- GTD111 Stage 1 Bucket	X	X	X
FT3T	- 4 Vane Cast Segment Stage 2 Nozzle	X	X	X
FT3E	- Shrouded Tip Stage 2 Bucket and New Stage 2 Turbine Wheel	X	X	-
	- Turbine Shell	X	-	-
	- Distance Piece	X	-	-
	- Stage 1 Turbine Wheel	X	-	-
	- Outer Combustion Casings	X	-	-
	- Exhaust Frame	X	-	-
FS1U	- Stainless Steel Exhaust Diffuser (High Ambient Temperature Only)	X	X	-

Figure 39. New-Tech MS5001 Hardware Changes

shop can clean rusted wheels. Even with GECC-1 on the wheels, the turbine should be run after an off-line water wash, per the standard procedure.

The patented GECC-1 coating system provides an aerodynamically smooth, high temperature (to 1000 F) corrosion resistant duplex coating, 2 to 4 mils thick. The GECC-1 coating system consists of a dense, aluminum-filled inorganic basecoat that provides outstanding sacrificial galvanic corrosion protection. A ceramic pigmented inorganic topcoat effectively seals the basecoat, enhances GECC-1's smoothness, and extends coating life through significantly increased erosion and corrosion resistance. GECC-1 provides the following benefits:

- Extended component life
- Reduced maintenance costs
- Increased water wash cleaning effectiveness
- Reduced fouling from solids in the air
- Minimized corrosion induced rotor imbalance
- Improved surface finish retention (for less rapid compressor efficiency degradation)
- Corrosion protection in industrial and marine environments

High Pressure Packing (HPP) Seal Relocation to Compressor Side

The MS5001A-K and some MS5001L turbines have the high-pressure packing seal located on the turbine side of the rotor's distance piece. The later MS5001L-P turbines have the seal on the compressor side of the transition piece. The HPP seal needs to be on the compressor side when the firing temperature is raised above the 1620 F level. For the MS5001A-K (and some L) turbines GE will relocate the HPP seal to the compressor side when the turbine is uprated.

Moving the HPP seal involves a teardown of the rotor and should be performed at a GE service shop. It is convenient to do when the stage 1 and stage 2 wheels are replaced during an uprate to the MS5001R or MS5001R N/T configuration.

HPP Brush Seal FS2V

The high pressure packing (HPP) is the seal that limits the quantity of first forward wheelspace cooling air, which bypasses the first stage nozzle. Cooling air beyond the minimum needed results in a performance loss.

A brush seal in the high pressure packing reduces this cooling air, and makes the seal more robust against rubs due to thermal transients that would permanently open up the traditional HPP labyrinth seal.

The brush bristles are angled in the direction of

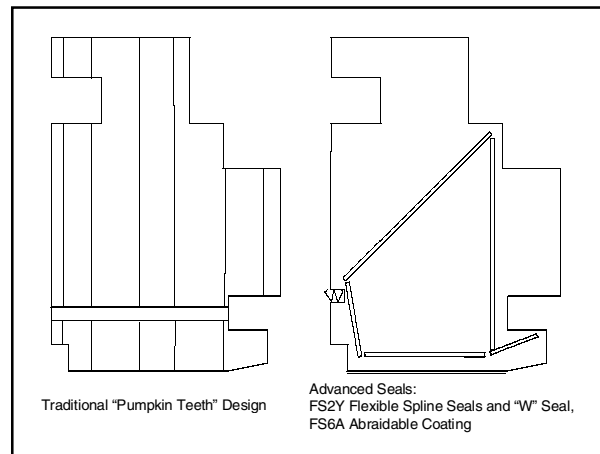

Figure 40. S1 Shroud Block Sealing Designs

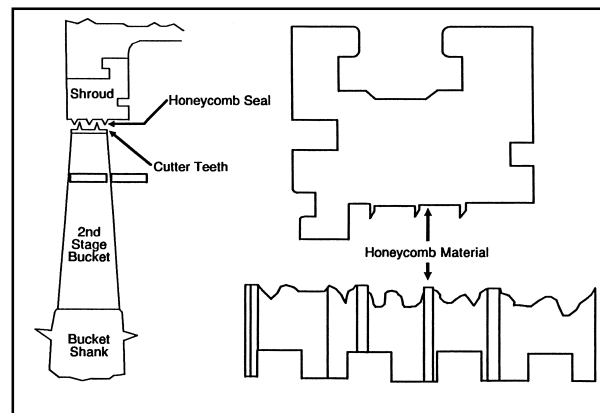

Figure 41. S2 Shroud Block Honeycomb Seal

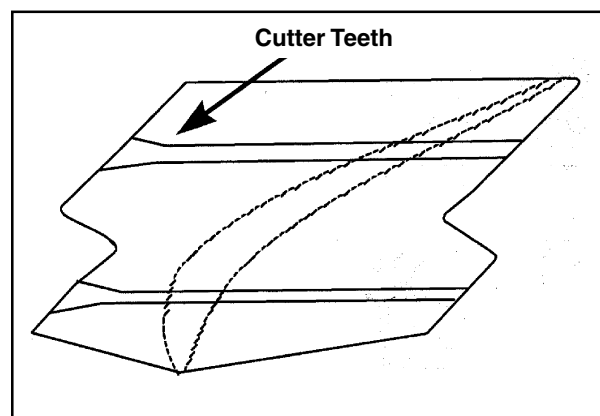

Figure 42. S2 Bucket Cutter Teeth

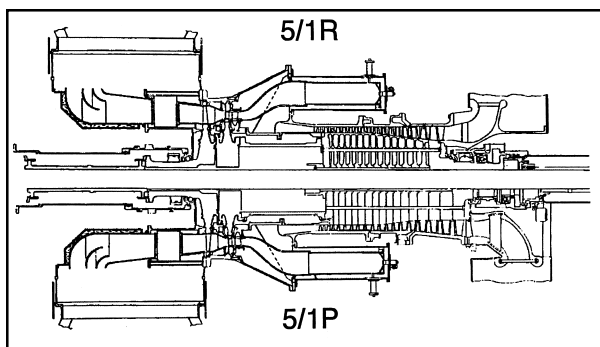

Figure 43. Comparison of MS5001R and MS5001P Compressors

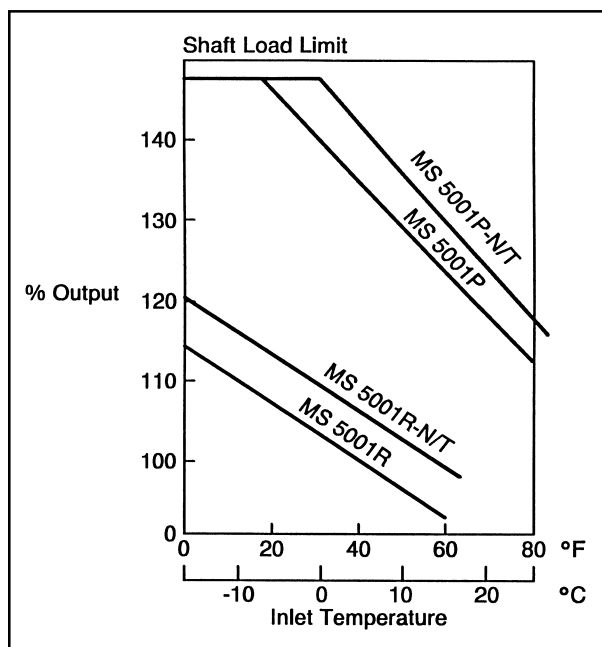

Figure 44. Performance Comparison of MS5001 Uprate with Uprated Compressor

rotation, so that they elastically bend during a thermal transient excursion, and then return to normal afterwards. See Figure 47 for an illustration of the brush.

An increase in labyrinth seal clearance due to a rub causes a permanent performance loss. The predicted performance benefit of a brush seal as quoted by GE is relative to a relatively new turbine, and so is in addition to performance lost due to large labyrinth seal rubs.

The first week or so after the HPP brush seal installation is called the break-in period, when the initial 10-mil brush-to-shaft interference wears away. During this time on MS5001 turbines, the wheelspace thermocouple readings may be slightly high. An HPP seal bypass can be installed so that the turbine can run at full power during the break-in period. When wheelspace temperature has dropped by 40 F or so, the bypass would be plugged.

Hardfacing of the turbine rotor at the brush seal interface is not required.

CONTROLS MODIFICATIONS

For a given turbine, the two ways of increasing output power are (1) increasing the mass flow such as with advanced seals or power augmentation or turbine speed, and (2) increasing the firing temperature. Firing temperature would be changed by increasing the fuel flow by modifying the controls, specifically by modifying the slope or intercept or isotherm of the control curve.

Tailored Control Curve FT7I

The MS5001 temperature control curve is a linear relationship between exhaust temperature and compressor pressure or pressure ratio, such that, at a given compressor pressure ratio, the fuel flow will increase until the specified exhaust temperature is reached. The relationship between compressor pressure ratio and exhaust temperature is assigned so that the slope gives the correct constant firing temperature. The slope is angled such that hot inlet temperature corresponds to a high exhaust temperature.

The isotherm is the maximum permitted exhaust temperature. The isotherm has a maximum limit based on the capability of the exhaust hood (or exhaust frame), which, for MS5001 turbines, typically is 1000 F for SS409 and Cor-ten-A and 1050 F for SS304L. Cor-ten-A is typical on MS5001L-M and some R turbines, because of the low firing temperature, and on MS5001N-P because the high airflow causes the exhaust temperature to be low. The MS5001R N/T has the highest exhaust temperature of MS5001 turbines, and on hot days (when power is probably most wanted) the exhaust temperature could easily reach the 1000 F isotherm before reaching full firing temperature. It is also possible that joints in the exhaust ducting to a boiler require a lower isotherm, so the customer should be aware of this additional restriction when specifying conditions for an uprate.

Variable IGV-Design Turbines					
Reduced Camber High Flow GTD-450 IGV					
Sourcebook Codes			Incremental Changes		Temperature Change
			Output	Heat Rate	T_{Ex} (F/C)
FT3C	MS5001N/P	Pre-1978	3.9%	-0.2%	-11/-6
FT3C	MS5001P	1978 Thru 1987	1.9%	-0.5%	-4/-2
FT2B	MS5002B	Pre-1978	3.8%	-0.1%	-10/-6
FT2B	MS5002B	1978 Thru 1987	1.8%	-0.3%	-4/-2
FT4C	MS6001B	Pre-1988	1.9%	-0.2%	-2/-1
FT5B	MS7001B		4.8%	-0.7%	-12/-7
FT5B	MS7001C		4.5%	+0.1%	-11/-6
FT5B	MS7001E	Pre-1988	1.9%	-0.1%	-3/-2
FT5B	MS7001EA	Pre-1988	1.4%	-0.3%	-2/-1
FT6B	MS9001B		4.8%	-0.7%	-12/-7
FT6B	MS9001E	Pre-1988	1.9%	-0.2%	-2/-1
Fixed IGV-Design Turbines (316-SS IGV)					
FT1F	MS3002 A Thru J	Pre-1978	2.2%	-0.5%	-6/-3
FT3I	MS5001 A Thru M and R		1.0%	-0.3%	-2/-1
FT2M	MS5002A		1.1%	-0.4%	-2/-1

Figure 45. IGV Uprate Performance Comparison

The standard control curve is based on the assumption that the ambient conditions range from 59 F 60% humidity to 90 F 20% humidity (same absolute humidity) such that the turbine will run about half the time in that range when the turbine will be slightly overfired and half the time out of that range when the turbine will be slightly underfired, so that the firing temperature evens out. By changing the lower design temperature to 45 F, for, perhaps, a continuously chilled inlet turbine, or the upper design temperature humidity to 60% for a tropical humid environment, the turbine will have a higher firing temperature at 45 F or at 90 F. Site specific control curve tailoring (FT7I) such as these results in more power at a desired operating condition and a more accurate firing temperature. Control curves can also be tailored to account for changed inlet and exhaust pressure drop, or degraded compressor or turbine casings. Of course it should be understood that if the end result of tailoring the control curve were that the turbine runs at a higher average firing temperature, then there would be more refurbishment needed at the next inspection.

Exhaust Diffuser FS1U

GE can supply a replacement exhaust diffuser, consisting of either a full turbine exhaust frame (with turning vanes) or else simply the reskinning material. Exhaust diffuser replacement would be required for an increase in the exhaust temperature control

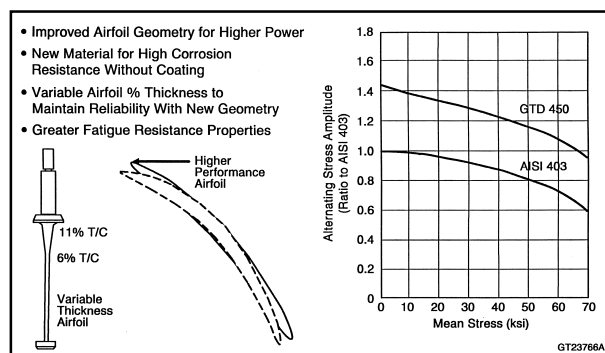

Figure 46. IGV Design Improvements

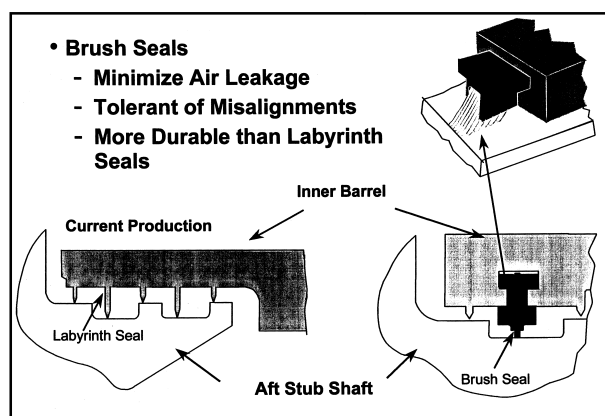

Figure 47. HPP Brush Seal

curve isotherm, from 1000 F to the maximum of 1050 F which requires 304L stainless steel.

Exhaust diffuser replacement due to degradation of the existing equipment is available, but the degradation typically extends down to the structure of the frame, requiring the whole frame to be replaced. Applicable materials for reskinning are 409 (muffler steel), Cor-ten A, and the 304L which has the higher temperature capability but also a higher coefficient of expansion which needs to be compensated for in the frame structure design.

Reskinning the exhaust frame is difficult without proper fixtures and expertise. One method of reducing cost on a fleet of turbines is to purchase one exhaust frame, and cycle the removed frames through a refurbishment shop.

Tilted Control Curve FT7I

The tilted control curve provides more power on hot days (when power is probably most wanted). The exhaust temperature is permitted to increase on the hottest days, to 10 F above where it would typically be. This increases the firing temperature 17 F for about 1.7 % additional output power. However, the exhaust temperature cannot go above its isotherm, so if the exhaust temperature is already at the control curve isotherm, then the tilted control curve will not offer any benefit.

The average firing temperature has to remain approximately the same as it was prior to implementing the tilted control curve. To accommodate this requirement, the firing temperature is suppressed 25 F for the lowest ambient design temperature, for about a 2.5% loss of output power. During nights and winter days, the turbine will provide somewhat less power. A sample tilted control curve is given in Figure 48.

For the MS5001, tilting can only be done on turbines with new-tech hardware: MS5001M N/T, R N/T, P N/T, RA, or PA turbines. Tilting cannot be done on a peak power control curve, because peak power is expected to be primarily used on hot days.

Each application of a tilted control curve has to be assessed by GE engineering to ensure the effective average firing temperature does not increase, so that parts life is not reduced. This requires more hours underfiring the turbine to balance out overfiring. A special counter or other control may be required.

Biased Exhaust Thermocouples

Biasing of exhaust thermocouples is only applicable to a few types of thermocouple designs. It is not applicable to the thermocouple type described in TIL-1270.

Prior to the design of TIL-1270, the exhaust thermocouples had a material junction that degraded when it is first put in service. This degradation was not properly accounted for in many control systems. Those turbines with the pre-TIL-1270 or with control systems not accounting for the degradation have been operating with an artificially reduced firing temperature because of the degradation.

Now that GE understands this junction degradation, it is possible to adjust the control tuning constant for the exhaust thermocouples so that the firing temperature is increased appropriately.

For typical Mark I control systems and earlier control systems, the junction is a Type J. The bias effect is to increase exhaust temperature +6 F, which results in about a +9.5 F increase in firing temperature, for about 0.95% increase in output power.

For typical Mark II and later control systems, the junction is a Type K. The bias effect is to increase exhaust temperature +11 F, which results in about a +17.5 F increase in firing temperature, for about 1.7% increase in output power.

It is a requirement that the exhaust thermocouples be purchased from GE. It is also recommended that this biasing only be done on turbines with new-tech hot gas path hardware. A GE engineer can review the control spec and other documents to determine if the bias has already been applied.

The biasing of exhaust thermocouples will directly increase the firing temperature. All other variables being equal, the increased exhaust temperature will cause an increase in the refurbishment required of the hot gas path hardware when inspected next.

Peak Firing Temperature

Turbine controls have the capability of including a peak firing temperature. The peak firing temperature can be set substantially higher than the base

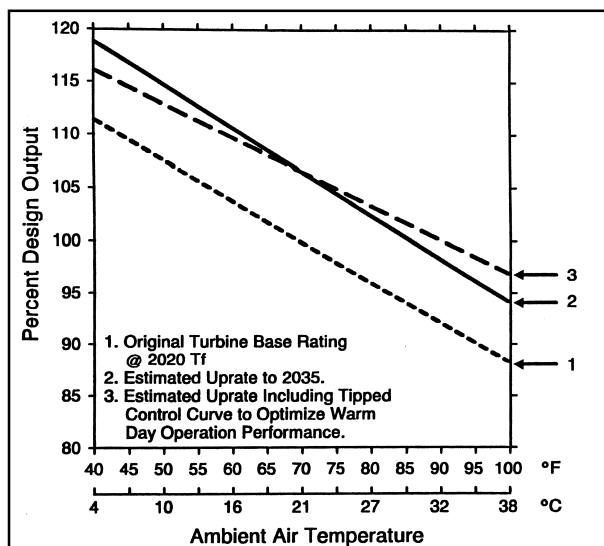

Figure 48. Example of Tilted Control Curve (MS7001E)

load firing temperature. During hours with peak firing temperature, the maintenance factor is increased.

For an MS5001, the relationship of maintenance factor (MF) vs firing temperature increase is more severe than on the “E” class turbines (as described in GER 3620G) due to the uncooled stage 1 bucket.

Mechanical drive turbines do not have a peak load control option.

Auto Peak Control

A temporary peak control curve can be applied to mechanical drive turbines, so that the turbines do not need to operate steady-state at reduced output. Mechanical drive turbines typically operate at a maximum load that is reduced from their maximum capability (a typical reduction is about 10F to 20F less firing temperature) so that the turbine does not speed-droop and overtemperature-trip during an event where the compressed gas load increases transiently.

The controls can be modified to permit the turbine to over-fire for more output during the event. This control modification would permit the turbine to run at 100% base load continuously.

The over-firing of the turbine is a peak-load event. The peak-load operation is accompanied by an alarm. The operator is required to immediately correct the load problem so that the turbine returns to base load within a set time (an hour or so) to prevent a turbine automatic shutdown.

As with the other control modifications that increase a turbine’s average firing temperature, all other variables being equal, a higher firing temperature will require a more extensive refurbishment of the parts at the next inspection.

Speed Change to 5355 rpm FT3X

The speed of an MS5001 P, R, P N/T, or R N/T turbine can be increased to 5355 rpm. The increased speed provides more power on hot days, but also less power on cold days due to excessive mass flow in the turbine that hurts efficiency. Load-Compressors that can be uprated to take advantage of the higher speed will benefit substantially.

Generator drive turbines that require a replacement gearbox for the higher torque rating required of a new-tech uprate may find the higher speed version of the replacement gearbox more desirable.

The higher rotational speed increases the stress, and therefore crack growth, on the S1 wheel, enough so that the number of starts is limited to ten per year. Also, the higher speed increases the stress on the S1 bucket, increasing the creep rate, enough so that, with the heavier solid GTD-111 bucket, the firing temperature has to be suppressed 25 F. These restrictions are given in Figure 28.

The 5355 rpm operating point is 105% of the 100% speed 5100 rpm. The 5% difference was originally intended for overspeed operation. Design analysis shows that there is a minor rotor bending critical speed at about 5400 rpm. Therefore, operation at 5355 rpm does not conform to the API requirement for a 5% speed margin from all critical speeds. However, no vibrational problems have resulted on the units that have had their speed increased.

Figure 49 provides a sample performance plot from an MS5001P proposal for 5355 rpm that included a new-technology uprate. The firing temperature had to be decreased because the stage 1 buckets have a solid construction. Even so, there is a 3% power output improvement during hot days due to the speed change. On cold days, the loss in performance is not important because the controls restricted output power based on the torque limit of the stage 2 wheel's aft stub shaft.

Speedtronic Mark V and Mark VI Simplex FK1V

The Speedtronic control systems, Mark I and Mark II, can be upgraded to a Mark V or Mark VI relatively easily. The upgrade is often necessary due to either a lack of spare parts availability or as part of a larger overhaul where the features are being expanded. The Mark I and Mark II are difficult to modify due to the availability of parts and trained personnel.

As an alternative to a full control system upgrade, the Fuel Regulator, Mechanical Regulator, or Mark I or Mark II control systems can have features expanded by the use of GE Fanuc PLC-based packages. These packages have been pre-engineered to be included with fuel conversions, modulating IGVs, water or steam injection, exhaust temperature protection, and other control functions. Multiple control functions can be offered with one PLC system.

Replacement of Fuel Regulator Controls FK1V

The mechanical and the electrical fuel regulator systems can be upgraded to the Mark V or Mark VI. The conversion involves a modernization where the scope typically includes a replacement of the speed detection device to mag pick-ups, a replacement of the Fisher tier with electronic-based equipment for the PCD (or speed) ratio valve control, and can include a replacement of the Hydraulic Position Servo with an I to H (Current to Hydraulic) converter to control the gas or liquid fuel control valve.

The low-pressure hydraulic supply for the control valve would be a reuse of the CCO hydraulic pump.

An electric actuator can be applied to the speed ratio valve and/or the control valve / stop valve. Alternatively, for sites that have little variation in fuel gas supply pressure, a single electric valve can replace both the speed ratio valve and gas control valve. An electric stop valve system is designed for the combined valve system.

Also, it is convenient at this time to replace the pneumatic system with a high pressure (HP) hydraulic system, which involves a modification to replace the following items as applicable: speed ratio valve actuator, clash pinion on the ratchet, cylinder on the jaw clutch, and diesel accelerators. The HP conversion requires the addition of a hydraulic system and replacement of all fuel control equipment for HP actuation.

90L Relay FL3G

The load regulator 90L Sigma magnetic amplifier relay in the generator switch-gear panel on turbines built up until the 1980s cannot be replaced in-kind since 1990. GE has developed a controller device that replaces its function and fits on the same panel.

INSTRUMENTATION

Extended Exhaust Thermocouples FK5B

The extended exhaust thermocouples are more accessible for maintenance.

The extended exhaust thermocouple design is comprised of a hermetically sealed unit with mineral insulation in a high-temperature sheath providing capability to 1000F over its full extended length up to, but not including, the termination end. The thermocouple is nine feet in length, permitting termination at a junction box located outside the lagging where the temperature ranges are lower (200-250F) compared to the rear wall of the exhaust plenum. To provide a high-response junction, the reduced diameter of the thermocouple tip has been maintained.

This design provides a more sensitive thermocouple that allows the control system to reduce over-firing of the unit during transients for better hot gas path parts life.

As an alternative to this offering, GE is developing a new thermocouple design that will soon be available for the MS5001.

Removable Wheelspace Thermocouples FK5C

The removable wheelspace thermocouple fits into a closed well consisting of a single run of tubing. This is superior to the first-style of removable thermocouples on MS5001s, which had an open well, and a torturous path for the thermocouple that utilized turning blocks, and often the thermocouple could not be removed.

The new-technology removable wheelspace thermocouples allow for replacement of the thermocouple without removal of the casings. The replaceable thermocouples are more rigid than the old-technology and are less subject to failure. The reliability is further improved due to the increased shielding and the relocation of the termination point out of the turbine compartment.

Removable wheelspace thermocouples are standard with the new-tech S2 nozzle. Otherwise, they are best installed as part of the S1 nozzle and S2 nozzle refurbishment at a GE service shop. Some on-site casing machining is required.

Reuter-Stokes Flame Detectors FK5J

In contrast to the Honeywell system, the GE Reuter-Stokes Flame Tracker utilizes a silicon carbide photodiode, which has high sensitivity to the longer UV wavelengths typical of hydrocarbon flame, and so can penetrate the fog of fuel and steam quite easily. This upgraded flame detector system also uses a convenient low voltage (12-30 vdc @ >50 mA) power supply and has an analog output with a very wide dynamic range and fast response time. Additionally, the flame sensor has been designed as a direct replacement of existing sensors and interfaces with the GE Mark I, II, IV, and V controllers. Quick disconnect connectors simplify routine maintenance and cleaning by reducing this operation to as little as five minutes per sensor.

The following are several features and benefits of the GE Reuter-Stokes flame sensor:

- Substantially more sensitive than all previous flame detectors. This provides reliable operation when using any fuel, with or without steam injection, eliminating signal “flicker”. Increased sensitivity permits monitoring of combustion product build up on the window, which allows for planned maintenance for window cleaning. Additionally, increased sensitivity also allows online water wash to take place if it otherwise had a false flame-out problem.
- Utilizes quick disconnect connectors. These will reduce required flame sensor cleaning and maintenance from hours to minutes.

- Low voltage operation eliminates special wiring and explosion-proof conduit in hazardous environments.
- Improved sensor cooling reduces condensation on windows.
- Designed to be mechanically and electrically interchangeable with the existing sensor, which simplifies the conversion to the new sensor.
- Fast response, combined with high sensitivity over a wide dynamic range provides the ability to track flame dynamics including fast response to flame-out.

IMPORTANT MS5001 MODIFICATIONS Wheel Inspections

GE recommends that all turbine rotors be sent to a GE service shop for a full inspection of all wheels. This inspection should be performed after 5000 cycles or 200,000 hours.

#2 Bearing Modification FS1D

When the turbine is next disassembled, the #2 bearing and lube oil piping on MS5001L-R turbines shipped before 1978 should be modified per TIL-413C. GE engineering has a list of affected turbines, which have serial numbers between 147856 and 245222. This mod shims up the bearing housing under the aft ears and replaces some of the rigid drain piping to avoid bearing babbit distress.

Inactive Thrust Bearing Upgrade FS1T

P-compressor turbines (MS5001N, MS5001P) should have an upgrade to the Inactive Thrust Bearing, especially those turbines that have extended time at full-speed-no-load or other reduced loads, such as is typical of a cyclic-load turbine. The past bearing failures were more common on turbines with worn seals. The field failures that prompted this bearing redesign have occurred on only a few R-compressor type turbines, but regardless, many MS5001A-M, R turbines have had this modification as well.

Refer to TIL-533C, and also reference TIL-1019-3a and TIL-1028-3a. Failure of the inactive thrust bearing occurred with blade/vane tip damage and heavy axial rubbing between the turbine wheels and stationary components. The replacement higher capacity, self equalizing, tilting-pad thrust bearing is able to support the thrust load more reliably.

The rotor stub shaft thrust collar must be machined at a GE service shop to allow room for the thicker self-leveling inactive thrust bearing. Type J

or K dual element thermocouples can be provided as an option, as can a readout monitor for turbines with early model control systems.

If the turbine rotor is in a GE service shop, it would be prudent to remove 0.300 inches from the aft side of the thrust collar as required for the upgraded bearing. If the inactive thrust bearing is not being upgraded at that time, then the 0.300 inches will be compensated for by placing a thicker shim behind the bearing.

SSS Clutch for Starting Means FC1M

Turbines having a clutch that has been re-started before a full stop will have damaged the jaw clutch. GE recommends replacing the whole jaw clutch, rather than just the sliding half, to ensure proper engagement and operation and have easy installation.

The SSS 64T starting clutch is recommended as a replacement to the jaw clutch. The SSS starting clutch is illustrated in Figure 50. A comprehensive review of its application in an MS5001 turbine is given in ASME paper 93-GT-181. The SSS clutch needs to be purchased through GE so that the shaft interfaces can be made compatible with the specific turbine.

The SSS 64T clutch has several advantages over the jaw clutch. The primary advantages of the SSS clutch are (a) an ability to re-start while the turbine is still rotating (500 rpm and less) which saves considerable time when a start is needed, (b) automatic engagement (no servo control system), and (c) robustness with very little maintenance.

Although the SSS clutch is more expensive than the jaw clutch, GE includes the SSS clutch as standard hardware on new-production MS5001 turbines.

A shaft-adapter, piping, wiring, and a minor modification to controls will be included with the SSS clutch. For a Mark I or Mark II system, there will have to be several modifications to remove the permissions incorporated with the jaw clutch system. The SSS clutch is a very convenient addition to a Mark V control conversion.

Torque Converter

The MS5001 replacement torque converter has a tapered circuit design for a broader torque/power/speed capability, and so is applicable to all MS5001 models. It has been standardized to a new envelope that does not fit as a replacement for the original torque converter on all but recent MS5001 turbines. The original torque converter model is no longer available. If the replacement torque converter is applied

with a replacement or the original jaw clutch, the starting engine or motor must be relocated about one or two more inches away from the accessory gearbox which requires additional rearranging in the accessory module, which is a large and undesirable task. If the MS5001 torque converter cannot be refurbished or an in-kind replacement found, then GE engineering can evaluate the specific torque converter / clutch design, and determine if the application of an SSS clutch can make the new MS5001 torque converter fit.

Accessory and Load Couplings FP1A, B, G, H

GE offers dry diaphragm type couplings for accessory and load couplings. The dry diaphragm type couplings handle higher degrees of misalignment than continuous lubricated couplings, they are non-wearing so they require no maintenance, and they are lighter and so create less vibration.

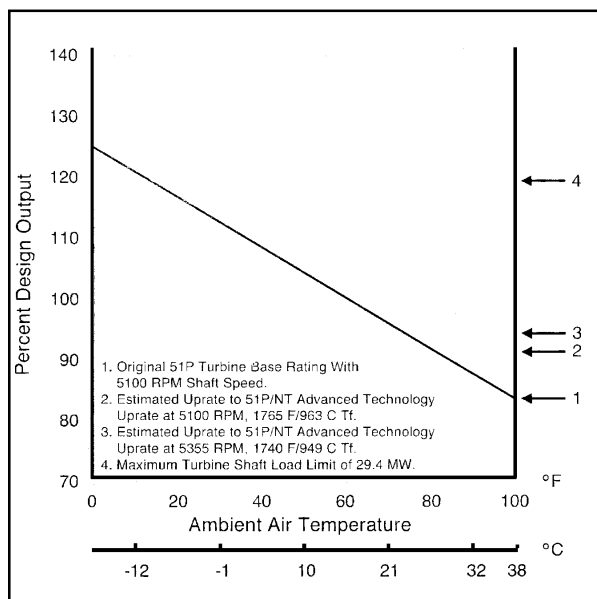

Figure 49. Performance Impact of 5355 rpm on MS5001P

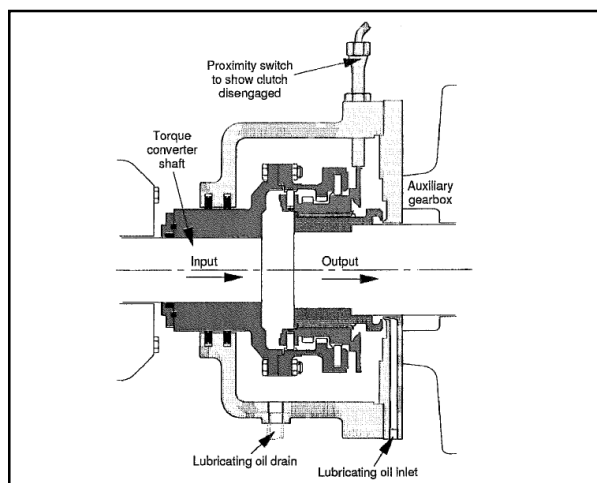

Figure 50. SSS Clutch

Turbine Frame	Gear Model Family	Original Speed rpm	Original Output Speed rpm	Uprated Model Family	Possible Turbine Speed, rpm	Maximum Rating MW hp	
51A-D	S-385	4860	3600 or 3000	<i>No S-385 Replacement Yet Developed.</i>			
51C-L	S-424	4860	3600 or 3000	S-4/524	5100 or 5355	25.4	34000
51C-L	S-424	5100	3600 or 3000	S-4/524	5100 or 5355	25.4	34000
51L-M	S-524	5100	3600 or 3000	S-4/524	5100 or 5355	25.4	34000
	S-524-B4A	5100	3000	<i>Non-GE Gearbox, No Replacement Yet.</i>			
51M-R	S-624	5100	3600 or 3000	S-624	5100 or 5355	31.5	42242
51M-R	S-634	5100	3600 or 3000	S-634	5100 or 5355	31.5	42242
61A-B	S-644	5100	3600 or 3000	S-664/74	5100/5133	51.0	68365
61A-B	S-654A	5124	3600	S-654A	5124	no change	
61A-B	S-654B	5100	3000	S-654B	5100 or 5133	no change	
61A-B	S-664	5100	3600 or 3000	S-674	5133	51.0	68365
61B	S-674	5133	3600 or 3000	<i>Latest Design, No Uprate Available</i>			
7B	S-564-A	3615	3000	<i>No Replacement Yet Developed</i>			

The S-664/74 Are not Direct Replacements for the S-644. Modification is Required.

Figure 51. Load Gearbox Uprates

A continuously lubricated coupling is available for couplings located in high temperature environments. Either coupling design can be used to replace the “grease packed” or the “oil filled” couplings.

A new coupling will not necessarily solve a vibration problem. For load couplings on high speed compressor drives, a torsional and lateral analysis is recommended. GE can provide that analysis.

Load Gear FP4A, FP4D, FT3X and SSS Clutch

GE offers replacement load gears, many of which are tabulated on Figure 51. GE Lynn gearboxes were supplied on the GE produced MS5001 turbines. Since GE Lynn no longer produces gearboxes, GE has transferred the design to other suppliers, which have made modern improvements that enhance reliability, efficiency, and quietness. Replacement gearboxes can have higher torque ratings and different gear ratios. Non-GE gearboxes, and a few of the less common GE Lynn designs may require additional design cycle time and possibly an outage where the existing box is reversed engineered at the factory. The full set of instrumentation desired (proximity probes and thermocouples) should be explicitly specified with an order for a load gear.

The S-424, S-524, and S-624 uprated gearboxes have nitrided gear teeth and require higher oil flow, which is why they may have substantially higher nameplate ratings than the original gearboxes. The typical MS5001 aft stub shaft (integral with S2 wheel) has a load limit of 29.4 MW, so, to take advantage of the higher MW rating of the gearbox, a higher capacity aft stub shaft (31.5 MW) (FS2W) would be required. This would likely not affect operation in

temperate or hot climates.

The load gear in its entirety must be replaced. Gears alone should not be replaced, and so GE only offers full load gear assembly replacements. It is physically possible to replace the gears, rather than the whole assembly, however the added labor and installation complexity offsets any cost savings in material. Also, for increased torque rated gearboxes, there are other design changes besides the gears.

Most MS5001 and MS6001 GE, John Brown and Hitachi gearboxes can be replaced or modified to include a 170T SSS clutch. The SSS clutch permits the generator to act as a synchronous condenser during the off-peak loading time. No foundation work is required. Typically the SSS clutch will fit inside the present gearbox housing attached to the load-side quill shaft, but for some gearbox designs the SSS clutch may penetrate into the exhaust plenum to interfere with the drain piping. SSS clutches will not hurt the reliability of the gearbox. GE Power Systems Energy Consulting can do a grid analysis to identify which turbine generators benefit the grid most with VAR production.

Borescope Holes

Many MS5001 turbines were built prior to the existence of borescopes. Borescope holes can be added as on-site machining. The borescope holes include one on the 13th (MS5002) or 15th (MS5001) stage to inspect for FOD, and the others in the turbine section. If specified by the customer, the borescope holes are included with the on-site machining of the MS5001L-M casings for the new-tech S2 nozzle and/or tip-shroud bucket S2 shroud blocks.

Fan Driven Oil Demister FB2J

Many MS5001 turbine lube systems were supplied without a fan driven vent demister, but rather with a passive reservoir vent. It is important that the lube oil emissions do not enter the turbine inlet, where both the filter media and the compressor blades would get fouled due to the adhesiveness of the oil. GE offers the Lube Vent Demister module, which includes a motor driven blower. The demister will reduce oil emissions by coalescing the vapor-like mist and returning it to the lube reservoir. The blower has the secondary benefit of pulling a vacuum on the bearing cavities, which reduces or eliminates oil that may be leaking from the bearing seals.

A generic drawing depicting the suggested piping design and restrictions will be supplied.

Stage 16 Wheel

TIL-454A pertains to several MS5001 turbines having serial numbers between 179316 and 214292. If neither GE records nor site records indicate that the wheel has been replaced, then a replacement wheel should be made available the next time the rotor is removed.

Lube Oil Temperature

An MS5001 turbine may be experiencing hot oil temperature that limits output on hot days. As part of the overhaul for an uprate, the cooling system efficiency may have to be enhanced. The oil system and the water system are properly designed for the turbine even after the uprate, however, it is important to keep the components clean. The oil/water tube bundle heat exchanger and the air/water coolers should be refurbished at a properly equipped shop. Ensure the water divider plate in the oil/water heat exchanger has not pulled away from the tube sheet, or otherwise is bypassing water, and also ensure that no tubes are plugged with debris. The oil drain passage along the I-beam beneath the turbine should be well insulated.

For supplemental cooling for hot day peak power before the cooling system refurbishment, a kidney loop oil to air cooling circuit can be applied to the lube tank. If the water/air radiators are not repairable, or if additional cooling capacity is needed, a full capacity off-base fin-fan cooler can be applied. A fin-fan cooler for supplemental cooling might be better for black-start turbines to retain the shaft driven fan. A full capacity fin-fan module can be used for black start, but the hot-oil / hot-water restart capacity has to be factored into the design, plus a transformer for full-speed-no-load fan motor power, and other features for the diesel starting engine.

Lube Oil Quality

The MS5001 turbine lubrication oil experiences hard duty due to high temperature cycling and high loading in the gear with contamination due to the outdoor site conditions. Testing shows that the oil does not last the 30 years that is typical of steam turbine oil applications. During the overhaul to uprate the turbine, it is prudent to replace the oil, especially if the oil has not been replaced since the turbine was installed. The Failure Load Stage Test (FZB DIN-51354, A/8.3/90) that replaces ASTM D1947, shows that the load bearing capability of the oil varies with the RBOT number (ASTM D2272), such that when the RBOT has decreased to about 25% of its original value (to about 250 minutes oxidation life), then the oil needs to be replaced immediately to avoid a non-linear drop-off in its load carrying capacity. The highest quality oil for GE gas turbines conforms to GEK 101941, which is written for the MS6001FA turbine, and has an extra additive for gear service with high temperature. GEK 101941 provides information on the care of lube oil.

Exhaust Equipment

The exhaust plenum, expansion joint, and possibly the transition piece / silencer / exhaust stack on MS5001 turbines should be overhauled when the turbine is uprated. The mod per TIL-309 should be implemented. A replacement plenum from GE would be a solid panel design using SS409 along with an ASTM A36 structure. The solid panel design with ceramic insulation is much more robust and thermally effective than the perforated panel design of the original turbine equipment.

A loss of insulation in the exhaust plenum leads to misalignment: The excessive heat on the shaft and load area, and especially in the foundation cement, causes thermal growth that was not accounted for in the alignment. Any weld-repair done to Cor-Ten on the plenum or diffuser should be with weathering steel rod (example: 8018-W) rather than simple carbon steel.

Inlet Equipment

GE can provide a replacement inlet system consisting of (1) a static or self-cleaning inlet filter house, either in painted (inorganic zinc / epoxy) carbon steel or 304L stainless steel and/or (2) an inlet duct extending from the filter house's transition piece to the inlet plenum and possibly including the plenum's wings that extend down to the turbine base. The inlet duct can be painted steel or 304L stainless steel on the outside, and on the inside and for the silencers, the material can be either galvanized carbon steel or 304L stainless steel.

A proper functioning inlet system is important for maintaining the turbine's health, and is recommended for an uprated turbine. Good inlet filtration is an essential part of compressor cleanliness and is strongly recommended with GECC-1 coated compressor blades and vanes.

When replacing an inlet duct, consideration should be given to including an evaporative cooling section, or possibly having a section added as a provision for evaporative cooling.

Salt Contamination Prevention

Sites near the ocean typically have to take measures to prevent salt contamination. After salt is found on parts during inspections, it is evident that a Maintenance Factor greater than 1 should be applied until the contamination source is found and fixed. Liquid fuel salt contamination and other fuel quality problems harm hot gas path hardware, especially the last stage buckets. The corrosive effects of sodium/potassium with trace amounts of sulfur are given in GER 3569F.

Salt is typically introduced during the ocean tanker shipment process, but occasionally by handling and storage at site. One contamination event can cause substantial corrosion. The GE liquid fuel spec is GEI 41047H and recommendations for the storage of liquid fuel are in GEK 28163. Sodium in water and steam used for injection is another source of corrosive contamination, as is high sodium dusty soil in inlet air.

Sites near the ocean must take preventive measures against air-borne salt that is put into the atmosphere by surf. The inlet system design should be specifically intended for a marine environment. One preferred design is three-stage static inlet filtration system where a coalescing filter captures most of the air-borne salt and removes it through plastic frames to drain pans. The final (third) fine filter stage should be a marine environment media. All platforms, ladders and support structure should be hot dip galvanized. A 304L inlet house and 304L internally lined duct will extend the useful life of the equipment, compared to carbon steel. The recommended bird screen is 0.062" wire #2 mesh woven. A welded mesh will rust due to chrome carbide sensitization.

POWER AUGMENTATION

Power Augmentation is the term used to describe boosting the turbine output power by additional turbine massflow. Power augmentation is typically used to increase power on warm or hot days. A summary of power augmentation options on MS5001 turbines is given in Figure 52.

Most forms of power augmentation add steam

or water vapor to the turbine cycle. The steam or water must be clean to GE requirements which most importantly requires exceptionally low Na+K (for corrosion) and Ca (for hard deposits) content, as detailed in Figure 53. The media based evaporative cooler has a less stringent water cleaning requirement.

The additional water vapor in the combustor and turbine needs to be limited to the GE recommendation.

With any power augmentation or turbine uprate, the generator capability needs to be evaluated, and it would be prudent to check the duty cycle implied in the design of the load gear, generator, step up transformer, and all other equipment in the power transmission system. The generator may require additional cooling.

Steam Injection FJ3B, FG1B/F

Steam injection is the most complex, but also the most useful of power augmentation. It can be used in humid environments, where the evaporative cooler is nearly useless.

Steam injection "for NO_x" on an MS5001 utilizes nozzles on the combustion cover (Figures 54 and 55) that direct steam through the swirler into the flame, for controlled mixing and controlled NO_x emission.

Steam injection "for Power" on an MS5001 has the steam dumped into the compressor discharge casing, one connection per combustion case. Although about a third of the steam dilutes the flame, there is not controlled mixing so NO_x is not controlled.

A single pass boiler, typical of steam-for-NO_x injection, can be added to the exhaust stack for eight inches water column pressure drop, which creates a penalty of about -1.5% in output power and +1.5% in heat rate. Steam-for-Power injection would require a larger boiler.

Evaporative Cooling FD5A

Evaporative cooling reduces compressor inlet temperature for an increase in mass flow and output power. The benefit of evaporative cooling can be calculated from the psychrometric chart by following a constant enthalpy (wet bulb) line. Sample calculation: An 80% effective cooler on an 86 F day with 28 % humidity (63 F wet bulb, 48 F dew point) will cool the inlet air to 66 F. 66 F is the dry bulb for $28+0.8*(100-28)=85.6\%$ humidity at 63 F wet bulb. Figure 56 provides an estimate of the output power gain from an evaporative cooler.

Inlet moisture is generated with evaporative cooling and also with the inlet chiller. It is good practice to include a moisture separator, mist eliminator, or

<u>Water Injection</u>	<u>Steam Injection for NO_x</u>	<u>Steam Injection for Power Aug</u>	<u>Inlet Chilling</u>
NO _x to 42/65 ppm	NO _x to 42/65 ppm	1/3 of steam helps reduce NO _x	No NO _x Effect
Very Clean Treated Water	Clean Steam	Clean Steam	Not Applicable
Adv-Tech Combustion System, Atomizing Air for Distillate Fuel, Water Pump/Control Skid, Piping, Manifold, Nozzles, Controls	Adv-Tech Combustion System, Atomizing Air for Distillate Fuel, Control Valves, Piping, Manifold, Nozzles, Controls	Control Valves, Piping, Manifold, Nozzles, Controls	Inlet Duct Feature, Moisture Separator
CI MF increase to 2 (dry curve) Increased Dynamics HGPI/MI no change (dry curve)	CI MF no change (dry curve) Some increased dynamics HGPI/MI no change (dry curve)	CI MF no change (dry curve) HGP parts may run hotter HGPI/MI no change (dry curve)	No MF effect Don't cycle generator cooling HGPI/MI no change
No Ambient Restrictions	No Ambient Restrictions	59 F min due to PCD pressure	45 F minimum
<u>Evaporative Cooling</u>	<u>Inlet Fogging Evap Cooling</u>	<u>Inlet Fogging Overspray Intercooling</u>	
Some NO _x Reduction	Some NO _x Reduction		
Potable Water	Very Clean Treated Water		
Inlet Duct Feature, Moisture Separator Recommended	Inlet Duct Feature, Moisture Separator		
CI MF no change HGPI/MI no change	CI MF no change HGPI/MI no change	Not Recommended on MS5001 due to compressor erosion possibility	
59 F minimum ambient due to icing	59 F minimum ambient due to icing		

Figure 52. Power Augmentation Options for MS5001 Turbines

coalescing filter to reduce the liquid water carryover into the compressor inlet, however these devices add pressure drop, cost, and complexity.

Breech-Load Fuel Nozzle FR1T

The breech-load fuel nozzle is illustrated in Figure 57 and the traditional water injection nozzle design is illustrated in Figure 58. Breech-load fuel nozzles inject the water through the center of the fuel nozzle rather than from outside the fuel nozzle. As a result the water injection spray does not impinge on the fuel nozzle swirler and only a little if any water splashes on the combustion liner cowl assembly. The breech-load fuel nozzles will reduce or eliminate the combustion liner cap cracking typical of traditional water injection nozzles. This new design fuel/water nozzle will extend combustion system inspection intervals plus reduce downtime as well as repair costs.

The traditional water-injection fuel nozzles discharge water through 8 to 12 nozzles per combustor. The water is sprayed through the fuel nozzle tip swirl vanes before reaching the flame. Some of this water can splash on the liner cap, resulting in thermal fatigue and cracking. The combustion inspection intervals for gas turbines with standard water injection are shortened due to this cracking.

Extendor™ cannot address this failure mode.

The present GE recommendation is to have a CI every 8000 hours with a breech-load fuel nozzle with gas-only fuel.

For liquid fuel turbines, the atomizing air Boost Compressor is required to be uprated for the breech-load fuel nozzles. The modification may be as simple as an impeller upgrade. The main atomizing air compressor does not require uprating. Gas fuel-only turbines do not require atomizing air.

For water injection, the on-base piping is illustrated in Figure 59 and the water injection pump/control skid is illustrated in Figure 60.

The Effect of Additional Water Vapor on Turbine Hot Gas Path Parts.

Power augmentation, and especially water and steam injection, is limited by the effects of water vapor in the combustion process and in the turbine bucket/nozzle cooling process.

Often an operator will increase the amount of water or steam injection for NO_x beyond what is programmed into the controls, so that more power augmentation is obtained. In addition, an operator may desire to increase the amount of steam injection for power aug above the 5% of airflow maximum. This

over-injection of steam or water will increase the maintenance factors, and may also impact combustion dynamics levels and hardware durability.

Combustion. GE requires that the water vapor mass in the compressor discharge air be 5% maximum, which includes both ambient (or inlet) humidity (above the design humidity of 0.64% mass H₂O (60% rh at 15 C)) and injected steam or water (for a total humidity of 5.64% water vapor mass in air). This limit is derived from the flame stability requirement, but is also the limit to which the turbine section has been designed. Massive steam injection as offered for other turbine models, which is any amount above 5%, may be possible and would be evaluated on a case-by-case basis.

In the combustor, the water vapor cools the flame. The cooler flame is less forceful and so is less stable. A reduction in firing temperature aggravates this effect, and highly flammable fuels such as hydrogen lessen this effect. The lower flame stability causes an increase in combustor dynamics.

Water/Steam Quality	
Total Dissolved Solids	5.0 ppm Max.
Total Trace Metals (Sodium + Potassium + Vanadium + Lead)	0.5 ppm Max.
pH	6.5 - 7.5
Note: Quality Requirements Can Generally Be Satisfied by Demineralized Water	
Total Limits in All Sources Fuel, Steam, Water, Air	
Contaminant	Max Equivalent Concentration (ppm - wt)
Sodium + Potassium	1.0
Lead	1.0
Vanadium	0.5
Calcium	2.0

Figure 53. Water and Steam Quality Requirements

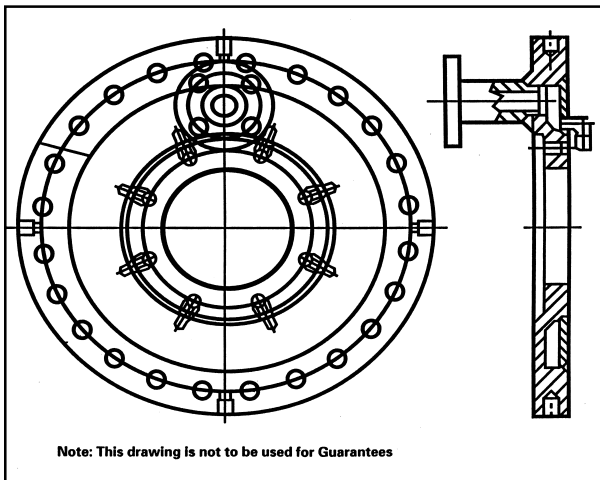

Figure 54. Steam Injection Nozzle System

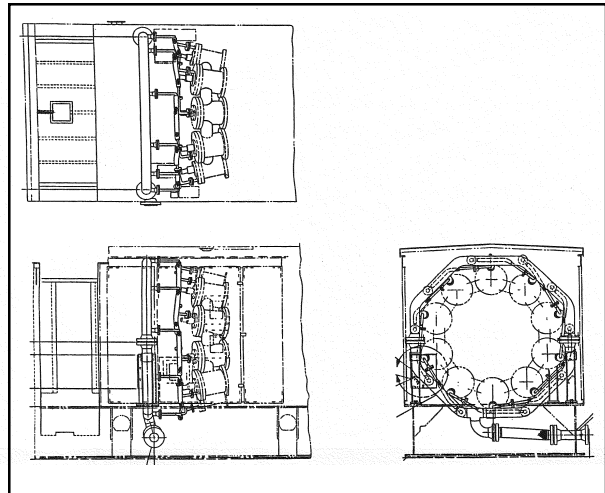

Figure 55. Steam for NO_x On-Base Piping

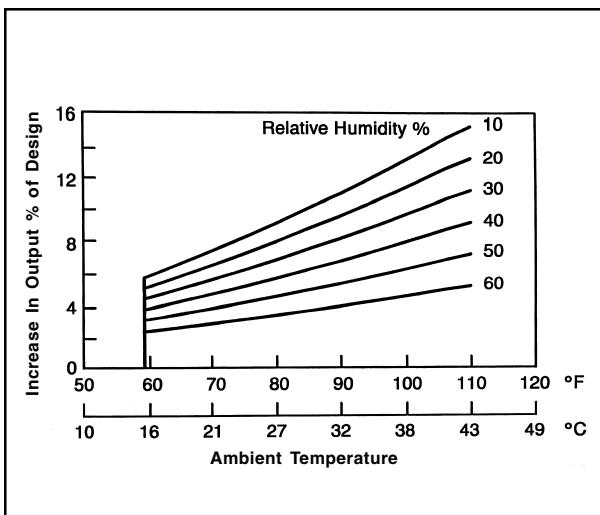

Figure 56. Evaporative Cooling Effectiveness

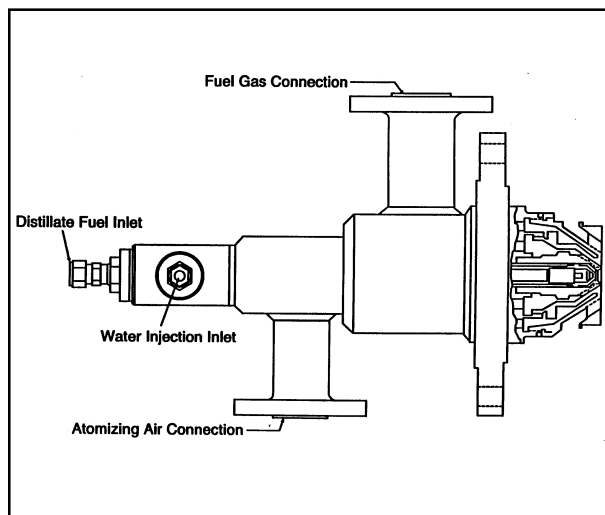

Figure 57. Breach Load Fuel Nozzle

With steam, the increase in combustor dynamics is linear with the amount of steam, but with water, it increases as the square of the water flow, due to boiling. Figure 61 illustrates this effect. Also, water splashes on the liner's cap and cylinder surface, causing thermal gradient induced cracking, so that a Combustion Inspection Maintenance Factor of 2 is associated with standard water injection. Breech-load fuel nozzles lessen the amount of splash, and restrict the splash to the cylinder surface of the liner.

A measurable indicator of flame temperature on an MS5001 simple diffusion combustor is NO_x emissions. When NO_x becomes too low, then dynamics could be too high.

Buckets/Nozzles. Water vapor is more thermally conductive than the other exhaust gas constituents. Additional water vapor from power augmentation causes higher convection coefficients and therefore hotter turbine bucket and nozzle metal temperatures on cooled components.

Higher metal temperatures would cause a decrease in the expected life, especially on an hours-limited (see GER 3620F) turbine. To retain parts life at the advertised level when there is high water vapor in the exhaust gas, the firing temperature is reduced. The firing temperature is reduced almost to the proper extent by retaining the exhaust temperature control curve that was originally intended for dry (non-augmented) operation.

The maintenance factor on the HGPI and MI would increase to 2 if the exhaust temperature is increased to retain the original firing temperature. The increased exhaust temperature control curve is called a wet control curve, an example of which is illustrated in Figure 62. This is likely a large cost for only a few hundred kilowatts on an MS5001, and so should only be applied when power is critically needed.

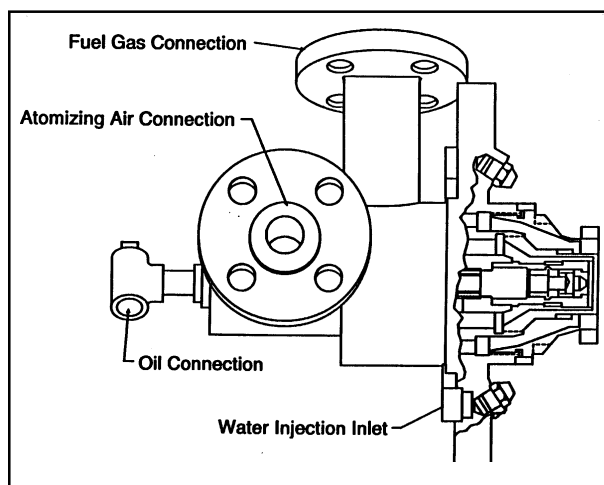

Figure 58. Traditional Water Injection Nozzle System

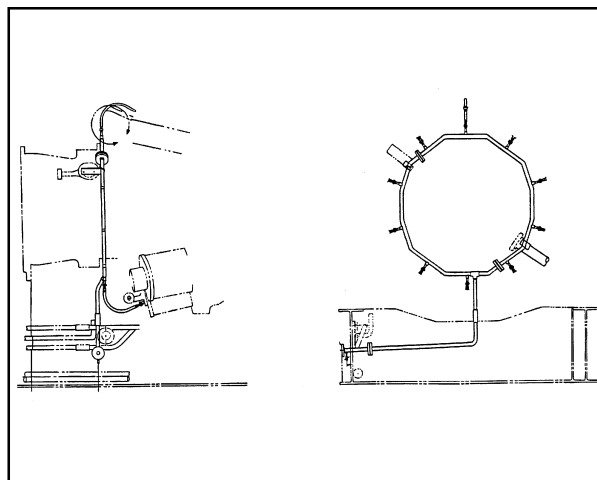

Figure 59. Water Injection Pipe On-Base Piping

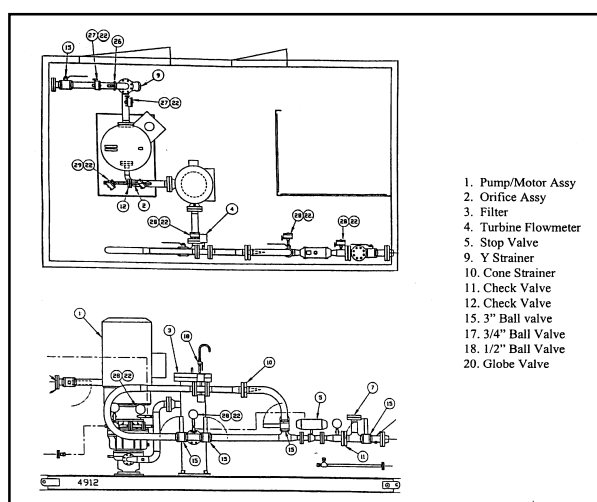

Figure 60. Water Injection Pumping and Control Skid

EMISSIONS FG1A, B, C, D, F, FR1B, FG2B

GE has developed several alternative methods for MS5001 NO_x control. Each method has restrictions, such as fuel type and atomization type, water or steam availability, and firing temperature range, as presented in Figure 63.

The Lean Head Low NO_x Combustion Liner is the most cost effective method of obtaining a substantial NO_x Reduction, and typically can counter the NO_x increase that would occur with a new-tech MS5001 uprate. The LHE liner is described in the "Advanced Combustion System" text above. When used in addition to a steam or water injection system, the LHE liner permits a reduction in steam or water injection.

Pre-mix combustion, such as DLN-1 as illustrated in Figure 64, has been successfully applied to three MS3002 turbines and two MS5001 turbines as aftermarket conversions as of 2000. DLN-1 premixes

gas fuel with air prior to combustion so that the NO_x are reduced. On dual-fuel turbines the liquid fuel generated NO_x would be reduced by water or steam injection. For more information on DLN, refer to GER 3568F.

GE continues to develop NO_x control methods for MS3000/5000 turbines to address the increasingly tighter regulations.

Emissions Estimates

NO_x estimates for MS5001A-M, R turbines are provided in Figures 65a and 65b. NO_x estimates for MS5001N-P turbines are provided in Figures 66a and 66b. The effect of modulating IGVs on MS5001N-P turbines is given in Figures 67a and 67b. Full load on the curves corresponds to a firing temperature that may be higher than the firing temperature on a particular turbine. In this case, full load for a particular turbine would correspond to a partial load condition on the curve.

The effect of shaft speed on MS5001A-M, R turbines is given in Figure 68. The effects of altitude are given in Figure 69. The effects of relative humidity and ambient temperature are given in Figures 70a and 70b. The critical parameter for humidity and temperature is the absolute humidity in the air flow. The water vapor added due to any evaporative cooling needs to be accounted for.

Atomizing Air FA6B

Many MS5001 turbines that burn liquid fuel have mechanical atomization rather than an atomizing air (AA) system. Atomizing air is required with liquid fuel for steam injection for NO_x and for water injection, for DLN, and also for dual fuel LHE liners. Therefore, for liquid fuel operation on MS5001 turbines, an atomizing air system is required for GE guaranteed NO_x control.

In addition atomizing air reduces the wear on turbine components by being a more dependable atomization process. Better atomization prevents burning in the stage 1 area, and more even combustion, can to can. A maintenance factor for more frequent inspections could be applied because of mechanical atomization, and would be best determined by reviewing the inspection history of the turbine.

An atomizing air system consists of a boost AA compressor, a main AA compressor, an air precooler, piping, manifold with pigtails, and fuel nozzles for atomizing air. Many non-GE-built MS5001 turbines have different accessory gearbox interfaces and so are not compatible with a GE AA compressor. Similarly, pre-1969 MS5001 turbines do not have an AA compressor shaft connection on the accessory gearbox. These turbines would need an off-base atomiz-

ing air system that is motor driven (about 300 hp). Black start turbines have the option of an accessory gearbox replacement or a diesel-generator set. Cooling water is required for the precooler. The additional heat load of the precooler is about 1/3 the existing heat load, and so it cannot be added to the existing turbine cooling water system without additional means to cool the cooling water.

REGENERATORS FT1H

A regenerator on an MS3000 or an MS5000 turbine provides approximately a 20% fuel savings, and so is an essential part of a turbine installation's competitiveness.

With today's modern design, as produced by GE Nuovo Pignone, the regenerator is highly reliable and long lasting with no availability penalty due to maintenance for at least fifteen years. Regenerators are best applied to compressor drive turbines because they are continuous duty (for shorter payback times) and typically do not have other heat recovery equipment. Utility electrical generation MS5001 turbines are typically cycled daily with fast starts, which are a little too aggressive in thermal differential expansion stress unless the starts are slowed down to two hours.

GE Nuovo Pignone uses the rotationally symmetric GEA regenerator design and has improved it with Nuovo Pignone's manufacturing techniques and material selections. With proper material selection, the regenerator is compatible with any fuel and with a marine or industrial environment.

GE Nuovo Pignone has built and installed several hundred regenerators in both new installations and simple to regen cycle conversions, with fleet leaders installed in 1980. The excellent field experience has proven the reliability of the GE Nuovo Pignone regenerator design and has proven out a simple maintenance schedule.

Application of a regenerator requires extensive reconfiguration of the site's balance of plant equipment. Even so, the payback period is short and depends on fuel price and operating hours. The efficiency gain due to a regenerator is illustrated in Figure 71, where MS5000 and MS3000 turbines have compression ratios typically below 11.

A regenerator is a heat exchanger that transfers exhaust heat to the turbine's compressor discharge air. The hotter compressor discharge air then requires less fuel when it is further heated to the firing temperature in the combustor. Regenerators are an effective way to recover the waste heat of the exhaust gas, and are ideal for unmanned sites because they are simpler than the boiler systems associated with cogen, steam injection, or combined cycle systems.

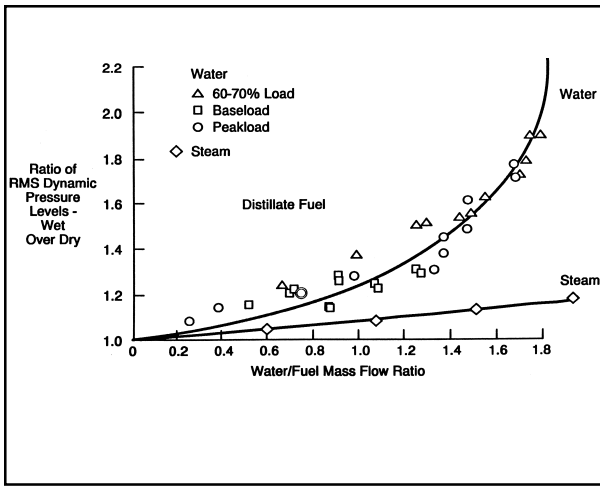

Figure 61. Combustor Dynamics for Water and Steam for NO_x Injection

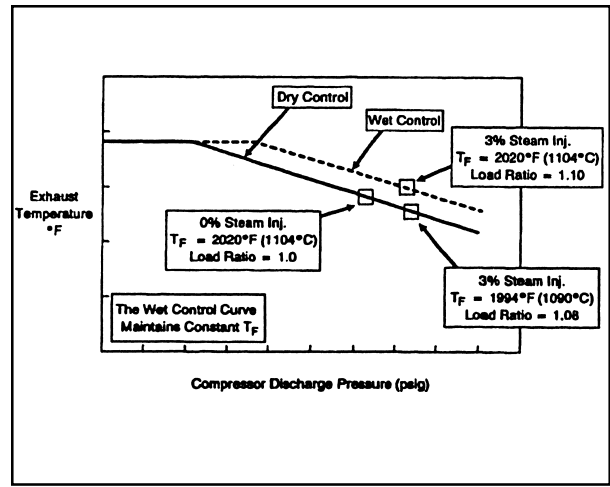

Figure 62. Wet and Dry Control Curve Example

Fuel Type	Low NO _x LHE Liner	Water Injection	For NO _x	Steam Injection For Power	DLN-1
Gas	30 % Less NO _x , MS5001M, R, P	42 ppm	42 ppm	Less NO _x	20 ppm 51P N/T 42 ppm 51R N/T
Gas/Oil, with Atomizing Air	15 % Less NO _x , Diluent for Oil	42/65 ppm	42/65 ppm	Less NO _x	same as above Diluent for Oil
Gas/Oil, no Atomizing Air	Not Applicable	Not Applicable	Not Applicable	Less NO _x	Not Applicable
Oil, with Atomizing Air	Not Applicable	65 ppm	65 ppm	Less NO _x	Not Applicable
Oil, no Atomizing Air	Not Applicable	Not Applicable	Not Applicable	Less NO _x	Not Applicable

"ppm" in this table refers to the units of "ppmvd NO_x at 15% O₂"

Figure 63. NO_x Abatement Systems For MS5001 Turbines

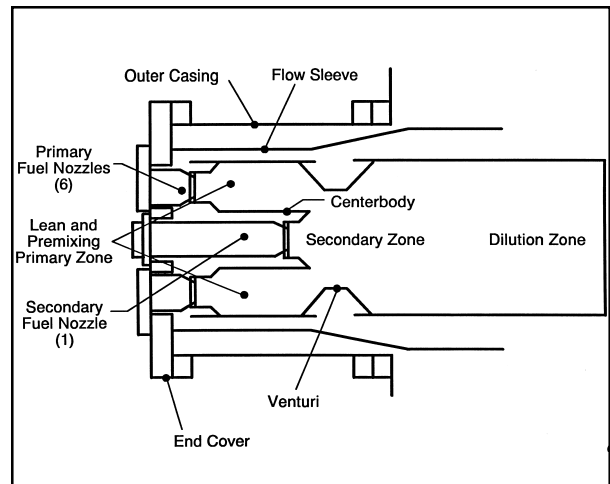

Figure 64. DLN Combustor

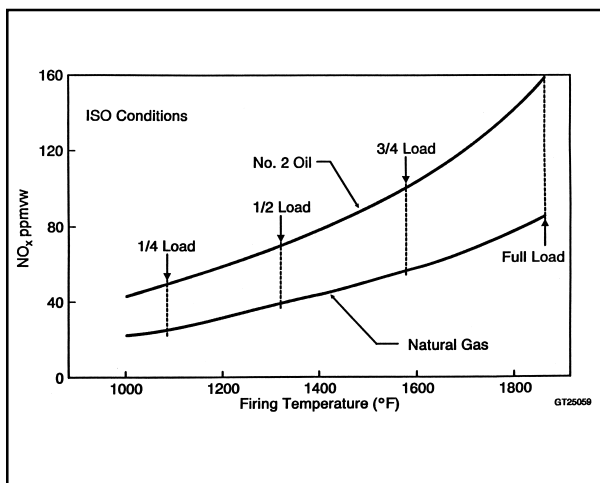

Figure 65a. Estimated NO_x Emissions for MS5001A-M, R Turbines (1)

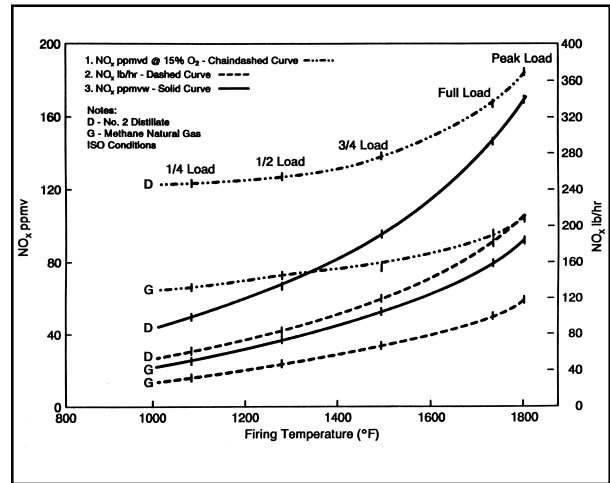

Figure 65b. Estimated NO_x Emissions for MS5001A-M, R Turbines (2)

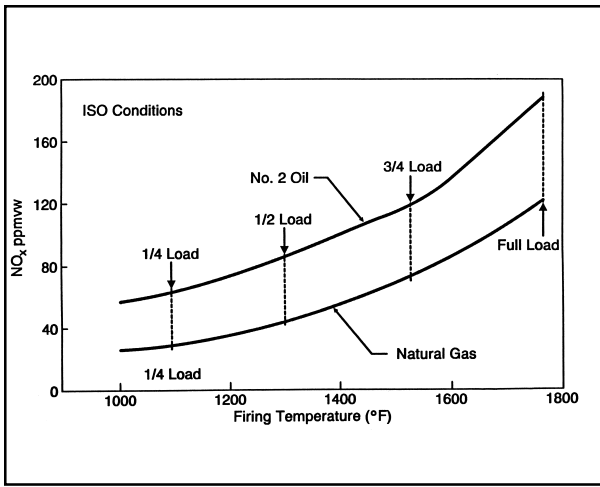

Figure 66a. Estimated NO_x Emissions for MS5001N, P Turbines (1)

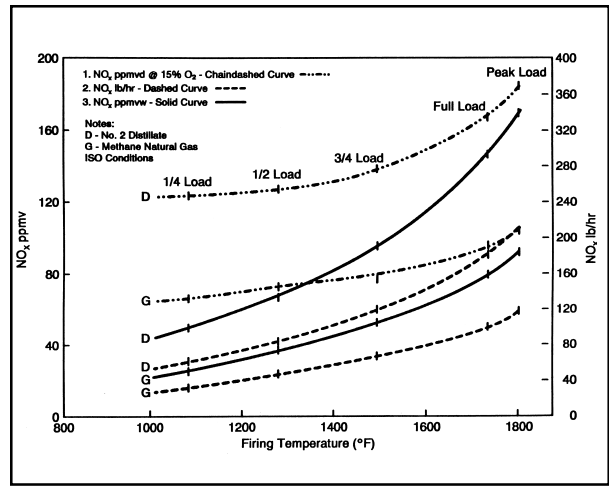

Figure 66b. Estimated NO_x Emissions for MS5001N, P Turbines (2)

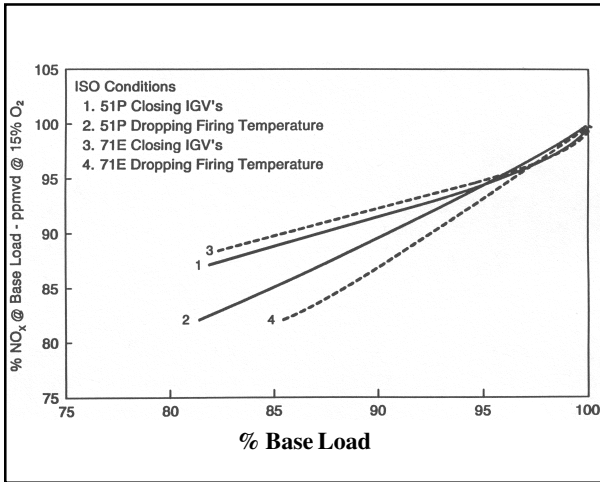

Figure 67a. Modulating IGV Effect on Emissions (1)

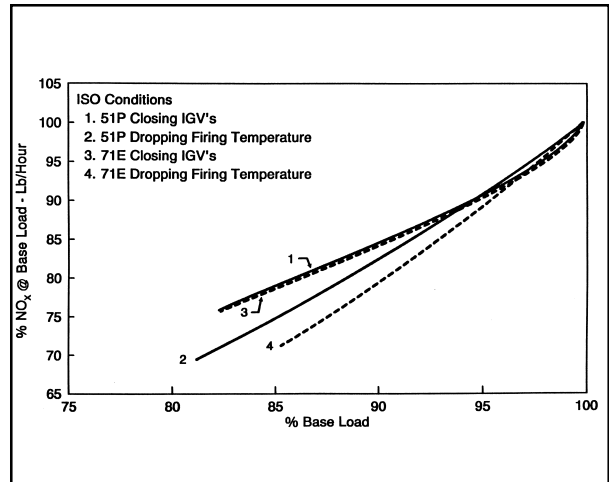

Figure 67b. Modulating IGV Effect on Emissions (2)

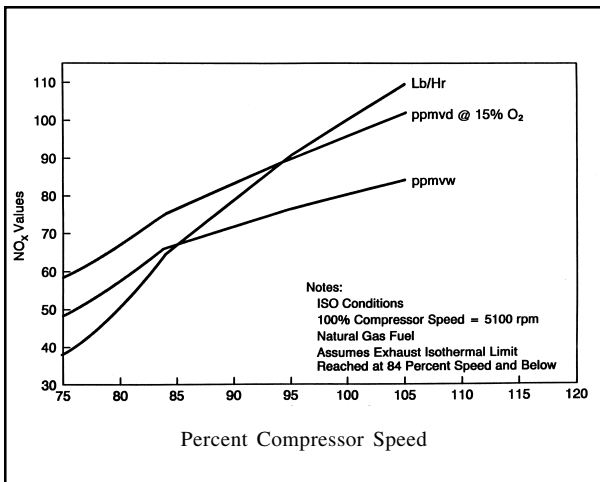

Figure 68. MS5001A-M, R NO_x Emissions vs. Shaft Speed

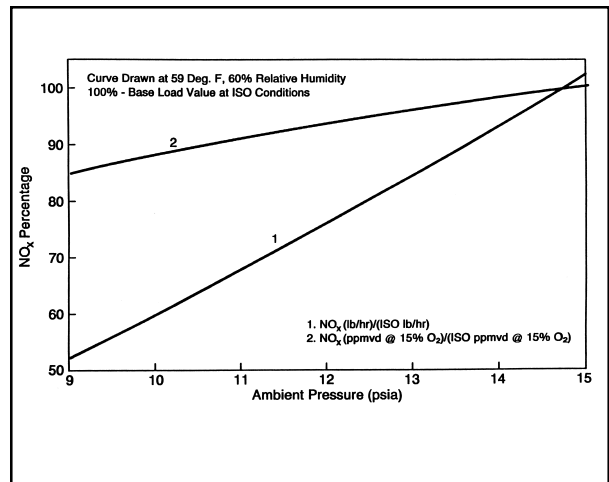

Figure 69. Altitude Effect on NO_x Production

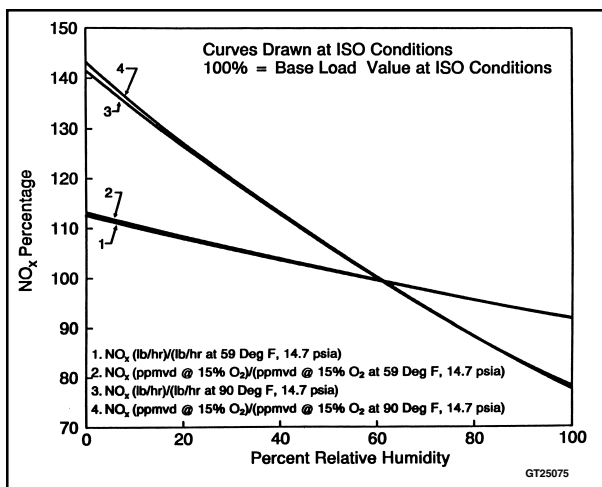

Figure 70a. Relative Humidity Effect on NO_x Production

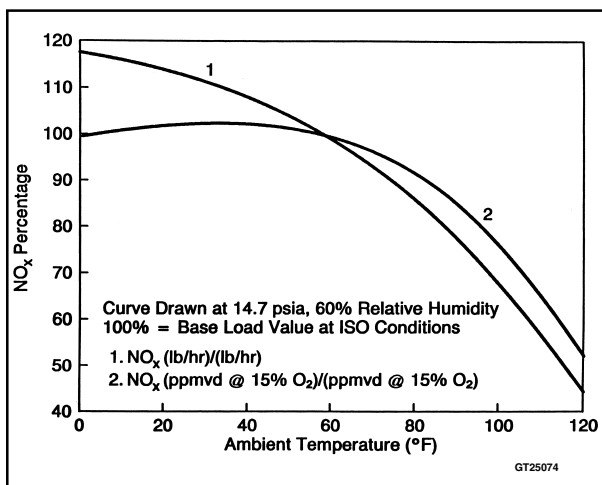

Figure 70b. Ambient Temperature Effect on NO_x Production

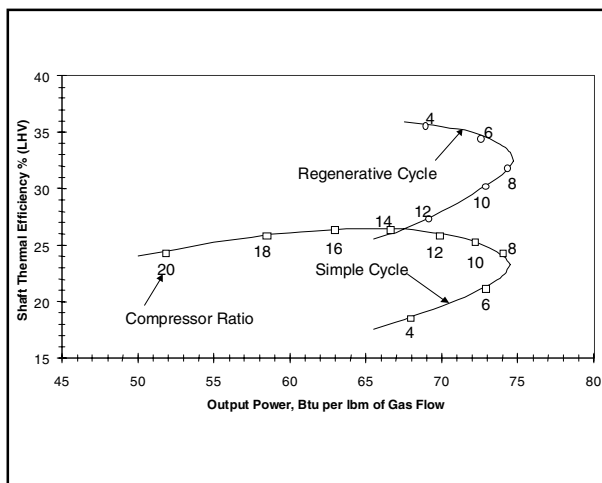

Figure 71. Regenerator Benefit for Heat Rate (Pressure Ratio on Curves)

Regenerative cycle fuel efficiency remains high at partial loads on MS5001N, P and MS5002B, C turbines when the IGVs modulate air flow, so that exhaust temperature is maximized. Also, the regenerative cycle partially compensates for compressor degradation. The thermodynamic cycle of MS3000 and MS5000 turbines works well with a regenerator, and so GE designed those turbines to be compatible with a conversion from simple cycle to regen cycle, especially the MS3002/5002 turbines.

The technology of regenerators is now firmly established. During the 1960s and 1970s, when most MS3000 and MS5000 turbines were built, the regenerator technology was less reliable, so MS3000 and MS5000 turbines were typically simple cycle rather than regen cycle.

The installation of a regenerator onto a presently simple cycle turbine requires turbine modifications and so should be performed concurrent with a major overhaul. The GE / GE Nuovo Pignone team has conversion kits for MS3002 and MS5002 turbines. A kit will be developed for the MS5001 when one is converted, and will be based on our MS5001LA turbines that were delivered new as regen cycle. For an MS5001 turbine, the major change to the turbine itself is that the compressor discharge casing and combustion system and turbine shell must be replaced, as well as a combustion wrapper added. Atomizing air for liquid fuel is required, and the combustion design effort for liquid fuel will be greater than for gas fuel. The kit can include any of a wide variety of additional upgraded hardware: for maintained or lower emissions, for maintained or greater output power, and for more reliability/maintainability.

The installation of a GE Nuovo Pignone regenerator onto an existing site, either a simple cycle site or a competing technology regenerator site, requires the regenerator/piping installation be contracted to GE Nuovo Pignone. The piping design, turbine enclosure design, and regenerator design is integrated with the installation procedure. So, to avoid discontinuities between the design and installation phase, it is critical to have both tasks assigned to the same contractor, especially to a contractor who specializes in simple-to-regen conversions, like GE Nuovo Pignone.

There are two basic layouts of an MS5000 regenerator system: symmetric and non-symmetric. The non-symmetric is often preferred because it leaves one side of the turbine uncluttered as a work area during overhauls. The compressor discharge piping from that side needs to be routed to the other side, which would possibly have to go over the turbine on a simple to regen conversion. The piping would be easily detachable for turbine maintenance.

GE Nuovo Pignone regenerators:

- About 18% heat rate improvement. About a two year payback.
- Little if any impact to the turbine maintenance schedule. Axial symmetric GEA design with Nuovo Pignone improved manufacturing and materials.
- Over 200 installed, half are over 15 years installed, half were installed as simple to regen conversions.
- Simple to regen conversions: Full scope turn-key project with GE Nuovo Pignone and GE Energy Services. Installation outage time can be minimized to about four weeks.
- The NO_x increase can be controlled, and the power loss can be regained, with uprated parts and controls.

A GE PERFORMANCE GUARANTEE FT9A, FT9B

The MS5001 uprates have a history of making the performance as estimated or as guaranteed. There are hundreds of customers who have had the different GE uprate offerings. Therefore, there is confidence that actual performance will be as estimated in a GE quote. It is good marketing for GE to continue to ensure that the uprated turbines meet the estimated or the guaranteed performance values.

If GE were to guarantee a performance impact for an uprate, then additional research into the turbine as well as before and after testing would be required. Performance guarantees are given as a delta increase, or a percent increase. This method, as opposed to absolute numbers, diminishes the importance of degradations that have previously occurred to the turbine, such as airfoil surfaces and edges being roughed up, tip rubbing and casing out of roundness, clearances opening and seal wear, and to some extent, the effect of inlet and exhaust equipment.

The delta guarantee is useful in erasing the effect of degradations. If a long time passes between the before and after testing, then a correction factor for the predictable non-recoverable degradation will be applied to compensate for degradation that occurred between the two tests.

Small uprates, typical of component changes such as advanced seals, have performance gains of the same magnitude of the test tolerance.

It is possible for GE to make an absolute guarantee of performance for a new-technology uprate, but only for the MS5001R N/T or MS5001P N/T configuration as given in Figure 72a and 72b. For an

absolute guarantee, the compressor would require reblading or else hand or CO₂ blast polishing and the #1 bearing leak repaired if leaking, the HPP and other seals would require refurbishment, the casing roundness at the S1 bucket compensated for (preferably by coated S1 shroud blocks), and there would be other conditions as specified.

With any performance guarantee, the project scope needs to include the performance testing by GE, GE Technical Direction during the installation and start-up, and other conditions that will be specified by the GE application engineer. Non-GE parts cannot be installed in the turbine if there is a performance guarantee.

EVALUATION OF THE GENERATOR

A generator will generate electricity that matches the torque being supplied by the turbine. If the turbine supplies more power than the generator was designed for, then the generator will overheat due to excessive copper I²R losses and laminate eddy current losses. Therefore, the turbine capability, or at least the turbine controls, must limit turbine output to a value that the generator can convert to electricity without overheating.

Many generators have a nameplate kW rating that is higher than the associated turbine nameplate kW rating given a properly corresponding cooling medium temperature. For these generators, the proposed turbine uprate might have no issue relative to the generator if the uprated turbine kW's would not exceed the generator kW capability everywhere in the ambient temperature range.

Most generators were designed with a conservative power factor. The power factor is the measure of the mathematically-imaginary reactive power, which is a measure of how far out-of-phase the armature current is from the armature voltage. If a generator is operating at 0.95 power factor (0.95 = cosine (18 degrees out of phase)) and it is designed for 0.85 power factor, then there is additional generator kW capability of $0.95/0.85 - 1 = 11.7\%$.

If the generator does operate at a less severe power factor than originally rated for, then that margin can be applied to the turbine uprate. The proposed turbine uprate has no issue relative to the generator if the generator nameplate kVA rating would not be surpassed after the turbine uprate, even if the turbine kW goes beyond the generator kW rating. The whole ambient temperature range should be evaluated.

Excess power factor capability is important for the health of the grid, so other parties may want to know if the power factor margin is being taken up in

Generator Drive**

Advanced Technology Uprate Model	Firing Temp °F/ °C	Output kW*	Heat Rate Btu/kW-hr*/ kJ/kWh	Exhaust Flow 10 ³ #hr/ 10 ³ kg/hr	Exhaust Temp °F/ °C	Comments
MS5001R - N/T	1755/957	19,800	13,250/13,976	774.6/351	975/524	-
MS5001P - N/T	1765/863	25,240	12,430/13,111	952.1/432	924/496	Axial Strut (Pre 1978)
MS5001P - N/T	1765/963	25,720	12,110/12,774	949.1/431	919/493	Rotated Strut (Post 1978)
MS7001B/E (#1)	1840/1004	60,910	11,020/11,624	2040/925	911/488	Option #1
MS7001B/E (#2)	1905/1041	63,500	11,100/11,708	2041/926	954/512	Option #2
MS7001B/E (#3)	1965/1074	67,140	11,010/11,613	2042/926	990/532	Option #3
MS7001B/E (#4)	2020/1104	70,540	10,940/11,540	2043/927	1024/551	Option #4
MS7001E	2020/1104	77,840	10,830/11,423	2299/1043	1000/538	-
MS7001E	2035/1113	78,810	10,820/15,308	2299/1043	1010/543	-
MS7001EA	2035/1113	81,950	10,690/15,124	2365/1073	997/5346	-
MS9001B/E (#1)	1840/1004	87,960	11,000/11,600	2938/1332	911/488	Option #1
MS9001B/E (#2)	1905/1041	93,270	10,940/11,540	2939/1333	954/512	Option #2
MS9001B/E (#3)	1965/1074	97,600	10,900/11,500	2940/1333	990/532	Option #3
MS9001B/E (#4)	2020/1104	102,580	10,830/11,420	2942/1334	1024/551	Option #4
MS9001E	2020/1104	114,610	10,520/11,100	3316/1504	982/528	-
MS9001E	2055/1124	119,380	10,400/11,000	3317/1504	1004/540	-

* All Uprates Are Based on Using Reduced Camber High Flow IGVs

** All Uprate Performance is Based on ISO (59 ° F/16°C, Sea Level, 0"/0" Inlet/Exhaust Pressure Drops, 60% Relative Humidity) Natural Gas Fuel, Base Load and Assumes Axial Flow Compressor is Not Rebladed.

Figure 72a. Absolute Guarantees for Generator Drive Turbines

Mechanical Drive**

Advanced Technology Uprate Model	Firing Temp °F/ °C	Output HP/kW	Heat Rate Btu/kW-hr/ kJ/kWh	Exhaust Flow 10 ³ #hr/ 10 ³ kg/hr	Exhaust Temp °F/ °C	Comments
MS3002F - N/T	1643/895	11,590/8,643	11,140/15,761	410.5/186	980/527	Simple Cycle
MS3002F - N/T	1628/887	10,620/7,919	8,160/11,545	410.5/186	605/318	Regen Cycle
MS3002 A-F	1575/857	9,700*/7,233	-	379*/172	-	Simple Cycle
MS3002 A-F	1625/885	9,400*/7,010	8,450*/11,955	379*/172	-	Regen Cycle
MS3002J - N/T	1770/966	15,140/11,290	9,500/13,441	415/188	1008/542	Simple Cycle
MS5002A - N/T	1745/952	27,130/20,231	9,940/14,063	776.1/352	1016/547	Simple Cycle
MS5002B - N/T	1770/966	36,000/26,845	9,150/12,945	974.4/442	967/519	Simple Cycle
MS5001R - N/T	1755/957	26,080/19,448	9,700/13,724	735.2/333	987/531	Simple Cycle

* MS3002A-F Uprates Are Based On NEMA Conditions, All Other Numbers Are At ISO Conditions

** All Uprates Are Based On Using Reduced Camber High Flow IGVs

Figure 72b. Absolute Guarantees for Mechanical Drive Turbines

an uprate. It is typical for the older generators at a site or on a grid to operate with power factor near 1, and the newer generators to carry the reactive power load. Also, the reactive load can be removed by installing a shunt capacitor bank or synchronous condenser near the reactive load source. GE Energy Services Energy Consulting can analyze a grid to

determine where reactive load compensation equipment should be placed.

For an open ventilated generator, which uses ambient air directly to cool its internal components, it is typical for the generator to have more kW margin on hot days, and less on cool days, relative to the turbine. So, below a specific ambient temperature,

**What CM&U's are Under Consideration
Turbine Model and Serial Number**

What is Site Critical: Output Power on Hot Days, Fuel Consumption, Maintainability, Reliability, Overhaul Outage Time, Overhaul Hardware Shipment Date

Loading: Continuous or High Cycle; Manned or Unmanned Site

Fuel: Natural Gas, Process Gas, Distillate, Heavy Ash Fuel, Combinations

What Power Augmentation or NOx Abatement Equipment is Installed

What Control System is Presently Installed, Control Curve

Important Modifications That Have Occurred to this Turbine

Maintenance or Operator Contact, Name and Phone Number

Should the Compressor be Rebladed; What non-GE Hardware is Installed

Is Clean Water or Steam Available, Is there Heat Recovery Equipment

Are the Inlet and Exhaust Systems in Good Shape including Exhaust Frame/Diffuser

How is the Turbine Cooling Water Cooled

Turbine Starter (Motor / Diesel / Steam Turbine / Gas Expansion Turbine)

Load Coupling, Load Gear, Generator, and Turbine Nameplate Information.

Ambient Temperature and Humidity Range, Altitude, Contamination in Inlet Air

Company that Manufactured the Turbine

Figure 73. MS5001 Turbines, Information for an Uprate Study

the turbine control must suppress some of the potential turbine output by reducing firing temperature or airflow. This may be acceptable where hot day power is most critical.

If the proposed uprate pushes the generator beyond its nameplate kVA rating, then there are several options that a GE generator application engineer can consider. Alternatively, the generator/loadgear can be replaced.

Data from the field indicates that generators that are 25 to 30 years old or older are beginning to experience reliability problems due to insulation degradation. A rewind should be considered. GE provides this service for both GE and non-GE generators. After a turbine uprate, there would typically be more kVA's generated by the generator, which might reduce reliability if the generator insulation is over 25 to 30 years old. GER 3707 provides information on Generator Uprates and Rewinds.

The estimated output power increase of an MS5001 due to a new-tech uprate or advanced seals is a minimum estimate. Given compressor reblading, SIS abraidable coating, good alignment, and/or careful attention to part fits and other leakage paths by the overhaul team, it is possible that the turbine can produce 2 MW additional output power. The generator capability evaluation should take this into account.

INITIATING AN UPRATE STUDY OF A TURBINE

GE provides the service of having an engineer review a turbine that is being considered for a conversion, a modification, or an uprate (CM&U). To begin the process, the customer should contact the local GE sales office. If the customer does not know how to contact GE, then the customer may contact GE Energy Services in Atlanta directly (1 800 4GE FAST). Contact the local GE sales office at least a month before replacement parts for the outage would be ordered.

GE records provide the GE engineer with original order information as well as data on GE provided modifications. However, it is beneficial if the customer or the local GE office provides to GE application engineering critical turbine and load information as given in Figure 73.

SUMMARY

GE offers a comprehensive set of offerings for MS5001 turbines. All features of the turbine can be replaced, upgraded or modified. A turbine can be uprated to a performance level that is substantially better than when it was originally purchased.