

# IGV RACK & CONTROL RINGS

Applicability:  
9E / 7E / 9F / 7F  
(except 7F.05)

IGV gear and rack actuation systems are equipped on GE Vernova's E-Class and F-Class (except 7F.05) heavy duty gas turbines. Maintaining IGV's and the actuation system in good order is essential to support safe and reliable compressor operation. As 50 and 60Hz E and F-Class gas turbine fleets age, increased wear of IGV and Control Ring gears can be observed.

Considerations for wear may include:

- Gas turbine operation > 20 years
- Changes in plant mission from base load to more cyclic operation
- Use of grease can increase dust accumulation which in turn increases the wear mechanism (grease is not a recommended GE solution)
- Refer to TIL 2363 for Rack and Control Ring Maintenance guideline

## Component Impact:

- Excessive wear on IGV Rack and Control Ring can create negative consequences to the IGV gears backlash. If left uncorrected, out-of-tolerance backlash can increase vibratory motion of the IGV which may lead to cracking of IGVs and gears

## Recommended Solution:

- Inspect the IGV gears and rack for wear or corrosion and replace the Rack and Control Ring when necessary
- Safety stock for IGV Rack and control rings at site avoids waiting time and helps ensure quick replacements when an issue is identified

## Expected Benefits:

- Replacement of control rings maintains the expected lifetime of the IGVs and gears to specifications
- Identifying minor damages and replacing parts helps eliminate the need to re-calibrate backlash at each inspection, reducing outage cost and time by up to one shift of 12 hours for three mechanics during the outage.

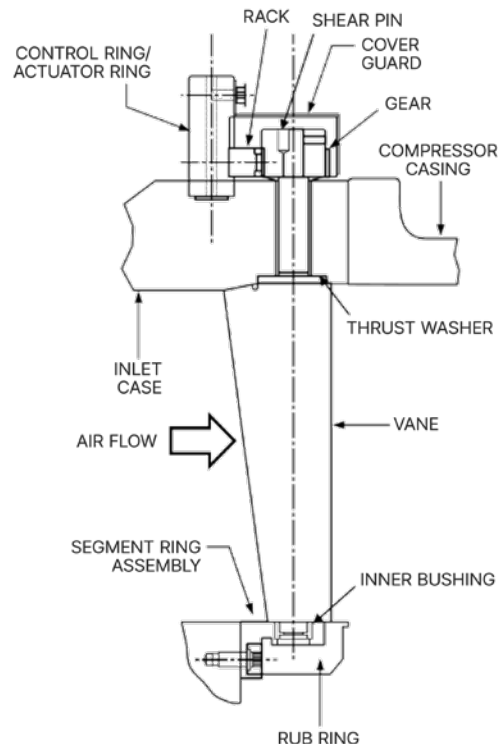

TO LEARN MORE ABOUT THIS OFFERING,  
CONTACT YOUR SALES REPRESENTATIVE  
OR VISIT

[governova.com](http://governova.com)

Information contained in this document is indicative. No representation or warranty is given or should be relied on. Information provided is subject to change without notice.

© 2025 GE Vernova and/or its affiliates. All rights reserved.  
GE and the GE Monogram are trademarks of General Electric Company used under trademark license.

GEA35266 (12/2025)



GE VERNOVA