



# Forced-air Cooling System

## Forced-air cooling system for industrial steam turbines

GE offers an innovative forced-air cooling system for GE and non-GE turbines, able to improve availability of the unit by reducing the outage duration.

### Availability and Flexibility Improvement

Based on a broad experience on Industrial Steam Turbines (ISTs), GE offers a standardized solution for controlled/accelerated unit cool-down, widely applicable to all GE and non-GE fleets and able to achieve cool-down time reduction up to 50%, compared to natural cooling. This solution allows increased availability and flexible outage execution, fulfilling the requirements of modern power generation or industrial plants and helping to ensure the overall unit profitability.

### Background

From an operators point of view, the time it takes from live steam valves closure to the moment when disassembly activities commence, should be as short as possible. However, the current experience on ISTs shows that the cool-down of the turbine can take up to 3 days.

The common practice of reducing live steam temperature before closing the live steam valves is not always feasible or practical on ISTs because of either unplanned trip events, boiler collector systems, specific industrial processes or outdated boiler technology.

### Solution

In order to achieve an accelerated cooling down time improving the unit profitability, GE has developed a mobile and scalable hardware which provides cooling air from the external environment.

#### Blower skid

The blower skid is assembled on a mobile support which allows to use a single system to provide forced cooling air to different turbines in the plant, if desired. A fan, driven by an electric motor conveys the cooling air, after filtering, into a duct (Fig. 1). The interfaces between skid and turbine inlet are customized by means of flexible hose and flanges.

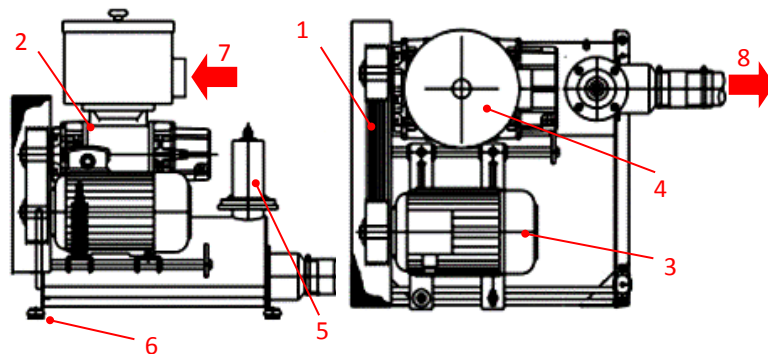

- |                           |                           |
|---------------------------|---------------------------|
| (1) Blower belt drive     | (5) Control Valve         |
| (2) Blower                | (6) Shock insulation feet |
| (3) Electric motor        | (7) Air intake            |
| (4) Inlet silencer/filter | (8) Air outlet            |

Fig. 1: drawing of the blower skid and list of its main components

#### Layout

The forced-air cooling is based on the counter air flow (see Fig.2), where the cooling air enters the steam turbine from the low pressure section. The blower skid is connected to the turbine casing via a flexible hose, which can be connected to any inlet port available:

- Vacuum breaker valve (preferred choice)
- Steam turbine exhaust man hole
- Exhaust casing drain connection
- Connection to the vacuum group
- Other free flanges in the condenser

The cooling air is then removed through outlet ports which can be

- Blow out pipe (preferred choice)
- Pre-warming lines
- Drains upstream of the emergency stop valves

Potentially, some project specific modifications of the P&ID may be required for non-GE units.

The following optional services are available:

- Air conditioner (for units operating in hot/cold locations)
- Anechoic chamber (noise reduction below 76 dB(A))
- ATmosphères EXplosibles (ATEX) certification

Analysis

3D FE thermal and structural assessments have been carried out for the steam turbine (Fig. 3) to verify:

- Cool down time
- Avoidance of rotor and blade rubbing
- Mechanical integrity and low cycle fatigue (LCF)

5h forced cooling

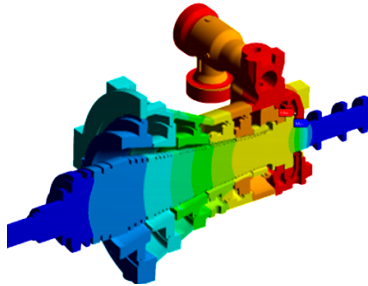

25h forced cooling

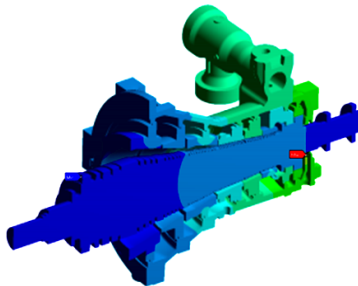

Fig. 3: 3D Thermal distribution during cool down

Benefits

- Improvement of overall unit profitability
- Reduced outage duration  
Up to 50% reduction of cool-down time compared to natural cooling.
- Fully mobile solution  
The complete system is assembled on a mobile support which can be lifted at a single point, carried with a fork lift or even pushed on wheels. As a result, one device could be used on different ISTs in the plant.
- Scalable to volumetric cooling flow requirements

Applicability

The forced-air cooling system can be applied to nearly all the medium and large size ISTs, both GE and non-GE technology.

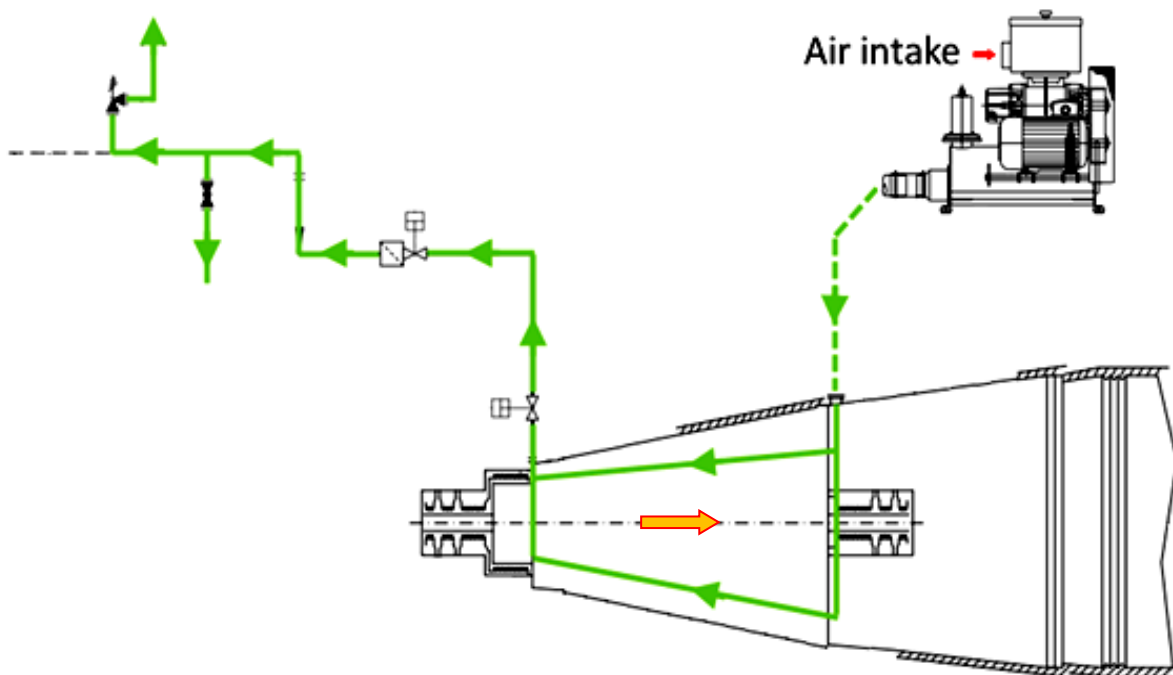

Fig. 2: Counter air flow path