

10

A-C GENERATOR AND MOTOR PROTECTION

The remaining chapters deal with the application of protective relays to each of the several elements that make up the electric power system. Although there is quite good agreement among protection engineers as to what constitutes the necessary protection and how to provide it, there are still many differences of opinion in certain areas. This book describes the general practice, giving the pros and cons where there are differences of opinion. Four standard-practice publications deal with the application of protective relays.^{1,2,3,4} Manufacturers' publications are also available.^{5,6,20} Bibliographies of relaying literature prepared by an AIEE committee provide convenient reference to a wealth of information for more detailed study.⁷ Frequent reference will be made here to publications that have been found most informative.

The fact that this book recognizes differences of opinion should not be interpreted as complete approval of the various parallel practices. Although it is recognized that there may sometimes be special economic and technical considerations, nevertheless, much can still be done in the way of standardization.

GENERATOR PROTECTION

Except where specifically stated otherwise, the following will deal with generators in *attended* stations, including the generators of frequency converters.

The protection of generators involves the consideration of more possible abnormal operating conditions than the protection of any other system element. In unattended stations, automatic protection against all harmful abnormal conditions should be provided.¹ But much difference of opinion exists as to what constitutes sufficient protection of generators in attended stations. Such difference of opinion is mostly concerning the protection against abnormal operating conditions, other than short circuits, that do not necessarily require the immediate removal from service of a machine and that might be left to the control of an attendant.

The arguments that are advanced in favor of a minimum amount of automatic protective equipment are as follows: (*a*) the more automatic equipment there is to maintain, the poorer maintenance it will get, and hence it will be less reliable; (*b*) automatic equipment might operate incorrectly and trip a generator undesirably; (*c*) an operator can sometimes avoid removing a generator from service when its removal would be embarrassing. Most of the objection to automatic protective equipment is not so much that a relay will fail to operate when it should, but that it might remove a generator from service unnecessarily. Part of the basis for this attitude is simply fear. Each additional device adds another

contact that can trip the generator. The more such contacts there are, the greater is the possibility that one might somehow close when it should not. There is some justification for such fears. Relays have operated improperly. Such improper operation is most likely in new installations before the installation “kinks” have been straightened out. Occasionally, an abnormal operating condition arises that was not anticipated in the design or application of the equipment, and a relay operates undesirably. Cases are on record where cleaning or maintenance personnel accidentally caused a relay to trip a generator. But, if something is known to be basically wrong with a protective relay so that it cannot be relied on to operate properly, it should not be applied or it should be corrected one way or another. Otherwise, fear alone is not a proper basis for omitting needed protection.

Admittedly, an alert and skillful operator can sometimes avoid removing a generator from service. In general, however, and with all due respect to operators, the natural fear of removing a machine from service unnecessarily could result in serious damage. Operators have been known to make mistakes during emergencies and to trip generators unnecessarily as well as to fail to trip when necessary.⁸ Furthermore, during an emergency, an operator has other important things to do for which he is better fitted.

An unnecessary generator outage is undesirable, but one should not try to avoid it by the omission of otherwise desirable automatic protection. It is generally agreed that any well-designed and well-operated system should be able to withstand a short unscheduled outage of the largest generating unit.⁹ It is realized that sometimes it may take several hours to make sure that there is nothing wrong with the unit and to return it to service. Nevertheless, if this is the price one has to pay to avoid the possibility of a unit's being out of service several months for repair, it is worth it. The protection of certain generators against the possibility of extensive damage may be more important than the protection of the service of the system.⁹

The practice is increasing of using centralized control, which requires more automatic equipment and less manual “on the spot” supervision, in order to provide higher standards of service with still greater efficiency.¹⁰ Such practice requires more automatic protective-relaying equipment to provide the protection that was formerly the responsibility of attendants.⁸

SHORT-CIRCUIT PROTECTION OF STATOR WINDINGS BY PERCENTAGE-DIFFERENTIAL RELAYS

It is the standardized practice of manufacturers to recommend differential protection for generators rated 1000 kva or higher,² and most of such generators are protected by differential relays.¹¹ Above 10,000 kva, it is almost universally the practice to use differential relays.⁹ Percentage-differential relaying is the best for the purpose, and it should be used wherever it can be justified economically. It is not necessarily the size of a generator that determines how good the protection should be; the important thing is the effect on the rest of the system of a prolonged fault in the generator, and how great the hardship would be if the generator was badly damaged and was out of service for a long time.

The arrangement of CT's and percentage-differential relays is shown in Fig. 1 for a wye-connected machine, and in Fig. 2 for a delta machine. If the neutral connection is made inside the generator and only the neutral lead is brought out and grounded through low

impedance, percentage-differential relaying for ground faults only can be provided, as in Fig. 3. The connections for a so-called “unit” generator-transformer arrangement are shown in Fig. 4; notice that the CT’s on the neutral side may be used in common by the differential-relaying equipments of the generator and the transformer.

For greatest sensitivity of differential relaying, the CT primary-current rating would have to be equal to the generator’s rated full-load current. However, in practice the CT primary-current rating is as much as about 25% higher than full load, so that if ammeters are connected to the CT’s their deflections will be less than full scale at rated load. It may be impossible to abide by this rule in Fig. 5; here, the primary-current rating of the CT’s may have to be considerably higher than the generator’s rated current, because of the higher system current that may flow through the CT’s at the breakers.

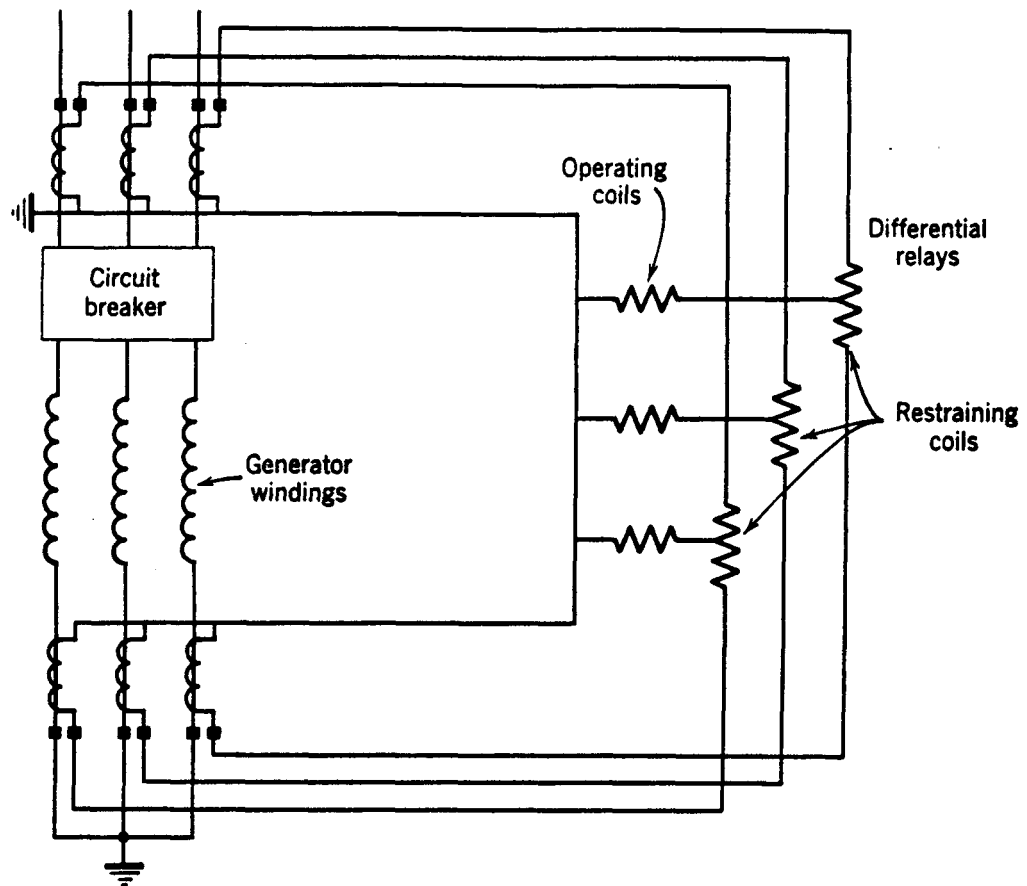

Fig. 1. Percentage-differential relaying for a wye-connected generator.

The way in which the generator neutral is grounded does not influence the choice of percentage-differential relaying equipment when both ends of all windings are brought out. But, if the neutral is not grounded, or if it is grounded through high enough impedance, the differential relays should be supplemented by sensitive ground-fault relaying, which will be described later. Such supplementary equipment is generally provided when the ground-fault current that the generator can supply to a single-phase-to-ground fault at its terminals is limited to less than about rated full-load current. Otherwise, the differential relays are sensitive enough to operate for ground faults anywhere from the

terminals down to somewhat less than about 20% of the winding away from the neutral, depending on the magnitude of fault current and load current, as shown in Fig. 6, which was obtained from calculations for certain assumed equipment. This is generally considered sensitive enough because, with less than 20% of rated voltage stressing the insulation, a ground fault is most unlikely; in the rare event that a fault did occur, it would simply have to spread until it involved enough of the winding to operate a relay. To make the percentage-differential relays much more sensitive than they are would make them likely to operate undesirably on transient CT errors during external disturbances.

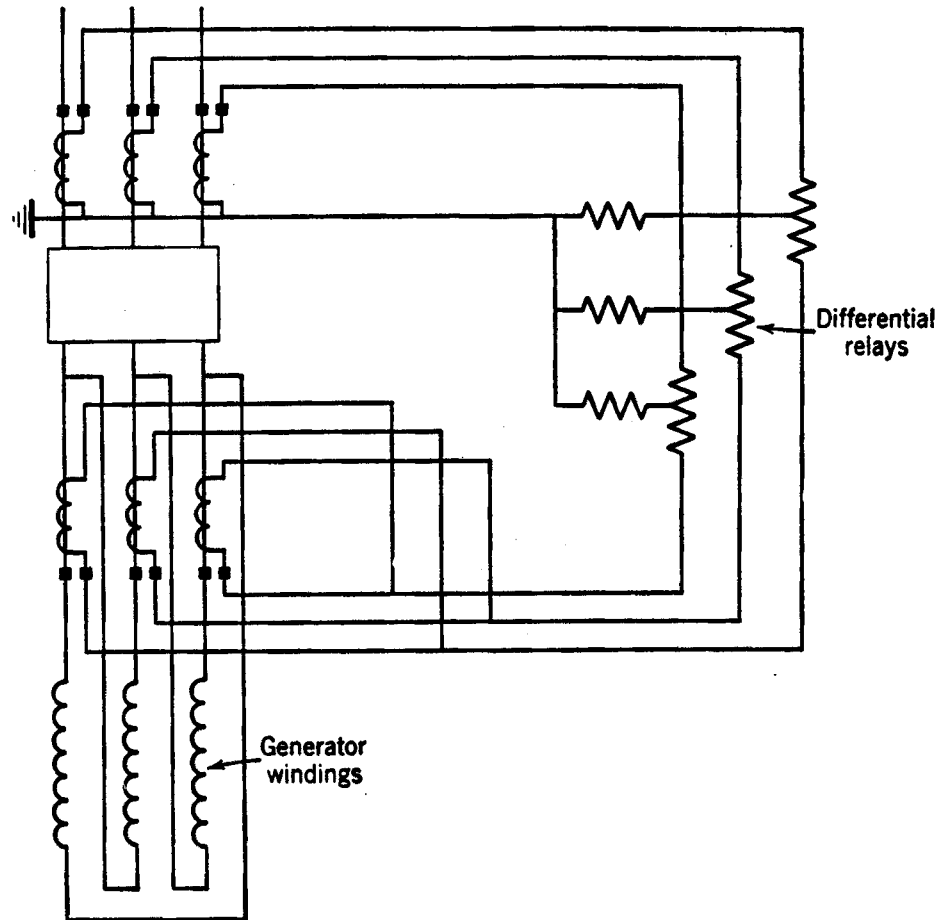

Fig. 2. Percentage-differential relaying for a delta-connected generator.

The foregoing raises the question of CT accuracy and loading. It is generally felt that CT's having an ASA accuracy classification of 10H200 or 10L200 are satisfactory if the burdens imposed on the CT's during external faults are not excessive. If variable-percentage relays (to be discussed later) are used, CT's of even lower accuracy classification may be permissible, or higher burdens may be applied. It is the difference in accuracy between the CT's (usually of the same type) at opposite ends of the windings that really counts. The difference between their ratio errors should not exceed about one-half of the percent slope of the differential relays for any external fault beyond the generator terminals. Such things as unequal CT secondary lead lengths, or the addition of other burdens in the leads on one side or the other, tend to make the CT's have different errors. A technique for calculating the steady-state errors of CT's in a differential circuit will be described for the circuit of Fig. 7, where a single-phase-to-ground external fault is assumed to have occurred

on the phase shown. The equivalent circuit of each CT is shown in order to illustrate the method of solution. The fact that $(I_{S1} - I_{S2})$ is flowing through the relay's operating coil in the direction shown is the result of assuming that CT₁ is more accurate than CT₂, or in other words that I_{S1} is greater than I_{S2} . We shall assume that I_{S1} and I_{S2} are in phase, and, by Kirchoff's laws, we can write the voltages for the circuit *a-b-c-d-a* as follows:

$$E_1 - I_{S1}(Z_{S1} + 2Z_{L1} + Z_R) - (I_{S1} - I_{S2})Z_0 = 0$$

or

$$(I_{S1} - I_{S2})Z_0 = E_1 - I_{S1}(Z_{S1} + 2Z_{L1} + Z_R) \quad (1)$$

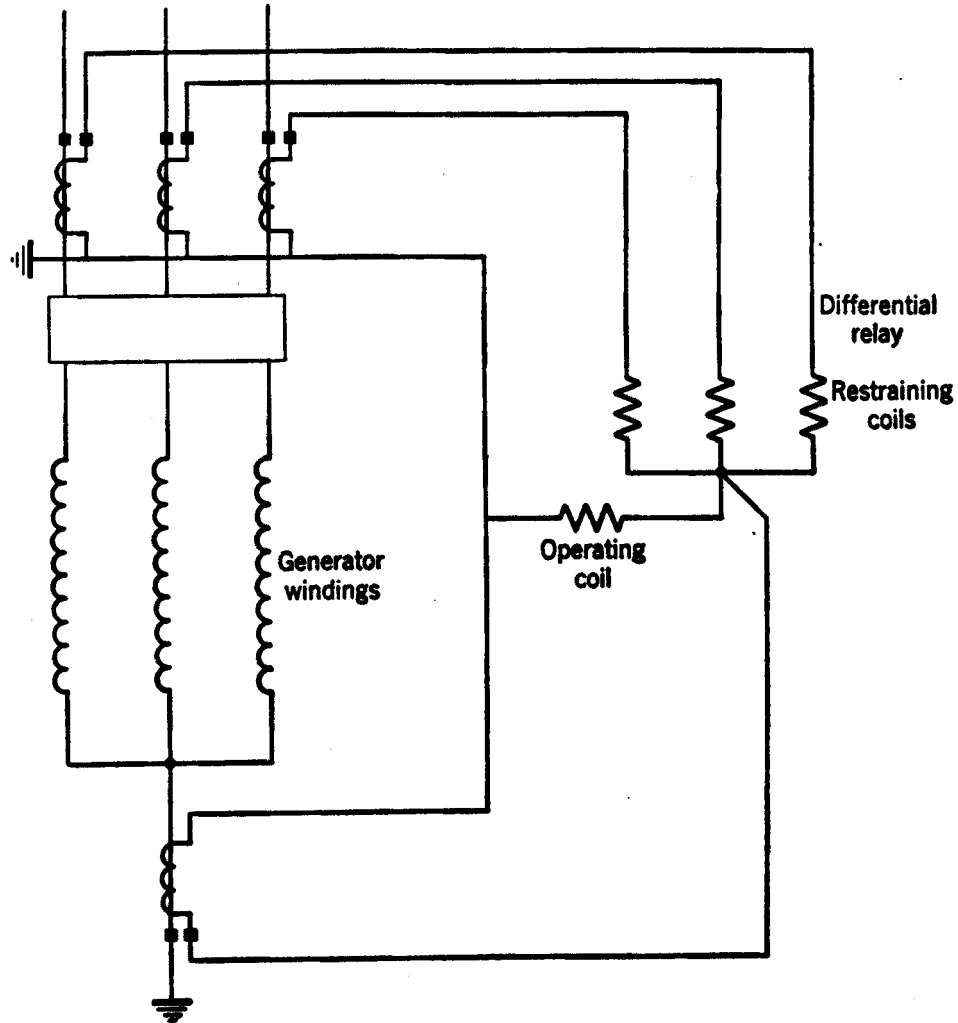

Fig. 3. Percentage-differential relaying for a wye-connected generator with only four leads brought out.

Similarly, for the circuit *e-f-d-c-e*, we can write:

$$E_2 - I_{S2}(Z_{S2} + 2Z_{L2} + Z_R) + (I_{S1} - I_{S2})Z_0 = 0$$

or

$$(I_{S1} - I_{S2})Z_0 = I_{S2}(Z_{S2} + 2Z_{L2} + Z_R) - E_2 \quad (2)$$

For each of the two equations 1 and 2, if we assume a value of the secondary-excitation voltage E , we can obtain a corresponding value of the secondary-excitation current I_e from the secondary-excitation curve. Having I_e we can get I_S from the relation $I_S = I/N - I_e$, where

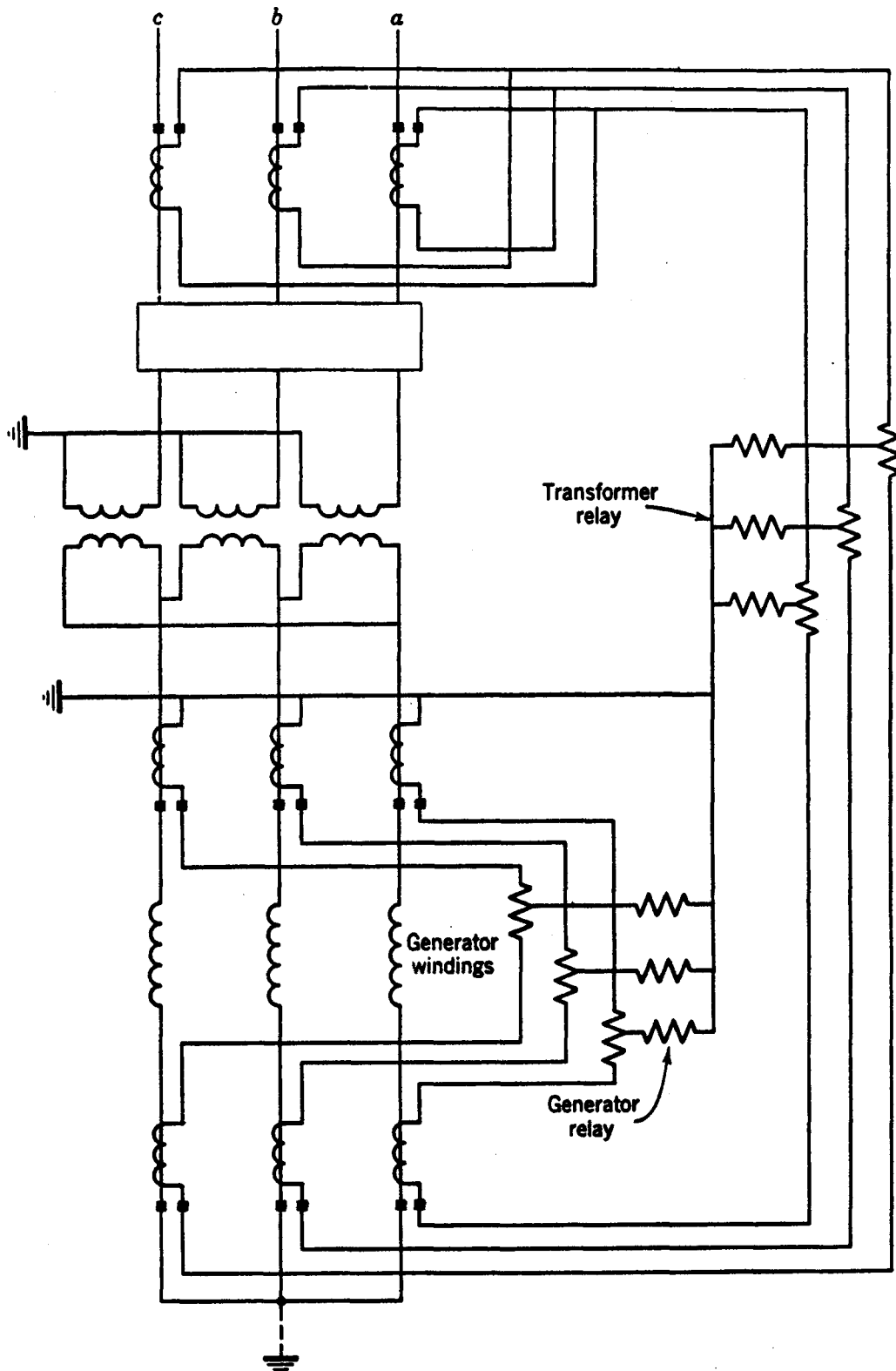

Fig. 4. Percentage-differential relaying for a unit generator and transformer.
 Note: phase sequence is *a-b-c*.

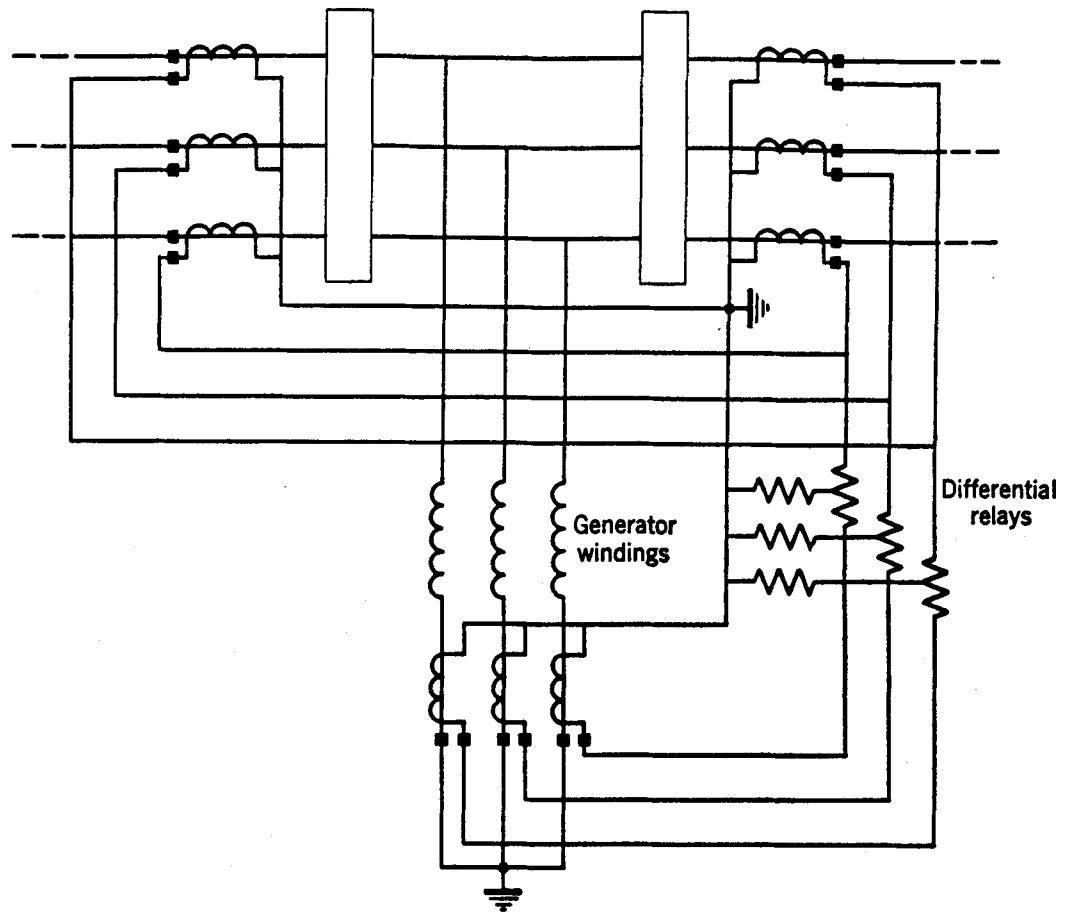

Fig. 5. Generator differential relaying with a double-breaker bus.

I is the initial rms magnitude of the fundamental component of primary current. This enables us to calculate the value of $(I_{S1} - I_{S2})$. Finally, the curves of I_{S1} and I_{S2} versus $(I_{S1} - I_{S2})$ for each of the two CT's is plotted on the same graph, as in Fig. 8. For only one value of the abscissa $(I_{S1} - I_{S2})$ will the difference between the two ordinates I_{S1} and I_{S2} be equal to that value of the abscissa and this is the point that gives us the solution to the problem. Once we know the values of I_{S1} and I_{S2} , we can quickly determine whether the differential relay will operate for the maximum external fault current.

From the example of Fig. 7, it will become evident that, for an external fault, if there is a tendency for one CT to be more accurate than the other, any current that flows through the operating coil of the relay imposes added burden on the more accurate CT and reduces the burden on the less accurate CT. Thus, there is a natural tendency in a current-differential circuit to resist CT unbalances, and this tendency is greater the more impedance there is in the relay's operating coil. This is not to say, however, that there may not sometimes be enough unbalance to cause incorrect differential-relay operation when the burden of leads or other devices in series with one CT is sufficiently greater than the burden in series with the other. If so, it becomes necessary to add compensating burden on one side to more nearly balance the burdens. If the CT's on one side are inherently considerably more accurate than on the other side, shunt burden, having saturation

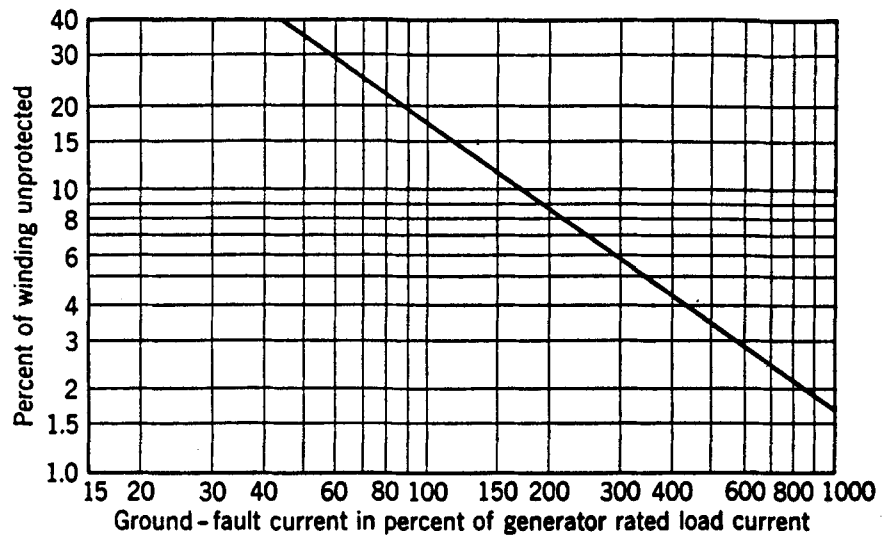

Fig. 6. Percent of winding unprotected for ground faults.

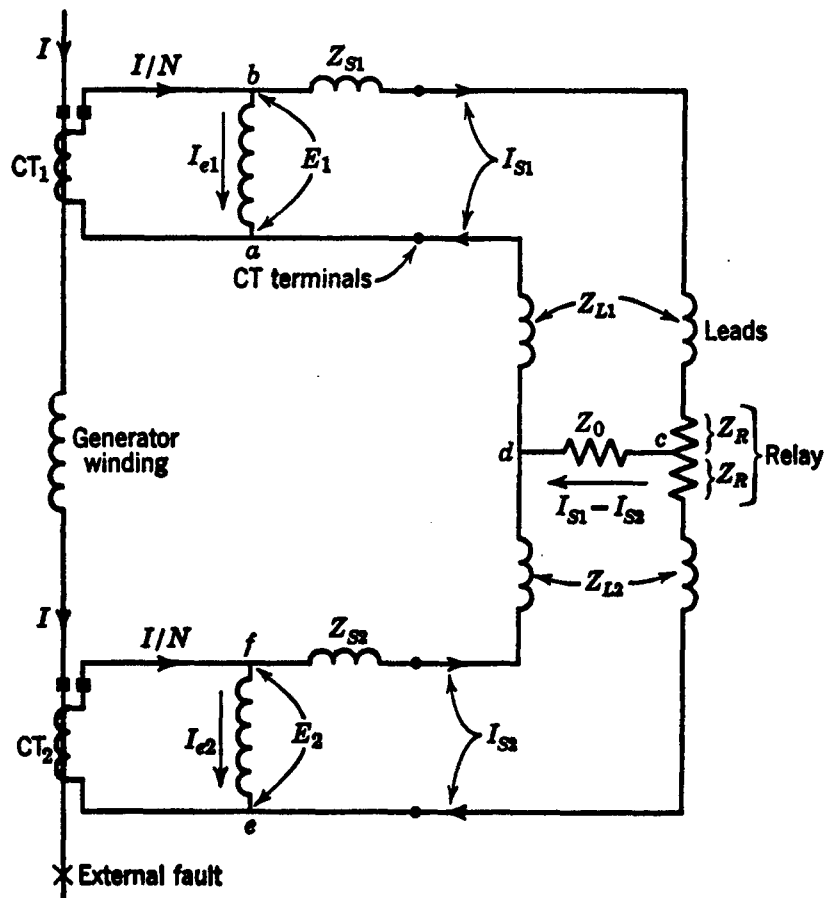

Fig. 7. Equivalent circuit for calculating CT errors in a generator differential circuit.

characteristics more or less like the secondary curve of the less accurate CT's, can be connected across the terminals of the more accurate CT's; this has the effect of making the two sets of CT's equally poor, but, at any rate, more nearly alike.

Another consequence of widely differing CT secondary-excitation characteristics may be “locking-in” for internal faults. In such a case, the inferior CT’s may be incapable of inducing sufficient rms voltage in their secondaries to keep the good CT’s from forcing current through the inferior CT’s secondaries in opposition to their induced voltage, thereby providing a shunt around the differential relay’s operating coil and preventing operation. Adding a shunt burden across the good CT’s, as was described in the foregoing paragraph, is a solution to this difficulty. The larger the impedance of the operating coil, the more likely locking-in is to happen. However, the circumstances that make it possible are rare.

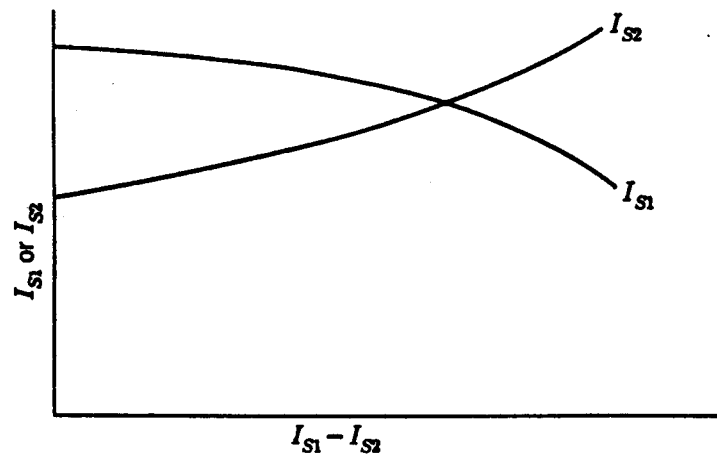

Fig. 8. Plot of the relations of the currents of Fig. 7 for various assumed values of E_1 and E_2 .

Chapter 7 described the possibility of harmfully high overvoltages in CT secondary circuits of generator-differential relays when the system is capable of supplying to a generator fault short-circuit current whose magnitude is many times the rating of the CT’s. In such cases, it is necessary to use overvoltage limiters, as treated in more detail in Chapter 7.

Whether to use high-speed relays or only the somewhat slower “instantaneous” relays is sometimes a point of contention. If system stability is involved, there may be no question but that high-speed relays must be used. Otherwise, the question is how much damage will be prevented by high-speed relays. The difference in the damage caused by the current supplied by the generator will probably be negligible in view of the continuing flow of fault current because of the slow decay of the field flux. But, if the system fault-current contribution is very large, considerable damage may be prevented by the use of high-speed relays and main circuit breaker. It is easy enough to compare the capabilities of doing damage in terms of I^2t , but the cost of repair is not necessarily directly proportional, and there are no good data in this respect. The savings to be made in the cost of slower-speed relays are insignificant compared to the cost of generators, and there cannot fail to be some benefits with high-speed relays. Except for “match and line-up” considerations, the slower-speed relays might well be eliminated.

Generally, the practice is to have the percentage-differential relays trip a hand-reset multi-contact auxiliary relay. This auxiliary relay simultaneously initiates the following: (1) trip main breaker, (2) trip field breaker, (3) trip neutral breaker if provided, (4) shut down the prime mover, (5) turn on CO_2 if provided, (6) operate an alarm and/or annunciator. The auxiliary relay may also initiate the transfer of station auxiliaries from the generator terminals to the reserve source, by tripping the auxiliary breaker. Whether to provide a

main breaker or only an exciter-field breaker is a point of contention. The tripping of a main-field breaker instead of only an exciter-field breaker will minimize the damage, but there is insufficient evidence to prove whether it is worth the additional expense where other important factors urge the omission of a main-field breaker. Consequently, the practice is divided.

THE VARIABLE-PERCENTAGE-DIFFERENTIAL RELAY

High-speed percentage-differential relays having variable ratio—or percent-slope characteristics are preferred. At low values of through current, the slope is about 5%, increasing to well over 50% at the high values of through current existing during external faults. This characteristic permits the application of sensitive high-speed relaying equipment using conventional current transformers, with no danger of undesired tripping because of transient inaccuracies in the CT's. To a certain extent, poorer CT's may be used—or higher burdens may be applied—than with fixed-percent-slope relays.

Two different operating principles are employed to obtain the variable characteristic. In both, saturation of the operating element is responsible for a certain amount of increase in the percent slope. In one equipment,¹³ saturation alone causes the slope to increase to about 20%; further increase is caused by the effect on the relay response of angular differences between the operating and restraining currents that occur owing to CT errors at high values of external short-circuit current. The net effect of both saturation and phase angle is to increase the slope to more than 50%.

The other equipment¹⁴ obtains a slope greater than 50% for large values of through current entirely by saturation of the operating element. A principle called “product restraint” is used to assure operation for internal short circuits. Product restraint provides restraint sufficient to overcome the effect of any CT errors for external short circuits; for internal short circuits when the system supplies very large currents to a fault, there is no restraint.

PROTECTION AGAINST TURN-TO-TURN-FAULTS IN STATOR WINDINGS

Differential relaying, as illustrated in Figs. 1-5, will not respond to faults between turns because there is no difference in the currents at the ends of a winding with shorted turns; a turn fault would have to burn through the major insulation to ground or to another phase before it could be detected. Some of the resulting damage would be prevented if protective-relaying equipment were provided to function for turn faults.

Turn-fault protection has been devised for multicircuit generators, and is used quite extensively, particularly in Canada.¹⁵ In the United States, the government-operated hydroelectric generating stations are the largest users. Because the coils of modern large steam-turbine generators usually have only one turn, they do not need turn-fault protection because turn faults cannot occur without involving ground.

Even though the benefits of turn-fault protection would apply equally well to single-circuit generators, equipment for providing this protection for such generators has not been used, although methods have been suggested;^{15,18} as will be seen later, the equipment used for multicircuit generators is not applicable to single-circuit generators.

To justify turn-fault protection, apart from what value it may have as duplicate protection, one must evaluate the savings in damage and outage time that it will provide. In a unit generator-transformer arrangement, considerable saving is possible where the generator operates ungrounded, or where high-resistance grounding or ground-fault-neutralizer grounding is used; if the ground-detecting equipment is not permitted to trip the generator breakers, a turn fault could burn much iron before the fault could spread to another phase and operate the differential relay. Even if the ground-detecting equipment is arranged to trip the generator breakers, it would probably be too slow to prevent considerable iron burning. (The foregoing leads to the further conclusion that if the generator has single-circuit windings with no turn-fault protection, the ground-fault detector should operate as quickly as possible to trip the generator breakers.)

For other than unit generator-transformer arrangements, and where the generator neutral is grounded through low impedance, the justification for turn-fault protection is not so apparent. The amount of iron burning that it would save would not be significant because conventional differential relaying will prevent excessive iron burning.¹⁹ Consequently, the principal saving would be in the cost of the coil-repair job, and it is questionable whether there would be a significant saving there.

The conventional method for providing turn-fault protection is called “split-phase” relaying, and is illustrated in Fig. 9. If there are more than two circuits per phase, they are divided into two equal groups of parallel circuits with a CT for each group. If there is an odd number of circuits, the number of circuits in each of the two groups will not be equal, and the CT’s must have different primary-current ratings so that under normal conditions their secondary currents will be equal. Split-phase relaying will operate for any type of short circuit in the generator windings, although it does not provide as good protection as differential relaying for some faults. The split-phase relays should operate the same hand-reset auxiliary tripping relay that is operated by the differential relays.

An inverse-time overcurrent relay is used for split-phase relaying rather than an instantaneous percentage-differential relay, in order to get the required sensitivity. For its use to be justified, split-phase relaying must respond when a single turn is short-circuited. Moreover, the relay equipment must not respond to any transient unbalance that there may be when external faults occur. If percentage restraint were used to prevent such undesired operation, the restraint caused by load current would make the relay too insensitive at full load. Consequently, time delay is relied on to prevent operation on transients.

Time delay tends somewhat to nullify the principal advantage of turn-fault protection, namely, that of tripping the generator breakers before the fault has had time to develop serious proportions. A supplementary instantaneous overcurrent unit is used together with the inverse-time unit, but the pickup of the instantaneous unit has to be so high to avoid undesired operation on transients that it will not respond unless several turns are short-circuited.

Faster and more sensitive protection can be provided if a double-primary, single-secondary CT, as shown in Fig. 10, is used rather than the two separate CT’s shown in Fig. 9.¹⁶ Such a double-primary CT eliminates all transient unbalances except those existing in the primary currents themselves. With such CT’s and with close attention to the generator design to minimize normal unbalance, very sensitive instantaneous protection is possible.¹⁷ Such practices have been limited to Canada.

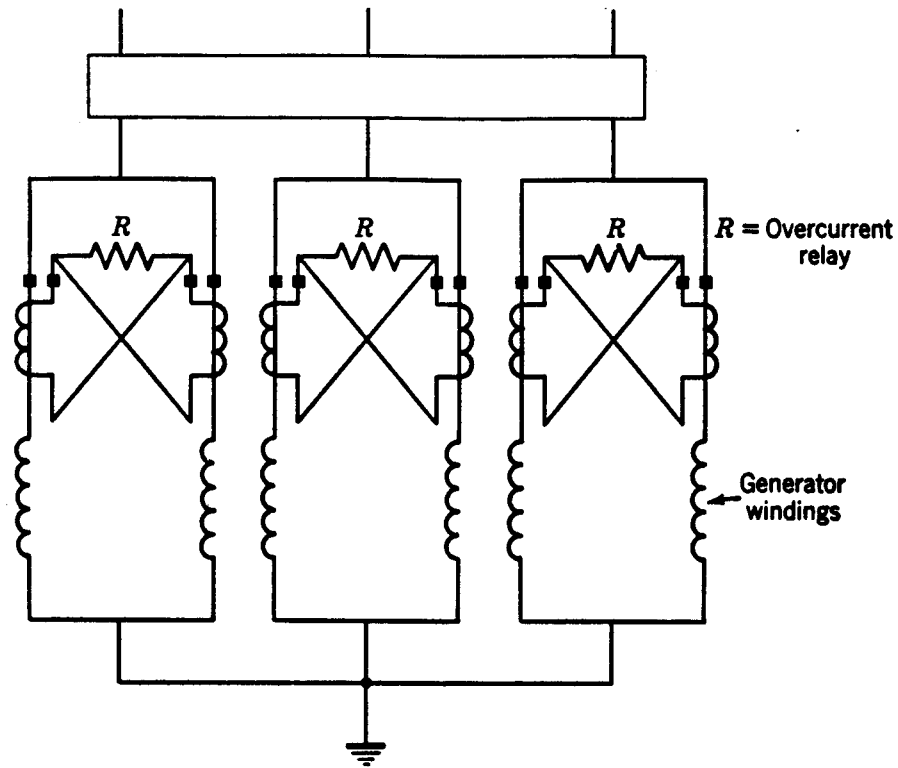

Fig. 9. Split-phase relaying for a multicircuit generator.

Split-phase relaying at its best could not completely replace over-all differential relaying which is required for protection of the generator circuit beyond the junctions of the paralleled windings. However, some people feel that if split-phase relaying is used with unit generator-transformer arrangements, it is not necessary to have separate generator-differential relaying if the transformer differential relaying includes the generator in its protective zone. This would be true if the split-phase relaying was instantaneous. The greater sensitivity of generator-differential relaying is not needed for faults beyond the generator windings. The principal advantage of retaining the generator-differential relaying, apart from the duplicate protection that it affords, is the value of its target indication in helping to locate a fault. However, if split-phase relaying is provided by inverse-time overcurrent relays, generator-differential relaying is recommended because of its higher speed for all except turn faults.

COMBINED SPLIT-PHASE AND OVER-ALL DIFFERENTIAL RELAYING

Figure 11 shows an arrangement that has been used to try to get the benefits of split-phase and over-all differential protection at a saving in current transformers and in relays. However, this arrangement is not as sensitive as the separate conventional split-phase and over-all differential equipments. Sensitivity for turn faults is sacrificed with a percentage-differential relay; with full-load secondary current flowing through the restraining coil, the pickup is considerably higher than with the conventional split-phase equipment, and the equipment will not operate if a single turn is shorted. With the main generator breaker open, the sensitivity for ground faults near the neutral end of the winding that does not have a current transformer may be considerably poorer than with the conventional over-

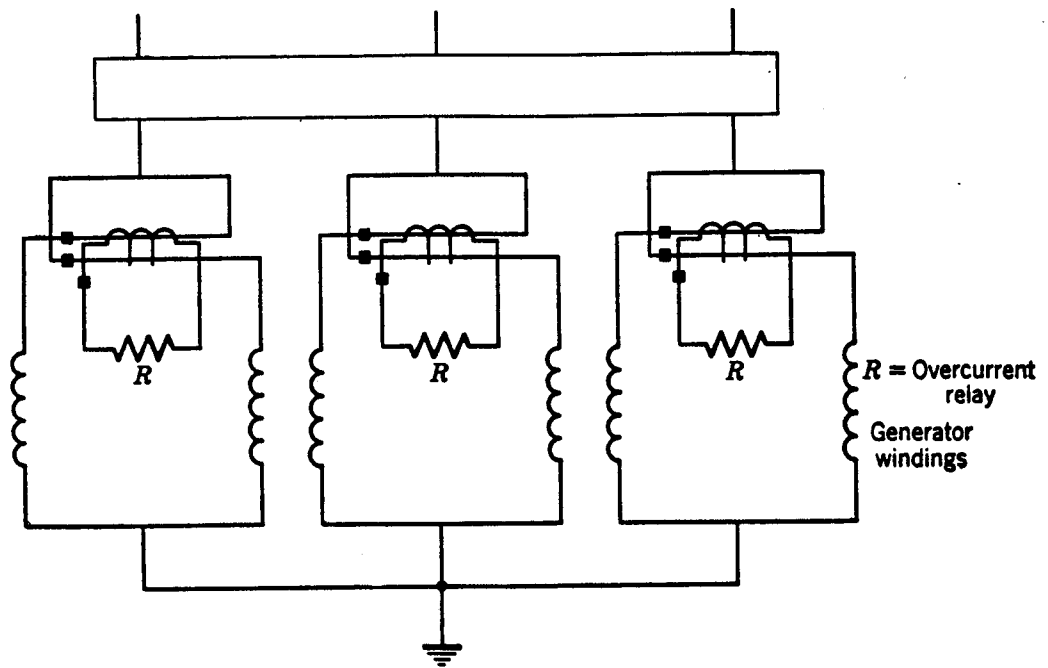

Fig. 10. Split-phase relaying using double-primary current transformers.

all differential; the current flowing in the winding having the CT is much smaller than one-half of the current flowing in the neutral lead where the over-all differential CT would be. For this reason, the modification shown in Fig. 12 is sometimes used.

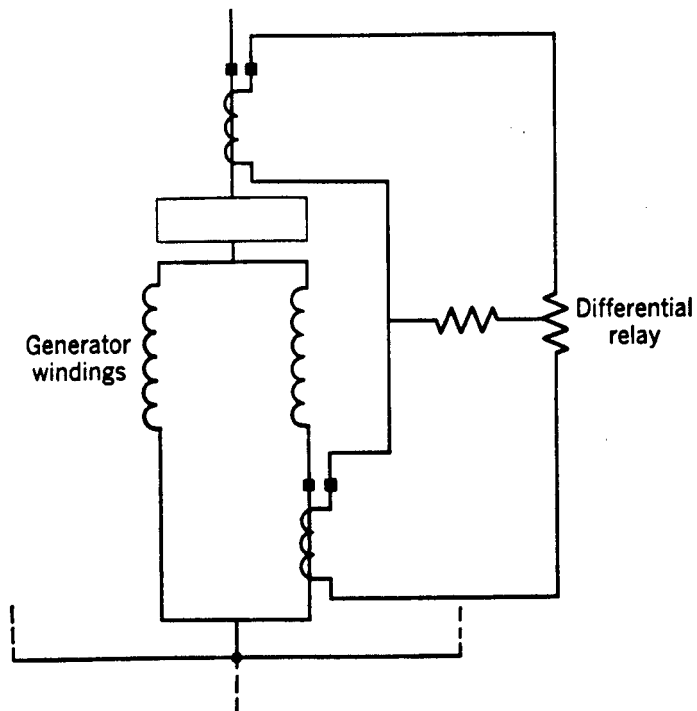

Fig. 11. Combined split-phase and differential relaying (shown for one phase only).

SENSITIVE STATOR GROUND-FAULT RELAYING

The protection of unit generator-transformer arrangements is described under the next heading. Here, we are concerned with other than unit arrangements, where the generator's neutral is grounded through such high impedance that conventional percentage-differential relaying equipment is not sensitive enough. The problem here is to get the required sensitivity and at the same time to avoid the possibility of undesired

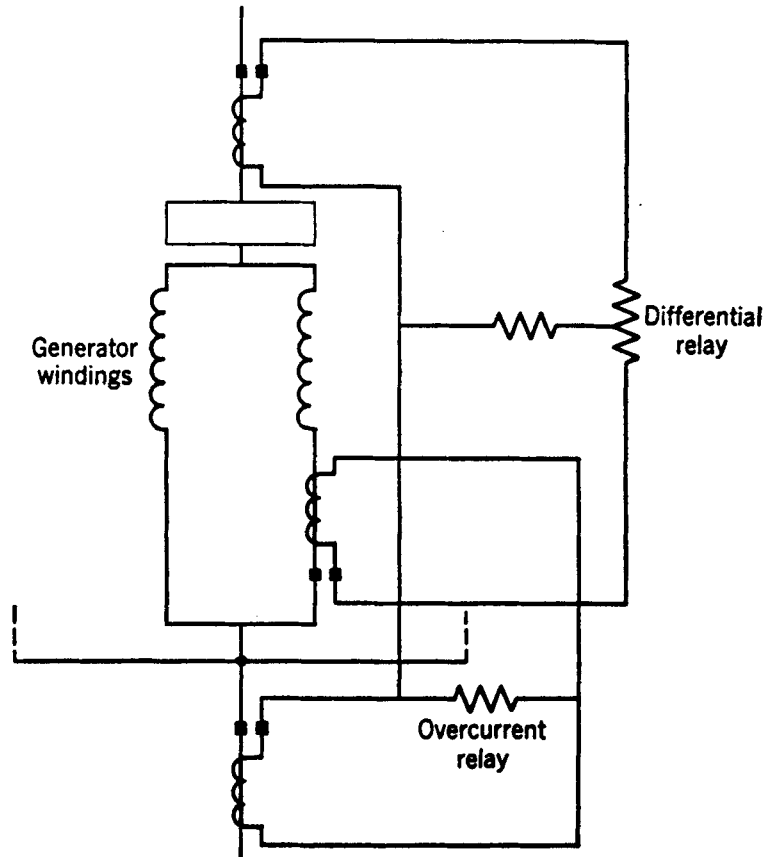

Fig. 12. Modification of Fig. 11 for greater sensitivity.

operation because of CT errors with large external-fault currents. Figure 13 shows a solution to the problem: a current-current directional relay is shown whose operating coil is in the neutral of the differential-relay circuit and whose polarizing coil is energized from a CT in the generator neutral. A polarized relay provides greater sensitivity without excessive operating-coil burden; the polarizing CT may have a low enough ratio so that the polarizing coil will be “soaked” for the short duration of the fault. Supplementary equipment may sometimes be required to prevent undesired operation because of CT errors during external two-phase-to-ground faults.

STATOR GROUND-FAULT PROTECTION OF UNIT GENERATORS.

Figure 14 shows the preferred way¹⁹ to provide ground-fault protection for a generator that is operated as a unit with its power transformer. The generator neutral is grounded through the high-voltage winding of a distribution transformer. A resistor and an overvoltage relay are connected across the low-voltage winding

It has been found by test that, to avoid the possibility of harmfully high transient overvoltages because of ferroresonance, the resistance of the resistor should be no higher, approximately, than:

$$R = \frac{X_C}{3N^2} \text{ ohms}$$

where X_C is the total phase-to-ground-capacity reactance *per phase* of the generator stator windings, the surge protective capacitors or lightning arresters, if used, the leads to the main and station-service power transformers, and the power-transformer windings on the generator side; and N is the open-circuit voltage ratio (or turns ratio) of the high-voltage to the low-voltage windings of the distribution transformer.²⁰

The value of R may be less than that given by the foregoing equation. The value of resistance given by the equation will limit the maximum instantaneous value of the transient voltage to ground to about 260% of normal line-to-ground crest value. Further reduction in resistance will not appreciably reduce the magnitude of the transient voltage. The lower the value of R , the more damage will be done by a ground fault, particularly if the relay is not connected to trip the generator breakers. The relaying sensitivity will decrease as R is decreased, because, as can be seen in Fig. 15, more of the available voltage will be consumed in the positive and negative-phase-sequence impedances and less in the zero-phase-sequence impedance which determines the magnitude of the relay voltage. This decrease in sensitivity is considered by some people to be an advantage because the relay will be less likely to operate for faults on the low-voltage side of the generator potential transformers, as discussed later. In fact, it has been suggested²¹ that for this reason, and also to simplify the calculations by making it unnecessary to determine X_C a resistor be chosen that will limit the fault current to approximately 15 amperes, neglecting the effect of X_C . In other words,

$$R = \frac{10^3 V_G}{15\sqrt{3} N^2} \text{ ohms}$$

where V_G is the phase-to-phase-voltage rating of the generator in kilovolts.

It has been suggested that, to avoid large magnetizing-current flow to the distribution transformer when a ground fault occurs, the high-voltage rating of the distribution transformer should be at least 1.5 times the phase-to-neutral-voltage rating of the generator.²⁰ Its insulation class must fulfill the standard requirements for neutral grounding devices.²² The low-voltage rating may be 120, 240, or 480 volts, depending on the available or desired voltage rating of the protective relay.

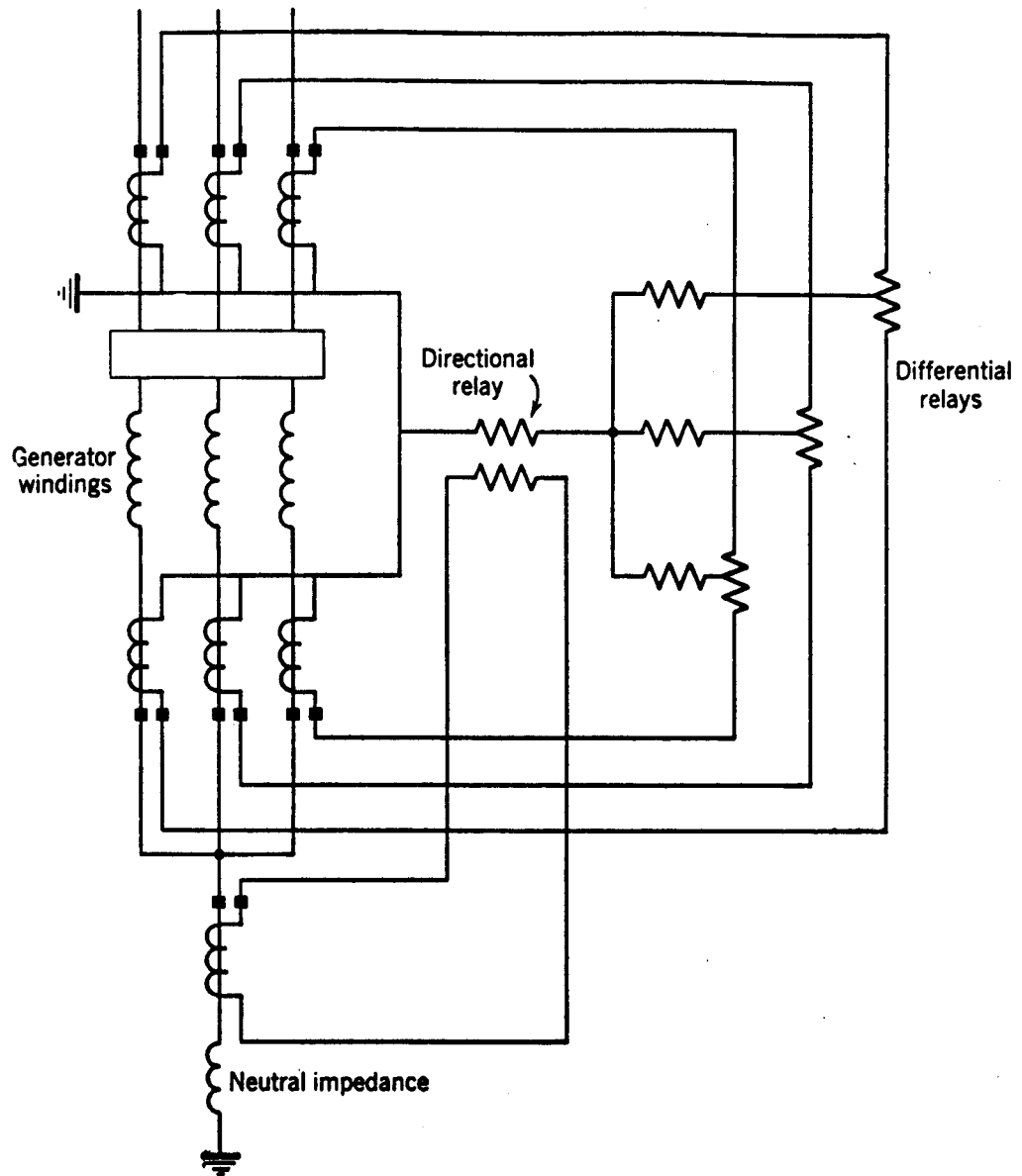

Fig. 13. Sensitive stator ground-fault relaying for generators.

The kva rating to choose for the distribution transformer and for the resistor will depend on whether the user intends to let the overvoltage relay trip the generator main and field breakers or merely sound an alarm. If the relay will merely sound an alarm, the transformer should be continuously rated for at least:

$$kva = \frac{10^3 V_G V_T}{\sqrt{3} N^2 R}$$

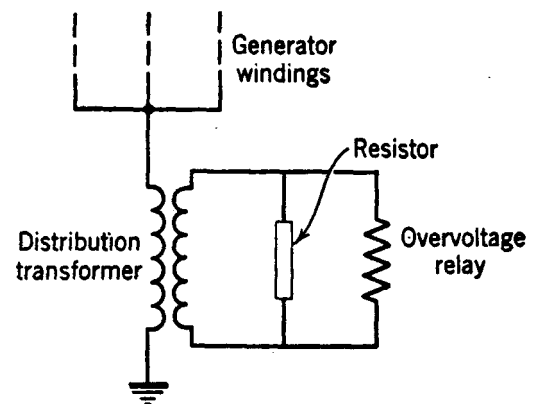

Fig. 14. Stator ground-fault protection of unit generators.

where V_T is the high-voltage rating of the distribution transformer in kilovolts. Similarly, the continuous rating of the resistor should be at least:

$$kw = \frac{10^3 V_G^2}{3N^2 R}$$

If the relay is arranged to trip the generator breakers, short-time transformer and resistor ratings²³ may be used. For example, a 1-minute-rating transformer would have only 21% of the continuous kva rating, and a 10-minute rating would have 40%. However, the lower the transformer rating, the more inductive reactance the transformer will introduce in series with the grounding resistance; for this reason, the 1-minute rating is the lowest considered desirable. The resistor may have either a 10-second or a 1-minute rating, but the 1-minute rating is generally preferred because it is more conservative and not much more expensive. In fact, continuous-rated resistors may even be economical enough.

It is preferred to have the relay trip the generator main and field breakers. Even though the fault current is very low, some welding of the stator laminations may occur if the generator is permitted to continue operating with a ground fault in its winding.²⁴ Also, in the presence of the fault, the voltage to ground of other parts of the stator windings will rise to $\sqrt{3}$ times normal; should this cause another ground fault to develop, a phase-to-phase fault might result, and additional damage would be done that would have been avoided had the generator breakers been tripped when the first fault occurred. Furthermore, if split-phase protection is not provided and if the ground relay is not permitted to trip, the generator could develop a turn-to-turn fault and there might be considerable iron burning before the fault could spread to another phase and cause the differential relays to operate. In spite of the foregoing, many power companies are willing to risk the possibility of additional damage until they can conveniently remove the faulty generator from service.

A number of power companies simply connect a potential transformer between the generator neutral and ground without any loading resistor. They have operated this way for years, apparently without any difficulty.¹⁹ An overvoltage relay is used as with the distribution-transformer arrangement. The maximum current that can flow in a ground fault is 71% of that with the distribution-transformer-and-resistor combination if the maximum allowable value of R is used, which is not a significant difference. In either case, the arc energy is sufficient to cause damage if immediate tripping is not done.²⁵ The potential transformer is considerably smaller and cheaper than the distribution-transformer-and-resistor combination, although either one is relatively inexpensive compared with the equipment protected. The principal disadvantage is that the user cannot be certain whether harmfully high transient overvoltages will occur. The only evidence we have is that such overvoltages can occur—at least under laboratory-controlled circumstances. Therefore, until positive evidence to the contrary is presented, the distribution-transformer-and-resistor combination seems to be safer.

If one prefers to let a generator operate with a ground fault in its stator winding, a ground-fault neutralizer will limit the fault current to the smallest value of any of the arrangements, and at the same time will hold the transient voltage to a lower level.²⁵ However, it is necessary to be sure that surge-protective capacitors, if used, cannot cause harmfully high overvoltages should a defect cause the capacitances to ground to become unbalanced.²⁶

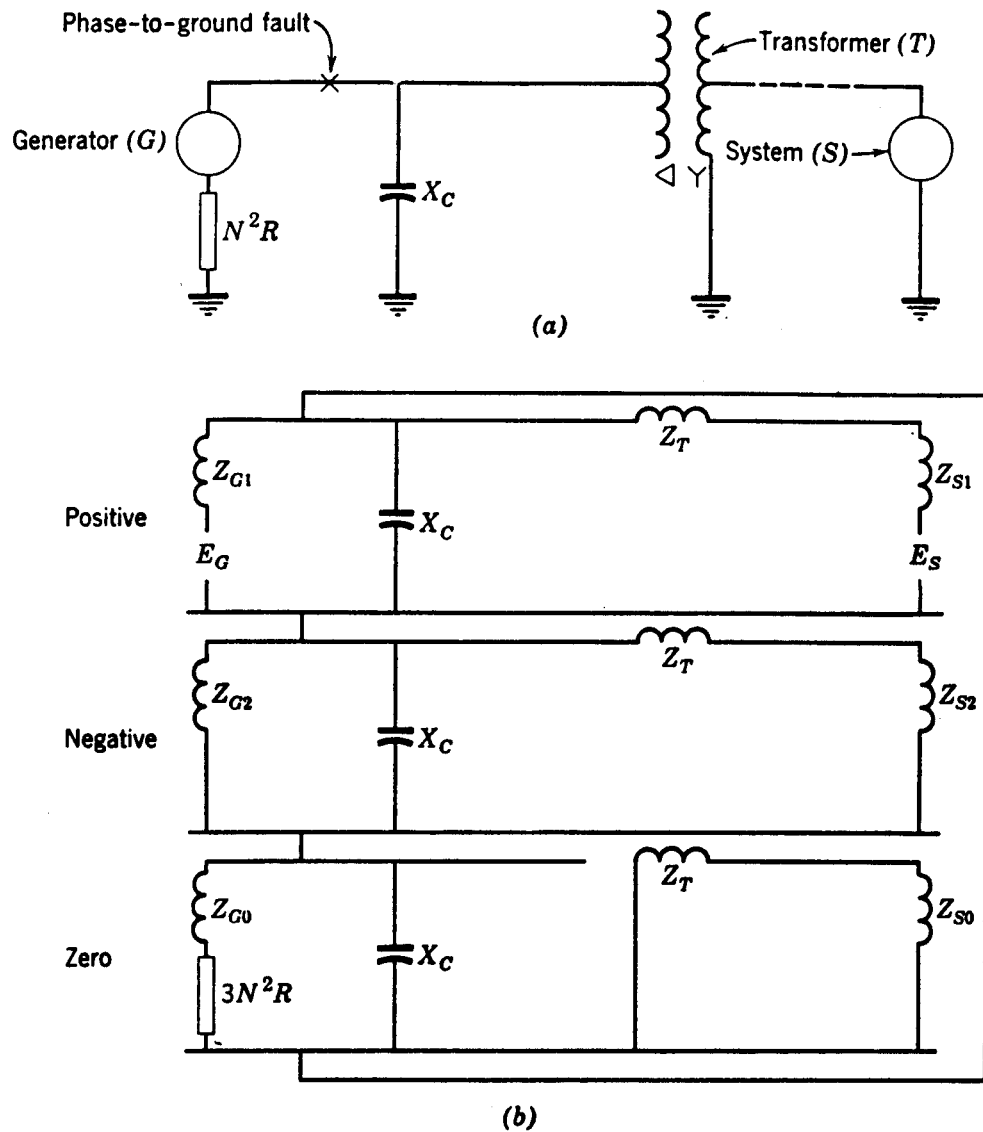

Fig. 15. (a) One-line diagram of a system with a unit generator and a phase-to ground fault. (b) Phase-sequence diagram for (a).

Reference 27 describes a modification of the foregoing methods whereby voltage is introduced between the generator neutral and ground for the purpose of obtaining greater sensitivity. Little, if any, application of this principle exists presently in the United States.

The same overvoltage-relay characteristics are required for any of the foregoing generator-neutral-grounding methods. The relay must be sensitive to fundamental-frequency voltages and insensitive to the third-harmonic and multiples of third-harmonic voltages. The relay may require adjustable time delay so as to be selective with other relays for ground faults on the high-voltage side of the main power transformer for which there may be a tendency to operate owing to capacitance coupling between the power-transformer windings, particularly if the high-voltage winding of the power transformer does not have its neutral solidly grounded;^{19,20,25} the ground-fault-neutralizer-grounding arrangement has the greatest operating tendency under such circumstances, and the distribution-transformer arrangement has the least. Time delay is desirable also to provide as good

selectivity as possible with potential-transformer fuses for faults on the secondary side of potential transformers connected wye-wye. If the relaying equipment is used only to sound an alarm, a combination of relays may be required to get both good sensitivity and a high continuous-voltage rating.

If grounded-neutral wye-wye potential transformers are connected to the generator leads, it may be impossible to get complete selectivity between the relay and the PT (potential-transformer) fuses for certain ground faults on the low-voltage side of the PT's, depending on the fuse ratings and on the relay sensitivity.²¹ In other words, the relay may sometimes operate when there is not enough fault current to blow a fuse. Such lack of coordination might be considered an advantage; the relay will protect the PT's from thermal damage for which the fuses could not protect. To make the relay insensitive enough so that it would not operate for low-voltage ground faults would sacrifice too much sensitivity for generator faults. Of course, if the relay has time delay, it will not operate for a momentary short circuit such as might be caused inadvertently during testing. If the relay is used only to sound an alarm, some selectivity may be sacrificed in the interests of sensitivity; the relay will not operate frequently enough to be a nuisance.

SHORT CIRCUIT PROTECTION OF STATOR WINDINGS BY OVERCURRENT RELAYS

If current transformers are not connected in the neutral ends of wye-connected generator windings, or if only the outgoing leads are brought out, protective devices can be actuated, as in Fig. 16, only by the short-circuit current supplied by the system. Such protection is when the main circuit breaker is open, or when it is closed if the system has no other generating source, and the following discussion assumes that short-circuit current is available from the system. If the generator's neutral is not grounded, sensitive and fast ground overcurrent protection can be provided; but, if the neutral is grounded, directional overcurrent relaying should be used for the greatest sensitivity and speed. In either event, directional overcurrent relays should be used for phase-fault protection for the greatest sensitivity and speed.

If non-directional voltage-restrained or -controlled overcurrent relays are used for external-fault back-up protection, they could also serve to protect against generator phase faults.

None of the foregoing forms of relaying will provide nearly as good protection as percentage-differential relaying equipment, and they should not be used except when the cost of bringing out the generator leads and installing current transformers and differential relays cannot be justified.

PROTECTION AGAINST STATOR OPEN CIRCUITS

An open circuit or a high-resistance joint in a stator winding is very difficult to detect before it has caused considerable damage. Split-phase relaying may provide such protection, but only the most sensitive equipment will detect the trouble in its early stages.¹⁷ Negative-phase-sequence-relaying equipment for protection against unbalanced phase currents contains a sensitive alarm unit that will alert an operator to the abnormal condition.

It is not the practice to provide protective-relaying equipment purposely for open circuits. Open circuits are most unlikely in well-constructed machines.

STATOR-OVERHEATING PROTECTION

General stator overheating is caused by overloading or by failure of the cooling system, and it can be detected quite easily. Overheating because of short-circuited laminations is very localized, and it is just a matter of chance whether it can be detected before serious damage is done.

The practice is to embed resistance temperature-detector coils or thermocouples in the slots with the stator windings of generators larger than about 500 to 1500 kva. Enough of these detectors are located at different places in the windings so that an indication can be obtained of the temperature conditions throughout the stator.²⁸ Several of the detectors that give the highest temperature indication are selected for use with a temperature indicator or recorder, usually having alarm contacts; or the detector giving the highest indication may be arranged to operate a temperature relay to sound an alarm.

Supplementary temperature devices may monitor the cooling system; such equipment would give the earliest alarm in the event of cooling-system failure, but it is generally felt that the stator temperature detectors and alarm devices are sufficient.

Figure 17 shows one form of detector-operated relaying equipment using a Wheatstone-bridge circuit and a directional relay. In another form of equipment, the stator current is used to energize the bridge.

“Replica”-type temperature relays may be used with small generators that do not have temperature detectors. Such a relay is energized either directly by the current flowing in one of the stator windings of the machine or indirectly from current transformers in the stator circuit. The relay is arranged with heating and heat-storage elements so as to heat up and cool down as nearly as possible at the same rate as the machine in response to the same variations in the current. A thermostatic element closes contacts at a selected temperature. It will be evident that such a relay will not operate for failure of the cooling system.

The temperature-detector-operated devices are preferred because they respond more nearly to the actual temperature of the stator. The fact that the actual stator copper temperature is higher than the temperature at the detector²⁹ should be taken into account in the adjustment of the temperature relay. This difference in temperature may be 25°C or more in hydrogen-cooled machines, being greater at the higher hydrogen pressures. Thus, if the permissible copper temperature is assumed to remain constant with higher loading at higher hydrogen pressure, the temperature-relay setting must be lower.

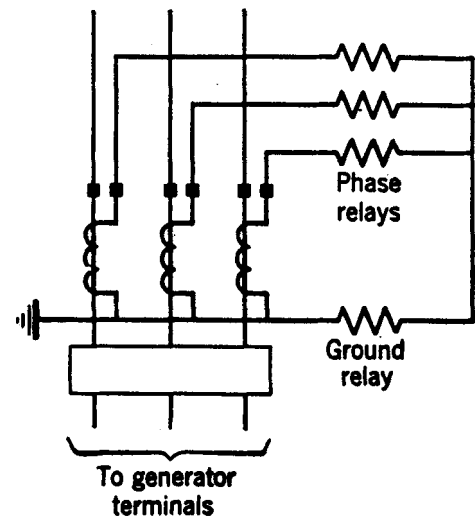

Fig. 16. Generator stator overcurrent relay.

In unattended stations, temperature relays are arranged to reduce the load or shut down the unit if it overheats, but in an attended station the relay, if used, merely sounds an alarm. It should not be inferred from the foregoing that a generator may be loaded on the basis of temperature, because such practice is not recommended.

OVERVOLTAGE PROTECTION

Overvoltage protection is recommended for all hydroelectric or gas-turbine generators that are subject to overspeed and consequent overvoltage on loss of load. It is not generally required with steamturbine generators.

This protection is often provided by the voltage-regulating equipment. If it is not, it should be provided by an a-c overvoltage relay. This relay should have a time-delay unit with pickup at about 110% of rated voltage, and an instantaneous unit with pickup at about 130% to 150% of rated voltage. Both relay units should be compensated against the effect of varying frequency. The relay should be energized from a potential transformer other than the one used for the automatic voltage regulator. Its operation should, preferably, first cause additional resistance to be inserted in the generator or exciter field circuit. Then, if overvoltage persists, the main generator breaker and the generator or exciter field breaker should be tripped.

LOSS-OF-SYNCHRONISM PROTECTION

It is not the usual practice to provide loss-of-synchronism protection at a prime-mover-driven generator. One generator is not likely to lose synchronism with other generators in the same station unless it loses excitation, for which protection is usually provided. Whether a station has one generator or more, if this station loses synchronism with another station, the necessary tripping to separate the generators that are out of step is usually done in the interconnecting transmission system between them; this is discussed at greater length in Chapter 14. However, loss-of-synchronism relaying equipment is available for use at a generating station if desired.

All induction-synchronous frequency converters for interconnecting two systems should have loss-of-synchronism protection on the synchronous-machine side. With synchronous-synchronous sets, such protection may be required on both sides. Operation of the relay should trip the main breaker on the side where the relay is located. The operating characteristics of a relay that can be used for this purpose are shown in Chapter 14.

FIELD GROUND-FAULT PROTECTION

Because field circuits are operated ungrounded, a single ground fault will not cause any damage or affect the operation of a generator in any way. However, the existence of a single ground fault increases the stress to ground at other points in the field winding when voltages are induced in the field by stator transients.³⁰ Thus, the probability of a second ground occurring is increased. Should a second ground occur, part of the field winding will be by-passed, and the current through the remaining portion may be increased.

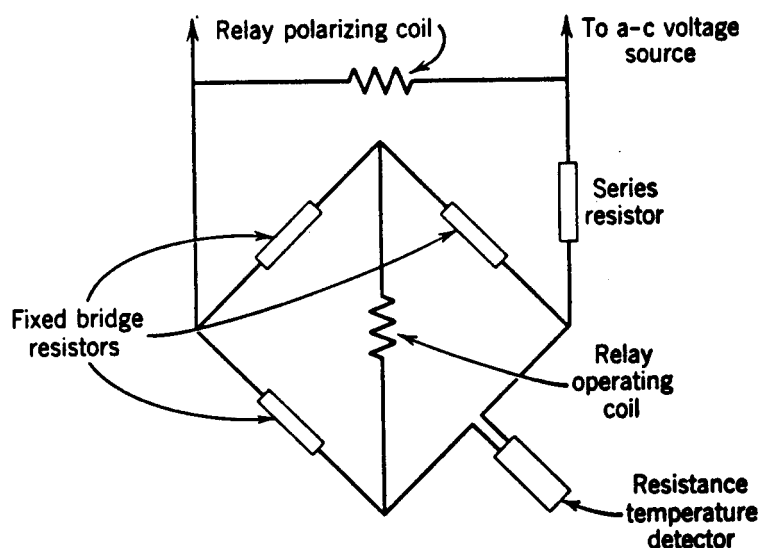

Fig. 17. Stator overheating relaying with resistance temperature detectors.

By-passing part of the field winding will unbalance the air-gap fluxes, and this will unbalance the magnetic forces on opposite sides of the rotor. Depending on what portion of the field is by-passed, this unbalance of forces may be large enough to spring the rotor shaft, and make it eccentric. A calculation of the possible unbalance force for a particular generator gave 40,000 pounds.³¹ Cases are on record where the resulting vibration has broken bearing pedestals, allowing the rotor to grind against the stator; such failures caused extensive damage that was costly to repair and that kept the machines out of service for a long time.³¹

The second ground fault may not by-pass enough of the field winding to cause a bad magnetic unbalance, but arcing at the fault may heat the rotor locally and slowly distort it, thereby causing eccentricity and its accompanying vibration to develop slowly in from 30 minutes to 2 hours.

The safest practice is to use protective-relaying equipment to trip the generator's main and field breakers immediately when the first ground fault occurs, and this practice should certainly be followed in all unattended stations. However, many would rather risk the chance of a second ground fault and its possible consequences in an attended station, in order to keep the machine in service until it is more convenient to shut it down;⁹ this group would use protective-relaying—or other—equipment, if any—merely to actuate an alarm or an indication when the first ground fault has occurred.

If a generator is to be permitted to operate with a single ground fault in its field, there should at least be provided automatic equipment for immediately tripping the main and field breakers at an abnormal amplitude of vibration, but at no higher amplitude than necessary to avoid undesired operation on synchronizing or short-circuit transients. Such equipment would minimize the duration of severe vibration should the second ground fault occur at a critical location; obviously, the vibration cannot be stopped instantly because it takes time for the field flux to decay, but this is the best that can be done under the circumstances; the authors of Reference 31 calculated the effect of such prolonged vibration decreasing in amplitude and felt that there was no hazard. However, damage has been known to occur immediately when the second ground occurred and before anything could be done to prevent it. Vibration-detecting equipment should be in service

continuously and not be put in service manually after the first ground fault has occurred, because the two ground faults may occur together or in quick succession. In addition, at least an alarm would be desirable, and preferably time-delay automatic tripping of the main and field breakers, at a still lower amplitude of vibration. This lower-set time-delay equipment would minimize the amplitude of vibration caused by rotor distortion because of localized heating. If this lower-set equipment were provided, the high-set vibration equipment could be permitted to shut down the prime mover as well as to trip the main and field breakers. The low-set equipment should preferably not shut down the prime mover; if the vibration is being caused by rotor eccentricity because of local heating, the amplitude might increase to a dangerous amount as the rotor speed decreases, because many generators have a critical speed below normal at which vibration may be materially worse than at normal speed; instead, it would be preferable to trip the main and field breakers and keep the rotor turning at normal speed for 30 minutes to an hour to cool the rotor and let it straighten itself out.

In spite of the known hazard of extensive damage and a long-time outage, many generators are in service with no automatic protection or even alarm for field grounds, and the majority of the rest have ground-indication equipment only. This can only mean that, during the time that a generator is being operated with one ground in its field, the probability is remote of a second ground occurring and at such a location as to cause immediate damage before an operator can act to correct the condition. The possibility exists, nevertheless, and one should avoid such operation if at all possible.

The preferred type of protective-relaying equipment is shown in Fig. 18. Either a-c or d-c voltage may be impressed between the field circuit and ground through an overvoltage relay. A ground anywhere in the field circuit will pick up the relay. If direct current is used, the overvoltage relay can be more sensitive than if alternating current is used; with alternating current, the relay must not pick up on the current that flows normally through the capacitance to ground, and care must be taken to avoid resonance between this capacitance and the relay inductance.

It may be necessary to provide a brush on the rotor shaft that will effectively ground the rotor, especially when a-c voltage is applied.³² One should not rely on the path to ground through the bearing-oil film for two reasons: (1) the resistance of this path may be high enough so that the relay would not operate if the field became grounded, and (2) even a very small magnitude of current flowing continually through the bearing may pit the surface and destroy the bearing.³³ A brush will probably be required with a steam turbine having steam seals. The brush should be located where it will not by-pass the bearing-pedestal insulation that is provided to prevent the flow of shaft currents. One should consult the turbine manufacturer before deciding that such a brush is not required.

PROTECTION AGAINST ROTOR OVERHEATING BECAUSE OF UNBALANCED THREE-PHASE STATOR CURRENTS

Unbalanced three-phase stator currents cause double-system-frequency currents to be induced in the rotor iron. These currents will quickly cause rotor overheating and serious damage if the generator is permitted to continue operating with such an unbalance.^{34,35,36} Unbalanced currents may also cause severe vibration, but the overheating problem is more acute.

Standards have been established for the operation of generators with unbalanced stator currents.³⁷ The length of time (T) that a generator may be expected to operate with unbalanced stator currents without danger of being damaged can be expressed in the form:

$$\int_0^T i_2^2 dt = K$$

where i_2 is the instantaneous negative-phase-sequence component of the stator current as a function of time; i_2 is expressed in per unit based on the generator rating, and K is a constant. K is 30 for steam-turbine generators, synchronous condensers, and frequency-charger sets; K is 40 for hydraulic-turbine generators, and engine-driven generators. If the integrated value is between that given for K and twice this value, the generator “may suffer

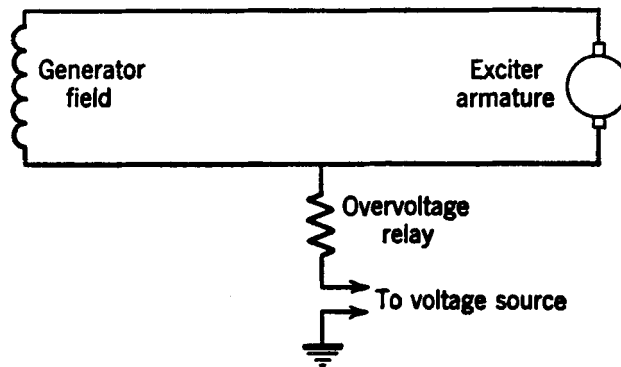

Fig. 18. Generator field ground-fault relaying.

varying degrees of damage, and an early inspection of the rotor surface is recommended.”³⁷ If the integrated value is greater than twice that given for K , “serious damage should be expected.”

If we let I_2^2 be the average value of i_2^2 over the time interval T , we can express the foregoing relation in the handy form $I_2^2 T = 30$ or $I_2^2 T = 40$, depending on the type of generator. If T is longer than 30 seconds, I_2 may be larger than the foregoing relation would permit, but no general figures can be given that would apply to any machine.^{34,36,38}

It has been shown that current-balance relaying equipment operating from the phase currents will operate too quickly for small unbalances and too slowly for large unbalances.³⁹

The recommended type of relaying equipment is an inverse-time overcurrent relay operating from the output of a negative-phase-sequence-current filter that is energized from the generator CT’s as in Fig. 19.^{38,39} The relay’s time-current characteristics are of the form $I^2 T = K$, so that, with the pickup and time-delay adjustments that are provided, the relay characteristic can be chosen to match closely any machine characteristic. The relay should be connected to trip the generator’s main breaker. Some forms of the relay also include a very sensitive unit to control an alarm for small unbalances.

Extensive studies have shown that, in the majority of cases, the negative-phase-sequence-current relay will properly coordinate with other system-relaying equipment.^{40,41} Improper coordination is said to be possible where load is supplied at generator voltage and where

there are five or more generators in the system. For a unit generator-transformer arrangement, proper coordination is assured.

The fact that the system-relaying equipment will generally operate first might lead to the conclusion that, with modern protective equipment, protection against unbalanced three-phase currents during short circuits is not required.^{36,42} This conclusion might be reached also from the fact that there has been no great demand for improvement of the existing forms of protection. The sensitive alarm unit would be helpful to alert an operator in the event of an open circuit under load, for which there may be no other automatic protection. Otherwise, one would apply the negative-phase-sequence-current relay only when the back-up-relaying equipment of the system could not be relied on to remove unbalanced faults quickly enough in the event of primary-relaying failure. However, there are undoubtedly many locations where back-up relaying will not operate for certain faults. Therefore, one should not generalize on this subject but should get the facts for each application. To determine properly whether additional protection is really necessary is a very complicated study. Where additional protection can be afforded, it should be applied.

LOSS-OF-EXCITATION PROTECTION

When a synchronous generator loses excitation, it operates as an induction generator, running above synchronous speed. Round-rotor generators are not suited to such operation because they do not have amortisseur windings that can carry the induced rotor currents. Consequently, a steam-turbine-generator's rotor will overheat rather quickly from the induced currents flowing in the rotor iron, particularly at the ends of the rotor where the currents flow across the slots through the wedges and the retaining ring, if used. The length of time to reach dangerous rotor overheating depends on the rate of slip, and it may be as short as 2 or 3 minutes. Salient-pole generators invariably have amortisseur windings, and, therefore, they are not subject to such overheating.

The stator of any type of synchronous generator may overheat, owing to overcurrent in the stator windings, while the machine is running as an induction generator. The stator current may be as high as 2 to 4 times rated, depending on the slip. Such overheating is not apt to occur as quickly as rotor overheating.

Some systems cannot tolerate the continued operation of a generator without excitation. In fact, if the generator is not disconnected immediately when it loses excitation, widespread instability may very quickly develop, and a major system shutdown may occur. Such systems are those in which quick-acting automatic generator voltage regulators are not employed. When a generator loses excitation, it draws reactive power from the system, amounting to as much as 2 to 4 times the generator's rated load. Before it lost excitation, the generator may have been delivering reactive power to the system. Thus, this large reactive load suddenly thrown on the system, together with the loss of the generator's reactive-power output, may cause widespread voltage reduction, which, in turn, may cause extensive instability unless the other generators can automatically pick up the additional reactive load immediately.

In a system in which severe disturbances can follow loss of excitation in a given generator, automatic quick-acting protective-relaying equipment should be provided to trip the generator's main and field breakers. An operator does not have sufficient time to act under

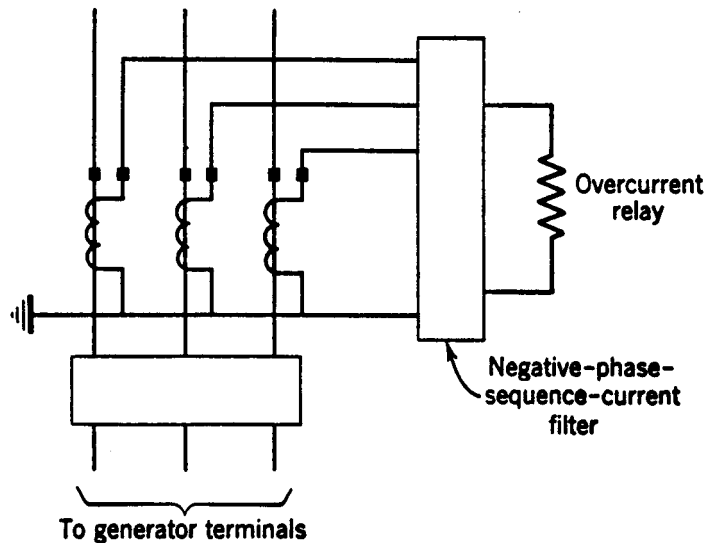

Fig. 19. Negative-phase-sequence-overcurrent relaying for unbalanced stator currents.

such circumstances. Where system disturbances definitely will not follow loss of excitation, an operator will usually have at least 2 or 3 minutes in which to act in lieu of automatic tripping. Sometimes an emergency excitation source and manual throw-over are provided that may make it unnecessary to remove a generator from service. However, an operator can usually do nothing except remove the generator from service, unless the operator

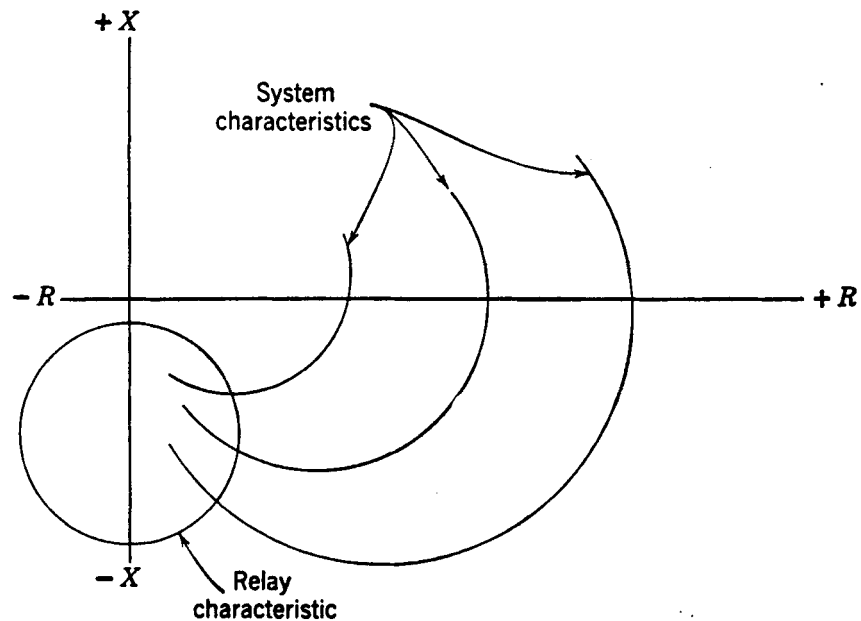

Fig. 20. Loss-of-excitation relay and system characteristics.

himself has accidentally removed excitation. If a loss-of-excitation condition should not be recognized and a generator should run without excitation for an unknown length of time, it ought to be shut down and carefully examined for damage before returning it to service. In systems in which severe disturbances may or may not follow loss of excitation in a given generator, the generator must sometimes be tripped when the system does not require it, merely to be sure that the generator will always be tripped when the system *does* require it.

Undercurrent relays connected in the field circuit have been used quite extensively, but the most selective type of lose-of-excitation relay is a directional-distance type operating from the a-c current and voltage at the main generator terminals.⁴³ Figure 20 shows several loss-of-excitation characteristics and the operating characteristic of one type of loss-of-excitation relay on an $R-X$ diagram. No matter what the initial conditions, when excitation is lost, the equivalent generator impedance traces a path from the first quadrant into a region of the fourth quadrant that is entered only when excitation is severely reduced or lost. By encompassing this region within the relay characteristic, the relay will operate when the generator first starts to slip poles and will trip the field breaker and disconnect the generator from the system before either the generator or the system can be harmed. The generator may then be returned to service immediately when the cause of excitation failure is corrected.

PROTECTION AGAINST ROTOR OVERHEATING BECAUSE OF OVEREXCITATION

It is not the general practice to provide protection against overheating because of overexcitation. Such protection would be provided indirectly by the stator-overheating protective equipment or by excitation-limiting features of the voltage-regulator equipment.

PROTECTION AGAINST VIBRATION

Protective-relaying practices and equipment that are described under the headings “Protection against Rotor Overheating because of Unbalanced Three-Phase Stator Currents” and “Field Ground-Fault Protection” prevent or minimize vibration under those circumstances. If the vibration-detecting equipment recommended under the latter heading is used, it will also provide protection if vibration results from a mechanical failure or abnormality. For a steam turbine, it is the general practice to provide vibration recorders that can also be used if desired to control an alarm or to trip. However, it is not the general practice to trip.

PROTECTION AGAINST MOTORING

Motoring protection is for the benefit of the prime mover or the system, and not for the generator. However, it is considered here because, when protective-relaying equipment is used, it is closely associated with the generator.

Steam Turbines. A steam turbine requires protection against overheating when its steam supply is cut off and its generator runs as a motor. Such overheating occurs because insufficient steam is passing through the turbine to carry away the heat that is produced by windage loss. Modern condensing turbines will even overheat at *outputs* of less than approximately 10% of rated load.

The length of time required for a turbine to overheat, when its steam is completely cut off, varies from about 30 seconds to about 30 minutes, depending on the type of turbine. A condensing turbine that operates normally at high vacuum will withstand motoring much longer than a topping turbine that operates normally at high back pressure.

Since the conditions are so variable, no single protective practice is clearly indicated. Instead, the turbine manufacturer's recommendations should be sought in each case. The manufacturer will probably have turbine accessories that will provide an alarm or will shut down the equipment, as required.

For a turbine that will not overheat unless its generator runs as a motor, sensitive power-directional-relaying equipment has been widely used. One type of such relaying equipment is able to operate on power flowing into the generator amounting to about 0.5% of the generator's rated full-load watts. In general, the protective equipment should operate on somewhat less than about 3% of rated power. Sufficient time delay should be provided to prevent undesired operation on transient power reversals such as those occurring during synchronizing or system disturbances.

Hydraulic Turbines. Motoring protection may occasionally be desirable to protect an unattended hydraulic turbine against cavitation of the blades. Cavitation occurs on low water flow that might result, for example, from blocking of the trash gates. Protection is not generally provided for attended units. Protection can be provided by power-directional-relaying equipment capable of operating on motoring current of somewhat less than about 2.5% of the generator's full-load rating.

Diesel Engines. Motoring protection for Diesel engines is generally desirable. The generator will take about 15% of its rated power or more from the system, which may constitute an undesirably high load on the system. Also, there may be danger of fire or explosion from unburned fuel. The engine manufacturer should be consulted if one wishes to omit motoring protection.

Gas Turbines. The power required to motor a gas turbine varies from 10% to 50% of full-load rating, depending on turbine design and whether it is a type that has a load turbine separate from that used to drive the compressor. Protective relays should be applied based primarily on the undesirability of imposing the motoring load on the system. There is usually no turbine requirement for motoring protection.

OVERSPEED PROTECTION

Overspeed protection is recommended for all prime-mover-driven generators. The over speed element should be responsive to machine speed by mechanical, or equivalent electrical, connection; if electrical, the overspeed element should not be adversely affected by generator voltage.

The overspeed element may be furnished as part of the prime mover, or of its speed governor, or of the generator; it should operate the speed governor, or whatever other shut-down means is provided, to shut down the prime mover. It should also trip the generator circuit breaker; this is to prevent overfrequency operation of loads connected to the system supplied by the generator, and also to prevent possible overfrequency operation of the generator itself from the a-c system. The overspeed device should also trip the auxiliary breaker where auxiliary power is taken from the generator leads. In certain cases, an overfrequency relay may be suitable for providing both of these forms of protection. However, a direct-connected centrifugal switch is preferred.

The overspeed element should usually be adjusted to operate at about 3% to 5% above the full-load rejection speed. Supplementary overspeed protection is required for some forms of gas turbines. Whether such protection is required for any given turbine, and what its adjustment should be, should be specified by the turbine manufacturer.

EXTERNAL-FAULT BACK-UP PROTECTION

Generators should have provision against continuing to supply short-circuit current to a fault in an adjacent system element because of a primary relaying failure. Simple inverse-time overcurrent relaying is satisfactory for single-phase-to-ground faults. For phase faults, a voltage-restrained or voltage-controlled inverse-time-overcurrent relay or a single-step distance-type relay with definite time delay—is preferred.

Which of the two general types of phase relay to use depends on the types of relays with which the back-up relays must be selective. Thus, if the adjacent circuits have inverse-time-overcurrent relaying, the voltage-restrained or -controlled inverse-time-overcurrent relay should be used. But, if the adjacent circuits have high-speed pilot or distance relaying, then the distance-type relay should be used.

Inverse-time-overcurrent relays for phase-fault-back-up protection are considered decidedly inferior; owing to the decrement in the short-circuit current put out by a generator, the margin between the maximum-load current and the short-circuit current a short time after the fault current has started to flow is too narrow for reliable protection.

Where cross-compounded generators are involved, external-fault-back-up-relaying equipment need be applied to only one unit.

Negative-phase-sequence-overcurrent-relaying equipment to prevent overheating of the generator rotor as a consequence of prolonged unbalanced stator currents is not here considered a form of external-fault-back-up protection. Instead, such relaying is considered a form of primary relaying, and it is treated as such elsewhere. A back-up relay should have characteristics similar to the relays being backed up, and a negative-phase-sequence-overcurrent relay is not the best for this purpose, apart from the fact that such a relay would not operate for three-phase faults.

When a unit generator-transformer arrangement is involved, the external-fault-back-up relay is generally energized by current and voltage sources on the low-voltage side of the power transformer. Then the connections should be such that the distance-type units measure distance properly for high-voltage faults.

BEARING-OVERHEATING PROTECTION

Bearing overheating can be detected by a relay actuated by a thermometer-type bulb inserted in a hole in the bearing, or by a resistance-temperature-detector relay, such as that described for stator-overheating protection, with the detector embedded in the bearing. Or, where lubricating oil is circulated through the bearing under pressure, the temperature of the oil may be monitored if the system has provision for giving an alarm if the oil stops flowing.

Such protection is provided for all unattended generators where the size or importance of the generator warrants it. Such protection for attended generators is generally only to sound an alarm.

OTHER MISCELLANEOUS FORMS OF PROTECTION

The references given later under the heading “Protection of the Prime Mover” describe other protective features provided for generators and their associated equipment. These forms of protection are generally mechanical and are not generally classified with protective-relaying equipment.

GENERATOR POTENTIAL-TRANSFORMER FUSING AND FUSE BLOWING

Unless special provision is made, the blowing of a potential-transformer fuse may cause certain relays to trip the generator breakers. Such relays are those types employing voltage restraint, such as voltage-controlled or distance-type relays used for loss-of-excitation or external-fault-back-up protection. It is not necessarily a complete loss of voltage that causes such undesired tripping; with a three-phase voltage supply consisting of two or three potential transformers, the blowing of a fuse may change the magnitude and phase relations of certain secondary voltages through the mechanism of the potentiometer effect of other devices connected to the PT's. Such an effect can cause a relay to operate undesirably when complete loss of voltage would not cause undesired operation.

The proper solution to this problem is not the complete removal of all fuses. The preferred practice is to fuse both primary and secondary circuits.² However, the secondary fuses may be omitted from the circuits of relays or other devices where correct operation is so essential that it is “preferable to incur hazards associated with the possible destruction of the PT by a sustained secondary short circuit rather than to risk interruption of the voltage supply to such devices as the result of a momentary short circuit.”² Advantage is usually taken of this clause not to fuse the secondary, and the record with this practice has been very good. Primary fuses should not be omitted, but they must be chosen so that they will not blow on magnetizing-current inrush or other transients.⁴⁴

When secondary fusing is used because of the better protection that it gives the potential transformers, the exposure of critical devices to the effects of accidental fuse blowing can be minimized by fusing their circuits separately, or by fusing all circuits except those of the critical devices.

When separate secondary fusing is not enough assurance against the consequences of fuse blowing, a voltage-balance relay may be used that compares the magnitudes of the voltages of the voltage source under consideration with the voltages of another source that are always approximately equal to the voltages of the first source unless a fuse blows. Such a relay can be arranged to prevent undesired operation of critical relays and to actuate an alarm when a fuse blows. Not only preventing undesired relay operation but also knowing immediately that a fuse has blown are important. With wye-wye potential transformers, a set of auxiliary PT's connected wye-broken-delta, with a voltage relay energized by the voltage across the open corner of the delta, can be used to open the trip circuit when one or more fuses blow.

STATION AUXILIARY PROTECTION

Power-plant auxiliaries are treated somewhat differently from similar equipment used elsewhere. It is generally felt that they deserve higher-quality protective equipment. At the same time, however, certain so-called “essential” auxiliaries are kept in service under manual supervision during overload conditions that would ordinarily call for tripping.^{45,46} Reference 46 stresses the importance of keeping auxiliary motors running during system disturbances, and describes techniques for accomplishing this. Reference 47 is a collection of several papers on the effect of reduced voltage and frequency on power-plant capabilities. The protection of station auxiliaries will be treated in more detail where the protection of motors, transformers, and busses is described.

PROTECTION OF THE PRIME MOVER

Except for the protection against motoring and overspeed, the protection of the prime mover and its associated mechanical equipment is not treated in this book. References to some excellent papers on this subject, and also on the subject of fire protection, are given in the Bibliography.^{8,48}

MOTOR PROTECTION

This section deals with the protection of attended synchronous motors, induction motors, synchronous condensers, and the motors of frequency converters. Motors in unattended stations must be protected against all harmful abnormal conditions.¹ The protection of very small motors is not specifically described, although the same basic principles apply; this subject is treated in detail in the National Electrical Code.³ The practices described here for large motors are at least equal to those covered by the Code, and are generally more comprehensive. However, it is recommended that the Code be consulted whenever it applies. The protection of fire-pump motors is not included here, because it is completely described elsewhere.⁴

SHORT-CIRCUIT PROTECTION OF STATOR WINDINGS

Overcurrent protection is the basic type that is used for short-circuit protection of stator windings. The equipment for this type of protection ranges from fuses for motor voltages of 600 volts and lower, through direct-acting overcurrent tripping elements on circuit breakers, to separate overcurrent relays and circuit breakers for voltages of 2200 volts and higher.

Protection should be provided against a fault in any ungrounded conductor between the interrupting device and the motor, including its stator windings. Where fuses or direct-acting tripping devices are used, there must be one protective element in each ungrounded conductor. Where relays and current transformers are used with so-called “a-c tripping” from the output of the current transformers, a CT and relay are required for each ungrounded conductor. However, if battery or capacitor tripping is provided, three current transformers with two phase relays and one ground relay will suffice for a three-phase circuit whether or not the source neutral is grounded.

Motors Other than Essential Service. For all except “essential-service” motors, it is the practice to provide both inverse-time and instantaneous phase and ground overcurrent relays for automatic tripping. The inverse-time phase relays are generally adjusted to pick up at somewhat less than about 4 times rated motor current, but to have enough time delay so as not to operate during the motor-starting period. The instantaneous phase relays are adjusted to pick up a little above the locked-rotor current. The inverse-time ground relays are adjusted to pick up at no more than about 20% of rated current or about 10% of the maximum available ground-fault current, whichever is smaller. The instantaneous ground-relay pickup should be from about 2.5 to 10 times rated current; this relay may be omitted if the maximum available ground-fault current is less than about 4 times rated current, or if the pickup has to be more than about 10 times rated current to avoid undesired tripping during motor starting or external faults. If a CT, like a bushing CT, is used with all three phase conductors of the motor circuit going through the opening in the core, a very sensitive instantaneous overcurrent relay can be used that will operate for ground faults within about 10% of the winding from the neutral end.

Percentage-differential relaying is provided for large motors. It is the practice of manufacturers² to recommend such protection for motors of the following ratings: (a) 2200 volts to 4999 volts, inclusive, 1500 hp and higher; (b) 5000 volts and higher, 501 hp and higher. The advantage of percentage-differential relaying is that it will provide faster and more sensitive protection than overcurrent relaying, but at the same time it will not operate on starting or other transient overcurrents.

References to excellent articles on the subject of industrial-motor protection are given in the Bibliography.⁴⁹

Essential-Service Motors. For essential-service motors, the inverse-time phase overcurrent relays are usually omitted, leaving the instantaneous phase relays, and the inverse-time and instantaneous ground relays, or the differential relays if applicable. The reason for the omission is to trip the motor breaker automatically only for short circuits and not to trip for any other reason. This is because the tripping of such a motor may force a partial or complete shutdown of a generator or other service with which the motor is associated, and hence any unnecessary tripping must be avoided. As will be seen when we consider stator overheating protection, supplementary protection against phase overcurrents less than locked-rotor values is provided.

STATOR-OVERHEATING PROTECTION

All motors need protection against overheating resulting from overload, stalled rotor, or unbalanced stator currents. For complete protection, three-phase motors should have an overload element in each phase; this is because an open circuit in the supply to the power transformer feeding a motor will cause twice as much current to flow in one phase of the motor as in either of the other two phases, as shown in Fig. 21. Consequently, to be sure that there will be an overload element in the most heavily loaded phase no matter which power-transformer phase is open-circuited, one should provide overload elements in all three phases. In spite of the desirability of overload elements in all three phases, motors rated about 1500 hp and below are generally provided with elements in only two phases, on the assumption that the open-phase condition will be detected and corrected before any motor can overheat.

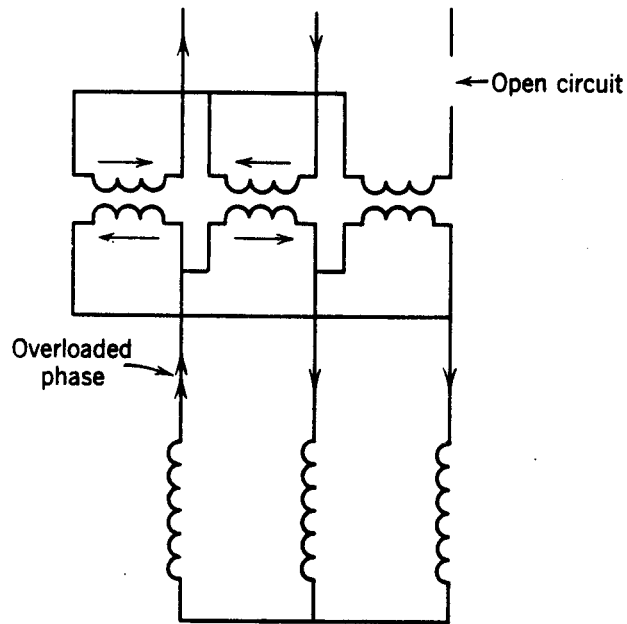

Fig. 21. Illustrating the need for overcurrent protection in each phase.

Single-phase motors require an overload element in only one of the two conductors.

Motors Other than Essential Service. Except for some essential-service motors, whose protection will be discussed later, it is the practice for motors rated less than about 1500 hp to provide either replica-type thermal-overload relays or long-time inverse-time-overcurrent relays or direct-acting tripping devices to disconnect a motor from its source of supply in

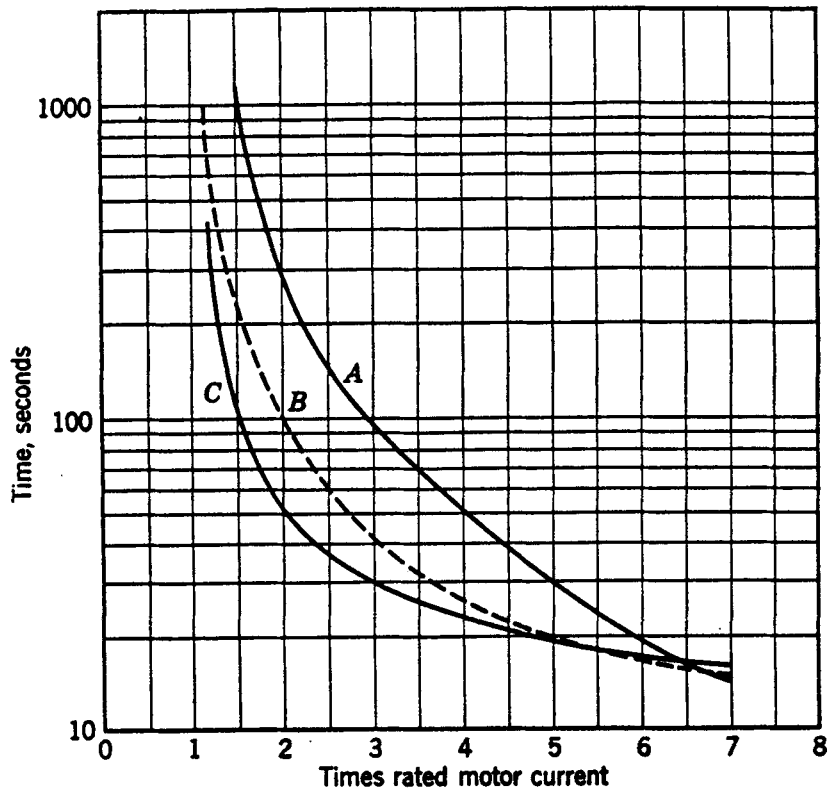

Fig. 22. Typical motor-heating and protective-relay characteristics. A, motor; B, replica relay; C, inverse-time relay.

the event of overload. Which type of relay to use is largely a matter of personal preference. Other things being equal, the replica type will generally provide the best protection because, as shown in Fig. 22, its time-current characteristic more nearly matches the heating characteristic of a motor over the full range of overcurrent; also, it may take into account the heating effect of the load on the motor before the overload condition occurred. The inverse-time-overcurrent relay will tend to “overprotect” at low currents and to “under protect” at high currents, as shown in Fig. 22. However, the overcurrent relay is very easy to adjust and test, and it is self-reset. For continuous-rated motors without service factor or short-time overload ratings, the protective relays or devices should be adjusted to trip at not more than about 115% of rated motor current. For motors with 115% service factor, tripping should occur at not more than about 125% of rated motor current. For motors with special short-time overload ratings, or with other service factors, the motor characteristic will determine the required tripping characteristic, but the tripping current should not exceed about 140% of rated motor current. The manufacturer’s recommendations should be obtained in each case.

The overload relays will also provide protection in the event of phase-to-phase short circuits, and in practice one set of such relays serves for both purposes wherever possible. A survey of the practice of a number of power companies⁴⁵ showed that a single set of long-time inverse-time-overcurrent relays, adjusted to pick up at 125% to 150% of rated motor current, is used for combined short-circuit and overload protection of non-essential auxiliary motors; they are supplemented by instantaneous overcurrent relays adjusted as already described. Such inverse-time overload relays must withstand short-circuit currents without damage for as long as it takes to trip the breaker. Also the minimum requirements as to the number of relays or devices for either function must be fulfilled.

Motors rated higher than about 1500 hp are generally provided with resistance temperature detectors embedded in the stator slots between the windings. If such temperature detectors are provided, a single relay operating from these detectors is used instead of the replica-type or inverse-time-overcurrent relays. Also, current-balance relays capable of operating on about 25% or less unbalance between the phase currents should be supplied. If the motor does not have resistance temperature detectors, but is provided with current-balance relays, a single replica-type thermal overload relay may be substituted for the resistance-temperature-detector relay.

Specially cooled or ventilated motors may require other types of protective equipment than those recommended here. For such motors, the manufacturer’s recommendations should be obtained.

Reference 50 gives more useful information on the subject of industrial-motor protection.

Essential-Service Motors. The protection recommended for some essential-service motors is based on minimizing the possibility of unnecessarily tripping the motor, even though such practice may sometimes endanger the motor. In other words, long-time inverse-time-overcurrent-relays are provided for all motor ratings, but they merely control an alarm and leave tripping in the control of an operator. Then, for motors that can suffer locked rotor, supplementary instantaneous overcurrent relays, adjusted to pick up at about 200% to 300% of rated motor current are used, and their contacts are connected in series with the contacts of the inverse-time-overcurrent relays to trip the motor breaker automatically. The instantaneous relays should be of the high-reset type to be sure that they will reset when the

current returns to normal after the starting inrush has subsided. The protection provided by this type of equipment is illustrated in Fig. 23.

For essential-service motors for which automatic tripping is desired in addition to the alarm for overloads between about 115% of rated current and the pickup of the instantaneous overcurrent relays, thermal relays of either the replica type or the resistance-temperature-detector-type should be used, depending on the size of the motor. Such relays permit operation for overloads as far as possible beyond the point where the alarm will be sounded, but without damaging the motor to the extent that it must be repaired before it can be used again.

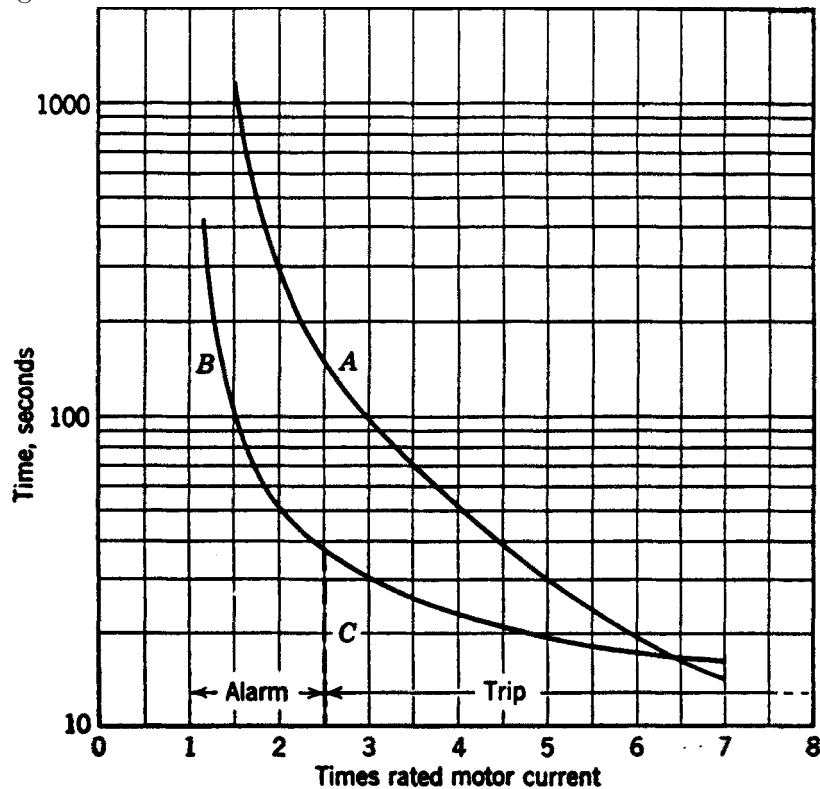

Fig. 23. Protection characteristic for essential-service motors. A, motor; B, inverse-time relay; C, instantaneous relay.

ROTOR-OVERHEATING PROTECTION

Squirrel-Cage Induction Motors. The replica-type or the inverse-time-overcurrent relays, recommended for protection against stator overheating, will generally protect the rotor except where high-inertia load is involved; such applications should be referred to the manufacturer for recommendations. Where resistance-temperature-detector relaying is used, a single replica-type or inverse-time-overcurrent relay should be added for rotor protection during starting.

Wound-Rotor Induction Motors. General recommendations for this type of motor cannot be given except that the rotor may not be protected by the stator-overheating protective equipment that has been described. Each application should be referred to the manufacturer for recommendations.

Synchronous Motors. Amortisseur-overheating protection during starting or loss of synchronism should be provided for all "loaded-start" motors. (A loaded-start motor is any

motor other than either a synchronous condenser or a motor driving a generator; it includes any motor driving a mechanical load even though automatic unloading means may be employed.) Such protection is best provided by a time-delay thermal overload relay connected in the field-discharge circuit.⁵¹

Amortisseur-overheating protection is not required for “unloaded-start” motors (synchronous condensers or motors driving generators). An unloaded-start motor is not likely to fail to start on the application of normal starting voltage. Also, loss-of-synchronism protection that is provided either directly or indirectly will provide the necessary protection. An exception to the foregoing is a condenser or a motor that has an oil-lift pump for starting.

Where stator-overheating protection is provided by current-balance-relaying equipment, the amortisseur is indirectly protected also against unbalanced phase currents.

Protection against field-winding overheating because of prolonged overexcitation should be provided for synchronous motors or condensers with automatic voltage regulators without automatic field-current-limiting features. A thermal overload relay with time delay or a relay that responds to an increase in the field-winding resistance with increasing temperature may be used. In an attended station, the relay would merely control an alarm.

LOSS-OF-SYNCHRONISM PROTECTION

All loaded-start synchronous motors should have protection against loss of synchronism, generally arranged to remove the load and the excitation temporarily and to reapply them when permissible. Otherwise, the motor is disconnected from its source.

For unloaded-start motors except the synchronous motor of a frequency converter, the combination of undervoltage protection, loss-of-excitation protection, and the d-c generator overcurrent protection that is generally furnished will provide satisfactory loss-of-synchronism protection. Should additional protection be required, it can be provided by an inverse-time-overcurrent relay energized by the current in the running connection and arranged to trip the main breaker. Usually, automatic resynchronizing is not required.

All frequency converters interconnecting two systems should have loss-of-synchronism protection on the synchronous-machine side. With synchronous-synchronous sets, protection may be required on both sides. The protective-relaying equipment should be arranged to trip the main breaker on its side.

UNDERVOLTAGE PROTECTION

All a-c motors except essential-service motors should have protection against undervoltage on at least one phase during both starting and running. For polyphase motors larger than about 1500 hp, polyphase undervoltage protection is generally provided.

Wherever possible, the protective equipment should have inverse-time-delay characteristics.

“Undervoltage release,” which provides only temporary shutdown on voltage failure and which permits automatic restart when voltage is re-established, should not be used with such equipment as machine tools, etc., where such automatic restart might be hazardous to personnel or detrimental to process or equipment.

LOSS-OF-EXCITATION PROTECTION

All unloaded-start synchronous motors that do not have loss-of-synchronism protection as described elsewhere, and that do not have automatic voltage regulators, should have loss-of-excitation protection in the form of a low-set, time-delay-reset undercurrent relay whose coil is in series with the field winding.

If a motor has loss-of-synchronism protection, amortisseur-over-heating protection, and stator-overheating protection, these equipments indirectly provide loss-of-excitation protection.

FIELD GROUND-FAULT PROTECTION

The same equipment as that described for generators may be used if the size or importance of the motor warrants it.

BIBLIOGRAPHY

1. "Automatic Station Control, Supervisory and Telemetering Equipments," *Publ. C37.2*, American Standards Association, Inc., 70 East 45th St., New York 17, N.Y.
2. "Power Switchgear Assemblies," *Publ. SG5*, National Electrical Manufacturers Assoc., 155 East 44th St., New York 17, N. Y.
3. *National Electrical Code*, National Electrical Board of Fire Underwriters, 85 John St., New York 38, N. Y.; 222 West Adams St., Chicago 6, Ill.; 465 California St., San Francisco 4, Calif.
4. "Standards for the Installation and Operation of Centrifugal Fire Pumps," *Publ. 20*, National Fire Protection Assoc., 60 Battery March St., Boston 10, Mass.
5. *Silent Sentinels*, Westinghouse Electric Corp., Meter Division, Newark, N. J.
6. *The Art of Protective Relaying and An Introduction to Protective Relays*, General Electric Co., Schenectady 5, N. Y.
7. "Bibliography of Relay Literature," by AIEE Committee:

Years of Publication	<i>AIEE Trans.</i>		
	Vol.	Year	Pages
1927-1939	60	1941	1435-1447
1940-1943	63	1944	705-709
1944-1946	67, Pt. I	1948	24-27
1947-1949	70, Pt. I	1951	247-250
1950-1952	74, Pt. III	1955	45-48

8. "Protection of Turbine Generators and Boilers by Automatic Tripping," by H. A. Bauman, J. M. Driscoll, P. T. Onderdonk, and R. L. Webb, *AIEE Trans.*, 72, Part III (1953), pp. 1248-1255. Discussions, pp. 1255-1260.

"Human Error Causes Half Power Plant Outages," *Elec. World*, Nov. 15, 1954, p. 112.

9. "Relay Protection of A-C Generators," by AIEE Committee, *AIEE Trans.*, 70 (1951), pp. 275-281. Discussions, pp. 281-282.
10. "Power Systems Engineering Faces a New Challenge," by E. H. Snyder, *EEI Bulletin*, June, 1954, pp. 193-196.
11. "Principles and Practices of Relaying in the United States," by E. L. Harder and W. E. Marter, *AIEE Trans.*, 67 (1948), pp. 1075-1081.
12. "Matching Ratio Errors Improves Differential Relays," by E. C. Wentz, *Elec. World*, 99, No. 3 (January 16, 1932), pp. 154-155.
13. "A High-Speed Differential Relay for Generator Protection," by W. K. Sonnemann, *AIEE Trans.*, 69 (1940), pp. 608-612. Discussions, pp. 1250-1252.
14. "A New Generator Differential Relay," by A. J. McConnell, *AIEE Trans.*, 62 (1943), pp. 11-13. Discussions, p. 381.
15. "Characteristics of Split-Phase Currents As a Source of Generator Protection," by H. R. Sills and J. L. McKeever, *AIEE Trans.*, 72, Part III (1953), pp. 1005-1013. Discussions, pp. 1013-1016.
16. "Generator Protected by a 'Floating' CT," by E. G. Ratz, *Elec. World*, 124 ((August 18, 1945), pp. 115-116.
17. "Shipshaw Relay Protection," by J. T. Madill and F. H. Duffy, *AIEE Trans.*, 68, Part I (1949), pp. 50-58.
18. "Protect Generator from Internal Faults," by Giuseppe Calabrese, *Elec. World*, 109 (May 21, 1938), p. 76 (1704). Correction, 110, No. 7 (Aug. 12, 1938), p. 435.
19. "Application Guide for the Grounding of Synchronous Generator Systems," by AIEE Committee, *AIEE Trans.*, 72, Part III (1953), pp. 517-526. Discussions, pp. 526-530. (Also included in *AIEE No. 954*, Oct., 1954.)
20. *Electrical Transmission and Distribution Reference Book*, Westinghouse Electric Corp., East Pittsburgh, Pa.
21. Discussions of Reference 19, pp. 526-530.
22. "Neutral Grounding Devices," *Publ. 32*, The American Institute of Electrical Engineers, 33 West 39th St., New York 18, N. Y.
23. "Guide for Loading Oil-Immersed Distribution and Power Transformers," *Publ. C57. 32*, American Standards Assoc., Inc., 70 East 45th St., New York 17, N. Y.
24. "Iron Burning Caused by Low Current Arcs," by R. Pohl, *AEG Mitteilungen*, Berlin, Germany, Jan., 1930.
25. "Ground-Fault Neutralizer Grounding of Unit-Connected Generators," by H. R. Tomlinson, *AIEE Trans.*, 72, Part III (1953), pp. 953-960.
26. Discussions of Reference 25, pp. 960-961.
27. "Sensitive Ground Relaying of A-C Generators," by E. T. B. Gross, *AIEE Trans.*, 71, Part III (1952), pp. 539-541 Discussions, pp. 541-544.
28. "Rotating Electrical Machinery," *Publ. C50-1943*, American Standards Assoc., 70 East 45th St., New York 17, N. Y.

29. "Temperature Drop to Resistance Temperature Detector in Stator Windings of Turbine Generators," by R. P. Jerrard, *AIEE Trans.*, 73, Part III (1954), pp. 665-669. Discussions, pp. 669-670.
- "Controls for Operation of Steam Turbine-Generator Units," by O. N. Bryant, C. C. Sterrett, and D. M. Sauter, *AIEE Trans.*, 73, Part III (1954), pp. 79-88.
- "Turbine Generator Stator Winding Temperatures at Various Hydrogen Pressures," by J. R. M. Alger, C. E. Kilbourne, and D. S. Snell, *AIEE Trans.*, 74, Part III (1955), pp. 232-250. Discussions, pp. 250-251.
30. Discussions of Reference 31, pp. 1355-1357.
31. "Vibration Protection for Rotating Machinery," by R. L. Webb and C. S. Murray, *AIEE Trans.*, 63 (1944), pp. 534-537.
32. "Detection of Grounds in Generator Field Windings," by J. E. Barkle, C. C. Sterrett, and L. L. Fountain, *AIEE Trans.*, 74, Part III (1955), pp. 467-470. Discussions, pp. 470-472.
33. "Bearings Pitted by Ground Alarm Surges," by T. M. Blakeslee, *Elec. World*, 119 (Jan. 9, 1943), pp. 57 (81)-58 (82).
34. "Turbine Generator Rotor Heating during Single Phase Short Circuits," by M. D. Ross and E. I. King, *AIEE Trans.*, 72, Part III (1953), pp. 40-45.
35. "Effects of Negative Sequence Currents on Turbine-Generator Rotors," by E. I. Pollard, *AIEE Trans.*, 72, Part III (1953), pp. 404-400. Discussions, p. 406.
36. "Short-Circuit Capabilities of Synchronous Machines for Unbalanced Faults," by P. L. Alger, R. F. Franklin, C. E. Kilbourne, and J. B. McClure, *AIEE Trans.*, 72, Part III (1953), pp. 394-403. Discussions, pp. 403-404.
37. "Rotating Electrical Machinery," *Publ. C50*, American Standards Assoc. Inc., 70 East 45th St., New York 17, N. Y.
38. "Protection of Generators against Unbalanced Currents," by J. E. Barkle, and W. E. Glassburn, *AIEE Trans.*, 72, Part III (1953), pp. 282-285. Discussions, pp. 285-286.
- "Backup Protection for Generators," by E. T. B. Gross and L. B. LeVesconte, *AIEE Trans.*, 72, Part III (1953), pp. 585-589. Discussions, pp. 589-592.
39. "A Negative-Phase-Sequence-Overcurrent Relay for Generator Protection," by W. C. Morris and L. E. Goff, *AIEE Trans.*, 72, Part III (1953), pp. 615-618. Discussions, pp. 618-621.
40. "Application of Relays for Unbalanced Faults on Generators," by J. E. Barkle and Frank Von Roeschlaub, *AIEE Trans.*, 72, Part III (1953), pp. 277-281. Discussions, pp. 281-282.
41. "Generator Negative-Sequence Currents for Line-to-Line Faults," by R. F. Lawrence and R. W. Ferguson, *AIEE Trans.*, 72, Part III (1953), pp. 9-16.
42. Discussion by Mr. R. L. Webb of "Turbine Generator Controls, Protections, and Accessories," by G. W. Cunningham and M. A. Eggenberger, *AIEE Trans.*, 73, Part III (1954), pp. 455-464. Discussions, pp. 464-465.
43. "A New Loss-of-Excitation Relay for Synchronous Generators," by C. R. Mason, *AIEE Trans.*, 68 (1949), pp. 1240-1245.

- “Loss-of-Field Protection for Synchronous Machines,” by R. L. Tremaine and J. L. Blackburn, *AIEE Trans.*, 73, Part III (1954), pp. 765-772. Discussions, pp. 772-777.
44. “How to Fuse Potential Transformer Primary Circuits,” by C. L. Shuck, *Gen. Elec. Rev.*, 44 (July 1941), p. 385.
45. “Protection of Powerhouse Auxiliaries,” by AIEE Committee, *AIEE Trans.*, 65 (1946), pp. 746-750. Discussions, pp. 1115-1116.
46. “Electric Drives for Steam-Electric Generating-Station Auxiliaries,” by Wm. R. Brownlee and J. A. Elzi, *AIEE Trans.*, 64 (1945), pp. 741-745.
47. “Symposium on the Effect of Low Frequency and Low Voltage on Thermal Plant Capability and Load Relief during Power System Emergencies,” *AIEE Trans.*, 73, Part III (1954), pp. 1628-1668.
48. “Controls for Operation of Steam Turbine-Generator Units,” by O. N. Bryant, C. C. Sterrett, and D. M. Sauter, *AIEE Trans.*, 73, Part III (1954), pp. 79-88.
- “Turbine and Boiler Protection and Interlocking on the American Gas and Electric Co. System,” by H. C. Barnes and C. P. Lugin, *AIEE Trans.*, 73, Part III (1954), pp. 884-893. Discussions, pp. 893-894.
- “Turbine Generator Controls, Protections, and Accessories,” by G. W. Cunningham and M. A. Eggenberger, *AIEE Trans.*, 73, Part III (1954), pp. 455-464. Discussions, pp. 464-465.
- “Fire Protection in Electric Stations,” by H.A. Bauman and W. E. Rossnagel, *AIEE Trans.*, 70 (1951), pp. 1040-1045.
49. “Protection of Branch Circuits for Auxiliary Motors,” by William Deans, *Iron Steel Engr.*, June, 1939, pp. 17-25. Discussions, pp. 25-30.
- “Selecting A-C Overcurrent Protective Device Settings for Industrial Plants,” by F. P. Brightman, *AIEE Trans.*, 71, Part II (1952), pp. 203-211.
- “More about Setting Industrial Relays,” by F. P. Brightman, *AIEE Trans.*, 73, Part III-A (1954), pp. 397-405. Discussions, pp. 405-406.
- “Relay Protective Methods for Steel Mill Service,” by H. A. Travers, *Iron Steel Engr.*, Nov., 1939, pp. 36-43.
- Magnetic Control of Industrial Motors*, by G. W. Neumann, John Wiley & Sons, New York, 1954.
50. “Selection of Thermal Overload Motor Protection,” by C. W. Kuhn, *Elec. World*, April 1, 1944, pp. 61-63 (121, pp. 1225-1227).
- “Determining the Correct Type of Thermal Protection for Electric Motors Used in the Pipe Line Industry,” by Bradford Kleinman, *Petroleum Engr.*, October, 1953, pp. D-14 to D-18.
- “Selecting Thermal Relays to Protect Three-Phase Motors,” by H. Wilson, *Power*, 77, No. 2, February, 1933, pp. 78-80.
51. “Protecting Squirrel-Cage Winding of Synchronous Motors,” by M. N. Halberg, *Elec. World*, November 11, 1933, p. 627.