



**Grid Solutions**  
a GE and Alstom joint venture

MEASUREMENTS PRODUCT SOLUTIONS

# BiTRONICS M65x

## Transducers and measurement centres

The M65x provides high accuracy measurements and flexible communications

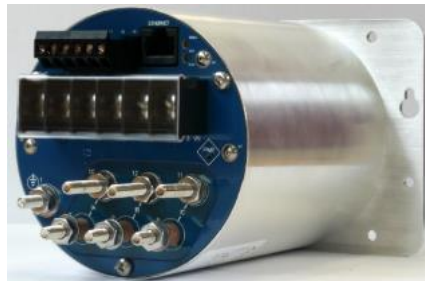

## Measurements and communications

BiTRONICS products have been providing excellence in digital metering for local indication and SCADA communications for over 15 years. The BiTRONICS M65x is a family of multifunction transducers and measurement centres with comprehensive measurement capabilities. The M65x measurement centres have an incomparable display, are simple to set up and use, and offer superior communications flexibility.

### THERE ARE 3 PRODUCTS IN THE M65X RANGE

- M650 measurement centre
- M651 transducer
- M653 measurement centre with 3 sets of displays

### APPLICATIONS

- Digital front-end to SCADA systems
- Intelligent Electronic Device (IED) interfacing to RTUs and PLCs
- Local indication of substation conditions
- Plant equipment, line, power & energy monitoring
- Voltage control, power factor control, and load shedding

### M65x OFFERS

- Accuracy 0.1%, Class 0.2S energy
- RS232, RS485 and Ethernet communications options
- Modbus and DNP (level 2) protocols
- Programmable using integral web-server
- Optional analogue outputs
- Optional Ethernet fibre optic communications
- Optional split core CT inputs for connection on to existing CT secondary wiring

### CUSTOMER BENEFITS

- High accuracy measurements
- Flexible Modbus and DNP3.0 communications
- Local and remote display of values, and programming
- Designed for unconditioned environments



## FEATURES

Multifunction configurable transducers and measurement centres with LED displays

Configurable connections for 3-phase, balanced and unbalanced loads

0.1% measurement accuracy, Class 0.2S energy, true RMS

Configuration using web-server on Ethernet service port

Optional RS232 , RS485 and Ethernet communications supporting MODBUS and DNP3 (level 2)

Universal AC/DC power supply as standard with optional monitoring

Optional Ethernet fibre-optic communications for electrically noisy environments

High visibility LED displays with definition of units

3 sets of 3 LED displays on 3U x 19inch rack mounted panel (M653)

Optional analogue outputs

Operation from +70°C down to - 40°C

Optionally supplied with clamp on CTs for 5A secondary circuits

## BENEFITS

Many site applications can be fulfilled from a single product family with front and back of panel mounting versions

Easy to specify the products for any application, including when full details are not available

Accurate measurements of any electrical network regardless of distortion

Only standard web browser required on PC to programme devices

Allows connection to most remote energy management, DCS and SCADA systems

Power supply suits most site requirements

Fibre optic from source, external fibre optic converters not required

Displays can be seen and understood in all light conditions

Important 3-phase measurements can be displayed from the same meter. i.e. volts, current and watts for all 3 phases

Allows integration into systems requiring analogue signals for monitoring and control

Can be operated in unconditioned environments

Can be retrofitted into operating systems without requiring a shutdown, whilst maintaining performance of the instrument



Rear view standard M65x



M650 front view



M653 front view

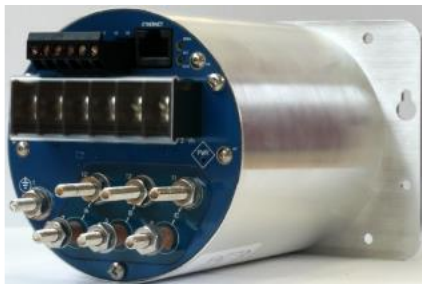

M651 transducer

## MEASUREMENT CENTRES

The M650 and M653 emphasise simplicity. Basic settings can be programmed using the front display buttons. Basic and advanced settings are easily configured through the Ethernet service port. Pre-set register/point sets and display screens coupled with the universal power supply and universal wiring make it easy to go from the box to up and running in no time.

The M653 meters have three incomparable sets of displays, are simple to set up and use, and offer superior communications flexibility. Having three separate sets of displays in one panel allows for fast identification of three-phase conditions without scrolling. Standard 19" panel mounting and wiring for power, inputs and communications to only one meter further simplify installation. The M653 is also available in a panel mount version.

## DISPLAY

- 3-line at once, easy-to-read, long-life LED displays that can be read from far away in all substation conditions including bright sunlight
- Ultimate precision with five digits per line
- Instant recognition of the displayed function from the trademark alphanumeric display of engineering units
- Easy setup and scrolling from front display with "Touch-Sense" buttons.
- On M653 the left and right displays are easily populated via arrow keys that transfer the currently displayed values from the centre display
- Ultimate flexibility by utilizing pre-set measurement display screens or customizing screens including engineering units

## TRANSDUCER

The M651 emphasizes simplicity. Basic and advanced settings can be easily configured through the Ethernet service port. Pre-set register/point sets coupled with the universal power supply and universal wiring make it easy to go from the box to up and running in no time.

The mounting plate and design of M651 allows it to be mounted in an existing 4 inch round cut out or surface mounted.

## FIBRE-OPTIC PORT

The M65x has the option of a fibre-optic communications port which replaces the standard Ethernet port, with Modbus and DNP3 protocols enabled over Ethernet. This ensures that in electrically noisy environments the communications signals are run over fibre-optics from source without the need for a copper connection to the closest Ethernet switch. The fibre-optic port is fitted with a LC connector.

## All of the M65x range offers:

### COMMUNICATIONS

- DNP3 or Modbus protocol available via configurable RS-232/RS-485 serial port.
- DNP3 includes Class 0, 1, 2, and 3 events and configurable address point list.
- No need for PC software - Ethernet service port provides access to web server in the instrument so meters can be interfaced with just a web browser for viewing and configuration
- Optional Ethernet protocol support for DNP3 or Modbus TCP
- Optional fibre port that replaces the standard Ethernet service port and includes Modbus and DNP3 Ethernet protocol support
- Optional analogue output to interface with older generation RTUs
- An option of both standard secondary "optimal resolution" or primary units makes communications with SCADA/RTU more flexible

### MEASUREMENTS

- Comprehensive measurement set including demand and harmonic values
- 0.2% revenue accuracy (IEC 62053-22, 0.2S: ANSI C12.20, 0.2 CA)
- .001 Hz accuracy for frequency
- Updates every 100 ms

### BUILT FOR THE SUBSTATION

- Wide-range universal power supply for all substation installations
- Rugged aluminium case
- Reduce inventory cost as one model covers all wiring options
- Easy to mount with standard 4" round meter or 3U high, 19" panel

### SPECIFICATIONS:

<b>Dimensions:</b>	M650 114 mm (4.5") (w) x 114 mm (4.5") (h) x 165 mm (6.5") (d) M651 133 mm (5.25") (w) x 102 mm (4.0") (h) x 163 mm (6.4") (d) M653 483 mm (19") (w) x 133 mm (5.25") (h) x 165 mm (6.5") (d)
<b>Weight:</b>	0.82 Kg (1.8 lbs) or 1.59 Kg (3.5 lbs).
<b>Power Supply:</b>	Universal 48-250 V dc / 55-240 V ac nominal
<b>Current Inputs:</b>	1 or 5 A nominal to maximum of 2 A or 10 A (2 x overload)
<b>Voltage Inputs:</b>	120 V ac nominal, 45-65 Hz
<b>Outputs:</b>	<ul style="list-style-type: none"><li>• Optional configurable RS-232/RS-485 port , configurable from 9600 bps to 115.2 kbps</li><li>• Standard RJ45 10BaseT/100BaseTX port for service port functions, optional Modbus or DNP3 TCP/IP support</li><li>• Optional LC 100Base FX fibre port with Modbus or DNP3 TCP/IP support</li></ul>
<b>Optional transducer output:</b>	Three 0-1 mA (active) or 4-20 mA (loop powered, passive)
<b>Environmental:</b>	<ul style="list-style-type: none"><li>• Operating temperature range -40 °C to +70 °C</li><li>• storage temperature -40 °C to +85 °C</li><li>• Humidity 0-95 % non-condensing</li><li>• Surge withstand to ANSI/IEEE C37.90.1: 2002</li></ul>



**MEASUREMENTS:**

Basic measurement quantities are calculated and updated every 100ms. These quantities include RMS Amperes and RMS Volts, Watts, VARs, VAs, Power Factor, all harmonic-based measurements (such as fundamental-only quantities), Energy, and Frequency, and Phase Angle.

The specific protocol used to access the data may affect the data that is available, or the format of that data. The appropriate protocol manual includes all of the details.

The M65x measures all signals at an effective rate of 64 samples/cycle, accommodating fundamental signal frequencies from 45 to 65 Hz. Samples of all bus signals are taken using a 16-Bit A/D converter, effectively creating 64 "snapshots" of the system voltage and current per cycle.

The sampling rate is synchronized to the frequency of any of the bus voltages prioritized as follows: V1A-N, V1B-N, V1C-N. This is the frequency reported as the "System Frequency". The sampling rate is the same for all channels.

**AVAILABLE MEASUREMENTS AND SETTINGS**

Amps A, B, C, Residual	Heartbeat
Average Volts AN, BN, CN, AB, BC, CA	K-factor Amps A
Average (Max.) Volts AN, BN, CN, AB, BC, CA	K-factor Amps B
Average (Min.) Volts AN, BN, CN, AB, BC, CA	K-factor Amps C
Average Watts A, B, C, Total	K-factor Amps Residual
Average (Max.) Watts A, B, C, Total	Meter Type
Average (Min.) Watts A, B, C, Total	Phase Angle Amps A, B, C
Average VARs A, B, C, Total	Phase Angle Volts A, B, C
Average (Max.) VARs A, B, C, Total	Phase Angle Volts AB, BC, CA
Average (Min.) VARs A, B, C, Total	Power Factor A, B, C, Total
Average VAs A, B, C, Total	Protocol Version
Average (Max.) VAs A, B, C, Total	PT Scale Factor
Average (Min.) VAs A, B, C, Total	PT Scale Factor Divisor
Class 0 Response Setup	TDD Amps A, B, C, Residual
CT Scale Factor	TDD Denominator A, B, C
CT Scale Factor Divisor	THD Volts AN, BN, CN, AB, BC, CA
Demand (Max.) Amps A, B, C, Residual	VA-Hrs
Demand (Max.) Fund. Amps A, B, C, Residual	VAR-Hrs Lag
Demand Amps A, B, C, Residual	VAR-Hrs Lead
Demand Fundamental Amps A, B, C, Residual	VARs A, B, C, Total
Displacement Power Factor A, B, C	VAs A, B, C, Total
Displacement Power Factor Total	Volts AN, BN, CN, AB, BC, CA
Factory Version Hardware	Volts Aux
Factory Version Software	Watt-Hrs Net
Frequency	Watt-Hrs Normal
Fund. Amps A, B, C, Residual	Watt-Hrs Reverse
Fund. Volts AN, BN, CN, AB, BC, CA	Watts A, B, C, Total
Health	



## WEB-SERVER PROGRAMMING

The M65x are programmed using the integral web-server interface, only a standard web-browser is required on the PC.

Enter the M65x's IP address into the internet browser to connect with the M65x web page interface. Internet browsers supported are Firefox, Internet Explorer, Safari and Google Chrome. The Home page screen should appear as shown.

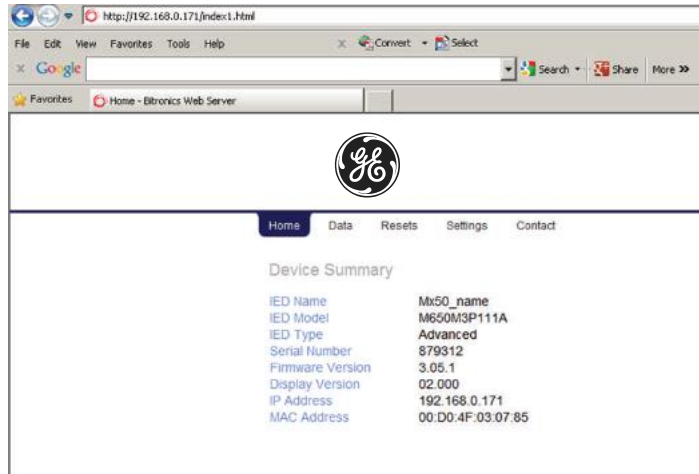

The web-server can be used for the local and remote programming of the device.

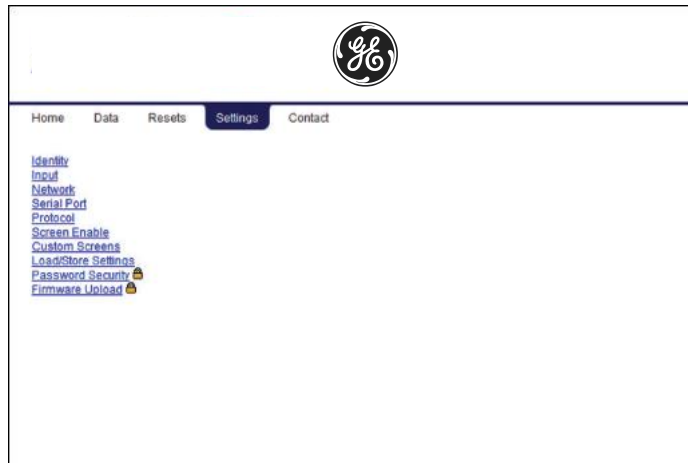

The web-server can also be used for viewing the measurement data, instantaneous or demands.

Live Data View

**Instantaneous** Demands

	Amps	Volts		Volts
Phase A	0.000	123.29	A-B	0.08
Phase B	0.000	123.29	B-C	0.11
Phase C	0.000	123.33	C-A	0.09
Residual	0.000			

	Watts	VARs	VAs	PF
Phase A	0.0	0.0	0.0	0.000
Phase B	0.0	0.0	0.0	0.000
Phase C	0.0	0.0	0.0	0.000
Total	0	0	0	0.000

Energy Used (+kWh)	101
Energy Produced (-kWh)	121
Energy Lag (+kVARh)	154
Energy Lead (-kVARh)	76

VT Scaling	1.0000 : 1
CT Scaling	5.0000 : 5

Frequency	60.013	Health	0000 0000
Time Between Polls	1.004 sec	Heartbeat	12

### SPLIT CORE CTs

The M65x usually connects to standard, installed, CTs but has the option of connecting to split core CTs.

In applications where the main measurement CT is fully operational, new measurement devices need to be installed without affecting the existing wiring. To allow this the M65x range includes versions which are supplied with split core CTs which can be fitted around the secondary wiring of the installed CT.

The split core CTs are manufactured from heat-treated high-permeability ("superm") nickel core material producing superior low-end response, phase angle response, and repeatability characteristics. The spring-tensioned 2-bolt gate in the core produces less variation in the magnetic characteristics as a result of repeated opening and closing of the gate. The mating surfaces where the gate closes the core are lapped for a near-perfect mating surface in order to minimize the impact on the magnetic characteristics caused by the necessity of having a break in the core.

Each split core CT is calibrated to linearise its response with the result that the defined accuracy for the M65x is maintained. The calibration of the split core CT is done to a specific phase on a specific M65x, and they are labelled with the serial number and phase of that M65x. It is essential that the CTs are connected to the phase of the M65x that is defined on the attached label if the accuracy specification is to be achieved.

The M65x supplied with split core CTs is fitted with terminals rather than the standard stud connections and the CT is supplied as standard with 8 ft leads which can be extended during installation, with restrictions.

Mounting brackets for the split core CTs are also available.

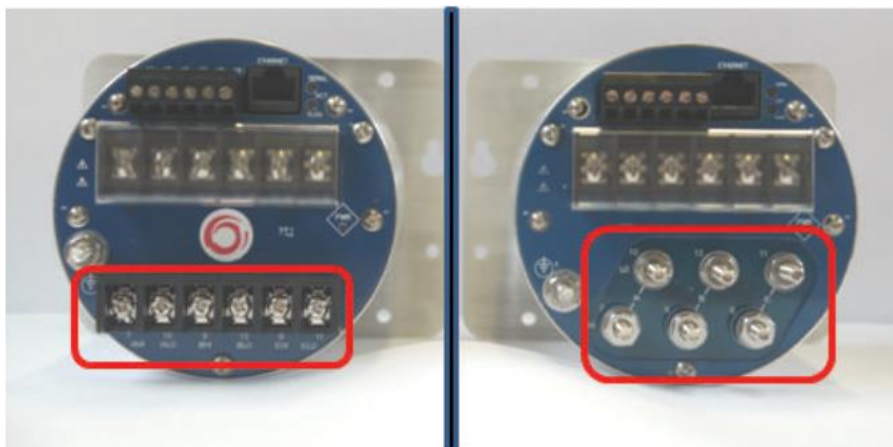
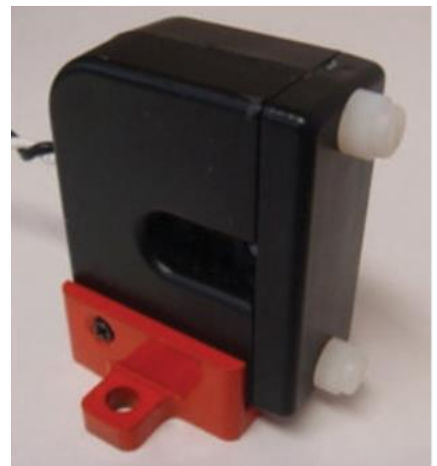
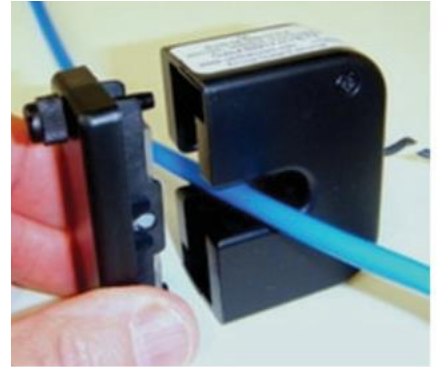

M651 built for split core option:  
 Connects to split cores CTs  
 0-10 mA into screw terminals

Conventional M651:  
 Connects to substation CTs  
 0-10 A+ into 6 x 10-32 studs

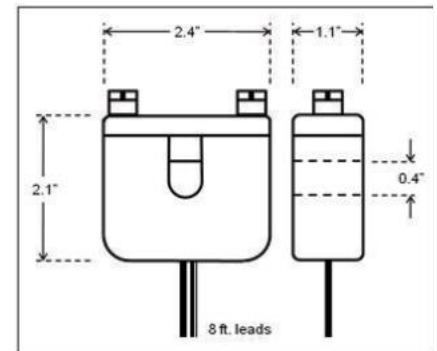

**DIMENSIONS**

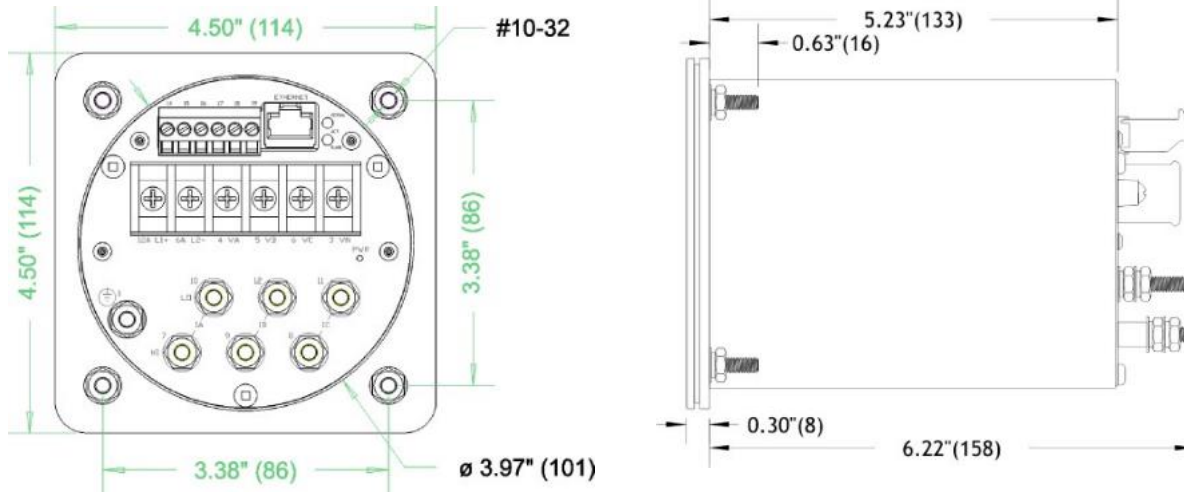

M650

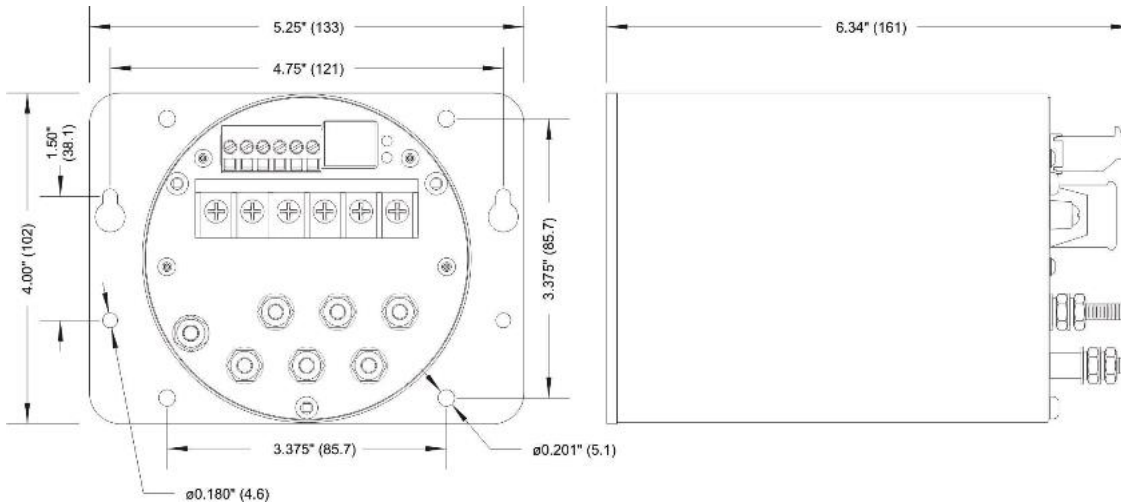

M651

For more information please contact  
 GE Grid Solutions

**Worldwide Contact Center**  
 Web: [www.GEGridSolutions.com/contact](http://www.GEGridSolutions.com/contact)  
 Phone: +44 (0) 1785 250 070

[www.GEGridSolutions.com](http://www.GEGridSolutions.com)

