



# MIW II

## DIRECTIONAL POWER PROTECTION SYSTEM

Numerical reverse, forward and low forward directional power and loss of field protection relay.

### KEY BENEFITS

- Reduce troubleshooting and maintenance cost - event recording, and analog/digital oscillography
- Design flexibility - Easy to use programming logic
- Access to information - Modbus RTU communications
- Configurable logic, curves, digital I/Os, and LEDs
- Flash memory for field upgrades
- Two settings groups
- Password protection for local operation
- Automatic display of last fault information
- AC/DC power supply
- Access via front panel keypad or communication links
- EnerVista™ compatible
- Isolated RS232 port

### APPLICATIONS

- Controlling power flow in AC generator applications

### FEATURES

#### Protection and Control

- Three power elements for MIW II 1000 and four power elements for MIW II 2000 (32\_x)
- Loss of field/excitation (40)
- Fuse failure (60)
- Configurable I/O
- 6 outputs, 4 configurable, plus trip and alarm

#### Monitoring and Metering

- Metering values for Ia, voltage values, P, Q, S, V<sub>1</sub>, V<sub>2</sub> and angle.
- 24-event record
- Analog/digital oscillography - 24 cycles at 8 samples per cycle
- Information displayed on last 5 relay trips

#### User Interfaces

- 2x16 character LCD display
- 6 LED indicators, 4 configurable in function and color
- Front RS232 and rear RS485 ports using ModBus RTU protocol up to 19,200 bps
- EnerVista™ software - an industry leading suite of software tools that simplifies every aspect of working with GE Multilin devices



## Overview

The MIW II, a member of the M II family of protection relays, is a microprocessor based relay that provides directional power and loss of field protection for generators. Operation is based on the calculated direction of the 3 phase power. At the same time, MIW II relays include a loss of field element (40), used to detect loss of excitation on synchronous generators. Severe reduction in excitation can cause generator heating, unstable operation, or even loss of synchronism. Modern excitation systems include minimum-excitation limiters to prevent under-excitation; with protective relays applied as backup protection.

MIW II relays are single phase but only one relay is required for three-phase applications, assuming there is balanced power flow.

Each protection element can be selectively enabled either via the front panel or via communications, and flexible settings enable accurate coordination with other devices.

## Protection

### Directional Power

Use the Directional Reverse FWD/REV Power to trip when the three-phase total power exceeds the pickup level in the reverse FWD/REV direction for a period of time. Set the pickup level in per unit of generator MW calculated from rated MVA and power factor. If required by

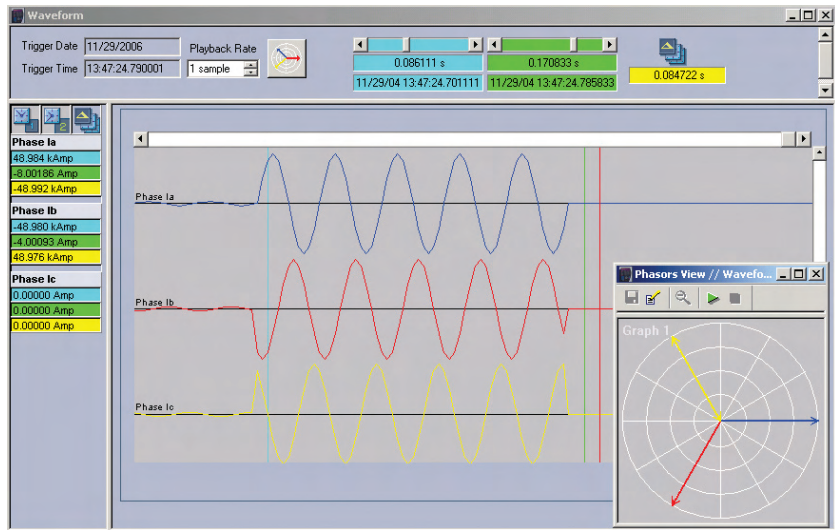

Use the oscillography feature as an accurate troubleshooting and diagnostics tool

the application, a time delay can be set to block the reverse power element for a given period of time.

### Loss of Excitation

Loss of excitation is detected via an impedance element. If the impedance falls within the impedance circle for the delay time specified, a trip will occur. Enable circle #1 and/or circle #2 to tune the protection feature to power system. Set the larger circle diameter equal to the synchronous reactance of the generator  $X_d$ , and the circle offset equal to the generator transient reactance  $X'd/2$ . This element will be blocked if there is a fuse failure condition or if the generator is offline.

### Fuse Failure

Use the VT Fuse Failure feature to issue an alarm and/or to block voltage driven protection functions that can operate incorrectly due to a partial or total voltage loss. This loss can be caused by the voltage transformers secondary circuit protection fuse failure. Different methods are used to detect the different types of VT fuse failure. The MIW II detects fuse failure under three possible situations:

- Breaker closed and positive sequence voltage (V1) level below an established value
- Very low positive sequence voltage with the presence of some positive sequence current,
- By comparing the ratio between the negative and positive voltage components ( $V2/V1$ ).

Any of the three previous conditions during a period longer than 80 ms, will activate the fuse feature.

### Multiple Setting Groups

Two separate settings groups are stored in MIW II non volatile memory, with only one group active at a given time. Switching between setting groups 1 and 2 can be done by means of a setting, a communication command or digital input activation.

Settings are divided in 2 categories; main and advanced settings. This allows users to have access to main relay

## Functional Block Diagram

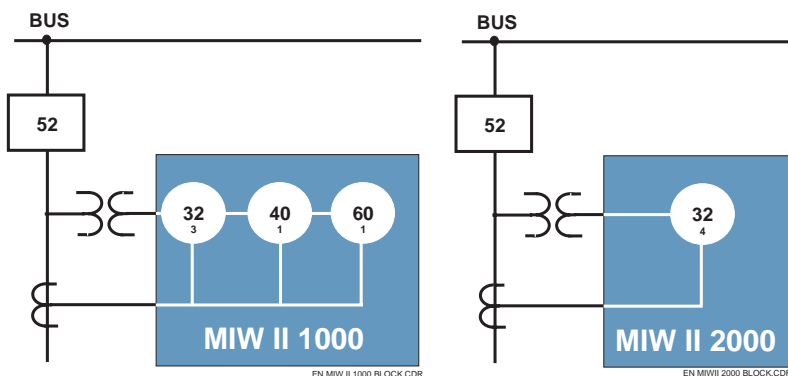

functionalities in an extremely user friendly way by entering only main settings, while having access to complete functionality for more complex use through advanced settings.

## Monitoring and Metering

The MIW II provides metering values for I1, voltage values, P, Q, S, V1, V2 and angle, with an accuracy of  $\pm 5\%$  in the complete range.

### Event Recording

Events consist of a broad range of change of state occurrences, including pickups, trips, contact operations, alarms and self test status. The MIW II stores up to 24 events time tagged to the nearest millisecond. This provides the information needed to determine sequence of events which facilitates diagnosis of relay operation. Each event is individually maskable in order to avoid the generation of undesired events, and includes the values of currents and voltages, and status of all the protection elements at the moment of the event.

### Oscillography

MIW II captures current waveforms and digital channels at 8 samples per cycle. One oscillography record with a maximum length of 24 cycles is stored in memory. Oscillography is triggered either by internal signals or an external contact.

### Configurable I/O and LEDs

Two digital inputs are user configurable. Out of the six digital outputs incorporated, two have a fixed function (trip and service required), while the other four are user programmable. Those configurable outputs can be assigned either to a set of pre-configured values, or an OR/NOT combination of the same values. Each configurable output can be independently latched, and individually selected as NO or NC by means of a jumper.

Outputs 1 and 2 can be isolated from outputs 2 and 3 by removing jumper JX. Four of the 6 LED indicators can also be programmed by the user. The first LED has a fixed assignment (relay in service), the second is fixed for trip, and the remaining four LEDs are configurable in function, memory and color (red or green).

### Configurable Logic

Up to a maximum of 4 configurable logic schemes can be implemented into the MIW II by means of using a set of 4 pre-configured logic gates and timer cells. A graphical user interface is provided for configuration of MIW II logic. The inputs of the MIW II configurable logic can be assigned to contact outputs and/or LEDs.

## User Interfaces

### Display

Measurement data (actual values), fault reports for the last five trips, and settings are shown on the 16x2 characters LCD display.

### Status LEDs

The MIW II incorporates 6 LED indicators in the front plate. The first one is a green LED identified as "READY", used to indicate the status of the protection elements. When "ON" it means the relay is energized and ready to protect, and at least one protection element has been enabled.

The second one is a red LED used for TRIP indication. It will be "ON" when a fault occurs and the relay energizes the trip outputs. Once energized, it will remain latched until the ESC/RESET key is pressed for three seconds to RESET the relay.

Four additional LEDs are programmable in function and color. The factory default functions of the programmable LEDs are: Phase Trip, Ground Trip, 50 Trip, and Pickup, while the color is set to RED, and the status memory as self-resetting. The user may change the function and status memory through the use of the EnerVista™ software.

The LED color can be modified using the relay keypad. The status memory may be programmed as either self-resetting or latching. If programmed as self-resetting, when the associated function drops out the corresponding LEDs turn off. If programmed as latched, the LED will remain "ON" until the ESC/RESET key is pressed for three seconds to reset the relay.

In order to test LEDs, pressing the ESC/RESET key for three seconds will turn "ON" all LEDs. When the key is released, the LEDs will turn off (except if the function pickups are still active). This allows easy testing of the equipment.

### Keypad

A five-button keypad allows user access for easy relay interrogation and change of settings. Access to events and oscillography records, and unit configuration is possible only through PC communication.

### Self-Test Diagnostics

Comprehensive self-test diagnostics occur at power up and occur continuously during relay operation. Any problem found by self-tests causes an alarm and an event is logged.

### Communication Ports

A front mounted RS232 and a rear RS485 port allow easy user interface via a PC. ModBus® RTU protocol is used for all ports. The relay supports baud rates from 300 to 19,200 bps. Up to 32 GE Multilin devices can be addressed on a single communications channel. A unique address must be assigned to each relay via a setting when multiple relays are connected.

### MultiNet™ compatible

MultiNet is a communications module that provides GE Multilin serial ModBus IEDs with ModBus TCP/IP communications over Ethernet, allowing connection to fiber optic LAN and WAN network systems.

MultiNet has the capability to connect up to 32 serial ModBus devices eliminating complex wiring and additional communications converters, and providing a streamlined and economical Ethernet hub. Unlike most communications converters that are designed for commercial use, MultiNet is environmentally hardened to withstand severe utility and industrial conditions.

- Converts Modbus RTU over RS485 into Modbus TCP/IP over Ethernet
- Supports both 10BaseT and 10BaseF fiber connections
- Connect up to 32 RS485 serial devices to an Ethernet network
- Modbus TCP/IP provides multiple SCADA masters allowing simultaneous communications to the same IED
- Flexible mounting options allow retrofit to existing devices
- Industrially hardened for utility and industrial applications
- Simple "plug & play" device setup with™ software

MultiNet gives you the ability to connect M II serial devices to new or existing Ethernet networks. It has a 10Base-F fiber optic interface that provides high EMI/RFI immunity and inherent electrical isolation over long cable runs. MultiNet setup is simple, with a Windows-based EnerVista™ software program for installing and configuring the communication drivers.

### EnerVista™ Software

The EnerVista™ Suite is an industry-leading set of software programs that simplifies every aspect of using the relay. The EnerVista™ suite provides all the tools to monitor the status of the protected asset, maintain the relay, and integrate information measured into DCS or SCADA monitoring systems. Convenient waveform and Sequence of Events viewers are an integral part of the MII Setup software included with every MIW II relay, to carry out postmortem event analysis to ensure proper protection system operation.

### EnerVista™ Launchpad

EnerVista™ Launchpad is a powerful software package that provides users with all of the setup and support tools needed for configuring and maintaining GE Multilin products. The setup software within Launchpad allows configuring devices in real-time by communicating using serial, Ethernet, or modem connections, or offline by creating setting files to be sent to devices at a later time.

Included in Launchpad is a document archiving and management system that ensures critical documentation is up-to-date and available when needed. Documents made available include:

- Manuals
- Application Notes
- Guideform Specifications
- Brochures
- Wiring Diagrams
- FAQs
- Service Bulletins

### Viewpoint Monitoring

Viewpoint Monitoring is a simple-to-use and full-featured monitoring and data recording software package for small systems. Viewpoint Monitoring provides a complete HMI package with the following functionality:

- Plug-&-Play Device Monitoring
- System Single-Line Monitoring & Control
- Annunciator Alarm Screens
- Trending Reports
- Automatic Event Retrieval
- Automatic Waveform Retrieval



Connect up to 32 ModBus devices to your ethernet network including M II devices

### User Interface

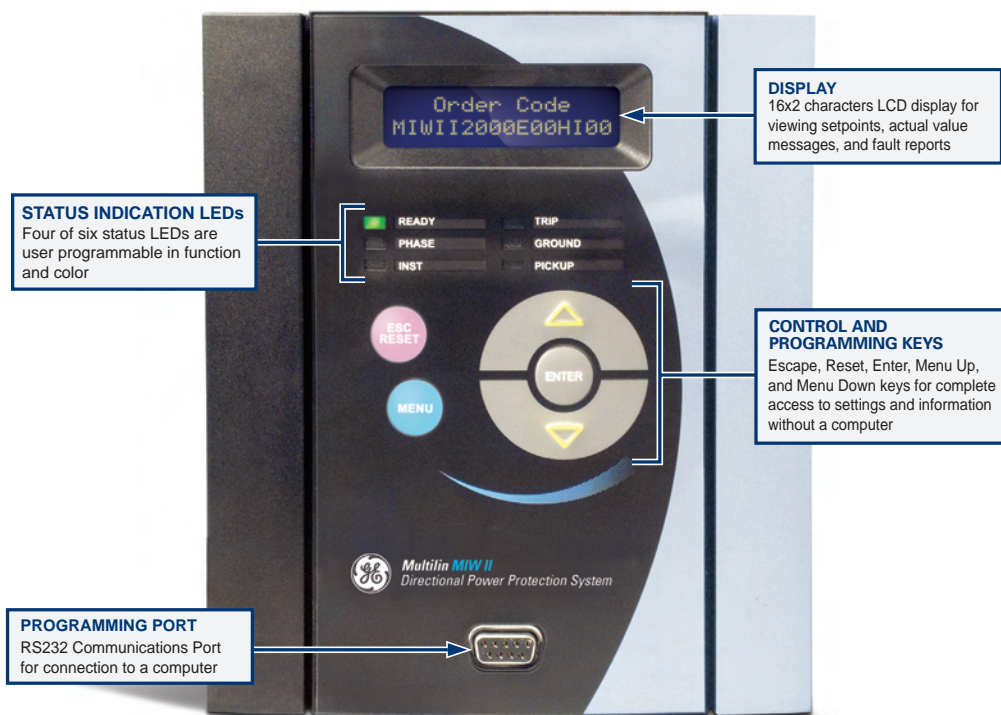

**STATUS INDICATION LEDs**  
Four of six status LEDs are user programmable in function and color

**DISPLAY**  
16x2 characters LCD display for viewing setpoints, actual value messages, and fault reports

**CONTROL AND PROGRAMMING KEYS**  
Escape, Reset, Enter, Menu Up, and Menu Down keys for complete access to settings and information without a computer

**PROGRAMMING PORT**  
RS232 Communications Port for connection to a computer



## Dimensions

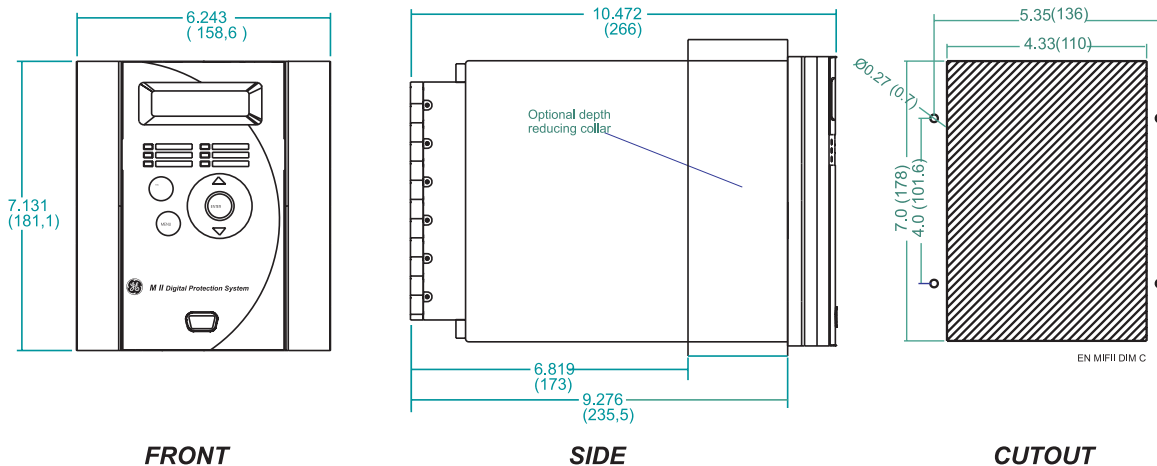

\* Note: Dimensions in inches (mm)

## Typical Wiring

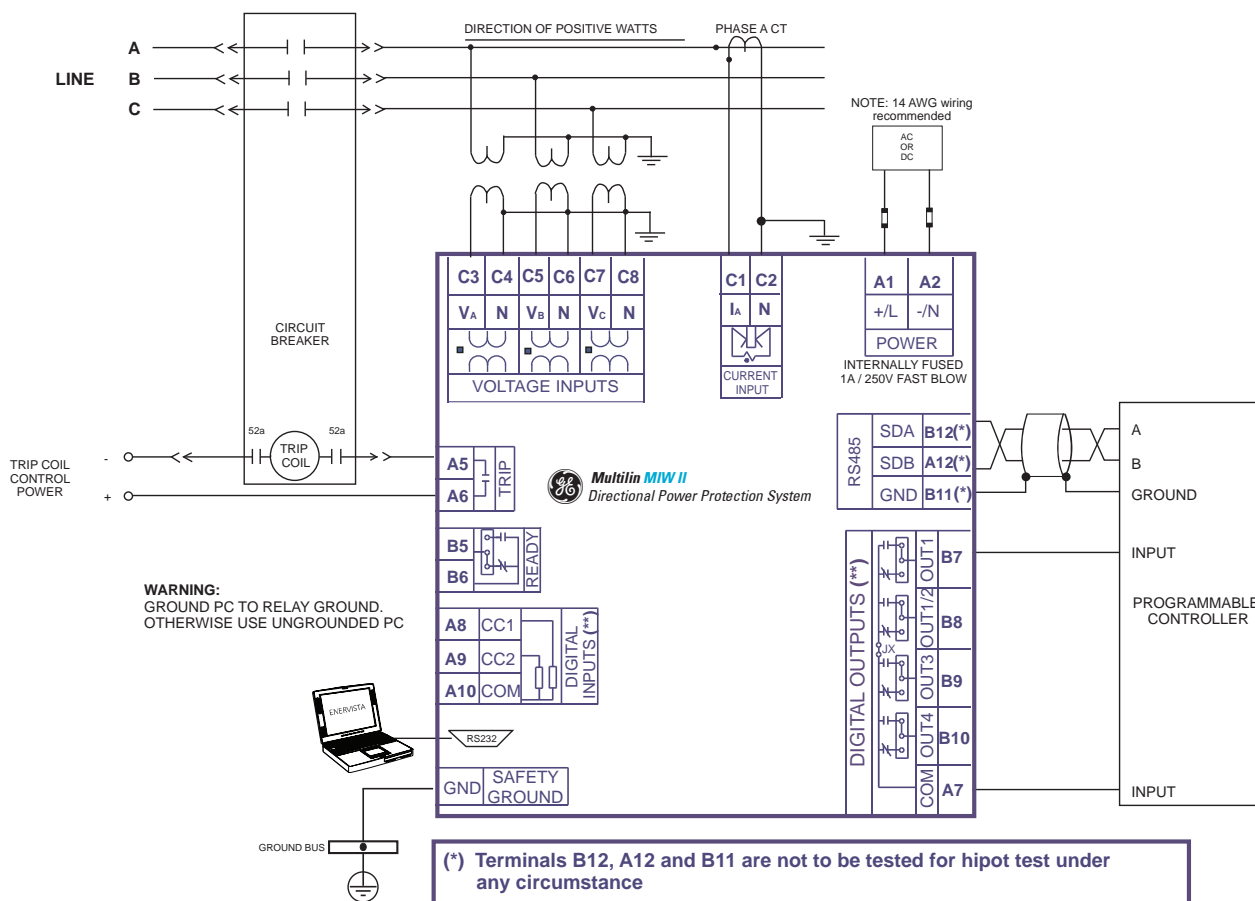

## Technical Specifications

### PROTECTION

#### UNIVERSAL POWER UNIT

**Pickup level:** 0.01-1.5 per unit in steps of 0.01  
**Accuracy of primary magnitudes:** 5% in the complete range  
**Time delay (one for alarm and another for trip):** 0.2 to 120s in steps of 0.1 seconds  
**Timer accuracy:** 5% of the operation time or 30s (whichever is greater) for magnitude > 1.5 times the pickup level

#### LOSS OF FIELD UNITS (40-1 AND 40-2) (40)

**Current, Voltage:** Fundamental  
**Pickup level (two Mho units):** 1-300 Ohm per unit in steps of 0.10Ohm  
**Drop out level:** 97-98% of the pickup level  
**Accuracy of primary magnitudes:** 5% in the complete range  
 5° in metering of the angle between voltage and current  
**Reset type:** Instantaneous  
**Timer accuracy:** 5% of the operation time or 30ms (whichever is greater) for magnitude > 1.5 times the pickup level

### INPUTS

#### AC CURRENT

**Secondary Rated Current:** 5A  
**Frequency:** 50 / 60 Hz ±3 Hz (The unit can be set to 50 or 60 Hz)  
**Relay Burden:** < 0.2 VA @ In = 5A secondary  
**Current Withstand:** 4 x In continuously  
 100 x In for 1 sec

#### AC VOLTAGE High Range

**Secondary Rated Voltage:** 110/120V  
**Frequency:** 50 / 60 Hz ±3 Hz (The unit can be set to 50 or 60 Hz)  
**Relay Burden:** < 0.2 VA @ 120 VAC  
**Voltage Withstand:** 440 VAC continuously

#### AC VOLTAGE Low Range

**Secondary Rated Voltage:** 20-60 VAC  
**Frequency:** 50 / 60 Hz ±3 Hz (The unit can be set to 50 or 60 Hz)  
**Relay Burden:** < 0.2 VA @ 120 VAC  
**Voltage Withstand:** 250 VAC continuously

#### DIGITAL INPUTS High Range

**Voltage Threshold:** 75 VDC  
**Maximum Voltage:** 300 VDC  
**Relay Burden:** 5 mA @ 300 VDC

#### DIGITAL INPUTS Low Range

**Voltage Threshold:** 12 VDC  
**Maximum Voltage:** 57 VDC  
**Relay Burden:** 2 mA @ 57 VDC

### METERING

#### FUNDAMENTAL CURRENT

**Accuracy:** ±5% in the complete range

### MONITORING

#### OSCILLOGRAPHY

**Records:** 1 x 24 cycles  
**Sampling rate:** 8 samples per power frequency cycle  
**Triggers:** Any element pickup or operation  
 Digital input configured as oscillography trigger  
 Communications command  
 AC input channels  
 Digital input/output channels  
 Self-test events

**Information:** AC input channels  
 Digital input/output channels  
 Self-test events

#### EVENT RECORDER

**Capacity:** 24 events  
**Time-tag:** To 1 millisecond  
**Triggers:** Any element pickup, operation or reset  
 Digital input/output change of state  
 Self-test events

### POWER SUPPLY

#### LOW RANGE

**Rated DC Voltage:** 24 to 48 VDC  
**Min./Max. DC Voltage:** 19 / 58 VDC

#### HIGH RANGE

**Rated DC Voltage:** 110 to 250 VDC  
**Min./Max. DC Voltage:** 88 / 300 VDC  
**Rated AC Voltage:** 110 to 230 VAC @ 48 - 62 Hz  
**Min./Max. AV Voltage:** 88 / 264 VAC @ 48 - 62 Hz

**Power Consumption:** Max. = 10 W  
**Backup time:** (date, time and log memory) without power supply voltage >1 week

### COMMUNICATIONS

**Local Communication:** 2x16 LCD Display  
 5 button frontal keypad

**Remote Communication: (local or remote PC and communications net):**  
**Mode:** ModBus® RTU  
**Baud rate:** 300 to 19200 bps  
 DB9 connector for RS232 ports on the front (1) and RS485 on the rear

### OUTPUTS

#### TRIPPING CONTACTS

**Contact capacity:**  
**Max. Operating Voltage:** 400 VAC  
**Continuous current:** 16 A  
**Make and Carry:** 48 A  
**Breaking:** 4000 VA

#### OUTPUT RELAYS

**Configuration:** 6 electromechanical, form C  
**Contact Material:** Silver alloy suited for inductive loads

**Operating time:** 8 ms

#### MAXIMUM RATINGS FOR 100,000 OPERATIONS

	Voltage	Make/Carry		Break	MAX LOAD
		Continuous	0.2 SEC		
DC Resistive	24 VDC	16A	48A	16A	384W
	48 VDC	16A	48A	2.6 A	125W
	25 VDC	16A	48A	0.6 A	75W
	250 VDC	16A	48A	0.5 A	125 W
AC Resist	120 VAC	16A	48A	16 A	1920 VA
	250 VAC	16A	48A	16 A	4000 VA
AC Induct.	250 VAC	10A	30A	10 A	1000 VA

### MECHANICAL CHARACTERISTICS

• Metallic package in 1/4 19" rack and 4 units high  
 • Protection class IP52 (according to IEC 529)

### ENVIRONMENTAL

**Temperature:**  
**Storage:** -40°C to +80°C  
**Operation:** -20°C to +60°C  
**Humidity:** Up to 95% without condensing  
**Pollution Degree:** 2

### PACKAGING

**Approximate Weight:**  
**Net:** 8.8 lbs (4 kgs)  
**Ship:** 9.9 lbs (4.5 kgs)

### TYPE TESTS

TEST	STANDARD	CLASS
<b>Insulation Test Voltage:</b>	IEC 60255-5	2kV, 50/60Hz 1min
<b>Surge Test Voltage:</b>	IEC 60255-5	5 kV, 0.5 J. (3 positive pulses and 3 negative.)
<b>1 MHz Interference:</b>	IEC 60255-22-1	III
<b>Electrostatic Discharge:</b>	IEC 60255-22-2 EN 61000-4-2	IV 8 kV in contact, 15 kV through air
<b>Radio interference:</b>	IEC 60255-22-3: 40 MHz, 151 MHz, 450 MHz and cellular phone	III
<b>Radiated Electromagnetic fields with amplitude modulation.</b>	ENV 50140	10 V/m
<b>Radiated Electromagnetic fields with amplitude modulation. Common mode.</b>	ENV 50141	10 V/m
<b>Radiated Electromagnetic fields with frequency modulation.</b>	ENV 50204	10 V/m
<b>Fast Transients:</b>	ANSI/IEEE C37.90.1 IEC 60255-22-4 BS EN 61000-4-4	IV IV IV
<b>Magnetic fields at industrial frequency:</b>	EN 61000-4-8	30 AV/m
<b>Power Supply interruptions:</b>	IEC 60255-11 IEC 57 (CO) 22 EN 55011	B
<b>Temperature:</b>	IEC 60255-21-2	II
<b>RF Emission:</b>	EN 55011	I
<b>Sinusoidal Vibration:</b>	IEC 60255-21-1	II
<b>Shock:</b>	IEC 60255-21-2	I
<b>Insulation Test:</b>	IEC255-5 (Tested on CTs, Power Supply terminals, Contact Inputs and Contact Outputs)	

## Ordering

MIW II	*	0	0	0	E	0	0	0	0	0	0	Description
Protection Elements:	1											3 x Directional Power, 1 x Loss of field, 1 x Fuse Failure
	2											4 x Directional Power
Power Supply										LO		24-48 VDC (Range: 19-58 VDC)
										HI		110-250 VDC (Range: 88-300 VDC)
												110-230 VAC (Range: 88-264 VAC)

Visit [www.GEMtilin.com/MIWII](http://www.GEMtilin.com/MIWII) to:



- View Guideform specifications
- Download the instruction manual
- Review applications notes and support documents
- Buy a MIW II online
- View the MIW II brochure