

PQM/PPQM

Power Quality Meter



Continuous metering of three-phase systems.

Features and Benefits

- Standard and portable options
- Power quality analysis
- Flexible control for demand load shedding, power factor, etc.
- Programmable setpoints
- Four assignable output relays
- Four switch inputs
- Process variable measurement using analog input
- PC connectivity
- Allows for calculation of harmonic distribution
- Communicates with GE Multilin 269 (MOD 508)

Applications

- Continuous metering of distribution feeders, transformers, capacitor banks, generators and motors
- Medium and low voltage systems
- enerVista.com compatible (see page 275)

Protection and Control

- Basic alarm on overcurrent, undercurrent or voltage unbalance

Monitoring and Metering

- Current, voltage, real and reactive power, energy use, cost of power, power factor and frequency
- Harmonic analysis

User Interfaces

- Select URPC functionality
- RS232 and RS485 ports



Standard Features

The PQM is a digital metering device that provides continuous monitoring of a three-phase system. It provides metering of current, voltage, real and reactive power, energy use, cost of power, power factor and frequency.

When portable monitoring of a three-phase system is required, a Portable PQM is the ideal choice. This version offers the same features as the panel mount PQM in a rugged carrying case. The PPQM additionally acts as a power management tool, a troubleshooting tool and a data collection device.

In either form, the PQM can provide users with advanced features for monitoring and metering which include:

Mounting Versatility

The panel mount with display offers an easy local interface. Standard models have RS485 ModBus® communications for programming and monitoring. Users can replace expensive additional devices by adding the CONTROL, TRANSDUCER and POWER analysis options to the PQM as required.

Metering

Each voltage and current is sampled 64 times per cycle for 0.2% accuracy true RMS True RMS or displacement (fundamental) quantities.

- $I_a I_b I_c I_n$
- $V_a V_b V_c V_{ab} V_{bc} V_{ca}$
- V I unbalance
- True PF crest and K factor
- Hz W var VA
- Wh varh VAh W cost
- Demand: A W var VA

A keypad and illuminated 40 character display provide local setpoint setting and monitoring values and status.

Alarms

Any of the assignable outputs may be used to trigger an alarm

for specific applications. Simple alarm messages provide easy notification.

CONDITION	APPLICATION
overcurrent	motors/transformers
undercurrent	pumps/compressors
neutral current	leakage/unbalance
current unbalance	motors
overvoltage	equipment protection
undervoltage	motors/load transfer
phase sequence	pumps/equipment
overfrequency	generators
underfrequency	load shedding
power factor	capacitor banks
switch input	process control

Communications

Integrate process, instrumentation and electrical requirements in a plant automation system by connecting PQM meters together to a DCS or SCADA system. A computer running PQMPC can change system setpoints, monitor values, status and alarms. Continuous monitoring minimizes process downtime by immediately identifying potential problems due to faults or changes from growth.

- RS485 ModBus® 1,200 to 19,200 bps
- Mini RTU SCADA system component
- Measure actual values
- Read status
- Issue control commands
- Load all setpoints from a file
- Change individual setpoints

The standard version PQM comes complete with a front RS232 port which can be used for data collection, printing reports or problem analysis without disturbing the main communication interface to rear RS485 port.

Future Expansion

The PQM uses non-volatile flash memory for firmware storage. This allows future product upgrades to be loaded via the serial port. Upgrades can also be accessed from www.geindustrial.com/Multilin.

Initially PQM meters can be used as stand-alone units. Open architecture allows connection to other or ModBus®-compatible devices on the same communication link. These can be integrated in a complete plant wide system for overall process monitoring and control.

Options

There are a variety of options available to the user, allowing a range of custom configurations:

Transducer

Four Analog Outputs: four isolated analog outputs can be used to replace eight analog transducers. Output signals can be selected from any of the measured parameters for direct interface to a PLC.

Analog Input: with the analog input and an output relay for selection, two transducers (such as temperature or water level) can be monitored and used for control.

Connect two 4 to 20 mA transducers for process variable measurement and control.

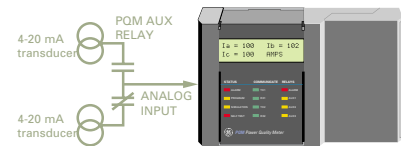

Second Rear Comm Port: an additional rear RS485 comm port is provided for simultaneous monitoring by process, instrument, electrical or maintenance personnel.

Redundancy in high security systems is provided by the 2nd RS485 comm port.

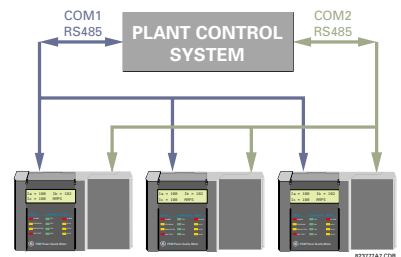

Control

Three Output Relays and Four Inputs: measured parameters from the standard PQM can be combined with setpoints and I/Os for control applications. With the control option, three output relays and four switch inputs are added along with programmable setpoints to make a mini RTU. Output relays can also be controlled via the communication port or assigned to different setpoints for custom programming to accommodate many situations. Possibilities include:

- Undercurrent alarm for pumps
- Over and undervoltage for generators
- Unbalance alarm for rotating machines
- Dual level power factor for capacitor bank switching
- Underfrequency/demand output for load shedding resulting in power cost savings
- kWh, kvarh and kVAh pulse output for PLC interface

Power factor setpoints and two output relays can be used for two-level capacitor bank switching.

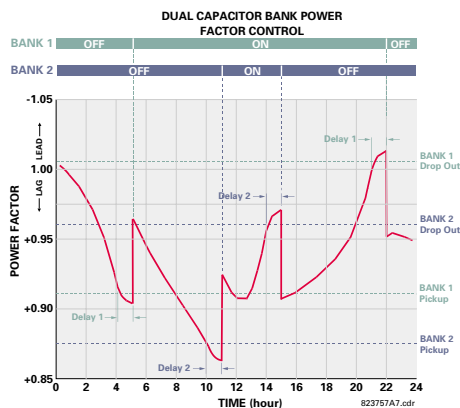

Power Analysis

Data Logger (Trending): trending is useful as a troubleshooting aid when a problem is detected. Measured values can be selected and plotted with a programmable sampling rate to suit the time interval of interest. The generated chart recorder screen can be printed or exported to other programs for report writing.

Record trends of measured parameters over time.

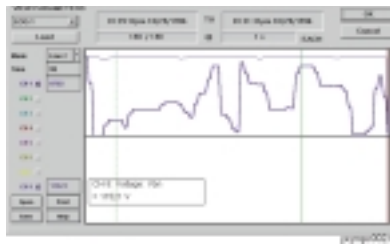

Harmonic Analysis: non linear loads such as variable speed drives, computers and electronic ballasts can cause harmonics which may lead to problems such as nuisance breaker tripping, telephone interference, transformer, capacitor or motor overheating. For fault diagnosis such as detecting undersized neutral wiring, need for a harmonic rated transformer, or effectiveness of harmonic filters, details of the harmonic spectrum are useful and available with the power analysis option.

Harmonic spectrum analysis can identify problems and ensures implemented changes work correctly.

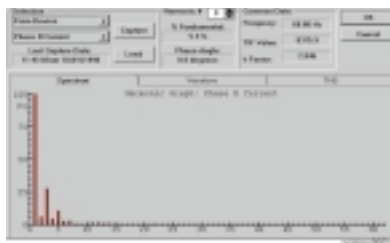

Waveform Capture: voltage and current waveforms can be captured and displayed on a PC using the PQMPC program supplied with the PQM or using third party software. Distorted peaks or notches from SCR switching provide clues for taking corrective action.

Voltage and current waveforms provide valuable insights into system problems.

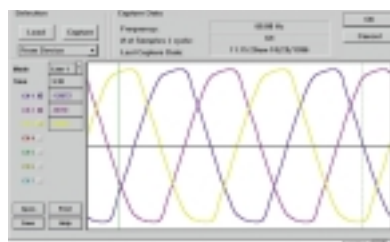

Event Recorder: alarms, setpoint triggers, input and output events can be stored in a 40 event record and time and date stamped by the internal clock. This is useful for diagnosing problems and system activity. Minimum and maximum values are also continuously updated and time stamped.

Trace Memory: the PQM can be configured to record a maximum of 36 cycles of data on all voltage and current inputs based on overvoltage, undervoltage, overcurrent or switch input state change.

Software

PQMPC Program

PQMPC is a Windows®-based program that can be used to enter setpoints, read metered values, monitor status and evaluate power quality. All data continuously gathered by the PQM can be transferred to a third party software program for display, control or analysis via the communications interface.

Once all setpoints have been entered they can be downloaded into any PQM or stored in a file with a tag name for later reference. Screens are available for monitoring all measured values such as current, voltage, or power. Status of alarms and control settings can also be displayed.

Voltage and current waveshape can give important information about what is happening on a system. For example, non linear loads such as computers or variable speed drives may introduce distortion that indicates filtering is required.

Gain useful system information using voltage/current waveform capture.

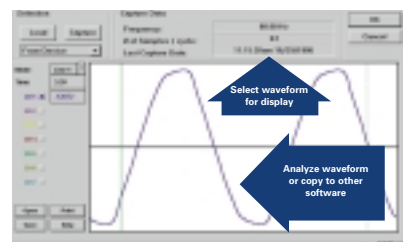

Typical Wiring

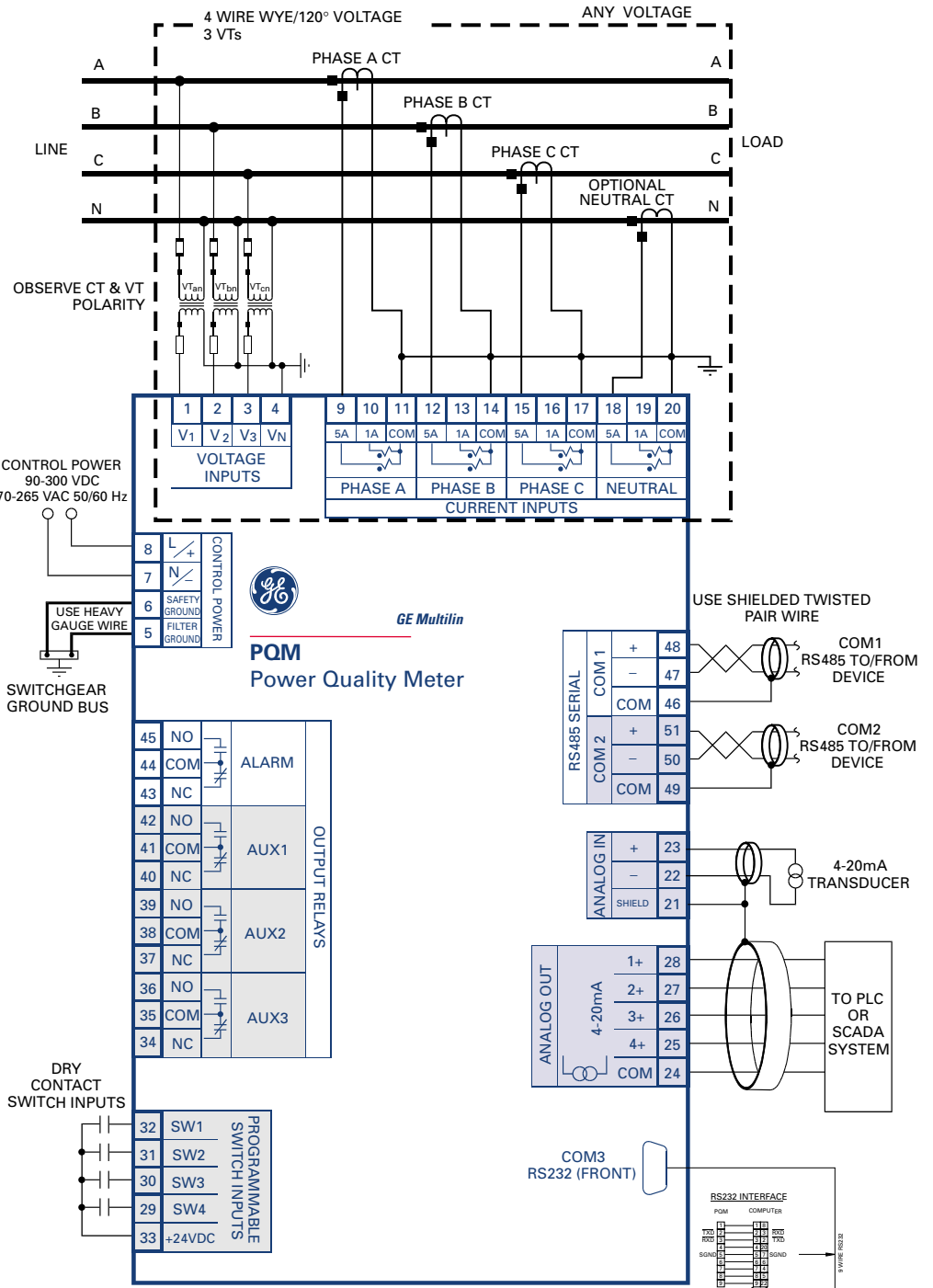
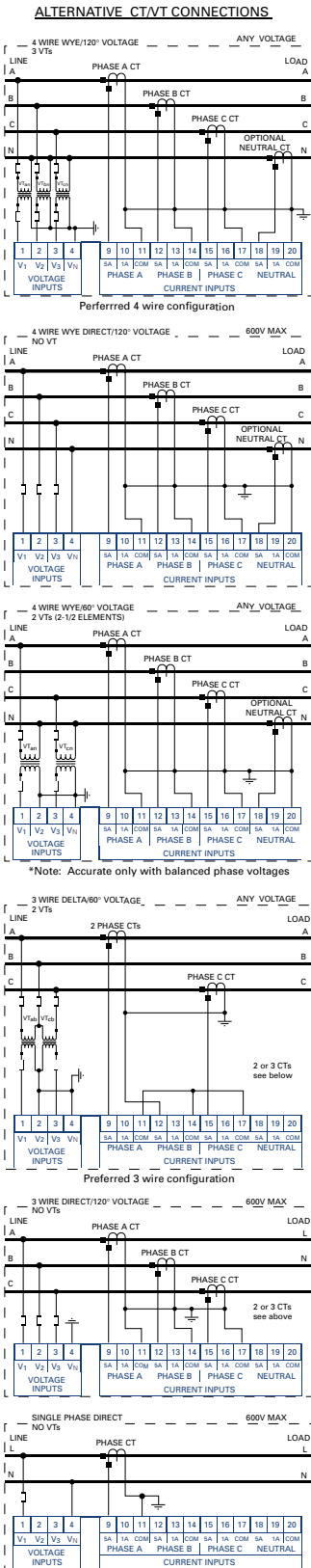

- NOTES:**
- Relay contact state shown with control power not applied.

CAUTION: USE HRC FUSES FOR VT PRIMARY TO ENSURE ADEQUATE INTERRUPTING CAPACITY.

- Transducer Option
- Control Option

823807AS.CDR
823753AQ.DWG

Harmonic analysis can provide early warning of problems, helping to prevent equipment damage or nuisance breaker tripping.

PQMPC enables waveform capture information to be transferred to other programs for inclusion in reports and printouts. Routine event logs of demand or sampled voltage can also be created and printed out.

To verify correct installation, the simulation mode substitutes programmed currents and voltages for real ones. This powerful tool is also an excellent training aid for plant personnel.

URPC Program

The Windows®-based URPC program allows the user to create single line diagrams for substa-

tion and system monitoring schemes. Additionally, annunciator panel viewing, metering, and settings changes can also be performed using the program. With the URPC program the user can access multiple PQMs or different devices for metering in real time. The program may be used locally through the RS232 serial port or remotely through the other ports on the device.

PQM Technical Specifications

MONITORING			
UNDERVOLTAGE MONITORING			
Required voltage:	20 V applied		
Pickup level:	0.50 – 0.99 in steps of 0.01 x VT		
Dropout level:	103% of pickup		
Time delay:	0.5 – 600.0 in steps of 0.5 sec		
Phases:	Any one/any two/all three (programmable) phases have to exceed pickup to operate		
Level accuracy:	Per voltage input		
Timing accuracy:	-0/+1 sec		
OVERVOLTAGE MONITORING			
Pickup level:	1.01 – 1.25 in steps of 0.01 x VT		
Dropout level:	97% of pickup		
Time delay:	0.5 – 600.0 in steps of 0.5 sec		
Phases:	Any one/any two/all three (programmable) phases have to exceed pickup to operate		
Level accuracy:	Per voltage input		
Timing accuracy:	-0/+1 sec		
UNDERFREQUENCY MONITORING			
Required voltage:	20 V applied		
Pickup level:	20 – 70.00 in steps of 0.01 Hz		
Dropout level:	Pickup +0.03 Hz		
Time delay:	0.1 – 10.0 in steps of 0.1 sec		
Level accuracy:	±0.02 Hz		
Timing accuracy:	±3 cycles		
OVERFREQUENCY MONITORING			
Required voltage:	20 V applied		
Pickup level:	20 – 70.00 in steps of 0.01 Hz		
Dropout level:	Pickup -0.03 Hz		
Time delay:	0.1 – 10.0 in steps of 0.1 sec		
Level accuracy:	±0.02 Hz		
Timing accuracy:	±3 cycles		
POWER FACTOR MONITORING			
Required voltage:	20 V applied		
Pickup level:	0.50 lag – 0.50 lead in steps of 0.01		
Dropout level:	0.50 lag – 0.50 lead in steps of 0.01		
Time delay:	0.5 – 600.0 in steps of 0.5 sec		
Timing accuracy:	-0/+1 sec		
SAMPLING MODES			
	SAMPLES/ CYCLE	INPUTS SAMPLED AT A TIME	DURATION (CYCLES)
Metered values	64	ALL	2
Trace memory	16	ALL	continuous
Harmonic spectrum	256	1	1
DEMAND MONITORING			
Measured values:	Phase A/B/C/N current (A) 3 ϕ real power (kW) 3 ϕ reactive power (kvar) 3 ϕ apparent power (kVA)		
Measurement type:	Thermal exponential 90% response time (programmable): 5 – 60 min, steps of 1 min Block interval/rolling demand time in interval (programmable): 5 – 60 min, steps of 1 min		
Pickup level:	A: 10 – 7,500 in steps of 1 kW: 0.1 – 6,500.0 in steps of 0.1 kvar: 0.1 – 6,500.0 in steps of 0.1 kVA: 0.1 – 6,500.0 in steps of 0.1		
POWER SUPPLY			
CONTROL POWER			
Input:	90 – 300 VDC 70 – 285 VAC 50/60 Hz		
Power:	10 VA nominal, 20 VA maximum		
Holdup:	100 ms typical @ 120 VAC/VDC		

METERING			
MEASURED VALUES			
PARAMETER	ACCURACY (% of full scale)	RESOLUTION	RANGE
Voltage	±0.2%	1 VOLT	20% of VT – 100% of VT
Current	±0.2%	1 A	1% of CT – 150% of CT
Voltage unbalance	±1%	0.1%	0 – 100.0%
Current unbalance	±1%	0.1%	0 – 100.0%
kW	±0.4%	0.01 kW	0 – 999,999.99 kW
kvar	±0.4%	0.01 kvar	0 – 999,999.99 kvar
kVA	±0.4%	0.01 kVA	0 – 999,999.99 kVA
kWh	±0.4%	1 kWh	2 ³² kWh
kvarh	±0.4%	1 kvarh	2 ³² kvarh
kVAh	±0.4%	1 kVAh	2 ³² kVAh
Power factor	±1%	0.01	±0.0 – 1.0
Frequency	±0.02 Hz	0.01 Hz	20.00 – 70.00 Hz
kw demand	±0.4%	0.1 kW	999,999.99 kW
kvar demand	±0.4%	0.1 kvar	999,999.99 kvar
kva demand	±0.4%	0.1 kva	999,999.99 kva
Amps demand	±0.2%	1 A	0 – 7,500 A
Amps THD	±2.0%	0.1%	0.0 – 100.0%
Volts THD	±2.0%	0.1%	0.0 – 100.0%
Crest factor	±0.4%	—	1 – 9.99

INPUTS	
AC CURRENT	
Conversion:	True RMS, 64 samples/cycle
CT input:	1 A and 5 A secondary
Burden:	0.2 VA
Overload:	20 x CT for 1 sec 100 x CT for 0.2 sec
Full scale:	150% of CT
Frequency:	up to 32nd harmonic
Accuracy:	±0.2% of full scale, true RMS
AC VOLTAGE	
Conversion:	True RMS, 64 samples/cycle
VT pri/sec:	Direct or 120 – 72,000 : 69 – 240
Input range:	20 – 600 VAC
Full scale:	150/600 VAC autoscaled
Burden:	<0.1 VA
Frequency:	up to 32nd harmonic
Accuracy:	±0.2% of full scale, true RMS
SWITCH INPUTS	
Type:	Dry contact
Resistance:	1,000 Ω max ON resistance
Voltage:	24 VDC @ 2 mA
Duration:	100 ms minimum
ANALOG INPUT	
Range:	4 – 20 mA
Accuracy:	±1% of full scale
Relay output:	Programmable 4 – 20 mA
Internal burden resistance:	250 Ω
PULSE INPUT	
Max inputs:	4
Min pulse width:	150 ms
Min off time:	200 ms

COMMUNICATIONS	
COM1/COM2 type:	RS485 2-wire, half duplex, isolated
COM3 type:	RS232, 9PIN
Baud rate:	1,200 – 19,200 bps
Protocol:	ModBus® RTU
Functions:	Read/write setpoints Read actual values Execute commands

*Specifications subject to change without notice.

OUTPUTS			
ANALOG OUTPUTS			
Accuracy:	±1% of full scale reading		
	OUTPUT		
	0 – 1 mA (T1 Option)	0 – 20 mA and 4 – 20 mA (T20 Option)	
Max load	2400 Ω	600 Ω	
Max output	1.1 mA	21 mA	
Isolation:	50 V isolated, active source		
OUTPUT RELAYS			
Voltage	Make/Carry Continuous	Make/Carry 0.2 SEC	Break
Resistive	30 VDC	5	30
	125 VDC	5	30
	250 VDC	5	30
Inductive (Vr = 7ms)	30 VDC	5	30
	125 VDC	5	30
	250 VDC	5	30
Resistive	120 VAC	5	30
	250 VAC	5	30
	120 VAC	5	30
Inductive PF = 0.4	250 VAC	5	30
	250 VAC	5	30
Configuration	FORM C NO/NC		
Contact material	SILVER ALLOY		
PULSE OUTPUT			
Parameters:	+ve kWh, -ve kWh, +ve kvarh, -ve kvarh, kVAh		
Interval:	1 – 65000 in steps of 1		
Pulse width:	100 – 2000 ms in steps of 10 ms		
Min pulse interval:	500 ms		
ENVIRONMENTAL			
Humidity:	95% non-condensing		
Temperature:	-10° C to +60° C ambient		
Environment:	IEC 68-2-38 temperature/humidity cycle		
PACKAGING			
Shipping box:	8 1/2" L x 6" H x 6" D (215 mm x 152 mm x 152 mm)		
Ship weight:	5 lbs (2.3 kg)		
NOTE:	LCD contrast impaired below -20° C		
TYPE TESTS			
Dielectric strength:	2.0 kV for 1 min to relays, CTs, VTs, power supply		
Insulation resistance:	IEC255-5 500 VDC		
Transients:	ANSI C37.90.1 oscillator 2.5 kV/1 MHz ANSI C37.90.1 fast rise ANSI C37.90.1 fast rise Ontario Hydro A-28M-82 IEC255-4 impulse/high frequency disturbance Class III Level		
Impulse test:	IEC 255-5 0.5 J 5 kV		
RFI:	50 MHz/15 W transmitter		
EMI:	C37.90.2 electromagnetic interference @ 150 MHz and 450 MHz, 10 V/m		
Static:	IEC 801-2 static discharge		
Note: Type test report available upon request.			
APPROVALS			
ISO:	Manufactured to an ISO9001 registered program		
UL:	Recognized under E83849		
CSA:	Recognized under LR41286		
CE:	Conforms to EN 55011/CISPR 11, EN 50082-2 Conforms to IEC 947-1, IEC 1010-1		

PQM Dimensions

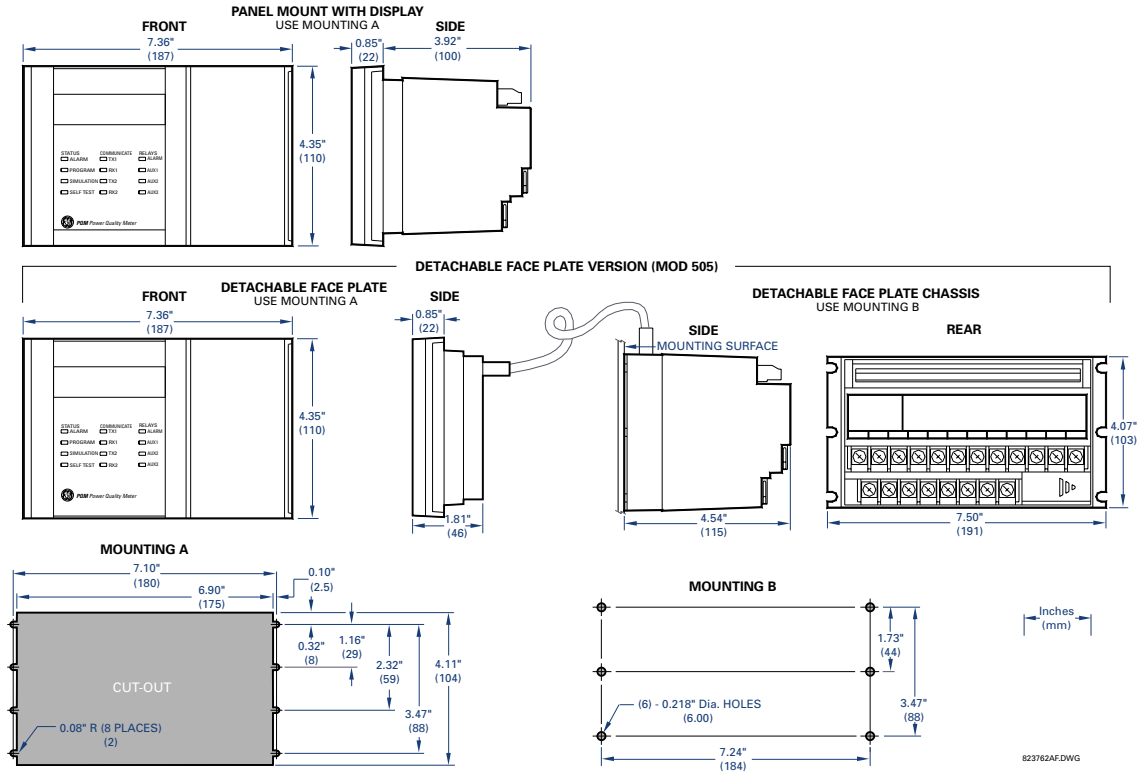

PQM/PPQM Guideform Specifications

For an electronic version of the PQM/PPQM guideform specifications, please visit: www.GEindustrial.com/Multilin/specs, fax your request to 905-201-2098 or email to literature.multilin@indsys.ge.com.



Ordering

PQM	*	*	*	(Order code for all options: PQM-T20-C-A)
PQM				Basic unit with display, all current/voltage/power measurements, 1 RS485 comm port, 1 RS232 comm port
T20				Transducer option; 4 isolated analog outputs 0 – 20 mA and 4 – 20 mA, assignable to all measured parameters, 4 – 20 mA analog input, 2nd RS485 comm port
T1				Transducer option; 4 isolated analog outputs 0 – 1 mA, assignable to all measured parameters, 4 – 20 mA analog input, 2nd RS485 comm port
		C		Control option; 3 additional programmable output relays (total of 4), 4 programmable switch inputs
			A	Power analysis option; harmonic analysis, triggered trace memory waveform capture, event record, data logger
PPQM	*			
150				1 A – 150 A clamp-on CT for wires 0.47" (12 mm) in diameter
500				2 A – 500 A clamp-on CT for wires 1.18" (30 mm) in diameter
1000				2 A – 1000 A clamp-on CT for wires 2.13" (54 mm) in diameter

Modifications:

- MOD 500: Portable test/carrying case
- MOD 501: 20 – 60 VDC/20 – 48 VAC control power
- MOD 502: Tropicalization
- MOD 504: Removable terminal blocks
- MOD 505: Detachable faceplate
- MOD 506: 4-step capacitor bank switching
- MOD 507: -40 to +60° C temperature operation
- MOD 508: 269 communication protocol
- MOD 513: Class 1, division 2 operation
- MOD 516: PQM remote: base unit only
- MOD 517: PQM remote: detachable faceplate only

Accessories:

- *PQMPC Windows® software
- **RS232 to RS485 convertor
- 2.25" collar for limited depth mounting
- RS485 terminating network
- PQM mounting plate to replace MTM Plus

Control Power:

- 90 – 300 VDC/70 – 265 VAC standard
- 20 – 60 VDC/20 – 48 VAC (MOD 501)

* Free upon request

**Required to connect a computer to the PQM RS485 ports

enerVista enabled See page 275.
www.enerVista.com