



HEA Auxiliary Relay Electric Reset Model 12HEA99BT(-)

Manual P/N: GEK-106277

Insert: GEH-2058L

INTRODUCTION

This instruction book, along with the manual GEH-2058, form the instructions for the 12HEA99BT(-) auxiliary relay.

DESCRIPTION

The 12HEA99BT(-) relay is similar to the 12HEA61B235, except that contact 11 is similar to contact 5. The contact arrangement in the reset position is: Closed - 6, 7, 8, 9, 10, 12; Open - 1, 2, 3, 4, 5, 11.

GE Power Management

215 Anderson Avenue, Markham, Ontario

Canada L6E 1B3

Tel: (905) 294-6222 Fax: (905) 294-8512

Internet: <http://www.ge.com/indsys/pm/>



GE Power Management

**215 Anderson Avenue
Markham, Ontario
Canada L6E 1B3
Tel: (905) 294-6222
Fax: (905) 201-2098
www.ge.com/indsys/pm**



INSTRUCTIONS

AUXILIARY RELAYS

HAND RESET WITH Target
Types HEA61
HEA62

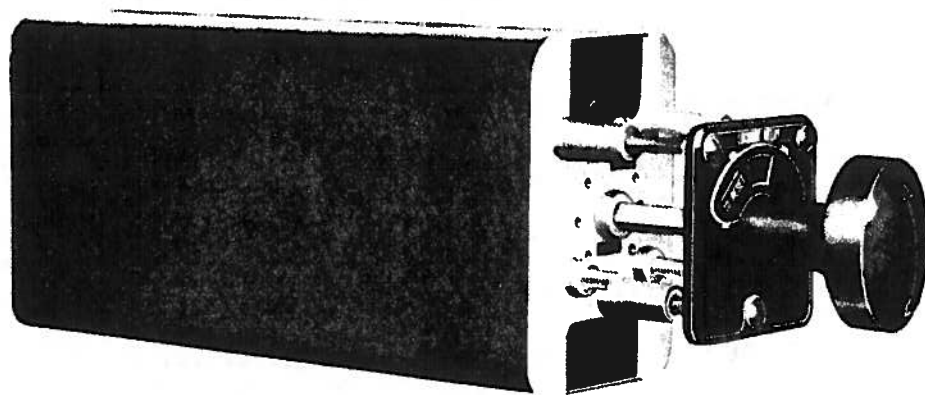

GE Protection and Control
205 Great Valley Parkway
Malvern, PA 19355-1337

CONTENTS

DESCRIPTION	3
CHARACTERISTIC	3
APPLICATION	4
OPERATING CHARACTERISTICS	4
RATINGS	4
BURDENS	5
CONSTRUCTION AND CIRCUITRY	5
INSTALLATION	5
RECEIVING	5
INSTALLATION AND WIRING PRACTICES	6
MOUNTING	7
CONNECTIONS	7
MAINTENANCE	7
PERIODIC TESTS	7
SERVICING	9
CONTACT CLEANING	9
RENEWAL PARTS INSTALLATION	9
RENEWAL PARTS	9

Since the last edition, a change has been made in item 5 under MAINTENANCE PERIODIC TESTS

AUXILIARY RELAYS - HAND RESET

TYPES HEA61
HEA62

DESCRIPTION

The Type HEA relay is a high speed, multi-contact, hand reset, auxiliary relay provided with a mechanical target which indicates whether it is in the tripped or reset position. Table I lists the differences among the various relays covered by these instructions.

TABLE I

MODEL	FIG.	NO. OF CONTACTS	SPECIAL FEATURES AND REMARKS
HEA61A	6	6 + 2 FOR TRIP COIL	-----
HEA61B	7	10 + 2 FOR TRIP COIL	-----
HEA61C	8	16 + 2 FOR TRIP COIL	-----
HEA61CRD	8A	16 + 2 FOR TRIP COIL	RIGHT ANGLE DRIVE RELAY DOWN
HEA61CRL	8B	16 + 2 FOR TRIP COIL	RIGHT ANGLE DRIVE RELAY LEFT
HEA61CRR	8C	16 + 2 FOR TRIP COIL	RIGHT ANGLE DRIVE RELAY RIGHT
HEA61CRU	8D	16 + 2 FOR TRIP COIL	RIGHT ANGLE DRIVE RELAY UP
HEA61M	9**	2 + 2 FOR TRIP COIL	-----
HEA61V	10**	14 + 2 FOR TRIP COIL	-----
HEA62A	11	6 + 2 FOR TRIP COIL	-----
HEA62B	12	10 + 2 FOR TRIP COIL	-----
HEA62C	13	16 + 2 FOR TRIP COIL	-----
HEA62CRD	13A	16 + 2 FOR TRIP COIL	RIGHT ANGLE DRIVE RELAY DOWN
HEA62CRL	13B	16 + 2 FOR TRIP COIL	RIGHT ANGLE DRIVE RELAY LEFT
HEA62CRR	13C	16 + 2 FOR TRIP COIL	RIGHT ANGLE DRIVE RELAY RIGHT
HEA62CRU	13D	16 + 2 FOR TRIP COIL	RIGHT ANGLE DRIVE RELAY UP

** All HEA62 relays have a diode and resistor inserted across the coil circuit. See Fig. 1B.

These instructions do not purport to cover all details or variations in equipment nor to provide for every possible contingency to be met in connection with installation, operation or maintenance. Should further information be desired or should particular problems arise which are not covered sufficiently for the purchaser's purposes, the matter should be referred to the General Electric Company.

To the extent required the products described herein meet applicable ANSI, IEEE and NEMA standards; but no such assurance is given with respect to local codes and ordinances because they vary greatly.

APPLICATION

The Type HEA relays are applicable where it is desired that a number of operations be performed simultaneously. Some of the functions that can be performed by these relays are: trip the main circuit breaker of a system, operate an auxiliary breaker, open a neutral line breaker, trip main and auxiliary field discharge breakers, and operate other relays which, in turn, perform various functions. Another important use of the Type HEA relay is in conjunction with differential relays which protect transformers, rotating apparatus, buses, etc. A typical application is illustrated in Fig. 5.

OPERATING CHARACTERISTICS

The time required to trip the relay from the point of energization of the coil to the closing of the normally open contacts is shown in Fig. 4. The opening time of the normally closed contacts is approximately the same as the closing time of the normally open contacts.

RATINGS

The Type HEA relays are available for all standard coil voltage ratings (intermittent) up to 250 volts DC and 460 volts AC.

The current-closing rating of the contacts is 50 amperes for voltages not exceeding 600 volts. The contacts have a current-carrying capacity of 20 amperes continuously or 50 amperes for one minute. The interrupting rating of the contacts varies with the inductance of the circuit. The values (in amperes) given in Table II, for DC inductive circuits, are based on the average trip coil currents.

TABLE II CONTACT INTERRUPTION RATING

CIRCUIT VOLTS	NON-INDUCTIVE CIRCUIT			INDUCTIVE CIRCUIT		
	NUMBER OF CONTACTS			NUMBER OF CONTACTS		
	1	2 IN SERIES	4 IN SERIES	1	2 IN SERIES	4 IN SERIES
24 DC	6.0	30.0		4.0	20.0	30.0
48 DC	5.0	25.0	40.0	3.0	15.00	25.0
125 DC	2.6	11.0	25.0	2.0	6.25	9.5
250 DC	0.75	2.0	8.0	0.7	1.75	6.5
600 DC	0.25	0.45	1.35	0.15	0.35	1.25
115 AC	40.00	50.0		24.0	50.0	
220 AC	25.00	50.0		12.0	25.0	40.0
440 AC	12.00	25.0		5.0	12.0	20.0
550 AC	6.00	12.0		4.0	10.0	15.0

BURDENS

The burden data of the Type HEA relay is listed in Table III.

TABLE III **BURDENS**

INTERMITTENT RATING	FREQ	COIL RES. OHMS 25°C	AC INRUSH (CURRENT AMPS)	MINIMUM RATING OF TARGET COIL IN EXTERNAL PROTECTIVE RELAY	
				UNIVERSAL TARGET SEAL-IN (CURRENT AMPS)	SEPARATE TARGET & SEAL-IN (CURRENT AMPS)
12	DC	0.4		2.0	
24	DC	1.2		2.0	1.0
32	DC	2.4		2.0	
48	DC	4.5		2.0	1.0
62.5	DC	7.3		2.0	
125	DC	23		0.2	1.0
220	DC	88		0.2	0.2
250	DC	103		0.2	0.2
115	60 CYC	2.4	25	2.0	
208	60 CYC	9.7		2.0	
230	60 CYC	9.7	14	0.2	
460	60 CYC	38.5			

CONSTRUCTION AND CIRCUITRY

The contact section of this relay is built from parts of the Type SB-1 control and transfer switch (see Fig. 1 and 1A).

The operating shaft is held in the reset position by a positive latch. It is released through the action of the operating coil when it attracts the hinged-armature element.

The mechanical target on the escutcheon plate assembly indicated black when the relay is in the reset position and yellow when in the tripped position. To reset the relay after being tripped, the handle is turned clockwise as indicated by the arrow on the escutcheon plate.

In addition to the 2, 6, 10, 14 or 16 sets of contacts as provided, each relay is equipped with two normally closed contacts connected in series for opening the operating coil circuit.

INSTALLATION

RECEIVING

These relays, when not included as a part of a control panel, will be shipped in cartons designed to protect them against damage. Immediately upon receipt of a relay,

GEH-2058

examine it for any damage sustained in transit. If injury or damage resulting from rough handling is evident, file a damage claim at once with the transportation company and promptly notify the nearest General Electric Sales Office.

If the relays are not to be installed immediately, they should be stored in their original cartons in a place that is free from moisture, dust and metallic chips.

INSTALLATION AND WIRING PRACTICES

Careful attention to the wiring and installation of the relay is as important as the proper selection of the relay. Attention to the wiring at the installation and maintaining of the wiring through the life of the relay will result in fewer field problems. The following are recommendations for installation and wiring practices to follow for HEA relays.

The installation of a relay to a panel requires only two items; the holes in the panel for screws and shaft, and the space behind the relay to remove the cover.

The cover should not be removed from the relay during installation to prevent possible damage to shunts and/or latching mechanism.

The front support is designed with cutouts for wires; the top for wires going to fixed contacts, the bottom for wires going to moving contacts. Wiring coming to and from these cutouts should be cabled together by lacing or ties, then clamped to the mounting structure so that no distortion of the switch can occur from tight cables or pulling on the cable.

Covers for relays are available in one size. The standard cover for the HEA relay (4-3/4 inches) is for 24 wires out the top and 24 wires out the bottom. The wire openings are 1-3/4 inches wide by one inch high.

The design of the wire opening is for Type SIS #14 Vulkene insulated switchboard wires (0.150 outside diameter each) General Electric C.I. 57275.

Multiple wires to one terminal should not exceed two #14 wires. When larger than #14 wire is used, a limit of one wire per terminal is recommended. The maximum wire size is #10.

No wires should enter the top cutout and cross down to the lower side of the relay. In doing this, the wire would be outside the barrier and when the cover is installed, would be pushed in against the shunts and prevent proper action of the moving contact. No wires can be outside the barrier width without taking unnecessary risk of relay failure.

The terminal screw is a 10-32 NF2 x 7/16 long binder head, nickle-plated brass screw. The diameter of the head is 13/32 inch. This is the maximum outside diameter of any #10 crimp-type terminal used to terminate wires. When the shank of the crimp-type terminal requires insulation, the type with insulated shanks should be used. Shanks of crimp terminals should be bent slightly up away from the fixed contacts to avoid possibility of gap interference.

GEH-2058

Never use tape wrapped around the shank and wire insulation. The tape may eventually unwrap and could possibly position itself in the contact gap preventing the relay from operating properly.

Moving contacts have the terminal screws positioned at 45 degrees and facing away from the relay axis. This position should never be changed at time of installation. The reason for this is that if the moving contact terminal is turned in the opposite direction from which the screw is pointed, the contact will open up and be loose on the hexagon barrier boss. This, in turn, affects the action and gap of the moving contact by stretching the shunt. The terminal should never be changed from the position in which it is received from the factory.

The terminal screws are tightened to 15-20 inch-pounds torque. When applying this torque to tighten the terminal screw on the moving contact, caution should be exercised not to exceed 20 pounds force in the direction the screw is being driven. It is also important that a correct fitting screwdriver be used to prevent relay contact damage and screw head distortion.

MOUNTING

The relay should be mounted on a vertical surface. The relay may be mounted on panels up to two inches thick. If the panel thickness is not specified when ordering, the relay will be furnished for panels up to 3/16 inch thick. The "x 2" after the group number identifies the panel thickness (12HEA61A 224x2). By changing the "x 2" to "x 4" the relay will be suitable for 1/4 inch panel. The number after the "x" equals increments of 1/16 inch, up to 32 for two inches.

The outline and panel drilling diagrams for the various types of HEA relays are shown in Figs. 6 to 13D, inclusive.

CONNECTIONS

The internal connection diagrams for the various types of HEA relays are shown in Figs. 6 to 13D, inclusive. When connecting switchboard wires to the coil circuit, be sure they are kept away from the arc path which occurs when the relay contacts interrupt the coil circuit.

NOTE 1: When connecting wires to all types of switches, excessive thrust must not be applied to the heads of the screws as the switch contacts may become distorted permitting rotation on the switch barrier supports. Likewise the connected wires must not be pulled away from the switch contacts when forming a wiring harness.

NOTE 2: It is also important that a correct fitting screwdriver be used to prevent switch contact damage and screw head distortion.

MAINTENANCE

PERIODIC TESTS

During any scheduled outage of the equipment and preferably at yearly intervals, the relay should be tripped electrically to insure that it is in good operating condition and that all the circuits are complete so that the breakers can be tripped.

GEH-2058

Remove cover, visually inspect relay and trip manually by applying force on the armature (Step 7 below).

This electrical test may be performed at 70 percent of rated voltage by inserting the proper value of series resistance in the coil circuit as listed in Table IV being careful to apply the test voltage only long enough to trip the relay.

TABLE IV

VOLTS DC	12	24	32	48	62.5	110	125	220	250
OHM RESIS- TANCE FOR TEST	0.2	0.5	1.0	2.0	3.0	7.0	10.0	38.0	40.0

The following check list gives recommendations to insure the relay functions properly.

1. Before installation customer should read this instruction book, GEH-2058. A publication, GET-7293, is also available.
2. Check nameplate for correct model number and voltage rating.
3. Check for proper coil and resistance (Table III).
4. Be sure coil is connected properly using both coil contacts for double break action.
5. Each of the coil contacts should have 1/4 inch $\pm 1/32$ " contact gap when open.
6. Check that rollers spin freely on latching assembly.
7. Relay should trip by hand with a 0.025 shim between armature and pole piece.
8. If tripping voltage is too high (should trip at 70 percent of rated voltage), add 0.015 shim (V-6149118) under pole piece, then repeat No. 7.
9. Wait 30 seconds between operations for continued operation test.
10. In resetting relay, the handle should not be forced against the latch to see if latching has occurred; instead the handle should be released immediately after resetting so you do not prevent or delay tripping.
11. Do not try to reset with trip circuit still energized.
12. Be sure the wires do not interfere with the latching mechanism and are within outer edges of barriers.
13. Be sure tie bolts are tight (25 inch-pounds).

SERVICING

CONTACT CLEANING

For cleaning fine silver contacts, a flexible burnishing tool should be used. This consists of a flexible strip of metal with an etched roughened surface, resembling in effect a superfine file. The polishing action is so delicate that no scratches are left, yet corroded material will be removed rapidly and thoroughly. The flexibility of the tool insures the cleaning of the actual points of contact.

The burnishing tool described is included in the standard relay tool kit obtainable from the factory.

RENEWAL PART INSTALLATION

To remove the moving contact, position the relay so that the contact is open. Remove binding head screw and round head screw (Fig. 2) which hold the shunt to the terminal, press in, on the the top of the contact, to release the torque at its lower end (Fig. 3) and pull the contact upward and off.

The moving contact has a shoe that is assembled between the contact spring and the contact. When assembling a new moving contact, the end of the moving contact support must be inserted between the shoe and the moving contact. Then the contact may slide down into place and the screws may be replaced. When replacing the round head screw be sure the lockwasher is replaced and be careful to avoid creasing the thin metal strips of the shunt. Operate the relay and observe whether the contacts meet squarely and simultaneously. The contacts can be adjusted by bending slightly with smooth faced pliers. After adjustment there should be a 1/32 inch minimum gap, with the contacts closed, between the moving contact and the moving contact support (Fig. 2).

Damage to a fixed contact requires replacement of the complete assembly of fixed contacts and support. Remove screws, change assemblies and replace screws. Check alignment of contacts.

To remove a defective coil, disconnect the leads from contacts, then remove staked screw in bottom of pole piece. Slide coil from under guard and armature being careful not to lose shim under pole piece. Remove pole piece and position in replacement coil. Position shim under pole piece and slide coil assembly under armature and guard. Replace screw and re-store. Check new coil per Items 3 through 12 on check list.

When cams, barriers, moving contact supports, etc., need to be replaced, it is recommended that the relay be returned to the factory for repair and return.

RENEWAL PARTS

It is recommended that sufficient quantities of renewal parts be carried in stock to enable the prompt replacement of any that are worn, broken or damaged.

When ordering renewal parts, address the nearest Sales Office of the General Electric Company, specifying the quantity required and describing the parts.

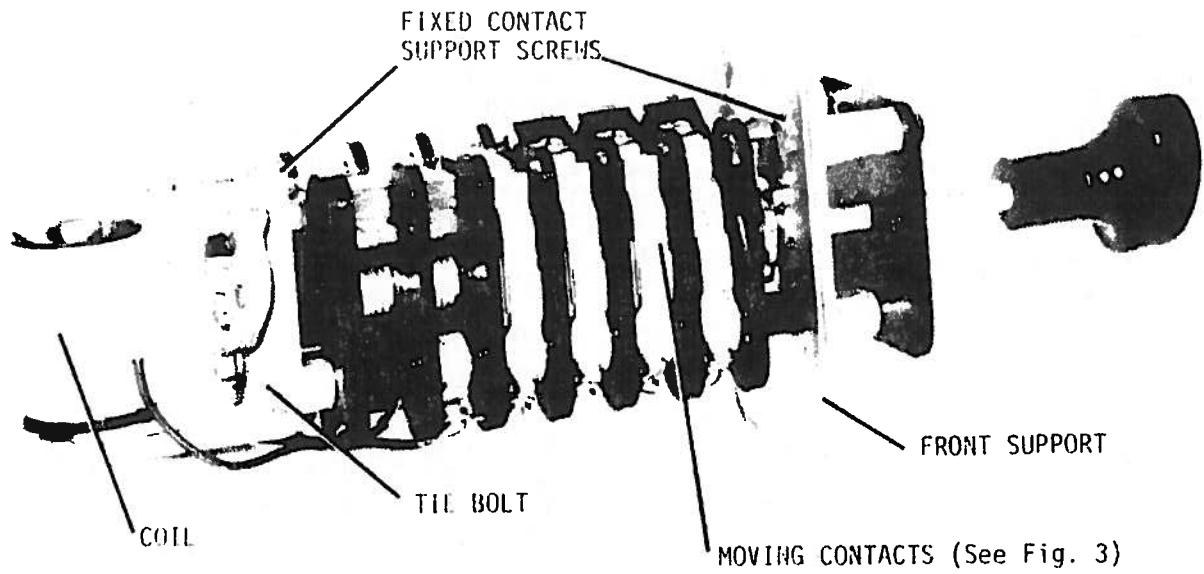

Fig. 1 (8031895) Six Contact HEA61 Relay in Tripped Position, with Cover Removed

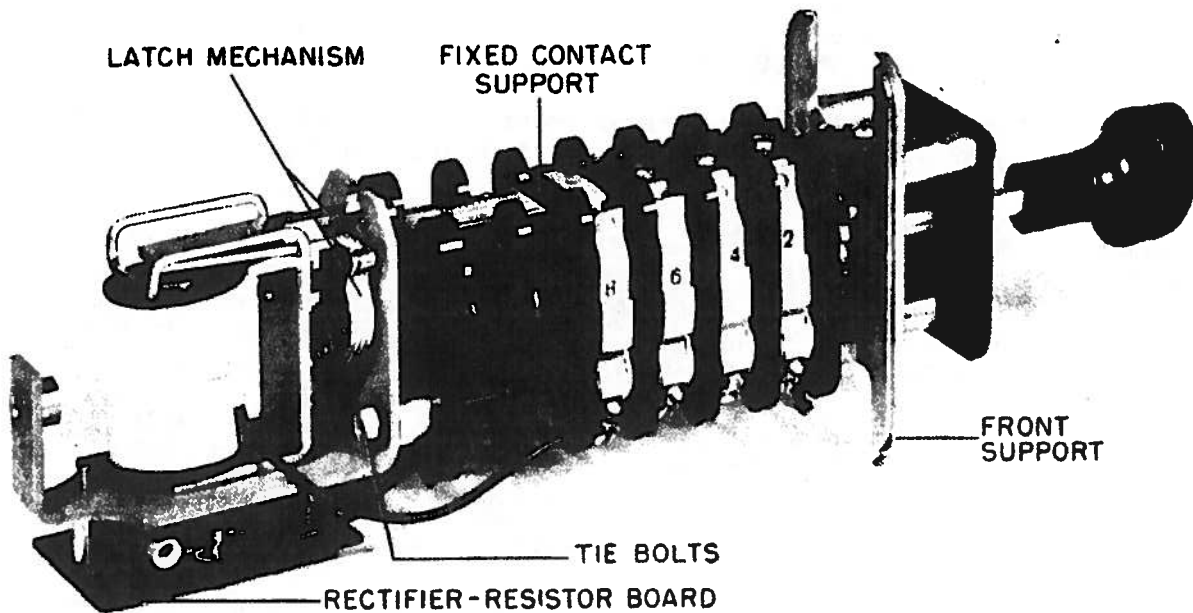

Fig. 1A (8028243) Type HEA62 with Diode-Resistor Board

GEH-2058

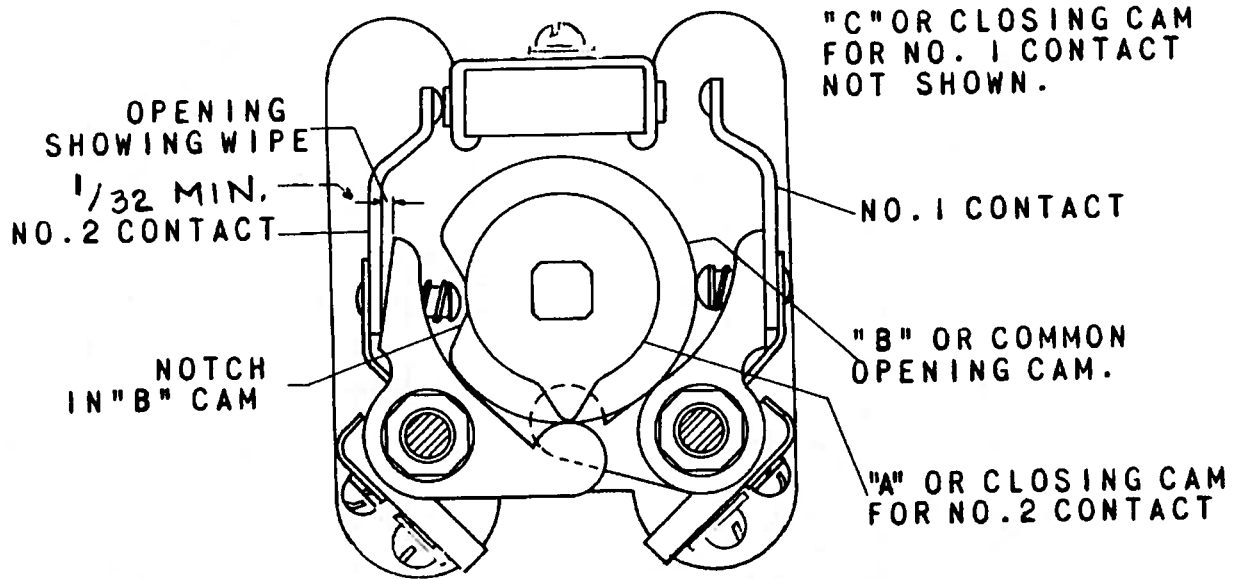

Fig. 2 (6507946-2) Typical Section Showing Operation of Cams - Front View

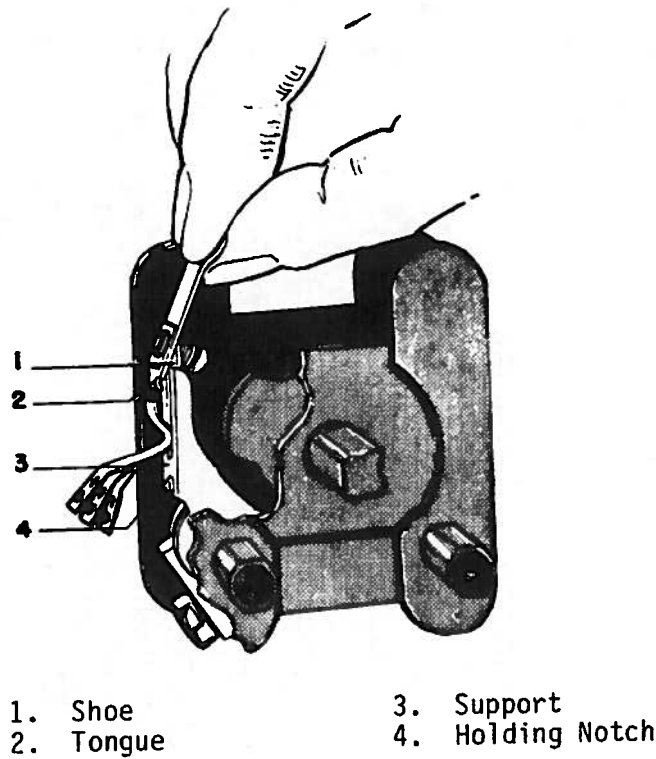

Fig. 3 (8918418) Removing and Replacing Moving Contact

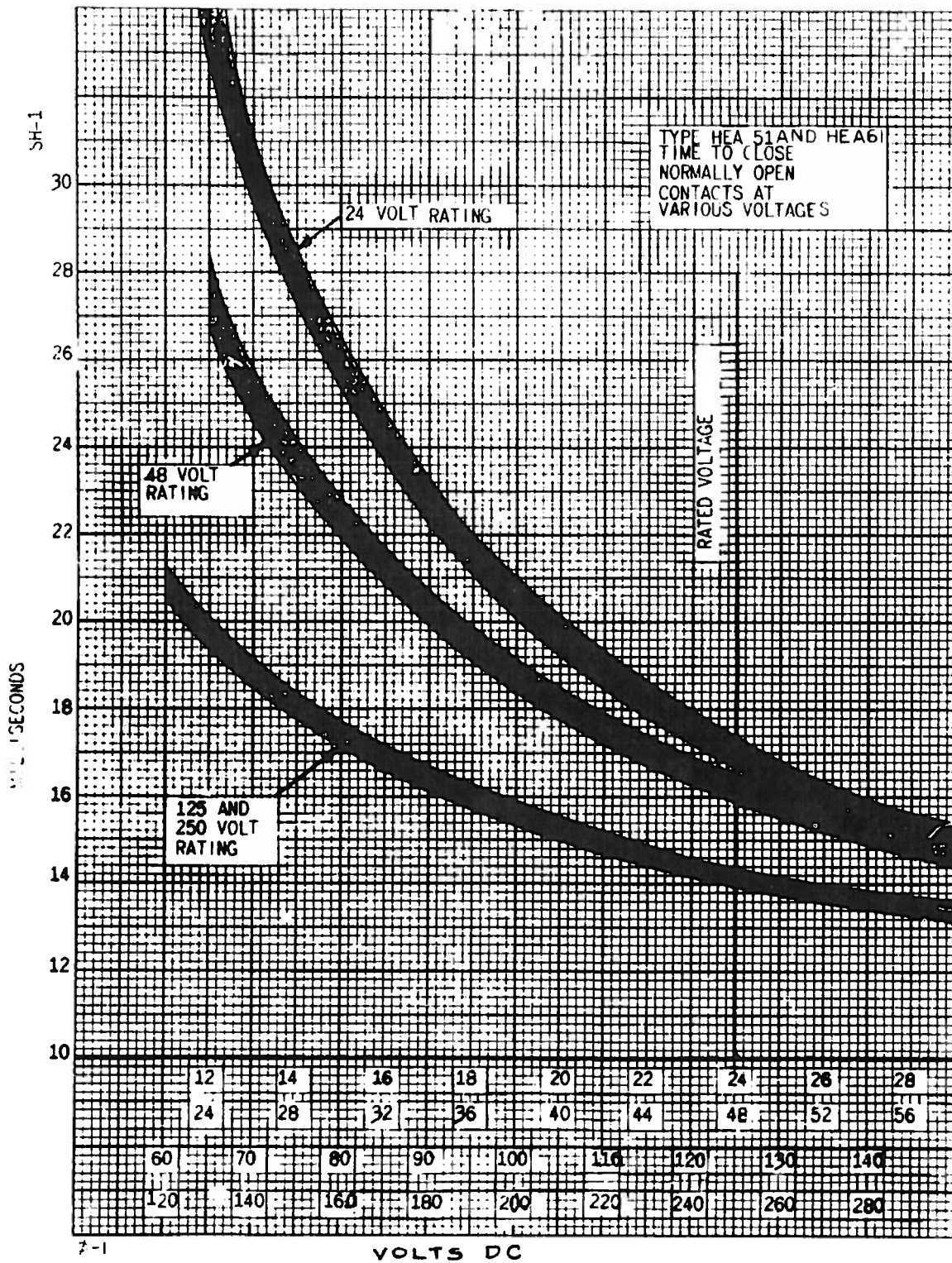

Fig. 4 (0127A9510-1) Typical Time-voltage Characteristics of Type HEA61 Relay

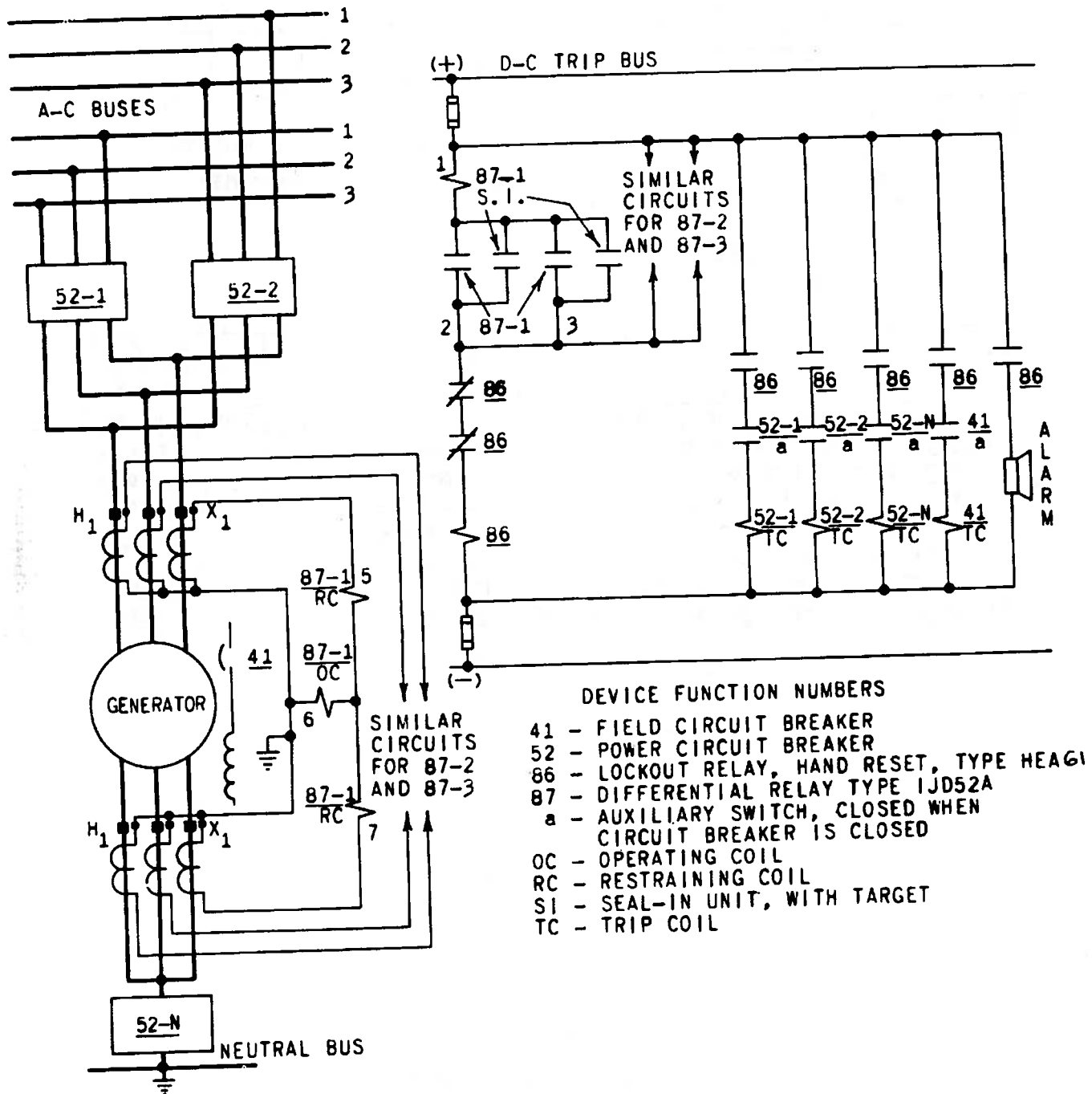
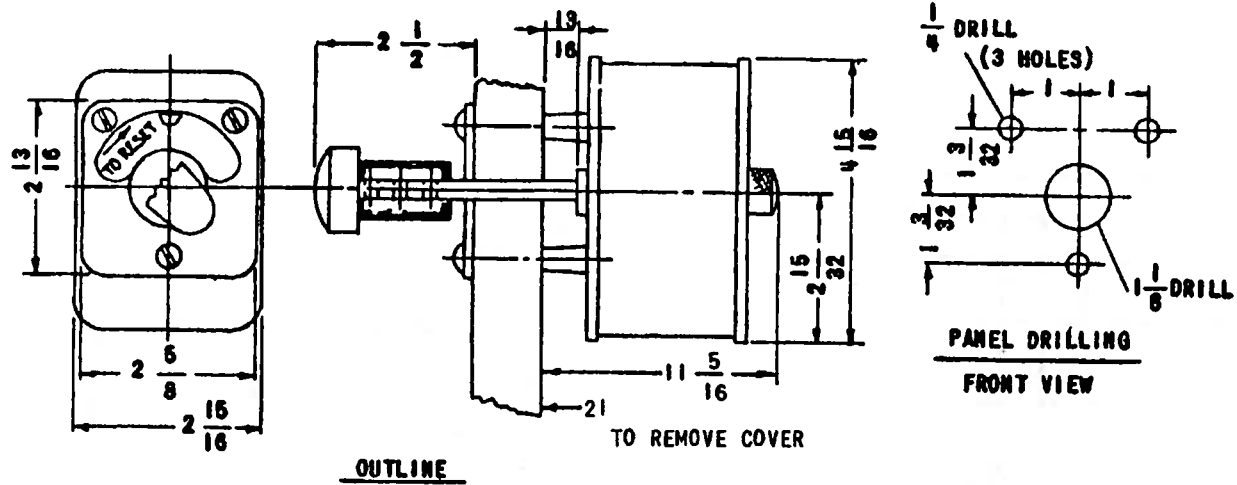

Fig. 5 (0165A7690-0) Typical Application of Type HEA Relays as Auxiliary Device in the Differential Protection of a Generator

GEH-2058



CYCLES	RELAY FORM NUMERAL																CONTACT ARRANGEMENT		
	DC	DC	DC	DC	DC	DC	DC	DC	50/60	25/60	50/60	25/60	50/60	DC	DC			RESET POSITION	
VOLTS	250	125	48	24	60	32	12	220	115	230	230	85	460	115	208	275	145	OPEN	CLOSED
MODEL 12HEA61A	210	220	230	240	250	260	270	280	290	300	310	320	330	340	350	360	370	NONE	1 TO 6
	211	221	231	241	251	261	271	281	291	301	311	321	331	341	351	361	371	1	2 TO 6
	212	222	232	242	252	262	272	282	292	302	312	322	332	342	352	362	372	1 & 2	3 TO 6
	213	223	233	243	253	263	273	283	293	303	313	323	333	343	353	363	373	1 TO 3	4 TO 6
	214	224	234	244	254	264	274	284	294	304	314	324	334	344	354	364	374	1 TO 4	5 & 6
	215	225	235	245	255	265	275	285	295	305	315	325	335	345	355	365	375	1 TO 5	6
216	226	236	246	256	266	276	286	296	306	316	326	336	346	356	366	376	1 TO 6	NONE	

HANDLE END OF SWITCH

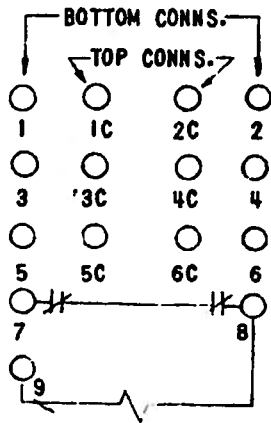

INTERNAL CONNECTIONS

NOTE: CONTACTS 7 & 8 SHOWN IN RESET POSITION

Fig. 6 (0165A7675-4) Outline, Panel Drilling and Internal Connections for HEA61A Relay

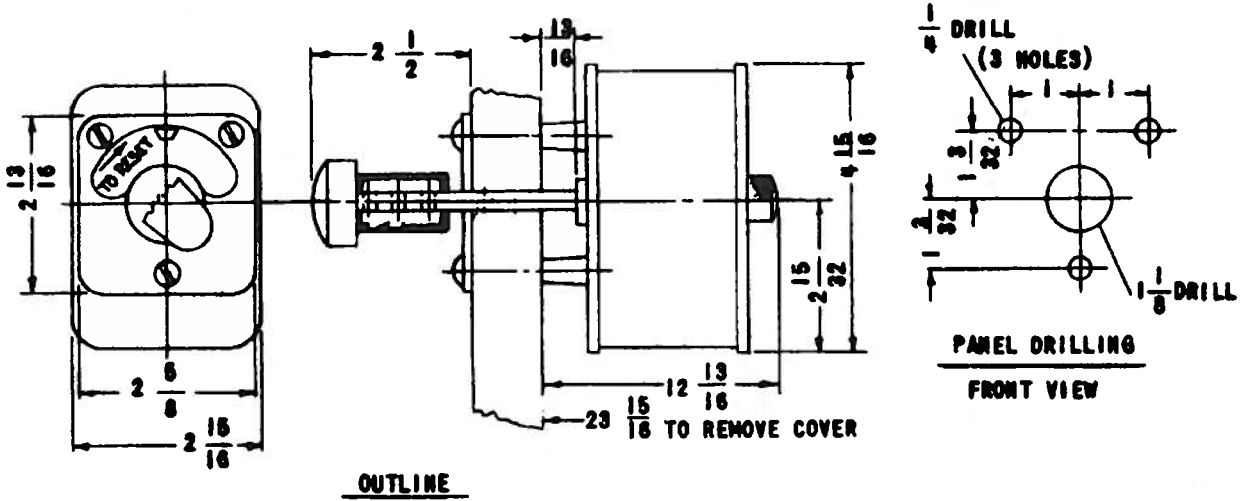

CYCLES	RELAY FORM NUMERAL											CONTACT ARRANGEMENT	
	DC	DC	DC	DC	DC	DC	DC	50/60	50/60	DC		RESET	POSITION
	VOLTS	250	125	48	24	32	230	220	115	230	480	12	OPEN
MODEL 12HEA61B	210	230	250	270	290	310	330	350	370	410	430	NONE	1 TO 10
	211	231	251	271	291	311	331	351	371	411	431	1	2 TO 10
	212	232	252	272	292	312	332	352	372	412	432	1 & 2	3 TO 10
	213	233	253	273	293	313	333	353	373	413	433	1 TO 3	4 TO 10
	214	234	254	274	294	314	334	354	374	414	434	1 TO 4	5 TO 10
	215	235	255	275	295	315	335	355	375	415	435	1 TO 5	6 TO 10
	216	236	256	276	296	316	336	356	376	416	436	1 TO 6	7 TO 10
	217	237	257	277	297	317	337	357	377	417	437	1 TO 7	8 TO 10
	218	238	258	278	298	318	338	358	378	418	438	1 TO 8	9 & 10
	219	239	259	279	299	319	339	359	379	419	439	1 TO 9	10
	220	240	260	280	300	320	340	360	380	420	440	1 TO 10	NONE

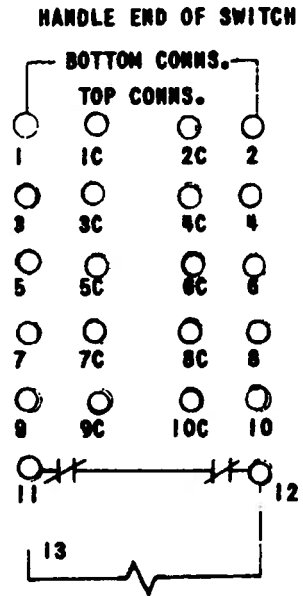

INTERNAL CONNECTIONS

NOTE-CONTACTS 11 & 12 SHOWN IN RESET POSITION.

Fig. 7 (0165A7676-3) Outline, Panel Drilling and Internal Connections for HEA61B Relay

GEH-2058

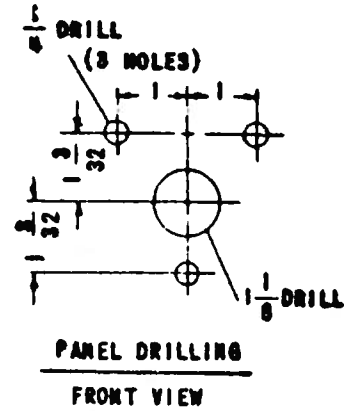
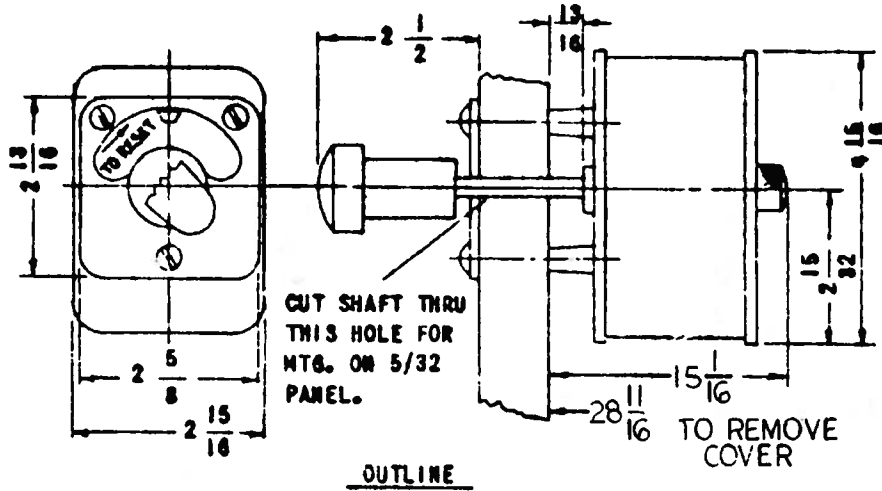

COIL	HERTZ	VOLTS	4.5	1.2	1.8	2.4	3.0	3.6	4.5	5.0	6.0	7.3	8.4	10.0	12.0	15.0	17.3	CONTACT ARRANGEMENT	RESET POSITION
103	DC	23	DC	DC	DC	DC	DC	DC	DC	DC	DC	DC	DC	DC	DC	DC	DC	1 TO 3	OPEN
250	DC	125	46	24	220	115	460	230	275	320	375	425	480	540	600	670	750	1 TO 4	CLOSED
210	DC	230	250	270	290	310	330	350	370	390	410	430	450	470	490	510	530	NONE	NONE
211	DC	231	251	271	291	311	331	351	371	391	411	431	451	471	491	511	531	1	2 TO 16
212	DC	232	252	272	292	312	332	352	372	392	412	432	452	472	492	512	532	1 & 2	3 TO 16
213	DC	233	253	273	293	313	333	353	373	393	413	433	453	473	493	513	533	1 TO 3	4 TO 16
214	DC	234	254	274	294	314	334	354	374	394	414	434	454	474	494	514	534	1 TO 4	5 TO 16
215	DC	235	255	275	295	315	335	355	375	395	415	435	455	475	495	515	535	1 TO 5	6 TO 16
216	DC	236	256	276	296	316	336	356	376	396	416	436	456	476	496	516	536	1 TO 6	7 TO 16
217	DC	237	257	277	297	317	337	357	377	397	417	437	457	477	497	517	537	1 TO 7	8 TO 16
218	DC	238	258	278	298	318	338	358	378	398	418	438	458	478	498	518	538	1 TO 8	9 TO 16
219	DC	239	259	279	299	319	339	359	379	399	419	439	459	479	499	519	539	1 TO 9	10 TO 16
220	DC	240	260	280	300	320	340	360	380	400	420	440	460	480	500	520	540	1 TO 10	11 TO 16
221	DC	241	261	281	301	321	341	361	381	401	421	441	461	481	501	521	541	1 TO 11	12 TO 16
222	DC	242	262	282	302	322	342	362	382	402	422	442	462	482	502	522	542	1 TO 12	13 TO 16
223	DC	243	263	283	303	323	343	363	383	403	423	443	463	483	503	523	543	1 TO 13	14 TO 16
224	DC	244	264	284	304	324	344	364	384	404	424	444	464	484	504	524	544	1 TO 14	15 TO 16
225	DC	245	265	285	305	325	345	365	385	405	425	445	465	485	505	525	545	1 TO 15	16
226	DC	246	266	286	306	326	346	366	386	406	426	446	466	486	506	526	546	1 TO 16	NONE

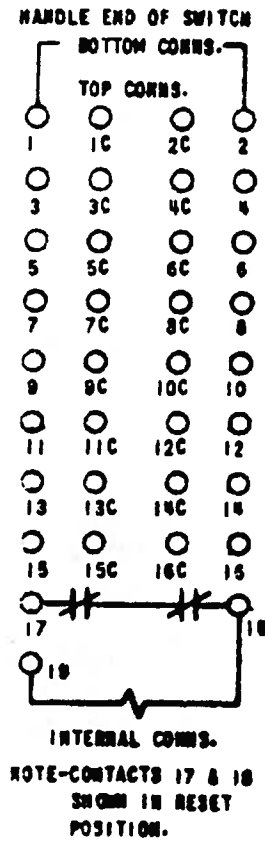

DUPLICATE OF LOST TRACING

Fig. 8 (0165A7677-4) Outline, Panel Drilling and Internal Connections for HEA61C Relay

GEH-2058

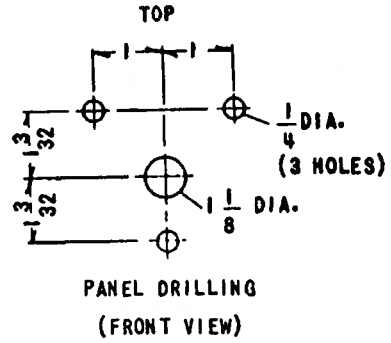
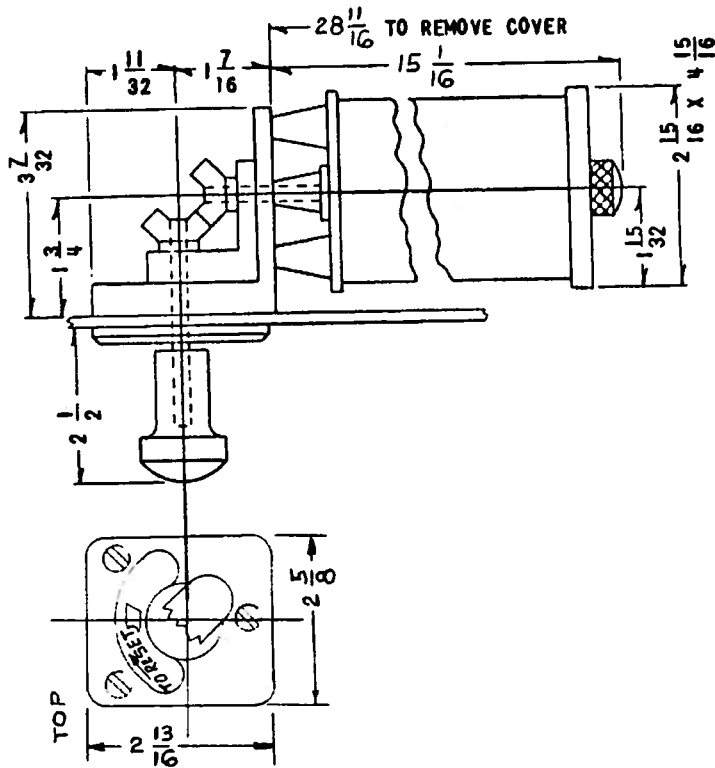

HANDLE END OF SWITCH

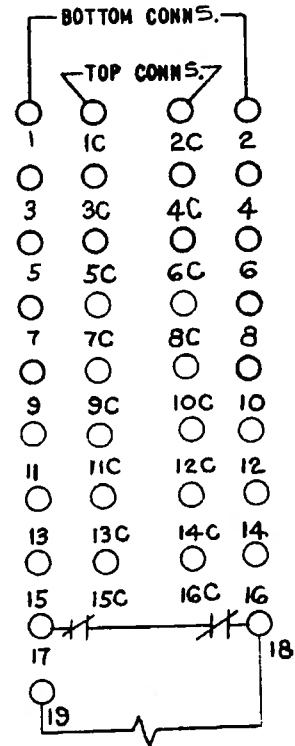

CYCLES	RELAY FORM NUMBER								CONTACT ARRANGEMENT		
	DC	DC	DC	DC	DC	50/60			DC	RESET	POSITION
MODEL 12 HEA61CRD	250	125	48	24	220	115	460	230	275	OPEN	CLOSED
	210	230	250	270	290	310	330	350	370	NONE	1 TO 16
	211	231	251	271	291	311	331	351	371	1	2 TO 16
	212	232	252	272	292	312	332	352	372	1 & 2	3 TO 16
	213	233	253	273	293	313	333	353	373	1 TO 3	4 TO 16
	214	234	254	274	294	314	334	354	374	1 TO 4	5 TO 16
	215	235	255	275	295	315	335	355	375	1 TO 5	6 TO 16
	216	236	256	276	296	316	336	356	376	1 TO 6	7 TO 16
	217	237	257	277	297	317	337	357	377	1 TO 7	8 TO 16
	218	238	258	278	298	318	338	358	378	1 TO 8	9 TO 16
	219	239	259	279	299	319	339	359	379	1 TO 9	10 TO 16
	220	240	260	280	300	320	340	360	380	1 TO 10	11 TO 16
	221	241	261	281	301	321	341	361	381	1 TO 11	12 TO 16
	222	242	262	282	302	322	342	362	382	1 TO 12	13 TO 16
	223	243	263	283	303	323	343	363	383	1 TO 13	14 TO 16
	224	244	264	284	304	324	344	364	384	1 TO 14	15 TO 16
	225	245	265	285	305	325	345	365	385	1 TO 15	16 TO 16
	226	246	266	286	306	326	346	366	386	1 TO 16	NONE

Fig. 8A (0195A9035-1) Outline, Panel Drilling and Internal Connections for Relay HEA61CRD

GEH-2058

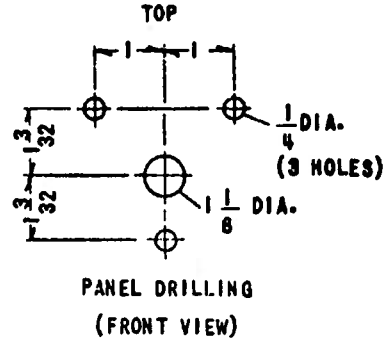
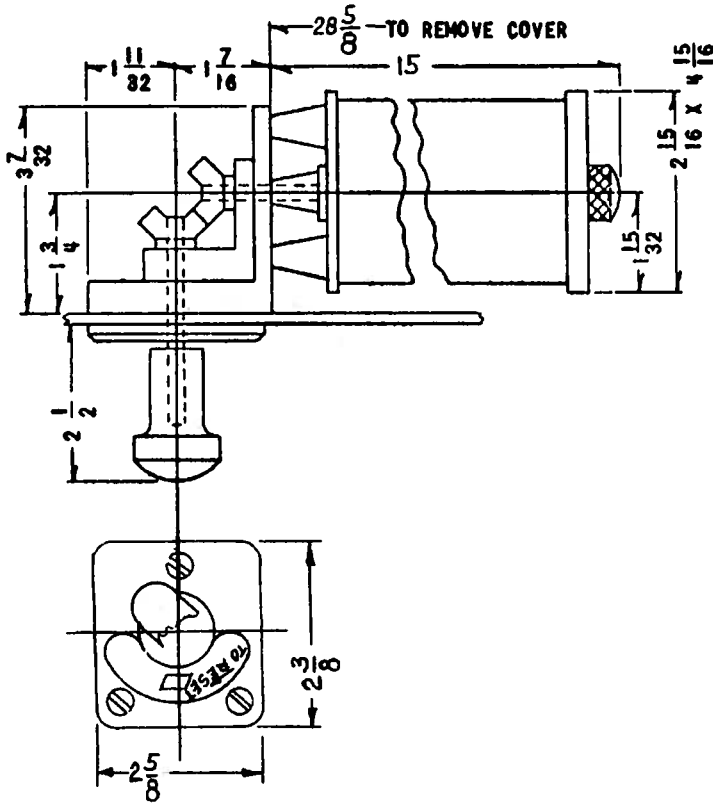

HANDLE END OF SWITCH

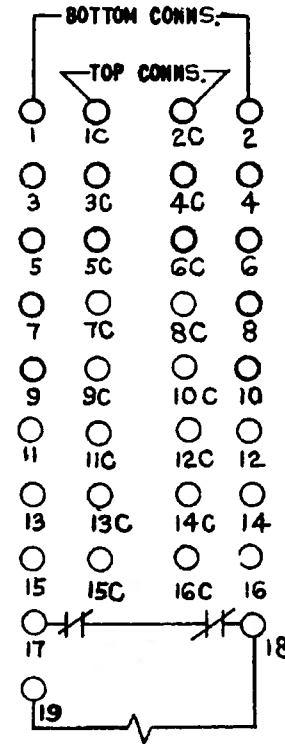

INTERNAL CONNECTIONS
NOTE - CONTACTS 17 & 18
SHOWN IN RESET
POSITION.

		RELAY FORM NUMBER							CONTACT ARRANGEMENT			
		DC	DC	DC	DC	DC	50/60	DC	RESET	POSITION		
CYCLES	DC	250	125	48	24	220	115	460	230	275	OPEN	CLOSED
	VOLTS	210	230	250	270	290	310	330	350	370	NONE	1 TO 16
MODEL 12 HEA61CRL		211	231	251	271	291	311	331	351	371	1	2 TO 16
		212	232	252	272	292	312	332	352	372	1 & 2	3 TO 16
		213	233	253	273	293	313	333	353	373	1 TO 3	4 TO 16
		214	234	254	274	294	314	334	354	374	1 TO 4	5 TO 16
		215	235	255	275	295	315	335	355	375	1 TO 5	6 TO 16
		216	236	256	276	296	316	336	356	376	1 TO 6	7 TO 16
		217	237	257	277	297	317	337	357	377	1 TO 7	8 TO 16
		218	238	258	278	298	318	338	358	378	1 TO 8	9 TO 16
		210	239	259	279	299	319	339	359	379	1 TO 9	10 TO 16
		220	240	260	280	300	320	340	360	380	1 TO 10	11 TO 16
		221	241	261	281	301	321	341	361	381	1 TO 11	12 TO 16
		222	242	262	282	302	322	342	362	382	1 TO 12	13 TO 16
		223	243	263	283	303	323	343	363	383	1 TO 13	14 TO 16
		224	244	264	284	304	324	344	364	384	1 TO 14	15 TO 16
		225	245	265	285	305	325	345	365	385	1 TO 15	16 TO 16
		226	246	266	286	306	326	346	366	386	1 TO 16	NONE

Fig. 8B (0195A9033-1) Outline, Panel Drilling and Internal Connections for Relay HEA61CRL

GEH-2058

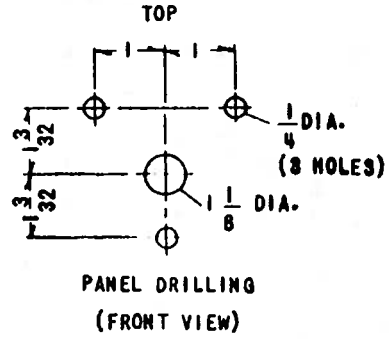
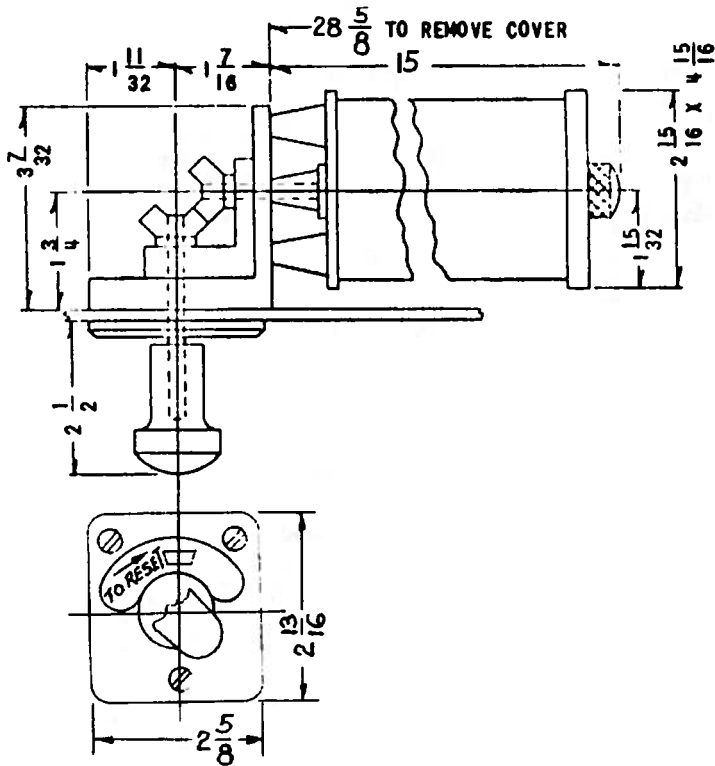

HANDLE END OF SWITCH

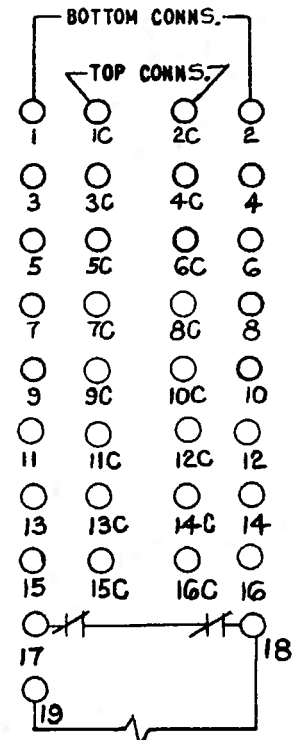

INTERNAL CONNECTIONS
NOTE - CONTACTS
17 & 18 SHOWN IN
RESET POSITION.

CYCLES	RELAY FORM NUMBER								CONTACT ARRANGEMENT		
	DC	DC	DC	DC	DC	50/60			RESET	POSITION	
VOLTS	250	125	48	24	220	115	460	230	275	OPEN	CLOSED
MODEL 12 HEA61CRR	210	230	250	270	290	310	330	350	370	NONE	1 TO 16
	211	231	251	271	291	311	331	351	371	1	2 TO 16
	212	232	252	272	292	312	332	352	372	1 & 2	3 TO 16
	213	233	253	273	293	313	333	353	373	1 TO 3	4 TO 16
	214	234	254	274	294	314	334	354	374	1 TO 4	5 TO 16
	215	235	255	275	295	315	335	355	375	1 TO 5	6 TO 16
	216	236	256	276	296	316	336	356	376	1 TO 6	7 TO 16
	217	237	257	277	297	317	337	357	377	1 TO 7	8 TO 16
	218	238	258	278	298	318	338	358	378	1 TO 8	9 TO 16
	219	239	259	279	299	319	339	359	379	1 TO 9	10 TO 16
	220	240	260	280	300	320	340	360	380	1 TO 10	11 TO 16
	221	241	261	281	301	321	341	361	381	1 TO 11	12 TO 16
	222	242	262	282	302	322	342	362	382	1 TO 12	13 TO 16
	223	243	263	283	303	323	343	363	383	1 TO 13	14 TO 16
	224	244	264	284	304	324	344	364	384	1 TO 14	15 TO 16
	225	245	265	285	305	325	345	365	385	1 TO 15	16
226	246	266	286	306	326	346	366	386	1 TO 16	NONE	

Fig. 8C (0195A9034-1) Outline, Panel Drilling and Internal Connections for Relay HEA61CRR

GEH-2058

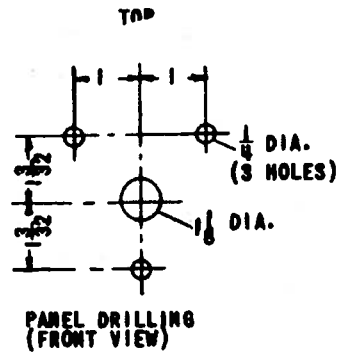
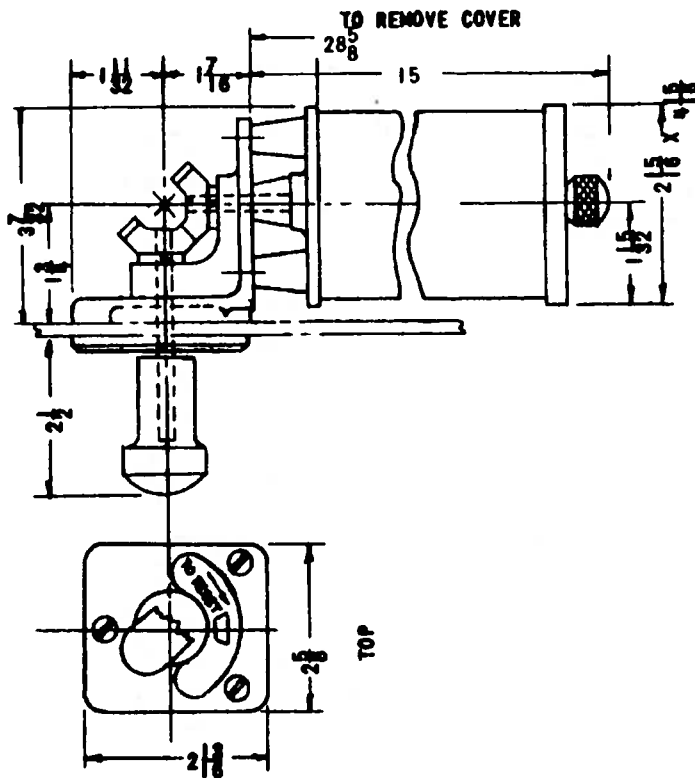

HANDLE END OF SWITCH

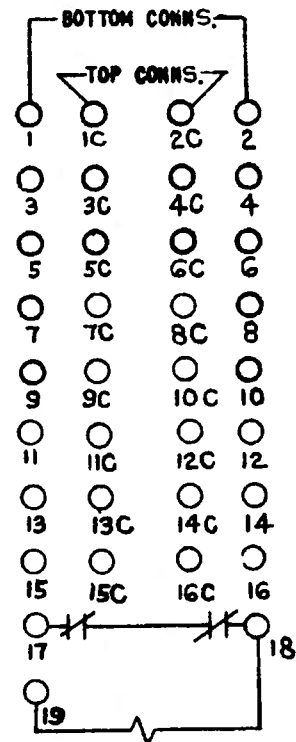

INTERNAL CONNECTIONS
NOTE-CONTACTS 17 & 18
SHOWN IN RESET
POSITION.

		RELAY FORM NUMBER								CONTACT ARRANGEMENT		
		DC	DC	DC	DC	DC	50/60			RESET	POSITION	
CYCLES	VOLTS	250	125	48	24	220	115	460	230	275	OPEN	CLOSED
MODEL 12 HEA61CRU		210	230	250	270	290	310	330	350	370	NONE	1 TO 16
		211	231	251	271	291	311	331	351	371	1	2 TO 16
		212	232	252	272	292	312	332	352	372	1 & 2	3 TO 16
		213	233	253	273	293	313	333	353	373	1 TO 3	4 TO 16
		214	234	254	274	294	314	334	354	374	1 TO 4	5 TO 16
		215	235	255	275	295	315	335	355	375	1 TO 5	6 TO 16
		216	236	256	276	296	316	336	356	376	1 TO 6	7 TO 16
		217	237	257	277	297	317	337	357	377	1 TO 7	8 TO 16
		218	238	258	278	298	318	338	358	378	1 TO 8	9 TO 16
		210	239	259	279	299	319	339	359	379	1 TO 9	10 TO 16
		220	240	260	280	300	320	340	360	380	1 TO 10	11 TO 16
		221	241	261	281	301	321	341	361	381	1 TO 11	12 TO 16
		222	242	262	282	302	322	342	362	382	1 TO 12	13 TO 16
		223	243	263	283	303	323	343	363	383	1 TO 13	14 TO 16
		224	244	264	284	304	324	344	364	384	1 TO 14	15 TO 16
		225	245	265	285	305	325	345	365	385	1 TO 15	16 16
		226	246	266	286	306	326	346	366	386	1 TO 16	NONE

Fig. 8D (0195A9036-0) Outline, Panel Drilling and Internal Connections for Relay HEA61CRU

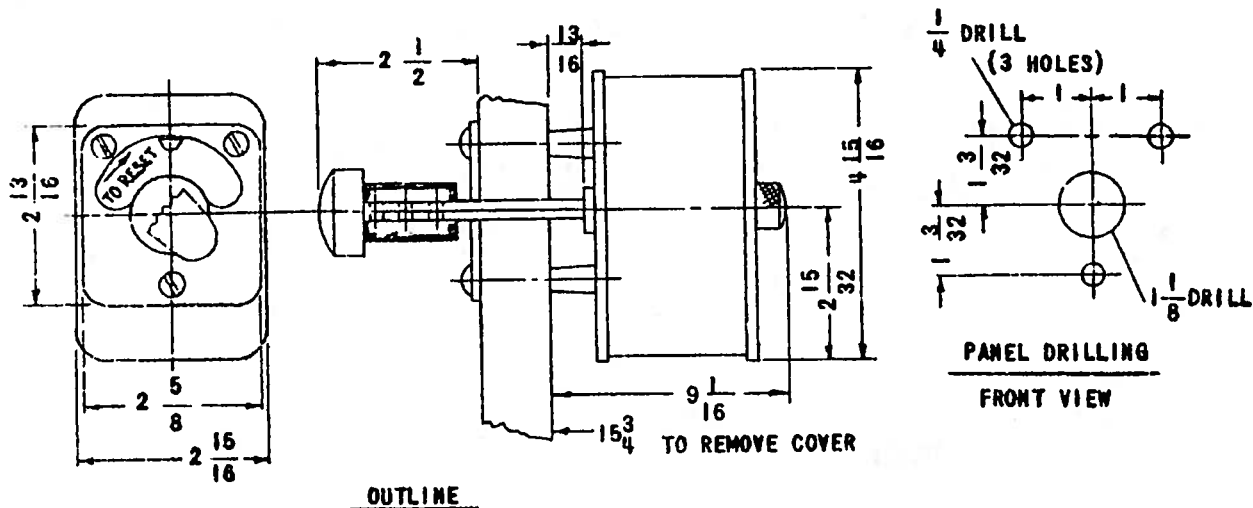

CYCLES	RELAY FORM NUMERAL														CONTACT ARRANGEMENT		
	DC	DC	DC	DC	DC	DC	DC	DC	50/60	25	DC	50/60	DC			RESET	POSITION
VOLTS	250	125	48	24	60	32	12	220	115	230	230	110	460	275		OPEN	CLOSED
MODEL	10	20	30	40	50	60	70	80	90	100	110	120	130	140		3 & 4	NONE
12HEA61M	11	21	31	41	51	61	71	81	91	101	111	121	131	141		3	4
	12	22	32	42	52	62	72	82	92	102	112	122	132	142		NONE	3 & 4

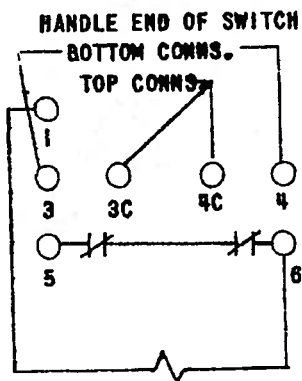

INTERNAL CONNECTIONS

NOTE-CONTACTS 5 & 6 SHOWN IN RESET POSITIONS.

Fig. 9 (0165A7681-2) Outline, Panel Drilling and Internal Connections for HEA61M Relay

GEH-2058

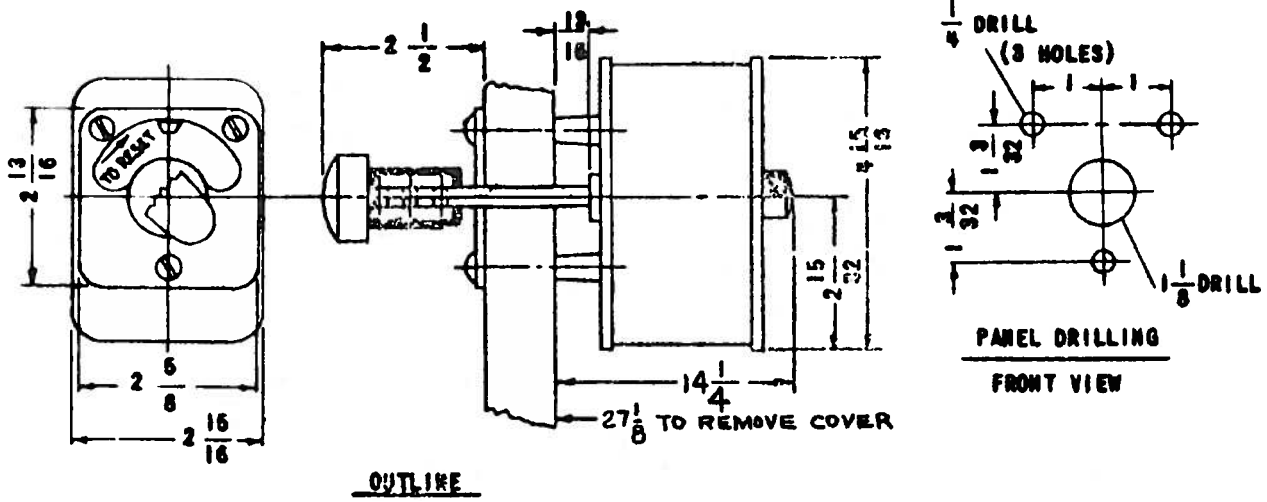

CYCLES	RELAY FORM NUMERAL								CONTACT ARRANGEMENT		
	DC	DC	DC	DC	50/60	50/60	DC			RESET POSITION	
VOLTS	250	125	48	24	115	230	220			OPEN	CLOSED
MODEL 12HEAG1V	10	30	50	70	90	110	130			NONE	1 TO 14
	11	31	51	71	91	111	131			1	2 TO 14
	12	32	52	72	92	112	132			1 & 2	3 TO 14
	13	33	53	73	93	113	133			1 TO 3	4 TO 14
	14	34	54	74	94	114	134			1 TO 4	5 TO 14
	15	35	55	75	95	115	135			1 TO 5	6 TO 14
	16	36	56	76	96	116	136			1 TO 6	7 TO 14
	17	37	57	77	97	117	137			1 TO 7	8 TO 14
	18	38	58	78	98	118	138			1 TO 8	9 TO 14
	19	39	59	79	99	119	139			1 TO 9	10 TO 14
	20	40	60	80	100	120	140			1 TO 10	11 TO 14
	21	41	61	81	101	121	141			1 TO 11	12 TO 14
	22	42	62	82	102	122	142			1 TO 12	13 TO 14
	23	43	63	83	103	123	143			1 TO 13	14
24	44	64	84	104	124	144			1 TO 14	NONE	

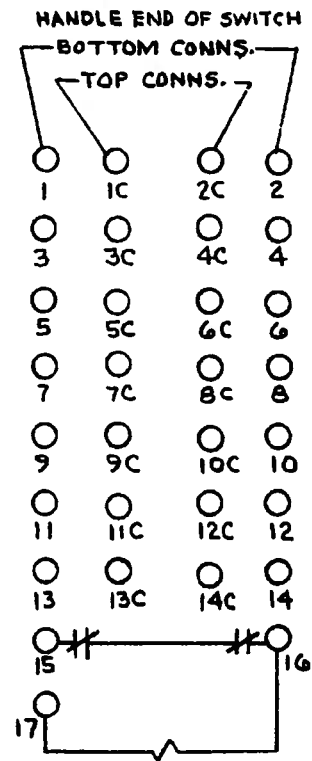

INTERNAL CONNECTIONS
NOTE: CONTACTS 15 & 16
SHOWN IN RESET POSITION.

Fig. 10 (0165A7686-2) Outline, Panel Drilling, and Internal Connections for Relay HEA61V

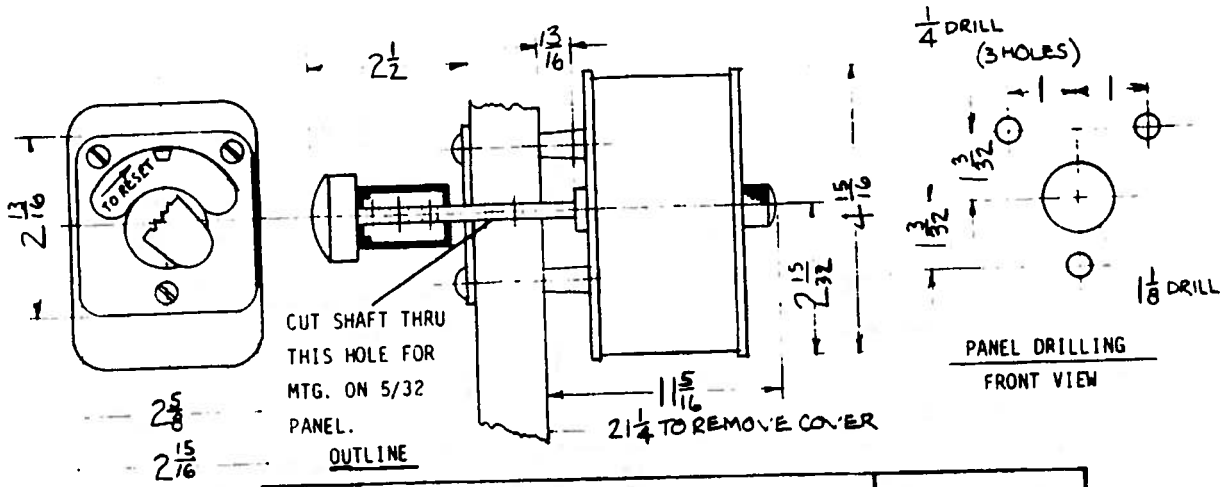

FREQ	RELAY GROUP NUMBERS									CONTACT ARRANGEMENT RESET POSITION	
	DC	DC	DC	DC	DC	DC	DC	DC	DC	OPEN	CLOSED
VOLTS	250	125	48	24	60	32	12	220	275	OPEN	CLOSED
MODEL 0165A0726	210	220	230	240	250	260	270	280	360	NONE	1 TO 6
	211	221	231	241	251	261	271	281	361	1	2 TO 6
	212	222	232	242	252	262	272	282	362	1 & 2	3 TO 6
	213	223	233	243	253	263	273	283	363	1 TO 3	4 TO 6
	214	224	234	244	254	264	274	284	364	1 TO 4	5 TO 6
	215	225	235	245	255	265	275	285	365	1 TO 5	6
	216	226	236	246	256	266	276	286	366	1 TO 6	NONE

HANDLE END OF SWITCH

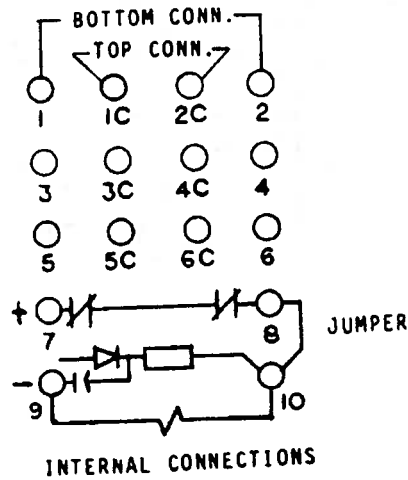

NOTE - CONTACTS 7 & 8 SHOWN IN RESET POSITION

Fig. 11 (0178A7111-4) Outline, Panel Drilling and Internal Connections for HEA62A Relay

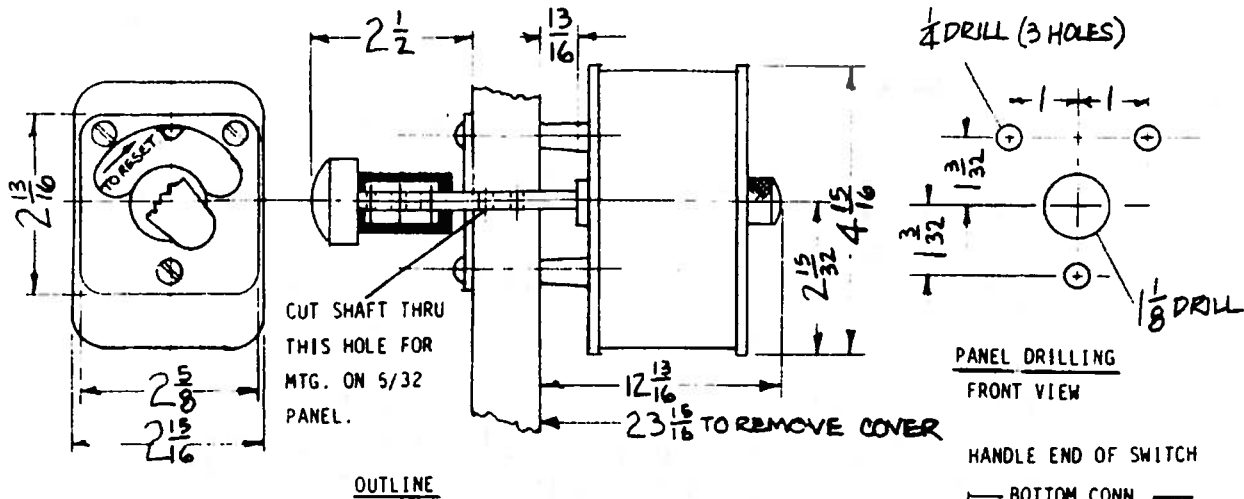

		RELAY GROUP NUMBERS							CONTACT ARRANGEMENT RESET POSITION	
FREQ	DC	DC	DC	DC	DC	DC	DC	DC	OPEN	CLOSED
VOLTS	250	125	48	24	32	230	220	12	OPEN	CLOSED
MODEL 0165A0727	210	230	250	270	290	310	330	430	NONE	1 TO 10
	211	231	251	271	291	311	331	431	1	2 TO 10
	212	232	252	272	292	312	332	432	1 & 2	3 TO 10
	213	233	253	273	293	313	333	433	1 TO 3	4 TO 10
	214	234	254	274	294	314	334	434	1 TO 4	5 TO 10
	215	235	255	275	295	315	335	435	1 TO 5	6 TO 10
	216	236	256	276	296	316	336	436	1 TO 6	7 TO 10
	217	237	257	277	297	317	337	437	1 TO 7	8 TO 10
	218	238	258	278	298	318	338	438	1 TO 8	9 TO 10
	219	239	259	279	299	319	339	439	1 TO 9	10
220	240	260	280	300	320	340	440	1 TO 10	NONE	

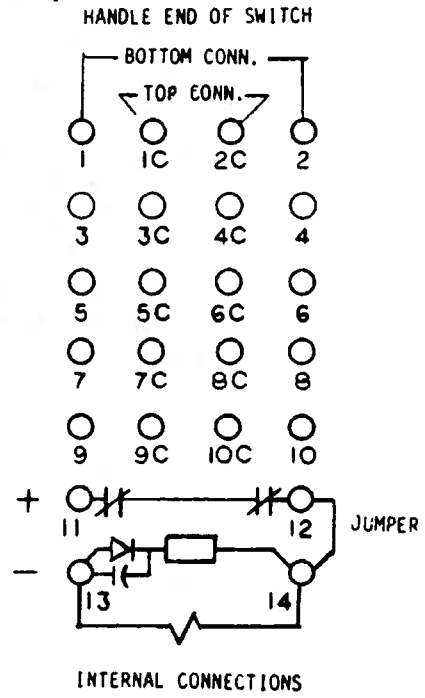

INTERNAL CONNECTIONS
NOTE - CONTACTS 11 & 12 IN RESET POSITION.

Fig. 12 (0178A7112-4) Outline, Panel Drilling and Internal Connections for HEA62B Relay

GEH-2058

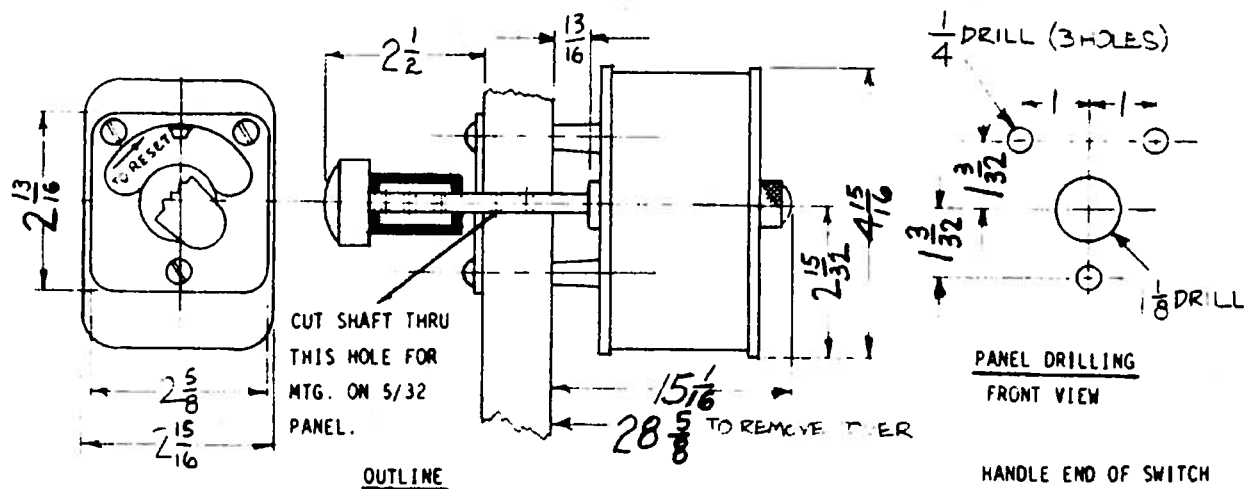

FREQ	RELAY GROUP NUMBERS						CONTACT ARRANGEMENT RESET POSITION	
	DC	DC	DC	DC	DC	DC	OPEN	CLOSED
VOLTS	250	125	48	24	220	275	OPEN	CLOSED
MODEL 0165A0727	210	230	250	270	290	370	NONE	1 TO 16
	211	231	251	271	291	371	1	2 TO 16
	212	232	252	272	292	372	1 & 2	3 TO 16
	213	233	253	273	293	373	1 TO 3	4 TO 16
	214	234	254	274	294	374	1 TO 4	5 TO 16
	215	235	255	275	295	375	1 TO 5	6 TO 16
	216	236	256	276	296	376	1 TO 6	7 TO 16
	217	237	257	277	297	377	1 TO 7	8 TO 16
	218	238	258	278	298	378	1 TO 8	9 TO 16
	219	239	259	279	299	379	1 TO 9	10 TO 16
	220	240	260	280	300	380	1 TO 10	11 TO 16
	221	241	261	281	301	381	1 TO 11	12 TO 16
	222	242	262	282	302	382	1 TO 12	13 TO 16
	223	243	263	283	303	383	1 TO 13	14 TO 16
	224	244	264	284	304	384	1 TO 14	15 TO 16
	225	245	265	285	305	385	1 TO 15	16
226	246	266	286	306	386	1 TO 16	NONE	

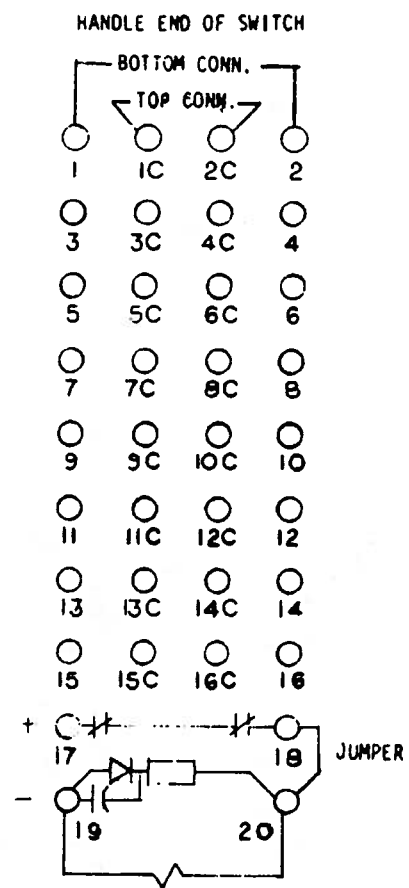

INTERNAL CONNECTIONS

NOTE - CONTACTS 17 & 18 SHOWN IN RESET POSITION.

Fig. 13 (0178A7113-4) Outline, Panel Drilling and Internal Connections for HEA62C Relay

GEH-2058

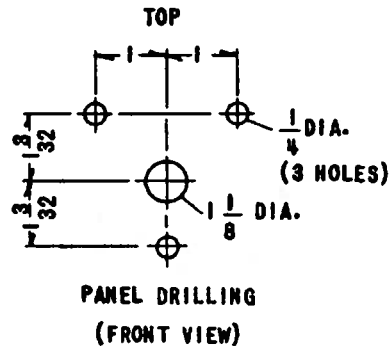
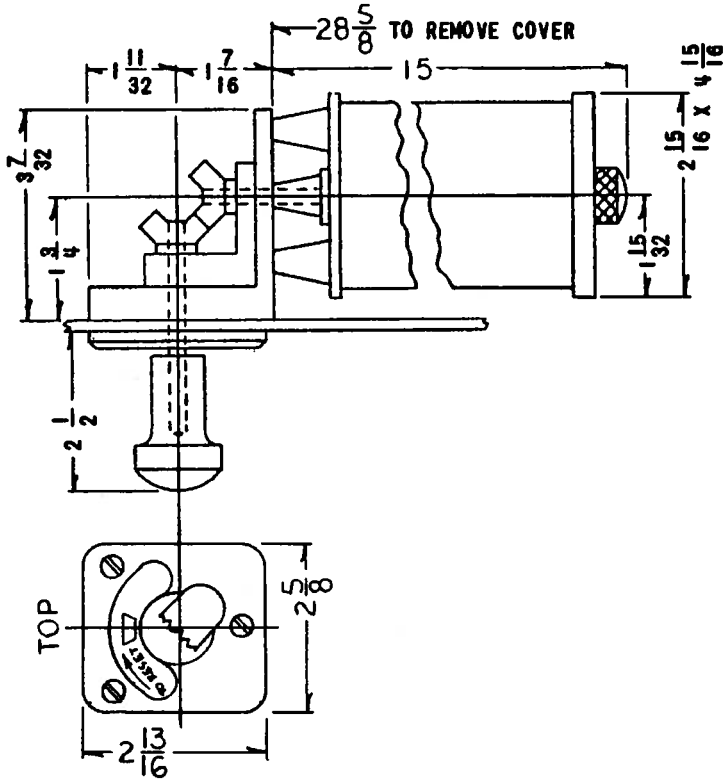

HANDLE END OF SWITCH

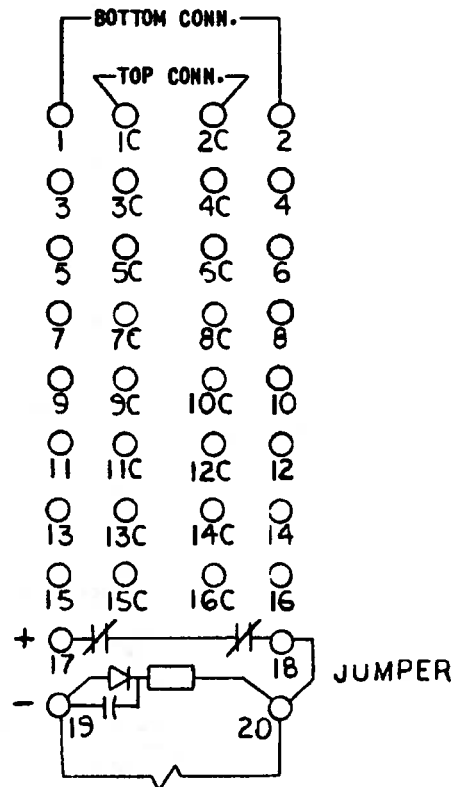

FREQ.	RELAY GROUP NUMBER							CONTACT ARRANGEMENT	
	DC	DC	DC	DC	DC	DC	DC	RESET	POSITION
VOLTS	250	125	48	24	220	275	62.5	OPEN	CLOSED
MODEL 12HEA62CRD	210	230	250	270	290	370	390	NONE	1 TO 16
	211	231	251	271	291	371	391	1	2 TO 16
	212	232	252	272	292	372	392	1 & 2	3 TO 16
	213	233	253	273	293	373	393	1 TO 3	4 TO 16
	214	234	254	274	294	374	394	1 TO 4	5 TO 16
	215	235	255	275	295	375	395	1 TO 5	6 TO 16
	216	236	256	276	296	376	396	1 TO 6	7 TO 16
	217	237	257	277	297	377	397	1 TO 7	8 TO 16
	218	238	258	278	298	378	398	1 TO 8	9 TO 16
	219	239	259	279	299	379	399	1 TO 9	10 TO 16
	220	240	260	280	300	380	400	1 TO 10	11 TO 16
	221	241	261	281	301	381	401	1 TO 11	12 TO 16
	222	242	262	282	302	382	402	1 TO 12	13 TO 16
	223	243	263	283	303	383	403	1 TO 13	14 TO 16
	224	244	264	284	304	384	404	1 TO 14	15 & 16
	225	245	265	285	305	385	405	1 TO 15	16
	226	246	266	286	306	386	406	1 TO 16	NONE

Fig. 13A (0246A2251-1) Outline, Panel Drilling and Internal Connections for Relay HEA62CRD

GEH-2058

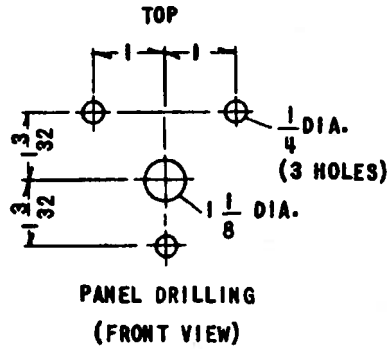
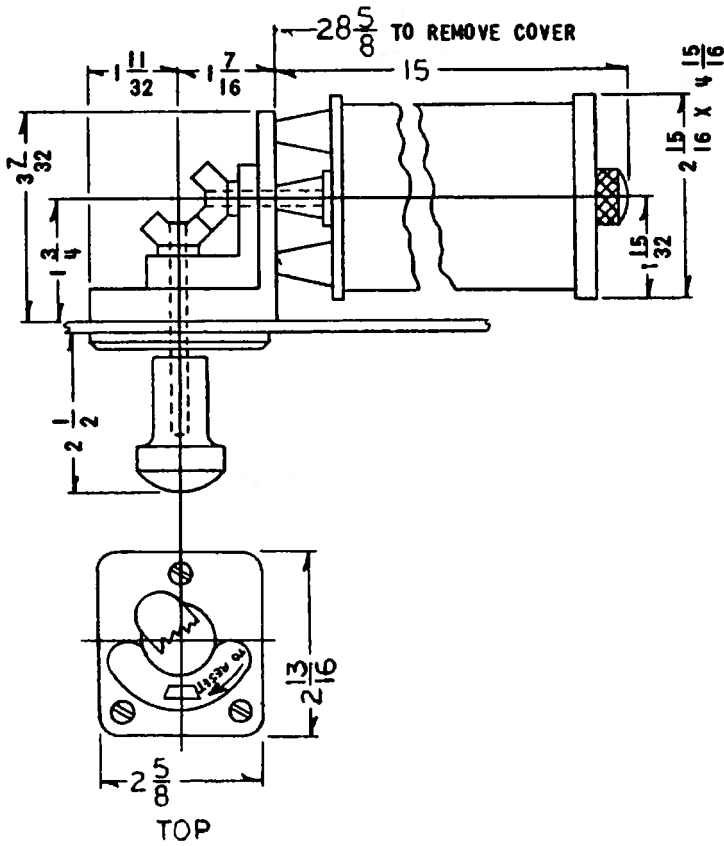

HANDLE END OF SWITCH

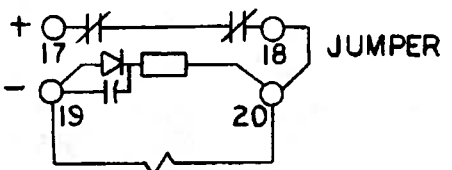
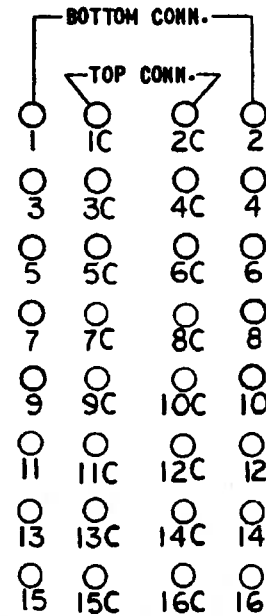

INTERNAL CONNECTIONS
NOTE-CONTACT 17 & 18
SHOWN IN RESET
POSITION

FREQ.	RELAY GROUP NUMBER							CONTACT ARRANGEMENT	
	DC	DC	DC	DC	DC	DC	DC	RESET	POSITION
VOLTS	250	125	48	24	220	275	62.5	OPEN	CLOSED
MODEL 12HEA62CRL	210	230	250	270	290	370	390	NONE	1 TO 16
	211	231	251	271	291	371	391	1	2 TO 16
	212	232	252	272	292	372	392	1 & 2	3 TO 16
	213	233	253	273	293	373	393	1 TO 3	4 TO 16
	214	234	254	274	294	374	394	1 TO 4	5 TO 16
	215	235	255	275	295	375	395	1 TO 5	6 TO 16
	216	236	256	276	296	376	396	1 TO 6	7 TO 16
	217	237	257	277	297	377	397	1 TO 7	8 TO 16
	218	238	258	278	298	378	398	1 TO 8	9 TO 16
	219	239	259	279	299	379	399	1 TO 9	10 TO 16
	220	240	260	280	300	380	400	1 TO 10	11 TO 16
	221	241	261	281	301	381	401	1 TO 11	12 TO 16
	222	242	262	282	302	382	402	1 TO 12	13 TO 16
	223	243	263	283	303	383	403	1 TO 13	14 TO 16
	224	244	264	284	304	384	404	1 TO 14	15 & 16
	225	245	265	285	305	385	405	1 TO 15	16
	226	246	266	286	306	386	406	1 TO 16	NONE

Fig. 13B (0246A2252-1) Outline, Panel Drilling and Internal Connections for Relay HEA62CRL

GEH-2058

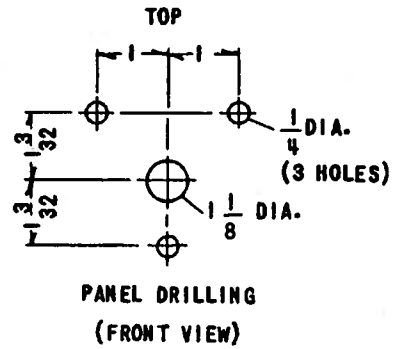
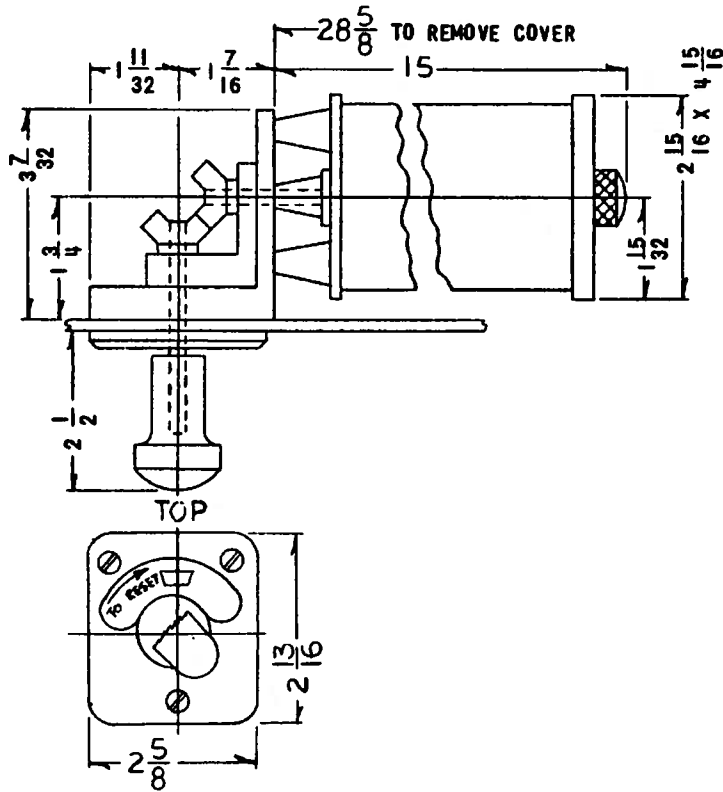

HANDLE END OF SWITCH

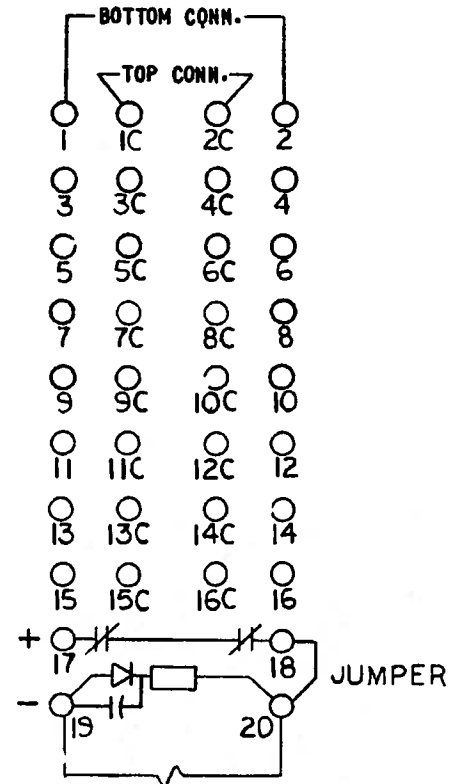

FREQ.	RELAY GROUP NUMBER							CONTACT ARRANGEMENT	
	DC	DC	DC	DC	DC	DC	DC	RESET	POSITION
VOLTS	250	125	48	24	220	275	625	OPEN	CLOSED
MODEL 12HEA62CRR	210	230	250	270	290	370	390	NONE	1 TO 16
	211	231	251	271	291	371	391	1	2 TO 16
	212	232	252	272	292	372	392	1 & 2	3 TO 16
	213	233	253	273	293	373	393	1 TO 3	4 TO 16
	214	234	254	274	294	374	394	1 TO 4	5 TO 16
	215	235	255	275	295	375	395	1 TO 5	6 TO 16
	216	236	256	276	296	376	396	1 TO 6	7 TO 16
	217	237	257	277	297	377	397	1 TO 7	8 TO 16
	218	238	258	278	298	378	398	1 TO 8	9 TO 16
	219	239	259	279	299	379	399	1 TO 9	10 TO 16
	220	240	260	280	300	380	400	1 TO 10	11 TO 16
	221	241	261	281	301	381	401	1 TO 11	12 TO 16
	222	242	262	282	302	382	402	1 TO 12	13 TO 16
	223	243	263	283	303	383	403	1 TO 13	14 TO 16
	224	244	264	284	304	384	404	1 TO 14	15 & 16
	225	245	265	285	305	385	405	1 TO 15	16
226	246	266	286	306	386	406	1 TO 16	NONE	

INTERNAL CONNECTIONS
NOTE-CONTACT 17 & 18
SHOWN IN RESET
POSITION.

Fig. 13C (0246A2253-1) Outline, Panel Drilling and Internal Connections for Relay HEA62CRR

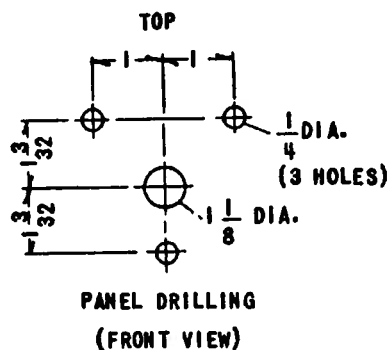
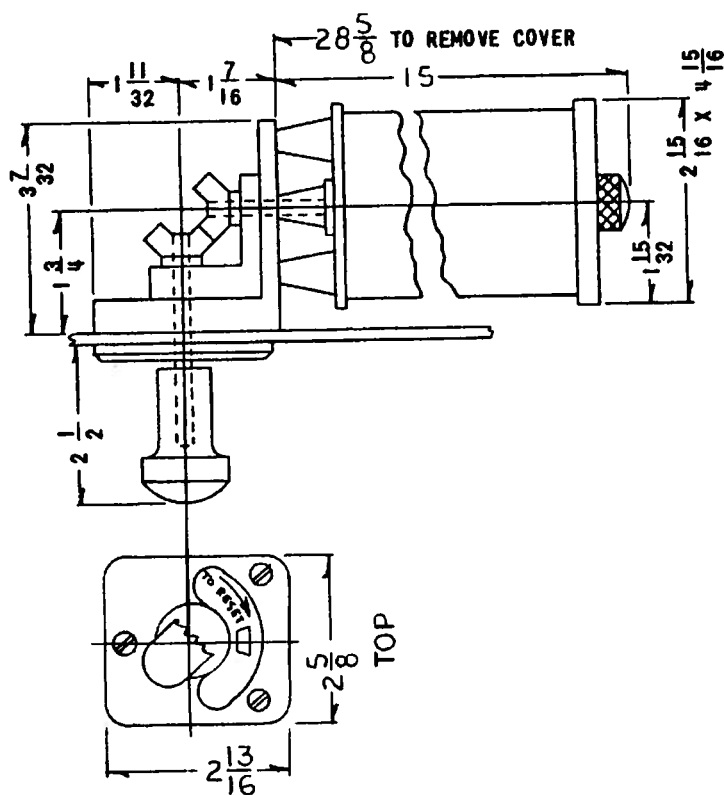

HANDLE END OF SWITCH

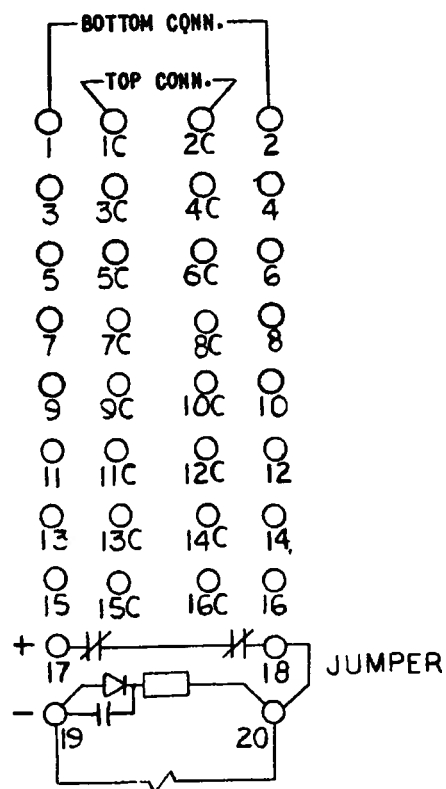

FREQ.	RELAY GROUP NUMBER							CONTACT ARRANGEMENT	
	DC	DC	DC	DC	DC	DC	DC	RESET	POSITION
VOLTS	250	125	48	24	220	275	62.5	OPEN	CLOSED
MODEL 12HEA62CRU	210	230	250	270	290	370	390	NONE	1 TO 16
	211	231	251	271	291	371	391	1	2 TO 16
	212	232	252	272	292	372	392	1 & 2	3 TO 16
	213	233	253	273	293	373	393	1 TO 3	4 TO 16
	214	234	254	274	294	374	394	1 TO 4	5 TO 16
	215	235	255	275	295	375	395	1 TO 5	6 TO 16
	216	236	256	276	296	376	396	1 TO 6	7 TO 16
	217	237	257	277	297	377	397	1 TO 7	8 TO 16
	218	238	258	278	298	378	398	1 TO 8	9 TO 16
	219	239	259	279	299	379	399	1 TO 9	10 TO 16
	220	240	260	280	300	360	400	1 TO 10	11 TO 16
	221	241	261	281	301	361	401	1 TO 11	12 TO 16
	222	242	262	282	302	362	402	1 TO 12	13 TO 16
	223	243	263	283	303	363	403	1 TO 13	14 TO 16
	224	244	264	284	304	364	404	1 TO 14	15 & 16
	225	245	265	285	305	365	405	1 TO 15	16
	226	246	266	286	306	366	406	1 TO 16	NONE

INTERNAL CONNECTIONS
 NOTE-CONTACTS 17 & 18
 SHOWN IN RESET
 POSITION

Fig. 13D (0246A2250-1) Outline, Panel Drilling and Internal Connections for Relay HEA62CRU



GE Power Management

**215 Anderson Avenue
Markham, Ontario
Canada L6E 1B3
Tel: (905) 294-6222
Fax: (905) 201-2098
www.ge.com/indsys/pm**