

GE
Grid Solutions

Reason RT431

GPS Precision-Time Clock



Technical Manual

Platform Hardware Version: B

Platform Software Version: 08

Publication Reference: RT431-TM-EN-HWB-9v3



imagination at work

Contents

Table of Figures	7
List of Tables	9
Chapter 1: Introduction	11
1 Foreword	11
Target Audience	11
Acronyms and abbreviations	11
2 Product Scope	13
3 Key Features	13
PTP / SNTP / NTP	15
Stationary Mode	15
Environmental Robustness	15
4 Functional Overview	16
5 Standards Compliance	16
Chapter 2: Safety Information	17
1 Health and Safety	17
2 Symbols	17
3 Installation, Commissioning and Servicing	18
Lifting Hazards	18
Electrical Hazards	18
Fusing Requirements	20
Equipment Connections	20
Pre-energization Checklist	21
Peripheral Circuitry	22
Upgrading/Servicing	22
4 Decommissioning and Disposal	24
Chapter 3: Hardware Design	25
1 Equipment View	25
2 Network Ports	26
3 Power Supply	26
Chapter 4: Installation	28
1 Unpacking	28
Normal Use of the Equipment	28
External Indications	28
2 Mounting	29
Power Supply	29
Grounding (Earthing)	30
GPS Antenna Terminal	30
TTL Electrical Outputs	32
Open-Collector Electrical Output	33
Serial Port (RS232)	34

3	Ethernet Communication	34
	Factory default settings	34
	Network port and communication protocols	35
	Equipment access	35
4	Powering Up	36
5	Preventive Maintenance Actions	36
	Preventive Actions	36
Chapter 5: Operation		38
<hr/>		
1	Local HMI	38
	Power Indicator	38
	Sync Indicator	38
	Alarm Indicator	38
	Reset Button	38
2	Web Interface (Remote Access)	39
	Web Interface Language	40
3	Monitoring Menus – Web Interface	40
	Status	40
	General Information	41
Chapter 6: Configuration		42
<hr/>		
1	Web Interface	42
	User Name and Password	42
	Sending Configuration	42
2	Ethernet	43
	Ethernet Ports	43
	Default Gateway	43
	DNS Server	43
	Ethernet - Configuration Summary	44
3	Time Settings	44
	Time Parameters	44
	Network Time Protocol (NTP)	45
	Time Settings - Configuration Summary	45
4	Time Signals	46
	Outputs	47
	Serial datagram	48
	Customizable datagrams	48
	Time Signals - Configuration Summary	50
5	PTP Configuration	51
	Comparison between PTP Power Profiles	52
	Profile	53
	Domain number	55
	Network protocol	55
	Operation mode	56
	Delay mechanism	56
	Grandmaster Priority	56
	PTP Messages	56

	PTP - Configuration Summary	57
6	Setup	58
	Configuration Management	60
	Password configuration	60
	Reset Satellites Almanac	60
	Stationary Mode	60
	Demo mode	60
	Log Files	61
	Reboot System	61
	Generate HTTPS Certificate	61
Chapter 7: Maintenance		62
1	Time Synchronization Failure (Locked Signaling)	62
	Sync indicator (HMI)	62
	Remote monitoring (Web Interface)	63
	IRIG-B Signal	63
	PTP Protocol	63
	NTP Protocol	63
	SNTP Protocol	63
2	Firmware Update	63
3	Equipment Upgrade - Key Change	64
4	Cleaning Instructions	65
5	Equipment Return	65
Chapter 8: Technical Specification		67
1	Power Supply	67
2	GPS Antenna	67
	GPS Antenna Receiver	67
	GNSS Antenna Type	68
	Antenna Cable	68
	Surge Arrester	69
3	Internal Oscillator	69
4	Outputs	70
	Connectors	70
	TTL Electrical Outputs	70
	Open Collector Electrical Output	71
	Serial Port (RS232)	71
5	Precision Time Protocol PTP (IEEE 1588)	72
6	Ethernet Port	72
7	Environment	74
8	Type Test	74
9	Dimensions, Weight	77
Chapter 9: Ordering Options		78
1	RT431 Cortec	78
Chapter 10: Appendixes		79

Appendix A – IRIG-B Standard Summary	79
Appendix B – PTP Standard Concepts (IEEE1588)	84
Description	84
Definitions according to IEEE 1588 Standard	84
Hierarchical Topology	85
Multicast and Unicast Networks	85
PTP Synchronization	86
Network protocols	87
Clock operation mode	87
Delay measurement mechanism	87
Master, Slave and Grandmaster clocks	88
PTP Messages	88
Appendix C – Serial Datagrams	90
ACEB Datagrams	90
NEMEA GPZDA Datagram	90
Meinberg Datagram	91
Appendix D – Antenna Delay Compensation	93
Signal Attenuation	93
Propagation Delay	93
Appendix E – Application Examples	95
Application Example 1: Traditional and Modern Time Sync	95
Application Example 2: System Wide Grandmaster Clock	95
Application Example 3: Synchrophasor, TWFL and Process Bus Applications	96
Application Example 4: IEEE 1588 in a PRP Network	97
Application Example 5: Time Sync Expansion using RT411 and RT412	98
Appendix F – Kit Mounting for GNSS Antenna (Q065)	100

Table of Figures

Figure 1: Functional Overview of RT431	16
Figure 2: Front view of RT431	25
Figure 3: View from RT431 connectors	25
Figure 4: Location of Serial number, part number and outputs description.	29
Figure 5: Pre-insulated tubular pin terminals	29
Figure 6: Supply connector assembly	29
Figure 7: RT431 power connection	30
Figure 8: RT431 Grounding Strap	30
Figure 9: GPS antenna connector	31
Figure 10: Recommended position for installing the GNSS Antenna	31
Figure 11: Recommended position GNSS Antenna conduit installation	32
Figure 12: TTL electrical outputs	32
Figure 13: Open collector electrical output	33
Figure 14: Connection diagram of the open-collector electrical outputs	33
Figure 15: Serial port RS232	34
Figure 16: Electrical communication interface via Ethernet network	34
Figure 17: Local HMI from RT431	38
Figure 18: RT431 Web Interface	39
Figure 19: Languages available in the Web Interface	40
Figure 20: Section to monitor the status of the unit in the Web Interface	40
Figure 21: Section to visualize general information of the system	41
Figure 22: Section to configure network parameters of the unit	43
Figure 23: Section to configure time parameters	44
Figure 24: Section to configure time signals applied in the outputs	47
Figure 25: Section to configure PTP parameters	52
Figure 26: Characteristics from PTP Power Profile IEEE C37.238:2017	54
Figure 27: Characteristics from PTP for Power Utility Automation, in accordance with IEC/IEEE 61850-9-3:2016	54
Figure 28: Characteristics from PTP Power Profile IEEE C37.238:2011	55
Figure 29: Setup section in Web Interface	59
Figure 30: Manual Time setting – only available in Demo Mode	61
Figure 31: Section to update firmware	64
Figure 32: Section to equipment upgrade – key change	64

Figure 33: Connectors of RT431	70
Figure 34: RT431 Dimensions	77
Figure 35: Traditional x Modern Time Synchronization	95
Figure 36: System Wide Grandmaster Clock	96
Figure 37: Synchrophasor devices synced by RT430/434	96
Figure 38: TWFL application using RT430/434 for Time Sync	97
Figure 39: Process Bus application using PTP via the Station Bus network.	97
Figure 40: Process Bus application using PTP via the Station Bus network.	98
Figure 41: Time Sync expansion using RT411 and RT412	98
Figure 42: Dimensions of antenna kit mounting	100
Figure 43: Items from antenna kit mounting	101

List of Tables

Table 1: Ethernet port default settings	34
Table 2: Gateway and DNS Server default settings	35
Table 3: Gateway and DNS Server	35
Table 4: Factory default username and password	42
Table 5: Summary of configurable network parameters	44
Table 6: Summary of configurable time parameters	45
Table 7: Customizable datagram special characters	49
Table 8: Summary of all configurable parameters for outputs	50
Table 9: Comparison between PTP Power Profiles	53
Table 10: Summary of configurable PTP parameters	57
Table 11: Power supply specifications	67
Table 12: GPS Antenna input specifications for temporal synchronization	67
Table 13: GNSS Antenna specifications	68
Table 14: Antenna Cable specifications	68
Table 15: Surge arrester specifications	69
Table 16: Internal oscillator specifications	69
Table 17: RT431 connectors	70
Table 18: Electrical outputs specifications	70
Table 19: Open collector outputs specifications	71
Table 20: RS232 serial port specifications	71
Table 21: PTP time synchronization protocol specifications	72
Table 22: Ethernet port specification	72
Table 23: Environment specification	74
Table 24: Enclosure Protection IEC 60529	74
Table 25: EMC tests were performed according to IEC 60255-26 referring to the following standards	74
Table 26: Safety tests	76
Table 27: Environmental tests	76
Table 28: Dimensions and weight specification RT431	77
Table 29: IRIG-B standard summary	79
Table 30: ACEB Datagram Information	90
Table 31: GPZDA Datagram Time Information	91
Table 32: GPZDA Datagram Line Feed and Carriage Return Information	91

Table 33: GPZDA Datagram Checksum Information	91
Table 34: Meinberg Datagram Time Information	92
Table 35: Meinberg Datagram Beginning and End Information	92
Table 36: Meinberg Datagram Locked State Information	92
Table 37: Antenna cables attenuation @ 1500 MHz (± 1 dB)	93
Table 38: Attenuation of antenna cables	94
Table 39: Dimensions specification of antenna kit mounting	100
Table 40: Description of items from kit mounting	100

Reason RT431

GPS Precision-Time Clock

Chapter 1: Introduction

This chapter provides general information about the technical manual and an introduction to RT431 GPS Precision-Time Clocks.

1 Foreword

This technical manual provides a functional and technical description of GE Reason RT43X Precision-Time Clocks, as well as a comprehensive set of instructions for using the devices. The level at which this manual is written assumes that you are already familiar with protection engineering and have experience in this discipline. The description of principles and theory is limited to that which is necessary to understand the product.

We have attempted to make this manual as accurate, comprehensive and user-friendly as possible. However, we cannot guarantee that it is free from errors. Nor can we state that it cannot be improved. We would therefore be very pleased to hear from you if you discover any errors, or have any suggestions for improvement. Our policy is to provide the information necessary to help you safely specify, engineer, install, commission, maintain, and eventually dispose of this product. We consider that this manual provides the necessary information, but if you consider that more details are needed, please contact us.

GE Grid Solutions:
Worldwide Contact Center
Web: www.GEGridSolutions.com/contact
Phone: +44 (0) 1785 250 070

Target Audience

This manual is aimed towards all professionals charged with installing, commissioning, maintaining, troubleshooting, or operating any of the products within the specified product range. This includes installation and commissioning personnel as well as engineers who will be responsible for operating the product.

The level at which this manual is written assumes that installation and commissioning engineers have knowledge of handling electronic equipment. Also, system and protection engineers have a thorough knowledge of protection systems and associated equipment.

Acronyms and abbreviations

AC - Alternating Current;

ASCII - American Standard Code for Information Interchange;
BMC - Best Master Clock;
BNC - Bayonet Neil Councilman connector;
bps - Bits per second;
CAT5 - Network Cable;
CMOS - Complementary Metal-Oxide-Semiconductor;
DB9 - Connector do type D-subminiature;
DC - Direct Current;
DCF77 - Time synchronization protocol Deutschland LORAN-C (Long Range Navigation - C) Frankfurt 77 (77.5 kHz);
DMARK – Single pulse with a programmable date and time;
DNS - Domain Name System;
DST - Daylight Saving Time;
DTE - Data Terminal Equipment;
E2E - End-to-end;
ETH - Abbreviation of the term Ethernet;
FW - Abbreviation of the term Firmware;
GLONASS - GLObal NAVigation Satellite System from Russian Aerospace Defense Forces;
GND - Abbreviation of the term Ground;
GNSS - Global Navigation Satellite System;
GPS - Global Positioning System;
GPZDA - Serial Datagram format;
HTTP - Hypertext Transfer Protocol;
HTTPS - Hypertext Transfer Protocol Secure;
IEC - International Electrotechnical Commission;
IED - Intelligent Electronic Devices;
IEEE - Institute of Electric and Electronic Engineers;
HMI - Human-Machine Interface;
IP - Internet Protocol;
IP40 - Degree of protection 40;
IRIG-B - Time synchronization protocol Inter Range Instrumentation Group (Rate Designation B);
LCD - Liquid Crystal Display;
MAC - Media Access Control;
MIB - Management Information Base;
NTP - Network Time Protocol;
OUT - Abbreviation of the term Output;
P2P - Peer-to-peer;
PPM - Pulse per minute;
PRP - Parallel Redundancy Protocol;
PPS - Pulse per Second;
PPX - Pulse per X s;
PTP - Precision Time Protocol;
RAIM - Receiver Autonomous Integrity Monitoring;
RJ45 - Ethernet Connector with 8 conductors;
RS232/485 - Serial port levels;
RX - Receiving data;
SNMP - Simple Network Management Protocol;
SNTP - Simple Network Time Protocol;
ST - Bayonet-lock connector;
TCP - Transmission Control Protocol;

TMARK - Daily pulses with programmable time;
TTL - Transistor-to-Transistor logic;
TX - Data transmission;
UDP - User Datagram Protocol;
UTC - Universal Time Coordinate.

2 Product Scope

Reason RT431 is a compact GPS-based clock designed to be installed on a DIN rail, allowing the equipment to be installed in locations with limited space and reduced panels.

The RT431 is ruggedized and specifically designed for operation and to be part of the large scale electrical fixed installations, as electrical power generation installations, electrical substations and electrical utilities control systems.

With nanosecond time accuracy, the RT431 provides temporal synchronization for applications as synchrophasor measurement, traveling wave fault location, current differential protection operating over SONET and MPLS systems, and others.

The time synchronization protocols supported are:

- PTP (Precision Time Protocol) according to IEEE 1588v2:2008;
- Operates as a PTP master clock or ordinary clock;
- PTP Power Profile, in accordance with latest IEEE C37.238:2017 and its previous 2011 version;
- PTP Profile for Power Utility Automation, in accordance with IEC 61850-9-3:2016 standard;
- NTP/SNTP;
- IRIG-B004 (Demodulated);
- DCF77;
- Serial Datagram;
- Low frequency pulses, as PPS, PPM and others configurable options.

Configured as PTP slave, RT431 may also act as a PTP translator, converting PTP messages to IRIG-B, serial or pulse time codes, enabling the use of legacy equipment in architectures where PTP is used.

3 Key Features

- Better than 100ns time accuracy;
- IEEE 1588v2 PTP protocol;
- PTP Profile for Power Utility Automation, in accordance with IEC 61850-9-3:2016 standard;
- PTP Power Profile, in accordance with latest IEEE C37.238:2017 and its previous 2011 version;
- NTP/SNTP time server;
- PTP and NTP/SNTP simultaneously through Ethernet port;
- Status monitoring using SNMP (v1, v2c and v3), including MIB support;
- Stationary Mode to keep a locked synchronization even with only one satellite;
- Delay compensation for GPS antenna cables;

- Time signals in IRIG-B004 or DCF77 format;
- Pulses: 100 pulses-per-second, 1 pulse-per-second, 1 pulse-per-minute;
- Freely configurable low frequency pulse generator;
- Pulse on-time with daily repetition;
- User-configurable rules for daylight-saving-time and configurable time zone;
- Web Interface for configuring and monitoring, available in five different languages: English, French, Spanish, Portuguese and Russian
- RS232 serial port for datagram;
- Ethernet network port 10/100Base-T for configuration and access to the equipment;
- Indicators for monitoring synchronization of GPS antenna and equipment status;
- DIN Rail mounting
- Full range power supply;

PTP / SNTP / NTP

The Reason RT431 offers the accurate PTP time protocol, which is defined by the IEEE 1588 standard, to precisely synchronize IED's and computers over a LAN (or VLAN). Besides, using PTP is a great solution to synchronize multiple clocks with a better than 100ns time accuracy over Ethernet networks.

As designed by the IEEE 1588, RT431 may operate either as the "PTP Grandmaster" clock or "Slave" clock. For power applications, Reason clocks support both the PTP Power Profile (IEEE C37.238:2011/2017) and the PTP Profile for Power Utility Automation (IEC 61850-9-2:2016).

To save time and reduce costs by avoiding the need to overlay a separate time-synchronizing network, SNTP/NTP and PTP can share the same physical links as IEC 61850, DNP3 over Ethernet, MODBUS, etc.

Stationary Mode

In mostly applications, the equipment providing the time synchronization must be in locked state. For this reason, the Stationary Mode allows the equipment to be in a locked state even when receiving signals from a single satellite.

However, these two conditions are necessary to use the Stationary Mode:

- Stationary Mode can be used only when RT431 is in a fixed position (in a substation, for example). If the unit is moved from its position when operation in Stationary Mode, there will be loss of time accuracy.
- Before operating in Stationary Mode, RT431 must lock its sync receiving information from at least four satellites. This condition applies every time the unit is powered on.

Environmental Robustness

With a robust design, RT431 is in accordance with IEC 61010-1 standard, ensuring reliability and ruggedness even under harsh environments. Every manufactured unit undergoes complete functional and stress tests to ensure the highest quality.

4 Functional Overview

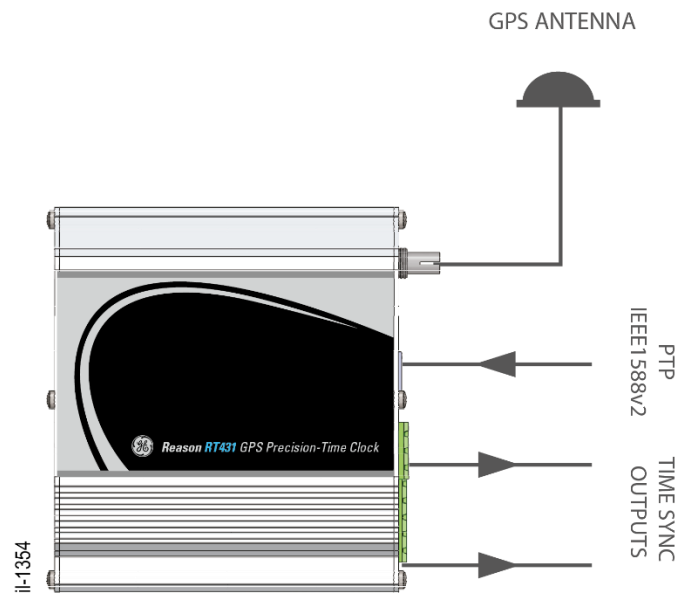

Figure 1: Functional Overview of RT431

5 Standards Compliance

The device has undergone a range of extensive testing and certification processes to ensure and prove compatibility with all target markets. A detailed description of these criteria can be found in the Technical Specifications chapter.

Compliance with the European Commission Directive and UK Conformity Assessed on EMC and LVD is demonstrated by self-certification against international standards.



- EMC Compliance: Compliance with IEC 60255-26:2013 was used to establish conformity.
- Product Safety: Compliance with IEC 61010-1:2010 was used to establish conformity.
- Protective Class: Protective Class I. This equipment requires a protective conductor (ground) to ensure user safety.
- Installation category: Compliance with IEC 61010-1:2010 Overvoltage Category II
- Environment: IEC 60068-2-1, IEC 60068-2-2, IEC 60068-2-30, IEC 60068-2-14, IEC 60255-21-1, IEC 60255-21-2. The equipment is intended for indoor use only. If it is required for use in an outdoor environment, it must be mounted in a specific cabinet or housing which will enable it to meet the requirements of IEC 60529 with the classification of degree of protection IP20.
- R&TTE Compliance: Radio and Telecommunications Terminal Equipment (R&TTE) directive 99/5/EC. Conformity is demonstrated by compliance to both the EMC directive and the Low Voltage directive, to zero volts.

Reason RT431

GPS Precision-Time Clock

Chapter 2: Safety Information

This chapter provides information about the safe handling of the equipment. The equipment must be properly installed and handled in order to maintain it in a safe condition and to keep personnel safe at all times. You must be familiar with information contained in this chapter before unpacking, installing, commissioning, or servicing the equipment.

1 Health and Safety

Personnel associated with the equipment must be familiar with the contents of this Safety Information.

When electrical equipment is in operation, dangerous voltages are present in certain parts of the equipment. Improper use of the equipment and failure to observe warning notices will endanger personnel.

Only qualified personnel may work on or operate the equipment. Qualified personnel are individuals who are:

- Familiar with the installation, commissioning, and operation of the equipment and the system to which it is being connected.
- Familiar with accepted safety engineering practices and are authorized to energize and de-energize equipment in the correct manner.
- Trained in the care and use of safety apparatus in accordance with safety engineering practices
- Trained in emergency procedures (first aid).

The documentation provides instructions for installing, commissioning and operating the equipment. It cannot, however cover all conceivable circumstances. In the event of questions or problems, do not take any action without proper authorization. Please contact your local sales office and request the necessary information.

Each product is subjected to routine production testing for Dielectric Strength and Protective Bonding Continuity.

2 Symbols

Throughout this manual you will come across the following symbols. You will also see these symbols on parts of the equipment.



Caution: Refer to equipment documentation. Failure to do so could result in damage to the equipment



Risk of electric shock



Ground terminal. Note: This symbol may also be used for a protective conductor (ground) terminal if that terminal is part of a terminal block or sub-assembly.



Protective conductor (ground) terminal



Both direct and alternating current



Instructions on disposal requirements

The term 'Ground' used in this manual is the direct equivalent of the European term 'Earth'.

3 Installation, Commissioning and Servicing

Lifting Hazards

Many injuries are caused by:

- Lifting heavy objects
- Lifting incorrectly
- Pushing or pulling heavy objects
- Using the same muscles repetitively

Plan carefully, identify any possible hazards and determine how best to move the product. Look at other ways of moving the load to avoid manual handling. Use the correct lifting techniques and Personal Protective Equipment (PPE) to reduce the risk of injury.

Electrical Hazards



All personnel involved in installing, commissioning, or servicing this equipment must be familiar with the correct working procedures.



Consult the equipment documentation before installing, commissioning, or servicing the equipment.



Always use the equipment as specified. Failure to do so will jeopardize the protection provided by the equipment.



Removal of equipment panels or covers may expose hazardous live parts. Do not touch until the electrical power is removed. Take care when there is unlocked access to the rear of the equipment.



Isolate the equipment before working on the terminal strips.



Use a suitable protective barrier for areas with restricted space, where there is a risk of electric shock due to exposed terminals.



Disconnect power before disassembling. Disassembly of the equipment may expose sensitive electronic circuitry. Take suitable precautions against electrostatic voltage discharge (ESD) to avoid damage to the equipment.



NEVER look into optical fibers or optical output connections. Always use optical power meters to determine operation or signal level.



Testing may leave capacitors charged to dangerous voltage levels. Discharge capacitors by reducing test voltages to zero before disconnecting test leads.



If the equipment is used in a manner not specified by the manufacturer, the protection provided by the equipment may be impaired.



Operate the equipment within the specified electrical and environmental limits.



Before cleaning the equipment, ensure that no connections are energized. Use a lint free cloth dampened with clean water.



Integration of the equipment into systems shall not interfere with its normal functioning.



The functioning of the device has been certified under the circumstances described by the standards mentioned. Usage of the equipment in different conditions from the specified in this manual might affect negatively its normal integrity.



The equipment shall have all their rear connectors attached even if they are not being used, in order to keep their levels of ingress protection as high as possible



Never manipulate liquid containers near the equipment even when it is powered off.



Avoid modification to the wiring of panel when the system is running.

Fusing Requirements



A high rupture capacity (HRC) fuse type with a maximum current rating of 10 Amps and a minimum dc rating of 250 V dc may be used for the auxiliary supply (for example Red Spot type NIT or TIA). Alternatively, a miniature circuit breaker (MCB) of type C, 10 A rating, compliant with IEC 60947-2 may be used.



Reason devices contain an internal fuse for the power supply, which is only accessed by opening the product. This does not remove the requirement for external fusing or use of an MCB as previously mentioned. The ratings of the internal fuses are 2 Amp, type T, 250V.

Equipment Connections



Terminals exposed during installation, commissioning and maintenance may present a hazardous voltage unless the equipment is electrically isolated.



Tighten M3 clamping screws of heavy-duty terminal block connectors to a nominal torque of 1.0Nm. Tighten captive screws of header-type (Euro) terminal blocks to 0.5 Nm minimum and 0.6 Nm maximum.



Be careful, does not apply external voltage to TTL and Serial outputs at the risk of causing irreversible damage to the equipment.



Be careful when installing the antenna cable to RT43X. The cable may be too heavy to be supported by the antenna input connector only, damaging the equipment. Make sure the cable antenna is fixed in the rack (or other support) to minimize the weight load in the antenna input connector from RT43X.



Always use insulated crimp terminations for voltage and current connections.



Always use the correct crimp terminal and tool according to the wire size.



In order to maintain the equipment's requirements for protection against electric shock, other devices connected to the equipment shall have protective class equal or superior to Class I.



Ground the equipment with the supplied PCT (Protective Conductor Terminal).



Do not remove the PCT.



The PCT is sometimes used to terminate cable screens. Always check the PCT's integrity after adding or removing such ground connections.



The user is responsible for ensuring the integrity of any protective conductor connections before carrying out any other actions.



The PCT connection must have low-inductance and be as short as possible. For best EMC performance, ground the unit using a 10 mm (0.4 inch) wide braided grounding strap.



All connections to the equipment must have a defined potential. Connections that are pre-wired, but not used, should be grounded, or connected to a common grouped potential.



Pay extra attention to diagrams before wiring the equipment. Always be sure that the connections are correct before energizing the circuits.

Pre-energization Checklist



Check voltage rating/polarity (rating label/equipment documentation).



Check protective fuse or miniature circuit breaker (MCB) rating.



Check integrity of the PCT connection.



Check voltage and current rating of external wiring, ensuring it is appropriate for the application.

Peripheral Circuitry



Where external components such as resistors or voltage dependent resistors (VDRs) are used, these may present a risk of electric shock or burns if touched.



Operation of computers and equipment connected to RT43x under environmental conditions such as temperature and humidity that exceed the conditions specified in their respective manuals can cause malfunctioning or even irreversible damage to them or the nearby installation.



There might be situations in which the unit is operating within its environmental operational range, but the computers, equipment connected to them or nearby equipment are operating outside their operational range. That situation can cause malfunctioning and/or irreversible damage to those devices. In that occasion the communication to the Reason equipment might be compromised but its operational and safety capacities will not be affected.

Upgrading/Serviceing



Do not insert or withdraw modules, PCBs or expansion boards from the equipment while energized, as this may result in damage to the equipment. Hazardous live voltages would also be exposed, endangering personnel.



Internal modules and assemblies can be heavy and may have sharp edges. Take care when inserting or removing modules into or out of the IED.

4 Decommissioning and Disposal



Before decommissioning, completely isolate the equipment power supply (both poles of any dc supply). The auxiliary supply input may have capacitors in parallel, which may still be charged. To avoid electric shock, discharge the capacitors using the external terminals before decommissioning.



Avoid incineration or disposal to water courses. Dispose of the equipment in a safe, responsible and environmentally friendly manner, and if applicable, in accordance with country-specific regulations.

Reason RT431

GPS Precision-Time Clock

Chapter 3: Hardware Design

This chapter demonstrates the main hardware characteristics from RT431

1 Equipment View

With a compact design, all the equipment connections can be access by one side.

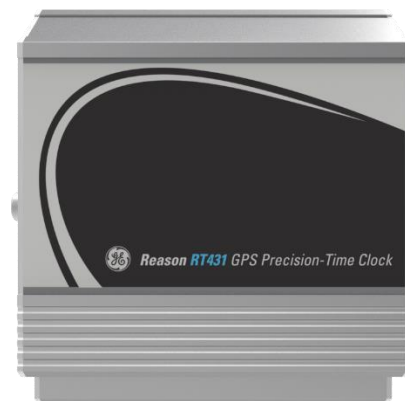

Figure 2: Front view of RT431

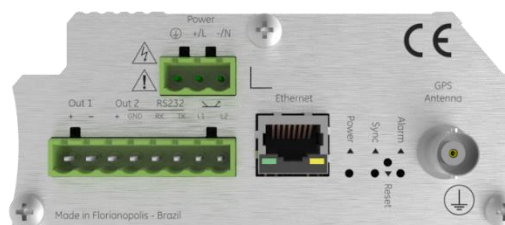

Figure 3: View from RT431 connectors

The RT431 comprises:

- One power supply, AC/DC high voltage;
- Two TTL electrical outputs for synchronization;
- One open collector output;
- One RS232 serial port;
- One Ethernet network communication port;
- GPS antenna input.

The SYNC indicator shows if the equipment is synchronized with time reference from GPS satellites or from a PTP Grandmaster Clock. When the ALARM indicator is on, the equipment is not operating and it is necessary the operator's attention. The POWER led indicates the equipment is on.

2 Network Ports

The network interface presents the following features depending on the equipment version:

1. Monitoring and configuration;
2. NTP/SNTP synchronization protocols;
3. IEEE 1588 PTP synchronization protocol.

3 Power Supply

The power supply has the following nominal voltages: 100-240Vac, 110-250Vdc;

Reason RT431

GPS Precision-Time Clock

Chapter 4: Installation

The RT431 is ruggedized and specifically designed for operation and to be part of the large scale electrical fixed installations, as electrical power generation installations, electrical substations and electrical utilities control systems.

1 Unpacking

Unpack the unit carefully and make sure all the accessories and cables are put aside so they will not be lost.

Check the contents against the packing list that goes with the product. If any of the content listed is missing, please contact GE Grid Solutions (see contact information in Maintenance chapter).

Examine the unit for any shipping damage. If the unit is damaged or fails to operate, notify the shipping company without delay. Only the consignee (the person or company receiving the unity) can file a claim against the carrier for shipping damage.

We recommend you to keep the original packing materials for possible transport in the future.

Normal Use of the Equipment

In order to maintain the equipment integrity, levels of protection and assure user safety, the RT431 must be installed in an enclosed panel with recommended ingress protection rating of IP54 or above.

The enclosing panel must ensure that the equipment is unexposed and protected against impact and water, whilst maintaining adequate temperature and humidity condition for the devices. Furthermore, the equipment must have all their connectors attached, even if not being used, to keep their levels of ingress protection as high as possible.

External Indications

Connector descriptions, serial number and part number are shown on an external label positioned on the equipment, as illustrated on below.

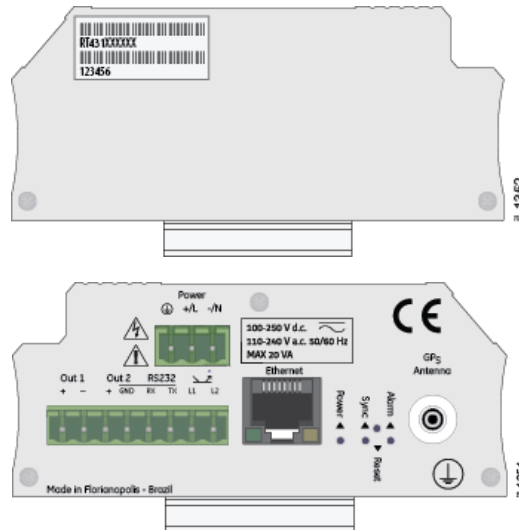

Figure 4: Location of Serial number, part number and outputs description.

2 Mounting

RT431 has been designed to be mounted in a standard DIN-rail. Allow adequate clearance for all connections.

For more information regarding the equipment dimensions, refer to the Technical Specification chapter.

Power Supply

The unit can be powered from a DC or AC power supply within the limits specified. The power connections must use insulated flameproof flexible cable with a 1.5 mm² cross section, 70 °C thermal class, and 750 V insulation voltage.

To reduce the risk of electrical shock, pre-insulated tubular pin terminals should be used on the ends of the power connections.

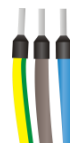

Figure 5: Pre-insulated tubular pin terminals

The pin terminals must be completely inserted into the connector supplied with the unit so that no metallic parts are exposed, according to the figure below.

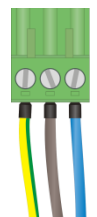

Figure 6: Supply connector assembly

A 1.5 mm² ground lead must be connected to the terminal marked with the protective ground symbol for safety.

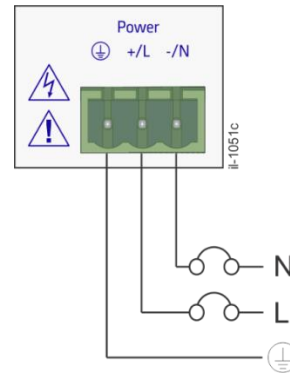

Figure 7: RT431 power connection

For AC power connection, the phase conductor must be applied to terminal (+/L), neutral conductor to terminal (-/N) in the supply terminals identified as illustrated below.

For DC power connection, the positive line should be applied to terminal (+/L), negative to terminal (-/N) in the supply terminals identified as illustrated below.

For compliance with IEC 61010, install a suitable external switch or circuit breaker in each current-carrying conductor of RT431 power supply; this device must interrupt both the hot (+/L) and neutral (-/N) power leads. An external 10 A, category C, bipolar circuit-breaker is recommended. The circuit breaker should have an interruption capacity of at least 25 kA and comply with IEC 60947-2. The switch or circuit-breaker must be suitably located and easily reachable, also it must not interrupt the protective ground conductor.

Grounding (Earthing)

To ensure proper operation of the equipment under extreme electromagnetic conditions, connect the equipment protective ground terminal to the panel using a copper strap of at least 10 mm width as M6 ring lug.

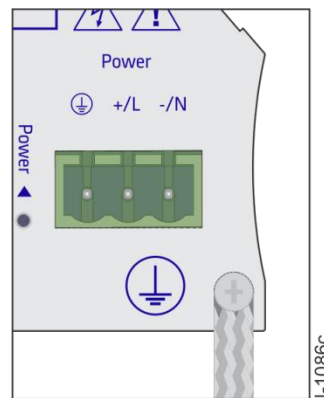

Figure 8: RT431 Grounding Strap

GPS Antenna Terminal

A 3.3-Volt active GPS antenna (100 mA max loading) must be connected to the antenna input terminal when satellites are being used as time reference.

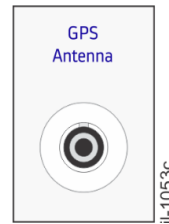

Figure 9: GPS antenna connector

If the GPS antenna is connected and it is possible to receive signal from at least 4 satellites the LOCKED indicator will start to blink after a couple of seconds, indicating that the internal time-base is being synchronized with the satellites. The LOCKED indicator will stop blinking and will remain lit as soon as maximum accuracy is achieved. This process may take several minutes if the equipment was transported for more than a few hundred kilometers or was unpowered for many weeks.

The antenna must be mounted outdoors, in a vertical position, with an unobstructed view of the sky. The antenna should be placed above the height of the building as much as possible. A partially obstructed sky view will compromise the unit's performance.

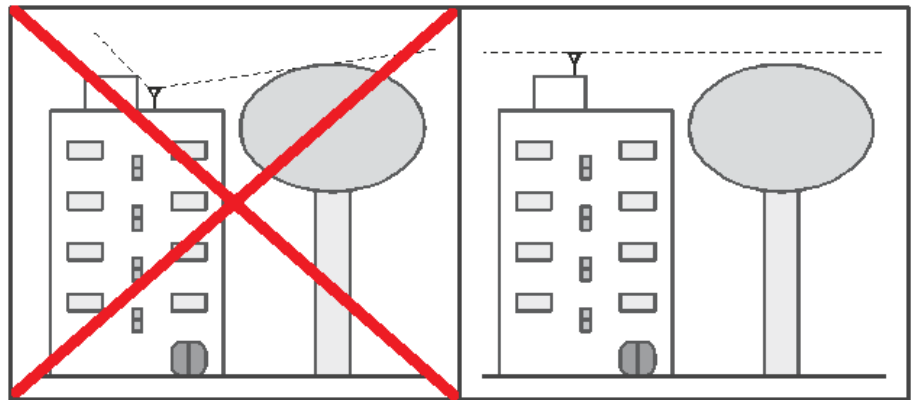

Figure 10: Recommended position for installing the GNSS Antenna

The antenna should not be located under overhead power lines or other electric light or power circuits, or from where it can fall onto such power lines or circuits.

An antenna mast or roof-mounting-kit and any supporting structure must be properly grounded to provide protection against voltage surges and built-up static charges. It is recommended the use of a surge arrester for the entire wiring where there is external antenna cabling.

The antenna must be connected to the unit by using a coaxial cable with a 50 Ω impedance. The antenna cable should be routed through a conduit, shielded from rain and/or solar radiation. The conduit should not be shared with any power circuits. It is recommended to use a 3/4" PVC conduit, threaded on one end. To install it, cut down to the intended size and screw the antenna in the conduit. The conduit can be fixed on the wall, so that the antenna is above the wall limit and free from lateral obstacles, as shown in the next figure.

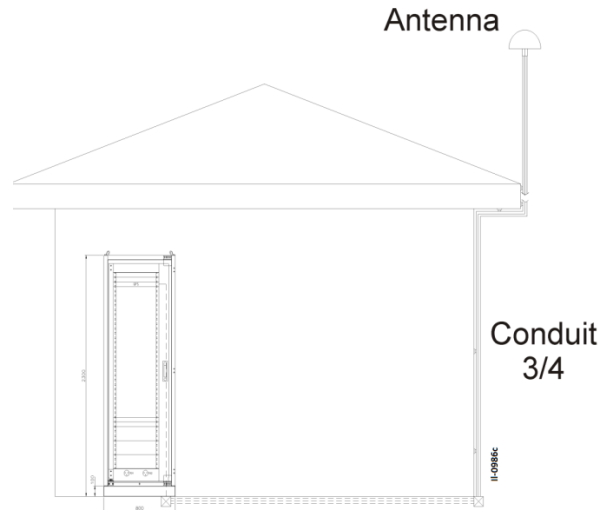

Figure 11: Recommended position GNSS Antenna conduit installation

Cables with lengths ranging from 15 m (50 ft) to 150 m (492 ft) can be ordered from GE Grid Solutions. Be careful when installing the antenna cable to RT43X. The cable may be too heavy to be supported by the antenna input connector only, damaging the equipment. Make sure the cable antenna is fixed in the rack (or other support) to minimize the weight load in the antenna input connector from RT43X.

For use of antennas and cables from other manufacturers, contact GE Grid Solutions for evaluation.

The antenna cable affects the unit's performance in two distinct ways: satellite signal attenuation and propagation delay.

TTL Electrical Outputs

RT431 has two electrical outputs with screw connectors, being one of them insulated. The type of signal at each output can be configured through a Web Interface to generate IRIG-B004, DCF77, 1PPS, 1PPM, 100PPS, or any custom-defined low frequency, from 1 pulse-every-two-seconds to 1 pulse-per-day. In addition, it is possible to configure the outputs to generate daily set-time pulses. The polarity of the signal and the pulse width can also be configured.

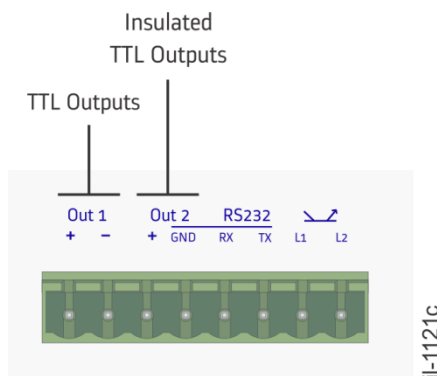

Figure 12: TTL electrical outputs

More than one device can be connected in parallel from one TTL output. The maximum number of devices that can be connected to the TTL output depends on the current that

each device’s input uses. As the maximum current supplied from each TTL output is 150mA, the sum of the currents from all devices connected cannot exceed this value (cable resistance should be considered). The TTL voltage level is 5V. Electrical cable length should not exceed 100m. To minimize EMC effects in IRIG-B signals, the use of fiber-optic cable is recommended for distances greater than 3 m. For details on the configuration of TTL-Level electrical outputs, refer to the Configuration chapter. See the Technical Specification chapter for more description of signal levels and maximum ratings.

Open-Collector Electrical Output

The unit has 1 open-collector electrical output, available for customized time synchronization with DC level. The electrical cable length should not exceed 100m. The type of signal at the output can be configured through a Web Interface to generate IRIG-B004, DCF77, 1PPS, 1PPM, 100PPS, or any custom-defined low frequency, from 1 pulse-every-two-seconds to 1 pulse-per-day. In addition, it is possible to configure the output to generate daily set-time pulses. The polarity of the signal and the pulse width can also be configured.

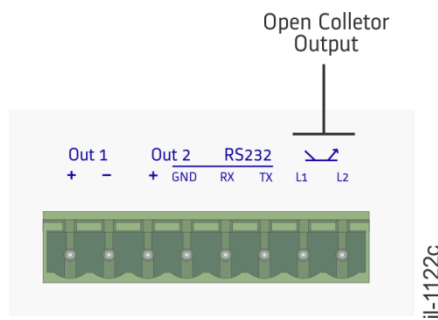

Figure 13: Open collector electrical output

The open-collector output requires the use of an external resistor properly sized to limit current to a value below 300 mA.

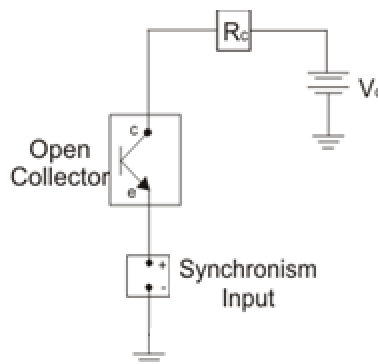

Figure 14: Connection diagram of the open-collector electrical outputs

To scale the resistor use the relationship:

$$R_c \geq \frac{V_c}{0.3}$$

Where V_c is the external DC voltage to be switched by the open-collector output.

The resistor power should be adequate for the voltage and current values to be switched, i.e.

$$P_c \geq 1.2 \cdot \frac{V_c^2}{R_c}$$

Do not connect the open-collector electrical outputs without a properly sized external resistor or another appropriate mechanism to limit current.

See the Technical Specification chapter for a description of signal levels and maximum ratings.

Serial Port (RS232)

The RT431 offers a RS232 serial port for datagram messages.

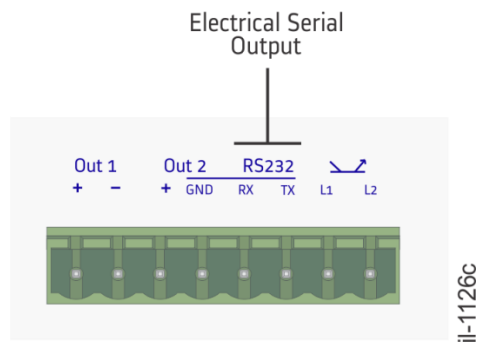

Figure 15: Serial port RS232

For serial port configuration, see the Configuration chapter.
 For existing datagrams details, see Appendix.

3 Ethernet Communication

The RT431 has one RJ45 Ethernet 10/100BaseT communication port with auto-negotiation.

When a CAT5 cable with RJ45 connector is plugged in each port, the LINK led will indicate that the cable is transmitting signal, and the ACTIVITY led blinks when there is data exchange.

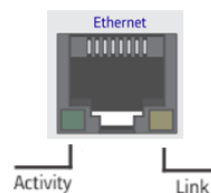

Figure 16: Electrical communication interface via Ethernet network

Factory default settings

Table 1: Ethernet port default settings

IP Address	192.168.0.199
------------	---------------

Netmask	255.255.255.0
Broadcast	192.168.0.255

The factory default settings of the Gateway and DNS Server are:

Table 2: Gateway and DNS Server default settings

Gateway (Ethernet 1)	192.168.0.254
Server DNS	192.168.0.254

The Ethernet parameters can be configured through the Web Interface.

Network port and communication protocols

To ensure unrestricted access to communication via Ethernet network, the following ports and protocols should be enabled:

Table 3: Gateway and DNS Server

Port	Protocol	Description
80	TCP/IP	Remote access via Web
123	UDP	NTP/SNTP Time synchronization
161	UDP	SNMP for equipment monitoring
319	UDP	Sending event messages PTP to synchronize
320	UDP	Sending general messages via PTP to synchronize
443	HTTPS	Establishing a safe connection via Web interface

Equipment access

The Web Interface is designed for configuring and monitoring the unit through a web browser, if the unit it is accessible from a local network. To use all features through the Web Interface, make sure to use one of the following web browsers:

- Internet Explorer version 7.0 or newer.
- Mozilla Firefox version 3.0 or newer.
- Google Chrome

Connect to the Web Interface by entering the unit IP address into the address field of your web browser. After the page is loaded, the unit's Web Interface will open, allowing the user to operate, monitor, and configure it.

4 Powering Up

Before energizing the unit, familiarize yourself with all the risks and attention indicators in the equipment frame.

- Connect the power supply (including the ground lead) to the appropriate terminals.
- The unit will perform a self-test procedure, and the Alarm indicator will remain lit.
- At the end of the self-test, the equipment will perform initialization of the GPS receiver. At the end of approximately one minute, the Alarm indicator will go out. If Alarm indicator remains on, the unit will not be operating and it will require attention by the user.
- To turn off the unit, switch off the external switch or circuit breaker. The unit will record the time, date, satellite orbits parameters, and internal oscillators drift estimates in non-volatile memory to improve accuracy and reduce the time to synchronize with satellites in the next energizing process. Also, all indicators LEDs will turn off.

In case the unit does not behave in a way here described, carefully check all power and signal connections. See Maintenance chapter for additional suggestion for problem diagnosis.

5 Preventive Maintenance Actions

In view of the critical nature of the application, GE products should be checked at regular intervals to confirm they are operating correctly. GE products are designed for a life in excess of 20 years.

The devices are self-supervising and so require less maintenance than earlier designs of protection devices. Most problems will result in an alarm, indicating that remedial action should be taken. However, some periodic tests should be carried out to ensure that they are functioning correctly and that the external wiring is intact.

It is the responsibility of the customer to define the interval between maintenance periods. If your organization has a Preventative Maintenance Policy, the recommended product checks should be included in the regular program. Maintenance periods depend on many factors, such as:

- The operating environment;
- The accessibility of the site;
- The amount of available manpower;
- The importance of the installation in the power system;
- The consequences of failure.

Preventive Actions

For optimum performance of Reason RT431, perform the following preventive maintenance procedures and actions:

Keep temperature and humidity at adequate levels inside the panel. The American Society of Heating, Refrigerating, and Air Conditioning Engineers (ASHRAE) recommends operating network equipment within the following ranges of temperature and relative humidity (see the ASSHRAE TC9.9 “2011 Thermal Guidelines for Data Processing Environments – Expanded Data Center Classes and Usage Guidance”).

- Temperature within 18° C to 27° C (64.4° F to 80.6° F)
- Relative humidity less than 60%
- Dew point within the range of 5.5° C to 15° C (41.9° F to 59.0° F)

Operating within this range supports the highest degree of equipment reliability, even though the equipment data sheets may state wider ranges of minimum and maximum temperature and humidity (for example, -40° C to 55° C and 5% to 95% RH). Continuous equipment operation at the minimum and maximum limits is not recommended.

Keep panel sealed to avoid dust and/or animals and insects.

Inspect the installation site for moisture, loose wires or cables, and excessive dust.

Make sure that airflow is unobstructed around the device and into the air intake vents.

It is recommended weekly or every two weeks to access the web interface area of the unit and check the equipment details in Status area. See Operation chapter for further details regarding the equipment status.

If any abnormal conditions are observed, refer to Maintenance chapter or contact the technical support team to obtain the suitable instructions to deal with the issue.

Reason RT431

GPS Precision-Time Clock

Chapter 5: Operation

This chapter introduces the Local and Remote Interface available for RT431.

1 Local HMI

The local HMI from RT431 is composed by three LED indicators (Power, Sync and Alarm) plus one reset button.



Figure 17: Local HMI from RT431

Power Indicator

The POWER indicator simply shows if the clock is energized or not.

Sync Indicator

The SYNC indicator shows that unit is synchronized with time reference from GPS satellites. This indicator blinks when the unit is searching for orbit data from GPS satellites, which is a common situation if the unit has been moved over long distances or has been out of operation for a long period of time. The SYNC indicator also lit up when the unit is receiving PTP messages from a Grandmaster Clock. This indicator will turn off as soon as the external reference is lost.

Alarm Indicator

The ALARM indicator should light up for a brief period of time while the unit is being initialized. After concluding the initialization, the unit will start operating and this indicator should turn off. In case the ALARM indicator remains on, the unit will not be operating and it will be necessary the operator attention.

Reset Button

If necessary to reset the RT431 to factory default settings, hold the reset button for 10 seconds. If IP address was forgotten, use the reset button to reset the IP address to factory default.

2 Web Interface (Remote Access)

To access RT43X web interface either a HTTP or HTTPS connection must be established through a web browser. For HTTPS connections, RT43X supports TLS 1.0, which have been deprecated by latest web browser releases. Thus, refer to web browsers versions supporting TLS 1.0:

- Google Chrome v90 or previous.
- Microsoft Edge v90 or previous.
- Mozilla Firefox v77 or previous.

The RT431 has a Web Interface for monitoring and configuring the unit. This section describes how to monitor the RT431 status in real time, check general system information and to log external timestamps pulses.

To connect to the Web Interface, enter the unit Ethernet port IP address into the address field of a web browser. For information on factory defaults for the Ethernet port, see the Installation chapter.

A start page containing the unit status information opens the Web Interface. The remaining monitoring and configuring sections are on a menu on the left. To access them, click the desired menu item.

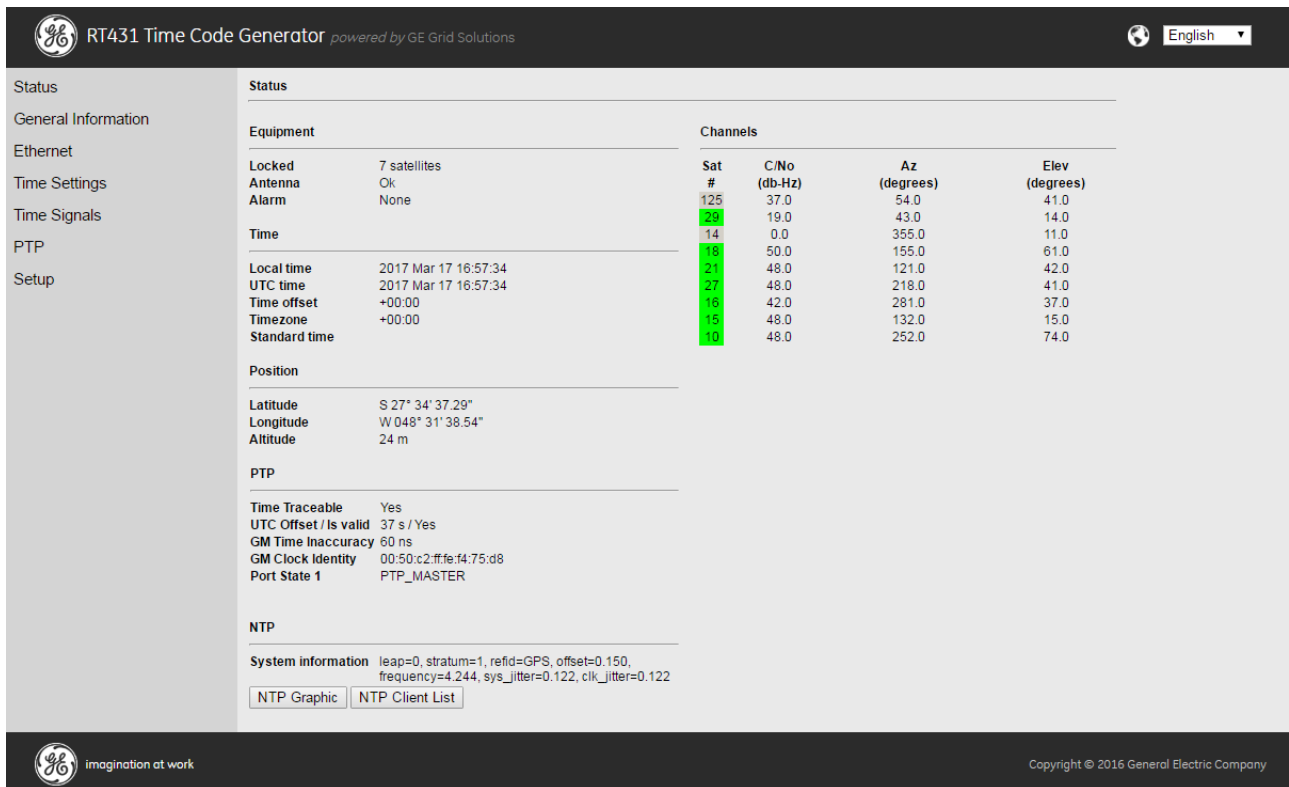

Figure 18: RT431 Web Interface

Web Interface Language

The Web Interface is available in five different languages: English, French, Spanish, Portuguese, Russian. To choose the language refer to the globe figure in the upper-right corner.

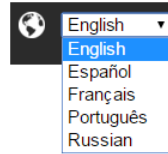

Figure 19: Languages available in the Web Interface

3 Monitoring Menus – Web Interface

The following sections will describe the monitoring menus from the Web Interface:

- Status: monitoring the status of the unit in real time.
- General Information: information of the unit system.

Status

The section Status of Web Interface, as shown below, allows monitoring status information of the unit in real time.

Status		Channels			
Equipment		Sat #	C/No (db-Hz)	Az (degrees)	Elev (degrees)
Locked	6 satellites	6	35.0	100.0	47.0
Antenna	Ok	12	36.0	220.0	39.0
Alarm	None	2	28.0	34.0	53.0
Time		24	41.0	240.0	71.0
Local time	2016 Nov 29 14:48:51	19	37.0	143.0	33.0
UTC time	2016 Nov 29 16:48:51	17	33.0	137.0	14.0
Time offset	-02:00				
Timezone	-03:00				
Daylight saving time					
Position					
Latitude	S 27° 34' 36.52"				
Longitude	W 048° 31' 38.22"				
Altitude	15 m				
PTP					
Time Traceable	Yes				
UTC Offset / Is valid	36 s / Yes				
GM Time Inaccuracy	60 ns				
GM Clock Identity	00:50:c2:ff:fe:69:bb:bb				
Port State 1	PTP_MASTER				
NTP					
System information					
leap=0, stratum=1, refid=GPS, offset=-0.000, frequency=11.944, sys_jitter=0.122, clk_jitter=0.122					
<input type="button" value="NTP Graphic"/> <input type="button" value="NTP Client List"/>					

Figure 20: Section to monitor the status of the unit in the Web Interface

The unit status information is grouped into areas, as follows:

- Equipment: shows operational information of the unit.
 - Locked: indicates if the unit is in the locked state or not. If yes, the number of monitored satellites is indicated.

- Antenna: indicates if the GNSS antenna is properly connected to the unit.
- Alarm: indicates if the unit is presenting internal failure.
- Time: presents the local time, UTC, off-set and time zone.
- Position: latitude, longitude and altitude information.
- PTP: shows status from PTP protocol, the time inaccuracy, GrandMaster Identity and the state from each port.
- NTP: presents the NTP information, including NTP stratum. The NTP graphic illustrates the NTP offset time and the NTP Client List displays all NTP clients that have recently sent requests to RT431. NTP Clients will appear up to 1 hour after from last NTP request sent. Both NTP Graphic and NTP Client List does not have automatic refresh.
- Channels: monitored satellites information (number, phase noise, azimuth and elevation). The background of Satellite number (Sat #) is green when receiving the health ephemeris data. A grey background means the satellite is not healthy by the moment, and it is not been used as reference.

General Information

The section General Information of the Web Interface displays system information of the unit.

General Information		
Firmware version	rt431-08A00.b5	
Hardware version	RT5s	
Serial number	160482	
Mac address Ethernet 1	00:50:C2:68:44:BB	
Product Key	BBAB8HGC*****BHBEJH88	
	Feature	Status
Ethernet 1	NTP	Enabled
	PTP	Enabled

Figure 21: Section to visualize general information of the system

The system information is as follows:

- Firmware Version: presents the current firmware version of unit.
- Hardware Version: presents the hardware version of unit.
- Serial Number: presents the serial number of unit.
- MAC Address Ethernet 1: presents the MAC address from Ethernet port.
- Key: partially displays the equipment key according to the cortec.
- Ethernet Ports: presents the status of NTP and PTP.

Reason RT431

GPS Precision-Time Clock

Chapter 6: Configuration

This chapter describes how to configure the RT431.

1 Web Interface

The Reason RT431 GPS Precision-Time Clock has a Web Interface for configuring network parameters, time parameters, time synchronization outputs and PTP standard, updating firmware, changing key, controlling access and manipulating configurations. To connect to the Web Interface, enter the unit Ethernet port IP address into the address field of a web browser. For information on factory default settings of the Ethernet ports, see Installation chapter.

A start page containing the unit status information opens once the Web Interface is accessed. The remaining monitoring and configuring sections are on a menu on the left. To access them, click the desired menu item. The configuring sections are:

- Ethernet: allows configuring the network parameters.
- Time Settings: allows configuring the time parameters.
- Time Signals: allows configuring signals sent from outputs.
- PTP: allows configuring PTP clock parameters in accordance with IEEE 1588.
- Setup: allows manipulating configurations, changing access control and key, and updating firmware.

User Name and Password

The configuration sections should be edited one by one and at the end of each section, it is necessary to transmit the changes made to the unit. Otherwise, the changes will not be saved. When transmitting changes to the unit, username and password will be required. Factory default username and password are:

Table 4: Factory default username and password

User name	configuration
Password	1234

Sending Configuration

To send the new configuration to the equipment, click on the <Apply> button. Then the username and password of the equipment will be requested.

Once both entered, click on login and the equipment will update its configuration. A message will be displayed informing the status of the update.

In case the new configuration is not transmitted to the unit, the changes will not be saved and will be discarded once the Web Interface is closed.

2 Ethernet

The Ethernet section of the Web Interface allows configuring network parameters of Ethernet port, gateway and DNS.

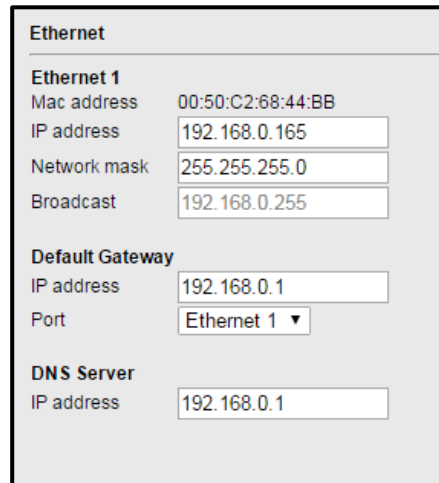

The screenshot shows the 'Ethernet' configuration page. It is divided into three sections: 'Ethernet 1', 'Default Gateway', and 'DNS Server'. Each section contains input fields for IP-related parameters. The 'Ethernet 1' section has fields for Mac address (00:50:C2:68:44:BB), IP address (192.168.0.165), Network mask (255.255.255.0), and Broadcast (192.168.0.255). The 'Default Gateway' section has fields for IP address (192.168.0.1) and Port (Ethernet 1). The 'DNS Server' section has a field for IP address (192.168.0.1).

Figure 22: Section to configure network parameters of the unit

Ethernet Ports

The Ethernet port allow communication via TCP/IP or UDP/IP networks.

- MAC Address: informs the MAC address of the network port.
- The IP Address field allows entering the IP address of the network port (only decimal numbers).
- The Network Mask field allows entering the network mask from the network to which the unit will be connected (only decimal numbers).
- The Broadcast field allows entering the subnet address to which the unit will be connected (only decimal numbers).

Default Gateway

The gateway configuration allows RT431 to communicate with other devices connected to a local subnet.

- The IP Address field allows entering the network port IP address of the unit (only decimal numbers).
- The field Port allows choosing the communication port to be used as gateway

DNS Server

The DNS server configuration allows the RT431 to communicate with the DNS server from a local subnet. The IP Address field allows entering the IP Address of the network's name server (only decimal numbers).

Ethernet - Configuration Summary

The table below presents all configurable network parameters and its possible values and variables.

Table 5: Summary of configurable network parameters

Ethernet Ports		
MAC Address	00:00:00:00:00:00	Not configurable
IP Address	0.0.0.0	Only decimal numbers
Network Mask	0.0.0.0	Only decimal numbers
Broadcast	0.0.0.0	Only decimal numbers
Gateway		
IP Address	0.0.0.0	Only decimal numbers
Port	Ethernet port 1	Not configurable
DNS Server		
IP Address	0.0.0.0	Only decimal numbers

3 Time Settings

The Time Settings section of the Web Interface allows configuring time parameters.

Time Settings

Timezone -03 h 00 m

DST

Start 00 h 00 m Third Sunday October

End 00 h 00 m Third Sunday February

NTP - Send local time

Figure 23: Section to configure time parameters

Time Parameters

- The field Timezone allows configuring the time zone of the unit, and converting UTC time to local time. Half hour time zones are supported.

- The field DST, when enabled, allows configuring the beginning and the end of Daylight Saving Time.
- When the option NTP – Send local time is selected, the local time in accordance with timezone and DST configuration is sent through NTP protocol. If this option is unselected, the UTC is sent.

Leap Second

The RT431 has built-in support for leap seconds, whenever indicated by the GPS (when operating as GPS Clock) or by PTP Grandmaster (when operating as PTP Slave). In both cases, the LCD display will show 23:59:60 at the moment the second increases (leap). In other words, while the last second of a normal day is 23:59:59, the last second of a day with Leap Second is 23:59:60.

This can also be verified in the Web Interface, under the NTP information of the Status section. The first field, "leap", indicates whether a leap second will be applied at the end of the day. Its standard value is 0 (normal, leap second warning). This field has the value 1 if the last minute of the day has 61 seconds; or the value 2 if the last minute of the day has 59 seconds. So from the beginning of the day that will take place the Leap Second field will have a value of 1 or 2; after the application of the Leap Second this field value is back to its normal value 0.

Besides the Web Interface, leap second treatment is also stored on the equipment's logging and may be checked after the occurrence of a leap. The processing and treatment of the Leap Second happens automatically and may not be disabled.

Network Time Protocol (NTP)

The NTP/SNTP is activated by default if the licensing was ordered (the General Information section displays if NTP is enabled or disabled). The NTP/SNTP operates at unicast (client/server) mode, in accordance with NTP v2 (RFC 1119), NTP v3 (RFC 1305) NTP v4 (RFC 5905) and SNTP (RFC 1769/2030/4330).

After initiating the clock, the NTP stratum is set to 16 and the Leap Second information is set as 3 (unknown). To inform the clients NTP when the time is global, the stratum level is set to 1 when the clock has its antenna connected and start tracking the satellites. By this time, the Leap Second take the value 0, 1 or 2 as described previously in the Leap Second section.

In the case of losing the antenna connection, the local clock (internal oscillator) is set as NTP reference, and after 11 minutes the NTP stratum level goes to 6 to inform the NTP clients the clock is in free running mode. Once the antenna connection is restored, the NTP stratum level returns to 1.

Time Settings - Configuration Summary

The table below presents all configurable time parameters and its possible values and variables.

Table 6: Summary of configurable time parameters

Timezone	h: from -12 to +14 (hours) m: 00 or 30 (minutes)
----------	---

DST	<p>selected: DST enabled</p> <p>unselected: DST disabled</p>
Start/End	<p>h: 00 up to 23 (hours)</p> <p>m: 00 up to 60 (minutes)</p> <p>first, second, third or last (week of the month)</p> <p>Sunday, Monday, Tuesday, Wednesday, Thursday, Friday or Saturday (day of the week)</p> <p>January, February, March, April, May, June, July, August, September, October, November or December (month)</p>
NTP – Send local time	<p>selected: the NTP/SNTP protocol will send the local time, in accordance with the timezone and DST configuration.</p> <p>unselected: NTP/SNTP will send the UTC time.</p>

4 Time Signals

The Time Signals section of the Web Interface allows configuring the signals applied to the outputs of the unit. See figure below:

Time Signals

Outputs

Output	Signal	Polarity
TTL1	IRIG-B ▼	Normal ▼
TTL2	IRIG-B ▼	Normal ▼
OC1	IRIG-B ▼	Normal ▼

TMARK h m s

DMARK h m s

PPX

Pulse width ms

Pulse width of 1us when unlocked

Disable PPS when unlocked

Cable delay compensation ns

Serial Datagram

Datagram

ACEB
 NMEA GPZDA
 MEINBERG
 Custom

On-time mark char

Serial

Speed bps
 Data bits
 Parity
 Stop bit

Figure 24: Section to configure time signals applied in the outputs

Outputs

- TTL 1 / 2: allows configuring the TTL-level electrical outputs 1 and 2. Both outputs have Euro Type connectors.
- OC 1: allows configuring the open collector output;

For each TTL electrical and open collector output, it is possible to configure the following signals:

- OFF - Output turned off;
- PPS - Output with 1 pulse-per-second;
- 100PPS - Output with 100 pulses-per-second;
- PPX - Output with programmable frequency pulses;
- PPM - Output with 1 pulse-per-minute;
- TMARK - Output with programmable time;
- DMARK - Output with programmable date and time;

- IRIG-B - Output with IRIG-B004 signal;
- DCF77 - Output with DCF77 signal.

It is also possible to choose normal or inverted polarity for each output individually.

- The field TMARK allows configuring time to generate a pulse with daily repetition. All outputs programmed to send TMARK pulses will be programmed within the same time.
- The field DMARK allow to set a date and time for a single pulse signal. All outputs using DMARK will be programmed to this same date and time.
- The field PPX allows configuring a pulse-frequency that can vary from 1 pulse-every-2-seconds to 1 pulse-per-day. All outputs programmed to send PPX pulses will be programmed within the same pulse-frequency.
- The field Pulse Width allows the user to adjust the duty cycle (pulse width of high state) for PPS, PPM, PPX, TMARK and DMARK.
- Pulse width of 1 μ s when unlocked: When selected, this option turns the PPS, PPM, PPX, TMARK and DMARK pulses into a 1 μ s pulse when not locked to satellites, indicating that the synchronization signal is local, not global.
- Disable PPS when unlock time after (s): When selected, this option disables the PPS signal after the specified time, in seconds.
- The field Cable delay compensation allows entering a value between 0 and 999 nanoseconds (ns) to compensate propagation delay according to the cable length. Refer to Appendix D for more details of how to compensate the cable delay.

Serial datagram

- The field Datagram allows configuring a datagram sent by the serial port (TDx pin).
- ACEB, NEMEA, GPZDA, Meinberg and customizable datagrams are possible. When choosing a customizable datagram, it is necessary to enter characters with information required. For more details about ACEB, NEMEA, GPZDA and Meinberg datagrams, see Appendix C;
- A serial datagram is sent each second. The field On-time mark allows choosing if the sending will be synchronized with the beginning or the end of the datagram;
 - Start of first: pulse synchronized with the beginning of the datagram;
 - Start of last: pulse synchronized with the end of the datagram;
- Serial: allows configuring the serial port parameters.
 - The field Speed allows choosing data transmission speed of the serial port, which can be 38400, 19200, 9600, 4800 or 1200 bps;
 - The field Data allows defining the data bits, which can be 7 or 8;
 - The field Parity allows choosing the serial port parity, which can be odd, even, or none;
 - The field Stop bit allows choosing the datagram stop bit, which can be 1 or 2.

Customizable datagrams

The RT431 allows defining a datagram "ASCII" to be sent once per second by the serial port, using the characters described below. The datagram characters can be single or special. The maximum number of character in a customizable datagram is 16. The single characters allowed are: 0..9 A..Z a..z \$ \{ \} () [] . , ; : ! ? @ < > \$ \# * _ - \% \ \$ blank and empty.

- %H %M %S %d %m %y %x correspond to 2 characters; (Date and Time sent through datagrams refers to the local time zone configured in the RT431)
- %j : correspond to 3 characters (length(str) + 1 for each event);
- %Y correspond to 4 characters (length(str) + 2 for each event)
- %u %w %s %o %O %Q %1 %2 %3 %4 %5 %% : correspond to 1 character (length(str) - 1 for each event)

The following special characters can be used to enter information into the datagram:

Table 7: Customizable datagram special characters

Paramet.	Values	Num. of Char.	Description
%H	00 ... 23	2	Hours
%M	00 ... 59	2	Minutes
%S	00 ... 59	2	Seconds
%j	001 ... 366	3	Day of the year
%d	01 ... 31	2	Day of the month
%m	01 ... 12	2	Month
%y	00 ... 99	2	Year (the last two digits)
%Y	2000 ... 2099	4	Year (four digits)
%u	1 ... 7	1	Day of the week (1 = Monday)
%w	0 ... 6	1	Day of the week (0 = Sunday)
%s	'S' or '_'	1	DST ('S' if DST '_' in odder case)
%o	'_' or '#'	1	Status ('_' if locked, '#' in odder case)
%O	'_' or '*'	1	Status ('_' if locked, '*' in odder case)
%Q	'_' or '?'	1	Status ('_' if locked, '?' in odder case)

%1	<SOH>	1	Start-of-header (ASCII 01)
%2	<STX>	1	Start-of-text (ASCII 02)
%3	<ETX>	1	End-of-text (ASCII 03)
%4	<LF>	1	Line feed (ASCII 10)
%5	<CR>	1	Carriage returns (ASCII 13)
%x		2	Checksum type 1
%%	'%'	1	Character '%' (ASCII 37)

'_' is the character 'blank (ASCII 32).

Checksum type 1 consists of two hexadecimal digits, which represent the result of a XOR from all characters comprised between '\\$' and '*' ('\\$' e '*' not included). It is useful for NMEA datagrams.

One example of serial datagram is presented below:

"Day:%d;Month:%m;Year:%Y;Hour:%H;Minute:%M;Second:%S;,%3"

Time Signals - Configuration Summary

The table below presents all configurable parameters for the time synchronization outputs.

Table 8: Summary of all configurable parameters for outputs

Outputs	
Output TTL 1 / 2	Signal: OFF, PPS, 100PPS, PPX, PPM, TMARK, DMARK, IRIG-B or DCF77 Polarity: normal or inverted
Output OC 1	Signal: OFF, PPS, 100PPS, PPX, PPM, TMARK, DMARK, IRIG-B or DCF77 Polarity: normal or inverted
TMARK	Hour: 00 up to 23 Minutes: 00 up to 59 Seconds: 00 up to 59

DMARK	Year: from 2012 to 2030 Month: January to December Day: 01 to 31 Hour: 00 up to 23 Minutes: 00 up to 59 Seconds: 00 up to 59
PPX	1 pulse-every-2-seconds to 1 pulse-per-day
Pulse width	PPS, PPM, PPX, TMARK and DMARK pulses width from 10 to 990 milliseconds
Pulse width of 1us when unlocked	selected: PPS, PPM, PPX, TMARK and DMARK pulses width of 1us when unit is unlocked unselected: pulse width does not change when unit is unlocked
Disable PPS when unlock time after (s)	selected: disable PPS signal when the unit is unlocked after defined period in seconds unselected: maintain PPS signal when unit is unlocked
Cable delay compensation	0 up to 999 nanoseconds
<i>Serial datagram</i>	
Datagram	ACEB, NEMEA, GPZDA, Meinberg or Custom
On-time-mark	Char: start of first (start of first) Char: start of last (start of last)
Serial	Speed: 38400, 19200, 9600, 4800, 2400 or 1200 bps Data: 7 or 8 Parity: none, even or odd Stop bit: 1 or 2

5 PTP Configuration

The PTP section from Web Interface allows the user to configure the parameters for the PTP protocol.

To enable the PTP in RT431, mark the “PTP Enabled” box. If the field “Force operation as slave” is unmarked, the RT431 operates as Grandmaster Clock, otherwise the unit acts

as Ordinary Clock (slave). Note when equipment is operating as Ordinary, the antenna signal is ignored.

To disable PTP, make sure both boxes, “PTP Enabled” and “Force operation as slave”, are disabled.

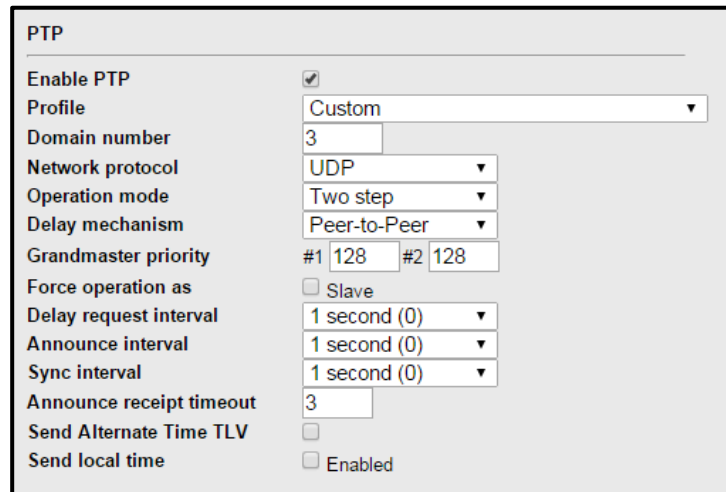

PTP	
Enable PTP	<input checked="" type="checkbox"/>
Profile	Custom
Domain number	3
Network protocol	UDP
Operation mode	Two step
Delay mechanism	Peer-to-Peer
Grandmaster priority	#1 128 #2 128
Force operation as	<input type="checkbox"/> Slave
Delay request interval	1 second (0)
Announce interval	1 second (0)
Sync interval	1 second (0)
Announce receipt timeout	3
Send Alternate Time TLV	<input type="checkbox"/>
Send local time	<input type="checkbox"/> Enabled

Figure 25: Section to configure PTP parameters

Comparison between PTP Power Profiles

Following the latest standards, RT431 offers the most recent IEEE 1588v2 extended profiles for power system protection, control automation, and data communication applications, such as: IEEE C37.238:2017, IEC/IEEE 61850-9-3:2016 and IEEE C37.238:2011. All these are pre-configured on the RT431, making it easier to configure an IEEE 1588v2 network.

The IEEE C37.238:2017 and IEC/IEEE 61850-9-3 are completely compatible and can work together without restrictions on the same network by setting its domain number. Although the C37.238:2011 was superseded by the other two standards, it is still available for legacy networks and may be compatible depending on the IEEE 1588v2 network configuration.

The following table presents a comparison between the main characteristics of each profile.

Table 9: Comparison between PTP Power Profiles

	IEEE C37.238:2011 PTP Power Profile	IEEE C37.238:2017 PTP Power Profile	IEC 61850-9-3 PTP Profile for Power Utility Automation
Network Protocol	Ethernet Layer 2	Ethernet Layer 2	Ethernet Layer 2
Delay Mechanism	Peer-to-Peer (P2P)	Peer-to-Peer (P2P)	Peer-to-Peer (P2P)
Operation Mode	One Step	One or Two Step(s)	One or Two Step(s)
Sync / Announce Message Interval	1 per second / 1 per second	1 per second / 1 per second	1 per second / 1 per second
Grandmaster Priority	#1 and #2 = 128 Equal for all Grandmaster	Selectable, allowing to choose the best grandmaster for holdover conditions	Selectable, allowing to choose the best grandmaster for holdover conditions

Profile

When configuring PTP, the first point to be decided is which PTP profile, or which common parameters, will be used along all PTP devices. The RT431 has five options to be selected as profile:

- Power Profile – IEEE C37.238/2017: profile with predetermined characteristics, where the user cannot change any major parameter from PTP, such as Network Protocol, Operation mode and Delay mechanism. The characteristics are shown in next figure. The configurable parameters for Power Profile 2017 are:
 - Domain number;
 - VLAN ID and Priority;
 - Operation mode as One Step or Two Step;
 - Operation as Master or Slave;
 - Send Alternate Time TLV;
 - If the PTP should send the local time (considering the timezone and DST parameters configured) or UTC time.

Figure 26: Characteristics from PTP Power Profile IEEE C37.238:2017

- Power Utility – IEC/IEEE 61850-9-3/2016: profile with predetermined characteristics, where the user cannot change any major parameter from PTP, such as Network Protocol and Delay mechanism. The characteristics are shown in next figure. The configurable parameters for Power Utility Profile are:
 - Domain number;
 - VLAN ID and Priority;
 - Operation mode as One Step or Two Step;
 - Operation as Master or Slave;
 - If non-Power messages (PTP messages that are not in compliance with IEEE C37.238) should be ignored;
 - Send Alternate Time TLV;
 - If the PTP should send the local time (considering the timezone and DST parameters configured) or UTC time.

Figure 27: Characteristics from PTP for Power Utility Automation, in accordance with IEC/IEEE 61850-9-3:2016

- Power Profile – IEEE C37.238/2011: profile with predetermined characteristics, where the user cannot change any major parameter from PTP, such as Network Protocol, Operation mode and Delay mechanism. The characteristics are shown in next figure. The configurable parameters for Power Profile are:
 - Domain number;
 - VLAN ID and Priority;
 - Operation as Master or Slave;
 - If non-Power messages (PTP messages that are not in compliance with IEEE C37.238) should be ignored;
 - Grandmaster ID (identification);
 - Network time inaccuracy, if delays are known from the network architecture used;
 - If the PTP should send the local time (considering the timezone and DST parameters configured) or UTC time.

The screenshot shows the PTP configuration window with the following settings:

Parameter	Value
Enable PTP	<input checked="" type="checkbox"/>
Profile	Power - IEEE C37.238/2011
Domain number	0
Network protocol	Ethernet level 2
VLAN	<input checked="" type="checkbox"/> id 0x0005 priority 0
Operation mode	One step
Delay mechanism	Peer-to-Peer
Grandmaster priority	#1 128 #2 128
Force operation as	<input type="checkbox"/> Slave
Delay request interval	1 second (0)
Announce interval	1 second (0)
Sync interval	1 second (0)
Announce receipt timeout	3
Ignore non-Power Announces	<input checked="" type="checkbox"/>
Send Alternate Time TLV	<input checked="" type="checkbox"/>
Grandmaster id	5
Network time inaccuracy	0 ns
Send local time	<input type="checkbox"/> Enabled

Figure 28: Characteristics from PTP Power Profile IEEE C37.238:2011

- P2P Default: profile partly configurable, with some predetermined parameters, which cannot be modified. The non-editable characteristics are shown in its respective fields. The non-editable characteristics are.
 - Domain number 0.
 - Priority 128 in both Ethernet ports.
 - Operation as master only.
- Custom Profile: profile with all features freely configurable by a user.

Domain number

The RT431 allows configuring the domain number to be identified by the PTP clock, so it only answers messages from this domain. The domain number field allows selecting a domain number between 0 and 255 which the unit will recognize.

Network protocol

This field defines the network layers where the PTP protocol will be applied. It is possible to use PTP protocol in a network layer with IEEE 802.3 Ethernet (layer 2) or UDP/IPv4 (layer 3) connection. If Ethernet (layer 2) is selected, VLAN may be used.

Operation mode

The field operation mode allows configuring the operation mode according to the form RT431 sends its messages, as follows:

- One-step: Sync information and timestamp information are sent in the same data packet;
- Two-step: Sync information is sent in one data packet, and timestamp information is sent in another data packet.

Delay mechanism

The RT431 is capable of measuring the delay between master and slave clocks using End-to-end and Peer-to-peer, according to IEEE1588 standard. The field Delay mechanism allows configuring the type of measurement of the delay, as follow:

- End-to-end: measurement of delay across the network between master clock and slave clock;
- Peer-to-peer: measurement of delay only between master and slave clocks as neighbors.

Grandmaster Priority

When configured as master, BMC algorithm tie breaking criteria priorities must be attributed. The fields Grandmaster priority #1 and #2 allow configuring the priorities of both Ethernet ports, in which #1 is the first and #2 is the last tie breaking criterion. Between the first and the last tie breaking criterion, other clock characteristics are analyzed. The priority values can vary from 0 to 255. The lower the attributed value is, the higher its priority is.

PTP Messages

In PTP protocol, messages containing Sync information and timestamps are sent across the network in multicast mode.

Announce messages are used to inform devices connected to the network about the existence of a master clock available to send Sync packets. The clock connected to the network operating as a master should send Sync messages. In case it is a two-step clock, Follow Up messages containing the timestamp will be send after the Sync messages.

In RT431, it is possible to choose the frequency to send messages and the waiting time of Announce message receipt, through the fields below:

- Delay request interval allows choosing the frequency to send messages with delay measurement. It is possible to configure the unit to send 16 messages per second until one message every-32-seconds.

- Announce interval allows choosing the frequency to send messages that apply the device to become a network master candidate. It is possible to configure the unit to send 16 messages per second until one message every-32-seconds.
- Sync interval allows choosing the frequency to send Sync messages. It is possible to configure the unit to send 16 messages per second until one message every-32-seconds.
- Announce receipt timeout allows choosing the waiting time of Announce message receipt when RT431 is being used as slave. In case an Announce message is not received within this time interval, the unit assumes that the current master clock is unavailable and executes the BMC to select another master clock. It is possible to configure values between 2 and 255 seconds.

PTP - Configuration Summary

The table below presents all configurable PTP parameters and its possible values and variables.

Table 10: Summary of configurable PTP parameters

Profile	
Power IEEE C37.238	Predetermined parameters
Power Utility IEC 61850-9-3	Predetermined parameters
P2P Default	Domain number 0, priority 128, and operation as master
Custom	All parameters are configurable
Parameters	
Domain number	From 0 to 255
Network protocol	UDP or Ethernet level 2
Operation mode	one-step or two-step
Delay	P2P or E2E
Grandmaster Priority	# 1 from 0 to 255 # 2 from 0 to 255
For operation as	Slave: enables the use as slave
Intervals between sent messages	
Delay request	From 1/16 to 32 seconds

Announce	From 1/16 to 32 seconds
Sync	From 1/16 to 32 seconds
Response time of messages	
Announce receipt	From 2 to 255 seconds
TLV Messages	
Send Alternate Time TLV	Selected: TLV messages will be sent Unselected: TLV messages will not be sent
UTC or Local Time	
Send local time	Selected: local time is sent through PTP protocol. Unselected: UTC is sent through PTP protocol.

6 Setup

The Setup section of the Web Interface allows updating the firmware, manipulating configurations, changing key and configuring password. Firmware and key change (equipment upgrade) instructions are described in Maintenance chapter.

Firmware Update

File No file chosen

Configuration Management

Backup configuration
Click the button below to download the configuration file.

Restore configuration
File No file chosen

Restore to factory default configuration
Click the button below to overwrite all configuration to factory default settings. Save a **Backup configuration** before proceed with this option. The system will be automatically rebooted after the restore.

Equipment Key

Key

Password configuration

New password
Confirm password

GPS configuration

Enable GPS almanac reset on equipment power up.
 Enable GPS Stationary mode.

Demo Mode

Enable demo mode - force equipment to LOCKED, using internal clock as reference.

System log file

Click the button below to download the system log.

Reboot System

Click the button below to reboot the system.

Generate HTTPS Certificate

Click the button below to generate HTTPS certificate.

Figure 29: Setup section in Web Interface

Configuration Management

- Backup Configuration: It is possible to receive a file with the current configuration of the unit and store it in a directory on the computer. Saving the final configuration of the unit as a backup is recommended.
 - Download: allows saving the current configuration of the unit in “.rt431”. By clicking <Download> a window will open to save the file in a directory on the computer.
- Restore Configuration: It is possible to send a configuration file in “.rt431” format to the respectively unit.
 - File: allows entering the directory and file name of the configuration that will be sent to the unit.
 - Search: allows searching the configuration file in Windows' directories.
 - Restore: allows transmitting the selected configuration file to the unit. By clicking <Restore> a window will open requiring configuration username and password. Enter the username and password and click <Login>. To cancel the action, click <Cancel>. During the transmission, the unit will go momentarily out of operation.
- Restore to factory default configuration: Restore the equipment to factory default settings.

Password configuration

- New password: allows entering a new password for configuration.
- Confirm password: confirmation of the new password entered.

Reset Satellites Almanac

This option deletes the satellites Almanac data stored in the clock. Afterwards the equipment will take several minutes to rebuild the Almanac.

The almanac consists of orbit courses and status information for each satellite in the constellation, an ionosphere model, and information to relate satellites derived time to Coordinated Universal Time (UTC).

Stationary Mode

This option enable the Stationary Mode, which keeps the equipment in locked state even with one satellite. Note the equipment must track at least four satellites before entering in stationary mode. Besides, if this option is enabled, the equipment must be in a fixed position.

To enable the Stationary Mode, select the option “Enabled Stationary Mode” and click on the <Apply> button.

Demo mode

Mostly used in demonstrations, this option forces the clock into a LOCKED state independently if the antenna is or is not connected, as the internal oscillator is used as time reference. In demo mode, the Locked Led will remain alight and it is possible to configure the date and time manually, in Time Settings tab from equipment Web Interface.

All time protocols work in Demo Mode: PTP, NTP, SNTP, IRIG-B and all other low frequency signals.

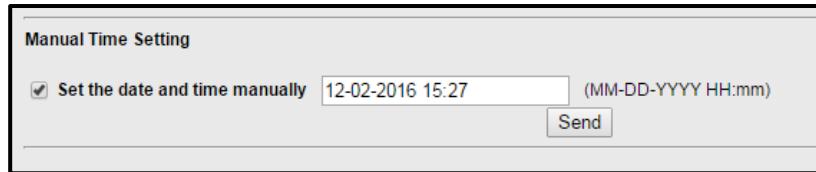

Figure 30: Manual Time setting – only available in Demo Mode

Note: in demo mode the Ethernet ports are not in sync with each other, although they follow the manual date and time settings. This means that PTP slaves connected to different Ethernet ports will have different time stamp and consequently might not be synced. The physical interfaces (BNC, optical, open collector...) are always in sync with the Ethernet port 1.

Log Files

Technical support may request log files in case maintenance is required.

Reboot System

This feature reboots the system without the need to withdraw the power supply.

Generate HTTPS Certificate

A default HTTPS certificate is generated upon first boot. The created certificate is valid for 10 years and it is self-signed (each device will have its own individual key). The user may renew the certificate by clicking in the button “Generate HTTP Certificate”, and the new created certificate will also be valid for 10 years.

In case the HTTPS certificate expires, the user may use a HTTP connection to access the web interface and generate a new HTTPS certificate. Alternatively, if the allowed by the HTML browser, the user may create an exception to login through HTTPS mode (even considering the expired certificate) and generate a new HTTPS certificate.

Note a new certificate will only be created if the user clicks on this button. Equipment rebooting or firmware upgrade will not renew the HTTPS certificate.

Reason RT431

GPS Precision-Time Clock

Chapter 7: Maintenance

This chapter describes the information to consider for an eventual maintenance. For any further assistance required please contact the information and call center as follows:

GE Grid Solutions:
Worldwide Contact Center
Web: www.GEGridSolutions.com/contact
Phone: +44 (0) 1785 250 070

1 Time Synchronization Failure (Locked Signaling)

The clock availability is higher than 99.999%, but time synchronization failure may occur. If availability rate is lower than that, the follow actions are recommended:

- Check for configuration being transmitted to the unit. During transmission, the unit should momentarily go out of operation to reboot. This behavior is normal and no action is required. The Locked indicator will lit as soon as the unit resumes operation.
- Make sure the GPS antenna is properly connected to the unit.
- Make sure the antenna cable being used is in accordance with the specifications presented in Technical Specification.
- Make sure the unit is synchronized with at least 4 satellites by checking the Web Interface. Otherwise, check the location of the antenna, making sure that it is installed according to the recommendations of Installation chapter.

If the unit is operating without time reference in the GPS antenna, the failure may be signaled in different ways: Local interface, Web Interface and data packets from IRIG-B, NTP, PTP and SNMP protocols.

Sync indicator (HMI)

The Locked indicator will be off when there is no time reference in the GPS antenna input. As soon as a GPS antenna is connected, the indicator will start blinking while it downloads a satellite almanac. This behavior is normal and no actions are necessary. The Sync indicator will stop blinking and stay lit as soon as the download is completed (it may take a few minutes when a unit is moved over long distances or has been out of operation for a long period).

Remote monitoring (Web Interface)

In the monitoring area of the Web Interface it is shown the information Locked and the number of satellites when there is time reference in the GNSS antenna input, and Unlocked when reference is disconnected.

IRIG-B Signal

When the Time Quality bits from IRIG-B signal are all in 0, the unit is in Locked state, i.e., there is time reference in the GPS antenna input. In case the reference is disconnected or the signal is weak, the bits combination will differ from zero.

PTP Protocol

In PTP protocol, there is a bit called time traceable that, when set, informs the existence of time reference in the GPS antenna input. Besides the existence of a reference signal, it is possible to qualify the signal, according to the bits clock class and clock accuracy, in which the criterion for assessing the quality of the signal is configured in the device that receives the PTP messages.

NTP Protocol

In NTP protocol, information is given in layers, known as Stratum, numbered from 0 to 16. Layer 1 indicates the unit is operating with time reference from the GNSS antenna input, when the antenna is connected. Stratum layer 6 indicates the reference was interrupted, i.e., the unit lost the antenna connection. A stratum level 16 means an antenna was never connected to the unit after initialization.

SNTP Protocol

In SNTP protocol, a data set is sent containing time synchronization and the status of the external time reference.

When the status data is zero, it represents the lack of time reference in the GPS antenna input. When it is 1, it represents the existence of reference in the GPS antenna input, i.e., it is in LOCKED state.

2 Firmware Update

Eventually, new firmware versions will be released with updates and improvements to the unit.

The Setup section of the Web Interface allows updating the firmware, manipulating configurations, changing key, and changing configuration username and password.

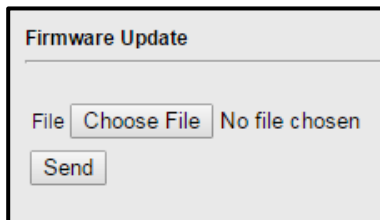

Figure 31: Section to update firmware

To update the unit firmware, access the Setup section of the Web Interface by typing the unit IP address in a default browser and follow the steps below:

1. Click <SEARCH> and it will allow the search of a new firmware update file in the directories. Enter the directory and the firmware update file name in the <FILE> field and it will be sent to the unit. The update file has the extension “.fw431”.
2. Click <SEND> to send the new firmware to the unit.
3. After clicking <SEND>, a new window will open requesting username and configuration password. Enter username and password and click <LOGIN>. To cancel the action, click on <CANCEL>.
4. During the transmission, the unit will momentarily go out of operation.
5. After the change is completed, check the main page of the Web Interface.

Note: After updating, it is recommended to clear the browsing data (CTRL+ F5) when accessing the web interface for the first time.

3 Equipment Upgrade - Key Change

It is possible to update the unit key in order to enable new features, according to the commercial policy. Contact sales to acquire a new key to enable the desired features.

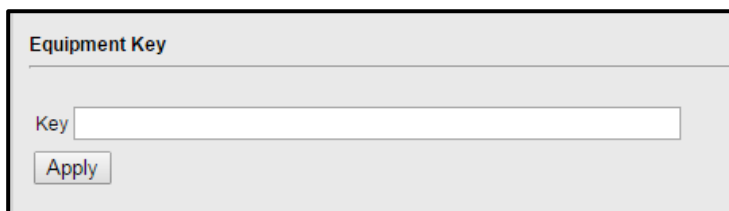

Figure 32: Section to equipment upgrade – key change

To change the unit key, access the Setup section from Web Interface, typing the unit IP address in a default browser and follow the steps below:

1. Enter the new key (36 alphanumeric characters) in the Key field.
2. Click <Apply> to send the new key to the unit.
3. After clicking <Apply>, a new window will open requesting username and configuration password. Enter username and password and click <Login>. To cancel the action, click <Cancel>.

Note: If the key mismatches the MAC Addresses from the equipment, a warning message will pop up saying “The new Key’s MAC does not match with the current Key”. In this case, it is recommended to cancel the upgrade and contact the local support. If the user decides to continue, the new key will change the equipment MAC addresses.

4. During the transmission, the unit will momentarily go out of operation. A message communicating the key change will show up on the screen.
5. After the change is completed, check the main page of the Web Interface.

4 Cleaning Instructions

Before cleaning the equipment, make sure that the primary voltage is removed. If it is necessary cleaning the exterior of the equipment, use only a dry cloth. Internally it is not required any cleaning.

5 Equipment Return

All parts and components comprising Reason devices must be repaired exclusively by GE Grid Solutions. In case of equipment malfunction the customer must get in contact with GE's Contact Centre and never attempt to repair the device by his own.

To request equipment repair service, call GE Grid Solutions to check out shipment options and receive the technical assistance order code.

The equipment must be packed in its original package or a suitable package to protect against impacts and moisture.

Send equipment to address supplied including the sender's identification and the technical assistance reference.

Reason RT431

GPS Precision-Time Clock

Chapter 8: Technical Specification

This chapter describes the technical specifications of the product.

1 Power Supply

Table 11: Power supply specifications

Operating nominal voltage	100-250Vdc, 110-240Vac
Operating voltage range	80-300Vdc, 88-264Vac
Frequency	50/60 Hz \pm 3 Hz
Power Consumption	MAX 20 VA
	Typical 10 W

2 GPS Antenna

GPS Antenna Receiver

Table 12: GPS Antenna input specifications for temporal synchronization

GPS Receiver	GPS L1 Frequency, C/A code
Sensibility	-152 dBm (After acquisition)
	-142 dBm (During acquisition)
Antenna type	Active
Antenna's supply	3.3 V, max 100 mA
Connector	BNC (female)
Time Receiver Autonomous Integrity Monitoring (TRAIM) supported	

GNSS Antenna Type

Table 13: GNSS Antenna specifications

Type	3.3 V Active GNSS antenna (<20 mA)
Frequency	1588 ± 3MHz
Output / VSWR	2.0 Max
Impedance	50 Ω
Gain	30dB @ 25°C
Noise	3.3dB max (25°C ± 5°C)
Azimuth coverage	360° (omni-directional)
Elevation coverage	0°-90° elevation (hemispherical)
Operating Temperature	-40°C to +90°C
Connector	TNC Female

Antenna Cable

Table 14: Antenna Cable specifications

Length	Delay (ns)	Description	Attenuation @1500MHz
15 m (50 ft)	62,0	TNC Male to BNC Male connectors, RG58 Type	< 0.5 dB/m
25 m (82 ft)	102,6	TNC Male to BNC Male connectors, RG58 Type	< 0.5 dB/m
40 m (131 ft)	163,6	TNC Male to BNC Male connectors, RG58 Type	< 0.5 dB/m
75 m (246 ft)	305,9	TNC Male to BNC Male connectors, RG8 Type	< 0.2 dB/m

100 m (328 ft)	407,5	TNC Male to BNC Male connectors, RG8 Type	< 0.2 dB/m
150 m (492 ft)	611,3	TNC Male to BNC Male connectors, RG8 Type	< 0.2 dB/m
Velocity of propagation		82%	
Impedance		50 ohms	
Capacitance		81pF/m	

Surge Arrester

Table 15: Surge arrester specifications

Nominal discharge current I_n (8/20μs)	10 kA
Dynamic residual voltage	< 600 V
Band width	< 4 GHz
Insertion Loss	\leq 0.1dB
Impedance	50 Ω
Connector	BNC
Includes 1 meter long cable	

3 Internal Oscillator

Table 16: Internal oscillator specifications

Drift (without external reference)	< 0.1 ppm (10^{-7})
---	-------------------------

The RT431 drift is lower than 0.1 ppm. One million seconds corresponds to 11 days, 13 hours, 46 minutes and 40 seconds. So our clock has a drift lower than 100 ms every million seconds.

This accuracy in ppm can also be expressed as a percentage:

$$\pm 0.1 / 1,000,000 = \pm 0.00001\%$$

4 Outputs

Connectors

See figures below to refer to the connectors of RT431.

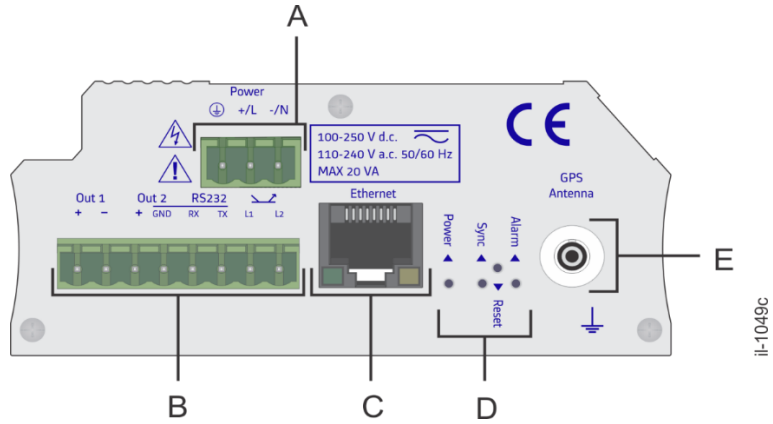

Figure 33: Connectors of RT431

Table 17: RT431 connectors

Indicator	Description
A	Power supply, high voltage AC/DC
B	2 TTL electrical outputs 1 open collector output 1 RS232 serial output
C	RJ45 communication port via Ethernet network
D	Indicators of Power, Synchronization, Alarm and one reset button
E	GPS antenna input

TTL Electrical Outputs

Table 18: Electrical outputs specifications

Time Accuracy	100 ns (peak)
Number of Outputs	2

TTL Voltage Level	5 Vdc
High Level	> 4.8 Vdc
Low Level	< 0.2 Vdc
Impedance	18 Ω
Maximum current	150 mA
Connectors	2-pin Euro Type
Both TTL outputs are non-isolated	

¹ Level above which the equipment recognizes as activated output.

² Level below which the equipment recognizes as disabled output.

Open Collector Electrical Output

Table 19: Open collector outputs specifications

Number of Outputs	1
Maximum collector emitter DC voltage	400 Vdc
Maximum current	300 mA
Connectors	2-pin Euro Type

Serial Port (RS232)

Table 20: RS232 serial port specifications

Number of Outputs	1
Signal Level	RS232
Bitrate	1200, 2400, 4800, 9600, 19200 or 38400 bps
Data bits	7 or 8
Stop bits	1 or 2

Parity	none, even or odd
Connector	3-pin Euro Type

5 Precision Time Protocol PTP (IEEE 1588)

Table 21: PTP time synchronization protocol specifications

Time Accuracy	< 100 ns
Protocols	UDP/IPv4 (Layer 3) IEEE 802.3 (Layer 2)
Delay Compensation	End-to-End (E2E) Peer-to-Peer (P2P)
Profiles	<ul style="list-style-type: none"> • Power - IEEE C37.238/2011 • Power - IEEE C37.238/2017 • Power Utility - IEC/IEEE 61850-9-3/2016 • P2P Default • Custom

6 Ethernet Port

Table 22: Ethernet port specification

Number of port	1
Transmission Rates	10/100 Mbps
Connector	RJ45
Protocols Supported	NTP v2 (RFC 1119) NTP v3 (RFC 1305) NTP v4 (RFC 5905) SNTP (RFC 1769/2030/4330)

	SNMP (v1, v2c and v3), including MIB support. IEEE 1588 PTP HTTP, TCP/IP, UDP
--	---

7 Environment

Table 23: Environment specification

Operating temperature range	-40°C ... +55°C (or -40°F to +131°F)
As tested per IEC 60068-2-1	-40°C
As tested per IEC 60068-2-2	+85°C
Maximum operating altitude	2000 m (6560 ft)
Relative humidity	5 ... 95%, non-condensing

Table 24: Enclosure Protection IEC 60529

IP rating	IP20
-----------	------

8 Type Test

Table 25: EMC tests were performed according to IEC 60255-26 referring to the following standards

IEC 61000-4-2:2008	6 kV contact / 8 kV air
IEC 61000-4-3:2006	10 V/m
IEC 61000-4-4:2012	2 kV @ 5 kHz
IEC 61000-4-5:2005	Differential mode: 1 kV Common mode: 2 kV
IEC 61000-4-6:2008	10 V
IEC 61000-4-8:2009	30 A/m continuous 300 A/m @ 1 s
IEC 61000-4-11:2004 IEC 61000-4-29:2000	<ul style="list-style-type: none"> A.C. and D.C. voltage dips Test level: 0% residual voltage Duration time

	<p>A.C.: 1 cycle</p> <p>D.C.: 16.6 ms</p> <ul style="list-style-type: none"> • Test level: 40% residual voltage <p>Duration time</p> <p>A.C.: 12 cycles</p> <p>D.C.: 200ms</p> <ul style="list-style-type: none"> • Test level: 70% residual voltage <p>Duration time</p> <p>A.C.: 30 cycles</p> <p>D.C.:500 ms</p> <ul style="list-style-type: none"> • A.C. and D.C. voltage interruptions <p>Test level: 0% residual voltage</p> <p>Duration time</p> <p>A.C.: 300 cycles</p> <p>D.C.: 5 s</p>
IEC 61000-4-17:1999	<p>Test level: 15% of rated DC value</p> <p>Test frequency: 120 Hz, sinusoidal waveform.</p>
IEC 61000-4-18:2006	<p>Voltage oscillation frequency: 1 MHz</p> <p>Differential mode: 1 kV peak voltage;</p> <p>Common mode: 2.5 kV peak voltage</p>
IEC 60255-26:2008	<p>Shut-down ramp: 60 s</p> <p>Power off: 5 m</p> <p>Start-up ramp: 60 s</p>
CISPR11:2009	<p>Radiated emission</p> <p>30 to 230 MHz – 50 dB (µV/m) quasi peak at 3 m and 230 to 1000 MHz – 57 dB (µV/m) quasi peak at 3 m</p>
CISPR22:2008	<p>Radiated emission</p> <p>The definition of the limit frequency is based on the maximum internal frequency of the equipment. On RT431, the maximum internal</p>

	<p>frequency is 100 MHz. For this case, the levels of CISPR 11 satisfy the normative IEC 60255-26.</p> <p>Conducted emission</p> <p>0.15 to 0.50 MHz - 79dB (µV) quasi peak; 66 dB (µV) average</p> <p>0.5 to 30 MHz - 73dB (µV) quasi peak; 60 dB (µV) average</p>
--	---

Table 26: Safety tests

<p>IEC 61010-1</p> <p>CE Certification</p>	<p>Safety Requirements</p>
<p>IEC 60255-5</p>	<p>Impulse: 5 kV</p> <p>Dielectric withstand: 3.3 kVdc</p> <p>Insulation: > 100 MΩ</p>

Table 27: Environmental tests

IEC 60068-2-1	-40°C, 16 hours (Cold)
IEC 60068-2-2	+85°C, 16 hours (Dry heat)
IEC 60068-2-30	95% no condensation, +55°C (Damp heat)
IEC 60068-2-14	-40°C to +85°C / 9 hours / 2 cycles (Change of temperature)
IEC 60255-21-1	Class 2 (Vibration)
IEC 60255-21-2	Class 1 (Shock)
IEC 60255-21-3	Class 2 (Seismic)

9 Dimensions, Weight

Table 28: Dimensions and weight specification RT431

Height	117 mm (4.6 in)
Width (body)	105 mm (4.1 in)
Depth	51 mm (2 in)
Weight	1 kg (2.2 lbs)

RT431 dimensions are shown below.

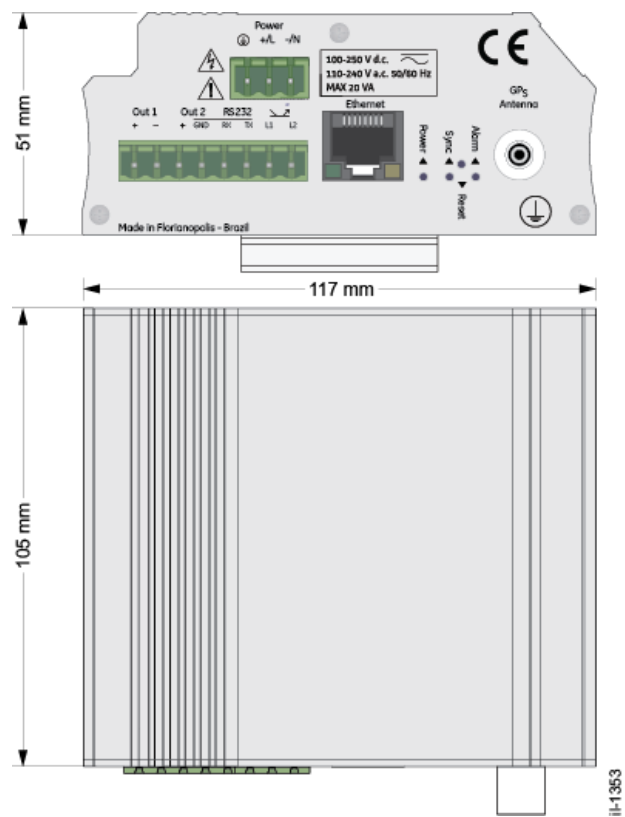

Figure 34: RT431 Dimensions

Reason RT431

GPS Precision-Time Clock

Chapter 9: Ordering Options

This chapter describes the CORTEC number formation from RT431.

1 RT431 Cortec

Variants	Order Number						Optional		
	1-5	6	7	8	9-10	11	12	13	14
Model Type RT431 GPS Precision-Time Clock	RT431								
Power Supply 24-48 Vdc 100-250 Vdc / 110-240 Vac		4 3							
Ethernet Interface RJ45 copper 100BASE-TX for configuration only RJ45 copper 100BASE-TX for NTP server and configuration RJ45 copper 100BASE-TX for PTP (IEEE 1588) server, NTP server and configuration RJ45 copper 100BASE-TX for PTP (IEEE 1588) client			C N P S						
Customization / Regionalisation GE branding				C					
Firmware Version Latest available firmware - 08 Firmware version number - 07 (withdraw)					08 07				
Hardware Design Suffix Hardware release version						B			
GPS Antenna Without antenna 3.3V TNC Female active GNSS antenna							0 2		
Antenna Cable No cable 15 m (50 ft) TNC Male to BNC Male (Attenuation < 0.5 dB/m @ 1500 MHZ) 25 m (82 ft) TNC Male to BNC Male (Attenuation < 0.5 dB/m @ 1500 MHZ) 40 m (131 ft) TNC Male to BNC Male (Attenuation < 0.5 dB/m @ 1500 MHZ) 75 m (246 ft) TNC Male to BNC Male (Attenuation < 0.2 dB/m @ 1500 MHZ) 100 m (328 ft) TNC Male to BNC Male (Attenuation < 0.2 dB/m @ 1500 MHZ) 150 m (492 ft) TNC Male to BNC Male (Attenuation < 0.2 dB/m @ 1500 MHZ)							0 1 2 3 4 5 6		
Surge Arrester Without surge arrester 10 kA, 50 Ohms, BNC-type connector Surge Arrester for 0-2000 MHZ							0 1		

Issue L

Reason RT431

GPS Precision-Time Clock

Chapter 10: Appendixes

Appendix A – IRIG-B Standard Summary

Table 29: IRIG-B standard summary

0	P_r	reference bit (P_r)	
1	$P_r + 10$ ms	seconds 1	seconds (0 ... 59 or 60)
2	$P_r + 20$ ms	seconds 2	
3	$P_r + 30$ ms	seconds 4	
4	$P_r + 40$ ms	seconds 8	
5	$P_r + 50$ ms	index bit (0)	
6	$P_r + 60$ ms	seconds 10	
7	$P_r + 70$ ms	seconds 20	
8	$P_r + 80$ ms	seconds 40	
9	$P_r + 90$ ms	position identifier 1 (P_1)	
10	$P_r + 100$ ms	minutes 1	minutes (0 ... 59)
11	$P_r + 110$ ms	minutes 2	
12	$P_r + 120$ ms	minutes 4	
13	$P_r + 130$ ms	minutes 8	
14	$P_r + 140$ ms	index bit (0)	

15	$P_T + 150 \text{ ms}$	minutes 10	
16	$P_T + 160 \text{ ms}$	minutes 20	
17	$P_T + 170 \text{ ms}$	minutes 40	
18	$P_T + 180 \text{ ms}$	index bit (0)	
19	$P_T + 190 \text{ ms}$	position identifier 2 (P_2)	
20	$P_T + 200 \text{ ms}$	hours 1	hours (0 ... 23)
21	$P_T + 210 \text{ ms}$	hours 2	
22	$P_T + 220 \text{ ms}$	hours 4	
23	$P_T + 230 \text{ ms}$	hours 8	
24	$P_T + 240 \text{ ms}$	index bit (0)	
25	$P_T + 250 \text{ ms}$	hours 10	
26	$P_T + 260 \text{ ms}$	hours 20	
27	$P_T + 270 \text{ ms}$	index bit (0)	
28	$P_T + 280 \text{ ms}$	index bit (0)	
29	$P_T + 290 \text{ ms}$	position identifier 3 (P_3)	
30	$P_T + 300 \text{ ms}$	days 1	day of the year (1 ... 365 or 366)
31	$P_T + 310 \text{ ms}$	days 2	
32	$P_T + 320 \text{ ms}$	days 4	
33	$P_T + 330 \text{ ms}$	days 8	
34	$P_T + 340 \text{ ms}$	index bit (0)	
35	$P_T + 350 \text{ ms}$	days 10	
36	$P_T + 360 \text{ ms}$	days 20	

37	$P_T + 370$ ms	days 40	
38	$P_T + 380$ ms	days 80	
39	$P_T + 390$ ms	position identifier 4 (P_4)	
40	$P_T + 400$ ms	days 100	
41	$P_T + 410$ ms	days 200	
42	$P_T + 420$ ms	index bit (0)	
43	$P_T + 430$ ms	index bit (0)	
44	$P_T + 440$ ms	index bit (0)	
45	$P_T + 450$ ms	index bit (0)	
46	$P_T + 460$ ms	index bit (0)	
47	$P_T + 470$ ms	index bit (0)	
48	$P_T + 480$ ms	index bit (0)	
49	$P_T + 490$ ms	position identifier 5 (P_5)	
50	$P_T + 500$ ms	year 1	The last 2 digits of the year (00 ... 99)
51	$P_T + 510$ ms	year 2	
52	$P_T + 520$ ms	year 4	
53	$P_T + 530$ ms	year 8	
54	$P_T + 540$ ms	index bit (0)	
55	$P_T + 550$ ms	year 10	
56	$P_T + 560$ ms	year 20	
57	$P_T + 570$ ms	year 40	
58	$P_T + 580$ ms	year 80	

59	$P_T + 590 \text{ ms}$	position identifier 6 (P_6)	
60	$P_T + 600 \text{ ms}$	index bit (0)	
61	$P_T + 610 \text{ ms}$	index bit (0)	
62	$P_T + 620 \text{ ms}$	Daylight Saving Pending (DSP)	1 during the minute before beginning or end of DST
63	$P_T + 630 \text{ ms}$	Daylight Saving Time (DST)	1 during DST
64	$P_T + 640 \text{ ms}$	Time Offset Sign (0=+, 1=-)	difference between local time and UTC (negative for West Greenwich)
65	$P_T + 650 \text{ ms}$	Time Offset 1	difference between local time and UTC (-12 ... +12)
66	$P_T + 660 \text{ ms}$	Time Offset 2	
67	$P_T + 670 \text{ ms}$	Time Offset 4	
68	$P_T + 680 \text{ ms}$	Time Offset 8	
69	$P_T + 690 \text{ ms}$	position identifier 7 (P_7)	
70	$P_T + 700 \text{ ms}$	Time Offset – 0.5h	0 – none 1 – Additional 0.5h time offset
71	$P_T + 710 \text{ ms}$	Time Quality (bit 1)	4-bit code representing approx. clock time error: 0000: Clock is locked 0001, 0010, ..., 1010, 1011: Time within 10^{-9} s, 10^{-8} s, ..., 1s, 10s of UTC 1111: Fault — time not reliable
72	$P_T + 720 \text{ ms}$	Time Quality (bit 2)	
73	$P_T + 730 \text{ ms}$	Time Quality (bit 3)	
74	$P_T + 740 \text{ ms}$	Time Quality (bit 4)	
75	$P_T + 750 \text{ ms}$	Parity (odd)	Module 2 of the sum of the data bits 0 to 74 (Bits 75-99 not included in the sum)
76	$P_T + 760 \text{ ms}$	Continuous Time Quality (bit 1)	3-bit code representing the estimated maximum time error in the transmitted message.
77	$P_T + 770 \text{ ms}$	Continuous Time Quality (bit 2)	
78	$P_T + 780 \text{ ms}$	Continuous Time Quality (bit 3)	

79	$P_T + 790$ ms	position identifier 8 (P_8)	
80	$P_T + 800$ ms	time-of-day 1	seconds of the year (0 ... 86399)
81	$P_T + 810$ ms	time-of-day 2	
82	$P_T + 820$ ms	time-of-day 4	
83	$P_T + 830$ ms	time-of-day 8	
84	$P_T + 840$ ms	time-of-day 16	
85	$P_T + 850$ ms	time-of-day 32	
86	$P_T + 860$ ms	time-of-day 64	
87	$P_T + 870$ ms	time-of-day 128	
88	$P_T + 880$ ms	time-of-day 256	
89	$P_T + 890$ ms	position identifier 9 (P_9)	
90	$P_T + 900$ ms	time-of-day 512	
91	$P_T + 910$ ms	time-of-day 1024	
92	$P_T + 920$ ms	time-of-day 2048	
93	$P_T + 930$ ms	time-of-day 4096	
94	$P_T + 940$ ms	time-of-day 8192	
95	$P_T + 950$ ms	time-of-day 16384	
96	$P_T + 960$ ms	time-of-day 32768	
97	$P_T + 970$ ms	time-of-day 65536	
98	$P_T + 980$ ms	index bit (0)	
99	$P_T + 990$ ms	position identifier 0 (P_0)	

Appendix B – PTP Standard Concepts (IEEE1588)

Description

The Precision Time Protocol (PTP) is an ultimate time synchronization accuracy protocol for Ethernet networks. On a local area network, it achieves clock accuracy in the sub-micro second range, making it suitable for applications where synchronization is essential to the measurement system. The ultimate time accuracy of the protocol is obtained from the compensation of propagation delay information between the source and destination.

IEEE 1588 - 2002 standard, officially entitled "Standard for a Precision Clock Synchronization Protocol for Networked and Control Systems", originally defined PTP protocol. In 2008, the standard was revised and had its protocol accuracy and robustness improved.

The protocol describes a hierarchical master-slave architecture designed for clock distribution, where the root timing reference is called Grandmaster clock, which transmits synchronization information to the clocks residing on its network segment.

Definitions according to IEEE 1588 Standard

- **Clock:** IEEE1588 standard defines a clock as a network device capable of using PTP protocol and providing a measurement of the passage of time since a defined epoch.
- **Synchronized Clocks:** According to IEEE1588 standard, two clocks are synchronized to a specified uncertainty if they have the same epoch and their measurements of time of a single event at an arbitrary time differ by no more than that uncertainty.
- **Master Clock:** According to IEEE1588, it is a clock that is the source of time to which all other clocks on that path synchronize.
- **Grandmaster Clock:** IEEE1588 defines a grandmaster clock, within a domain, as a clock that is the ultimate source of time for clock synchronization using the protocol.
- **Slave Clock:** IEEE1588 defines a slave clock as a clock that is coordinated with a master clock, i.e., it is capable of recognizing time Sync messages from a master clock.
- **Best Master Clock Algorithm:** According to IEEE1588, The Best Master Clock algorithm (BMC) performs a distributed selection of the best candidate clock to be used as clock source based on the following clock properties:
 - A universally unique numeric identifier for the clock. This is typically constructed based on a device's MAC address.
 - Time information quality is based on the time system adopted as reference.
 - Priority assigned to a clock in its configuration.
 - Clock variance, which represents its stability based on observation of its performance over time.

The algorithm establishes an order of searching for the attributes and from the results, determines which will be used as time source.

- **Boundary Clock:** According to IEEE1588 standard, a boundary clock has multiple PTP ports in a domain and maintains the timescale used in the domain. It may

serve as the source of time, i.e., be a master clock, and may synchronize to another clock, i.e., be a slave clock.

- **Ordinary Clock:** According to IEEE1588 standard, an ordinary clock has a single PTP port in a domain and maintains the timescale used in the domain. It may serve as a source of time, i.e., be a master clock, or may synchronize to another clock, i.e., be a slave clock.
- **Transparent Clock:** According to IEEE1588, a transparent clock is a device that measures the time take from a PTP event message to transit the device and provides this information to clocks receiving this PTP event message.
- **End-to-end Transparent Clock:** According to IEEE1588 standard, it is a transparent clock that supports the use of the end-to-end delay measurement mechanism between slave clocks and master clock.
- **Peer-to-peer Transparent Clock:** According to IEEE1588 standard, it is a transparent clock that, in addition to providing PTP event transit time information, also provides corrections for the propagation delay of the link connected to the port receiving the PTP event message.
- **One-step Clock:** According to IEEE1588 standard, it is a clock that provides time information using a single event message.
- **Two-step Clock:** According to IEEE1588 standard, it is a clock that provides time information using the combination of an event message and subsequent general message.
- **Accuracy:** According to IEEE1588 standard, the mean of the time or frequency error between the clock under test and a perfect reference clock, over an ensemble of measurements. Stability is a measure of how the mean varies with respect to variables such as time, temperature, and so on. The precision is a measure of the deviation of the error from the mean.
- **Profile:** According to IEEE1588 standard, profile is a set of all allowed PTP features applicable to a device.
- **Timeout:** According to IEEE1588 standard, timeout is the time in which a device waits to receive synchronization messages. In case the message is not received within this time interval, the clock that sends messages is considered out of operation and the BMC algorithm is ran, and chooses a second master clock.

Hierarchical Topology

IEEE1588 defines a hierarchical topology composed of different types of clocks that send and receive synchronization messages.

In hierarchical topology, a boundary clock is elected the grandmaster clock that sends PTP messages for the entire network, which are also connected ordinary and boundary clocks. The boundary clocks connected to the network are used as intermediate time source for ordinary clock. The selection of the source clock is performed by each receiver device, using the BMC algorithm.

Multicast and Unicast Networks

The first revision of the IEEE1588 standard specifies only multicast network where a PTP message sent by a network port can be received by all other ports connected to the same network. The great advantage of the multicast network is that the master clock

sends only one packet of time Sync to the network, and it is received by all slave devices connected to that network.

The second revision of the standard also specifies the form of unicast communication where the clock master has to send time synchronization packets for each slave device connected to the network, which requires the master clock to have greater processing power and causes the network traffic to be more overloaded.

PTP Synchronization

Through use of the BMC algorithm, PTP elects a master source of time for an IEEE1588 domain and for each network segment in the domain. Clocks determine the offset between themselves and their master. Let the variable represent physical time. For a given slave device, the offset $o(t)$ at a time t is defined by:

$$o(t) = s(t) - m(t)$$

where $s(t)$ represents the time measured at the clock at physical time t , and $m(t)$ represents the time measured at the master at physical time t .

The master clock periodically broadcasts the current time as a message to the other clocks. Under IEEE1588-2088, broadcasts are up to 10 messages per second.

Each broadcast begins at time $T1$ which is a Sync multicast message sent by the master to all the clocks in the domain. A clock receiving this message takes note of the local time $T1'$ when this message is received. The master may subsequently send a multicast Follow Up with accurate timestamp. Not all masters have ability to present an accurate timestamp in the Sync message. It is only after the transmission is complete that they are able to retrieve an accurate timestamp for the Sync transmission from their network hardware. Masters with this limitations use the Follow Up message to convey $T1$. Masters with PTP capabilities built into their network hardware are able to present an accurate timestamp in the Sync message and do not need to send Follow Up messages. In order to accurately synchronize to their master, clocks must individually determine the network transit time of the Sync messages. The transit time is determined indirectly by measuring round-trip time from each clock to its master. The clocks initiate an exchange with their master designed to measure the transit time d . The exchange begins with a clock sending a Delay Req message at time $T2$ to the master. The master receives and time stamps the Delay Req at time $T2'$ and responds with a Delay Resp message. The master includes the time stamp $T2'$ in the Delay Resp message. Through these exchanges, a clock learns $T1$, $T1'$, $T2$ and $T2'$.

If d is the transit time for the Sync message, and \tilde{o} is the constant offset between master and slave clocks, then:

$$T1 - T1' = \tilde{o} + d$$

$$T2 - T2' = -\tilde{o} + d$$

Combining the above two equations, we find that:

$$\tilde{o} = \frac{(T1' - T1 - T2' + T2)}{2}$$

The clock now knows the offset \tilde{o} during this transaction and can correct itself by this amount to bring it into agreement with their other master.

Network protocols

IEEE1588 standard defines the network layers where the PTP protocol will be applied. It is possible to use PTP protocol in a network layer with IEEE 802.3 Ethernet (layer 2) or UDP/IPv4 (layer 3) connection.

The layer 3 (UDP/IPv4) is used in more environments facilitating the compatibility of sending and receiving messages between the devices connected to the network. Once the PTP protocol has low traffic when compared to other protocols, the network traffic is not limiting factor of the use of layer 3.

To use the layer 2 it is necessary that the network has ETHERNET connections between all master and slave clocks, which are not common when the network is divided into subnets and there is not an interconnection between them. The advantage of using layer 2 is that the traffic through the network is smaller because the sent packets do not require including IP and UDP address.

Clock operation mode

PTP protocol requires the master clock sending Sync messages periodically to all slave clocks connected to the network. Furthermore, master clocks must register and communicate to the slave clocks the exact timestamp in which the data packets were sent. This information can be sent in a single packet or two packets separately.

In One-step operation mode, the Sync information is sent in the same data packet as the timestamp of the message. In Two-step operation mode, the Sync information is sent in a data packet and the timestamp information of the message is sent in another one. The accuracy of both modes is the same.

Delay measurement mechanism

According to IEEE1588 a slave clock is capable of measuring the delay of message propagation that represents the time that a message takes to cross the master-slave path. The measurement of this delay is necessary to perform a time correction of the time of receipt of the message in relation to the time it was sent. The delay measurement is performed by sending messages containing the timestamp of the time of receipt to the master clock which sends a reply with information of the delay.

The second review of IEEE1588 standard, in 2008, specifies two ways of compensating delay: End-to-end and Peer-to-peer:

- End-to-end: measurement of delay across the network between master and slave clocks.
- Peer-to-peer: measurement of delay only between master and slave clocks as neighbors.

The advantage of P2P is that the time accuracy is immune to change in the network topology, since the delay between each master-slave connection is calculated for each packet sent. However, the P2P solution is possible only when all devices in the network are transparent, i.e., they can perform delay measurement between one point and another. In network applications where the network comprises devices without measurement of delay, it is necessary to use the E2E mode, which calculates the delay in a general way between the two ends of the network.

Master, Slave and Grandmaster clocks

In PTP protocol, master clocks send message packets with Sync information, slave clocks receive and process the Sync messages and grandmaster clocks are the source of synchronization for the entire network.

IEEE1588 standard specifies the Best Master Clock algorithm (BMC) which selects the best candidate to be elected the master of the network, used as time source. The selection is performed from the attributes and attributed priorities to the possible candidates. The algorithm establishes a search order, and from the results, it determines which one will be the clock used as time source.

PTP Messages

In PTP protocol, Sync messages followed by the timestamp messages are sent to the entire network in multicast mode, in which a PTP message sent by a network port can be received by all other ports connected to the same network. The advantage of multicast mode network is that the master clock sends only one packet containing time information to the network and this packet is received by all slave devices connected to this network.

Among the messages specified by IEEE1588 standard, the ones that stand out are related to synchronization, timestamp and propagation delay.

The Announce messages are used to inform the devices connected to the network about the existence of a master clock available to send Sync messages. The Announce message includes a packet of values that indicates the time accuracy of the clock, enabling the BMC algorithm to decide which of the available clocks will be used as master. The speed the Announce messages are sent influences directly the frequency the slave will perform the BMC algorithm. Many announce messages can be transmitted at the same time through the network and the slave clock is responsible to process these messages. All devices connected to the network that are able to operate as master should periodically send Announce messages to the network, becoming candidates to be master of the network.

The clock connected to the network selected as master by the BMC algorithm, should send Sync messages, and in case it is a two-step clock, it should also send a Follow Up message, containing a timestamp. The sending interval of the messages is configurable and its standard value, specified by IEEE1588 standard, is one-message-per-second. This interval specifies the frequency the slave devices receive synchronization information, allowing to adjust its internal clocks to use the master clock as time reference. In the interval between two Sync messages the slave devices operate free from external time reference and the time stability in this period is determined by its internal time base, that can be, for example a crystal oscillator. By choosing the frequency to send Sync messages through the master clock, it is important to consider the accuracy of the internal clocks of the slave devices that will be synchronized by it, and also the bandwidth, because the higher the frequency to send messages is, the higher the network traffic is.

The delay measurement of messages passing through devices is important to reach the accuracy required by IEEE1588 standard. Especially in E2E networks, the propagation delay measurement is crucial for the synchronization. In networks with E2E delay

measurement, the frequency the slave devices should measure delay, which results in sending and receiving messages, should be according to the network stability regarding the variation of this information.

Appendix C – Serial Datagrams

RT431 can be configured to send datagrams through serial port. The datagrams defined for the unit are ACEB, NEMEA GPZDA, and Meinberg.

ACEB Datagrams

ACEB datagram comprises 13 bytes, sent once per minute in the second second of the minute (i.e. 12:00:02, then 12:01:02). The datagram information is described below.

Table 30: ACEB Datagram Information

Byte	Description	Possible values
1	Delimiter	0xFF
2	Header	0x01
3	Status	0x00 (locked) or 0x01 (not locked)
4	Start of transmission	0x02
5	Day of week	BCD 01 (Monday) ... BCD 07 (Sunday)
6	Year	BCD 00 ... 99
7	Month	BCD 01 ... 12
8	Day of month	BCD 01 ... 31
9	Hour	BCD 00 ... 23
10	Minute	BCD 00 ... 59
11	Second	BCD 02
12	End of transmission	0x03
13	Synch byte	0x16

NEMEA GPZDA Datagram

NEMEA ACEB datagram comprises 32 characters, sent once per second. The datagram information is described below:

`$GPZDA,hhmmss.0,DD,MM,YYYY,*CC<CR><LF>`

Table 31: GPZDA Datagram Time Information

Parameters	Possible values	Description
hh	00 ... 23	hours
mm	00 ... 59	minutes
ss	00 ... 59	seconds
ddd	001 ... 366	Julian day
DD	01 ... 31	day of the month
MM	01 ... 12	month
YYYY	2000 ... 2099	year (4 digits)

Table 32: GPZDA Datagram Line Feed and Carriage Return Information

Characters	ASCII (decimal)	ASCII (hexadecimal)	Description
<LF>	10	0A	line feed
<CR>	13	0D	carriage return

Table 33: GPZDA Datagram Checksum Information

Parameters	Description	Comments
CC	checksum	two hexadecimal digits representing the result of exclusive OR of all characters between '\$' and '*' ('\$' and '*' are excluded)

Meinberg Datagram

Meinberg datagram comprises 32 characters, sent once per second. The datagram information is described below:

<STX>D:DD.MM.YY;T:w;U:hh.mm.ss;uv__<ETX>

Table 34: Meinberg Datagram Time Information

Parameters	Possible values	Description
hh	00 ... 23	hours
mm	00 ... 59	minutes
ss	00 ... 59	seconds
DD	01 ... 31	day of the month
MM	01 ... 12	month
YY	00 ... 99	year (2 digits)
w	1 ... 7	day of the week (1 = Monday)

Table 35: Meinberg Datagram Beginning and End Information

Characters	ASCII	ASCII	Description
<STX>	02	02	start-of-datagram
<ETX>	03	03	end-of-datagram
_	32	20	space

Table 36: Meinberg Datagram Locked State Information

Parameters	Description	Comments
u	status	'_' se "locked", '#' if not
v	status	'_' se "locked", '*' if not

Appendix D – Antenna Delay Compensation

The antenna cable affects the unit's performance in two different ways: signal attenuation and signal propagation delay.

Signal Attenuation

Signal attenuation is related to cable type and overall cable length. When using the active antenna supplied by GE Grid Solutions, total attenuation should not exceed 32 dB.

Total attenuation can be computed by using:

$$A = A_u \times l$$

Where A_u is the attenuation per unit length for the given cable and l is the overall cable length.

The table below shows a few typical cable configurations and the associated total attenuation.

Table 37: Antenna cables attenuation @ 1500 MHz (± 1 dB)

Cable length	Cable RG58	Cable RG8
15 m (50 ft)	7 dB	—
25 m (82 ft)	12 dB	—
40 m (131 ft)	19 dB	—
75 m (246 ft)	—	13 dB
100 m (328 ft)	—	18 dB
125 m (410 ft)	—	22 dB
150 m (492 ft)	—	26 dB

Propagation Delay

The antenna cable delays the signal received from the satellites. In applications in which the ultimate time accuracy is desired, this delay should be compensated inside the unit. Typically, the delay introduced by coaxial cables is in the magnitude of 4 ns/m (1.2 ns/ft) of cable length.

The exact delay can be computed by using:

$$T = \frac{1}{CK_v} \times l$$

Where $C = 3 \times 10^8$ m/s is the speed of light, $K_v = 0.8 \dots 0.85$ is a constant which depends on the cable and l is the cable length in meters.

The table below summarizes some typical delays caused by coaxial cables.

Table 38: Attenuation of antenna cables

Cable length	Typical delay
15 m (50 ft)	60 ns
20 m (82 ft)	100 ns
50 m (164 ft)	200 ns
75 m (246 ft)	300 ns
100 m (328 ft)	400 ns
125 m (410 ft)	500 ns
150 m (492 ft)	600 ns

Appendix E – Application Examples

Application Example 1: Traditional and Modern Time Sync

The first example illustrates the traditional and modern manners to synchronize devices, using a single time source: RT430. In the left, the clock provides NTP and IRIG-B for legacy IEDs, and in the right, the PTP represents the modern protocol for time synchronization. Using Ethernet networks, the PTP is distributed through PTP-aware Ethernet switches and whenever a legacy IED needs to be included in a modern architecture, the RT431 acts as a PTP translator converting PTP to IRIG-B or PPS.

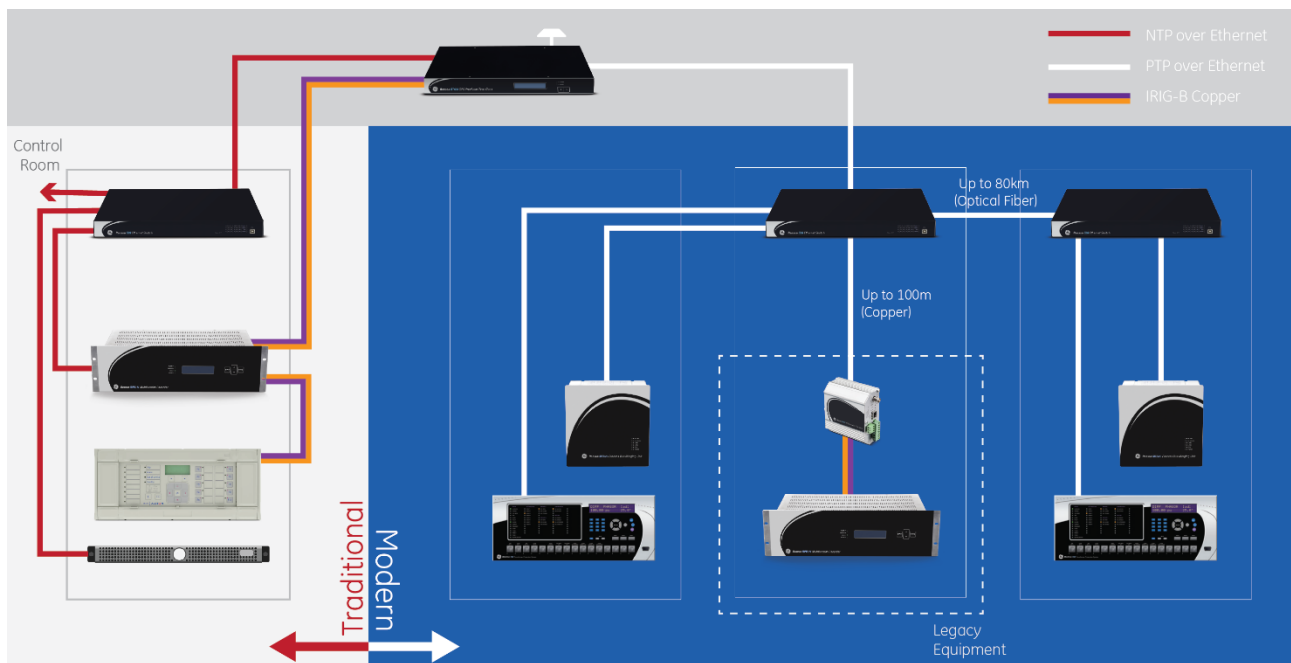

Figure 35: Traditional x Modern Time Synchronization

Application Example 2: System Wide Grandmaster Clock

Using the RT430 along with GE JunglePAX is a great way to have PTP over a wide network. The next figure exemplifies an architecture which a given application has a local PTP Grandmaster clock, which commonly will be the Best Grandmaster Clock for the local IEDs. Whenever this local clock became unavailable or does not represent the best accurate clock, the local IEDs can count with a remote PTP Grandmaster clock, which is called as System Wide Grandmaster.

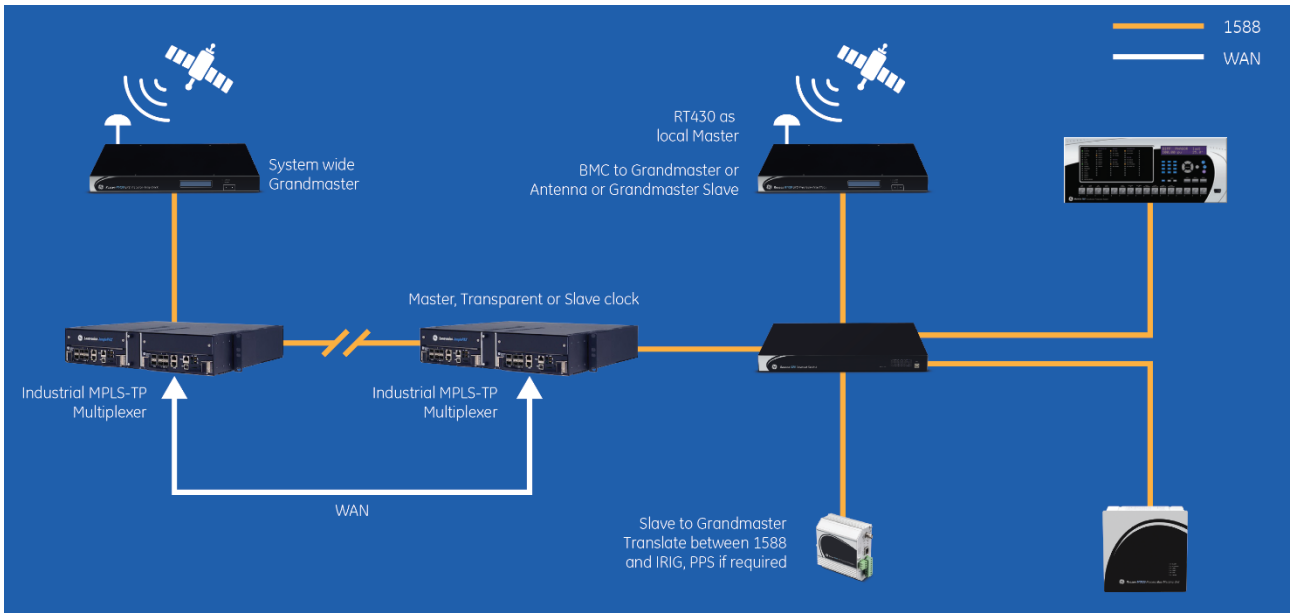

Figure 36: System Wide Grandmaster Clock

Application Example 3: Synchrophasor, TWFL and Process Bus Applications

Requiring 1 μ s time accuracy, this third example demonstrate the best way to synchronize devices used for Synchrophasor (PMU), Travelling Waves Fault Locators (TWFL) and Process Bus devices.

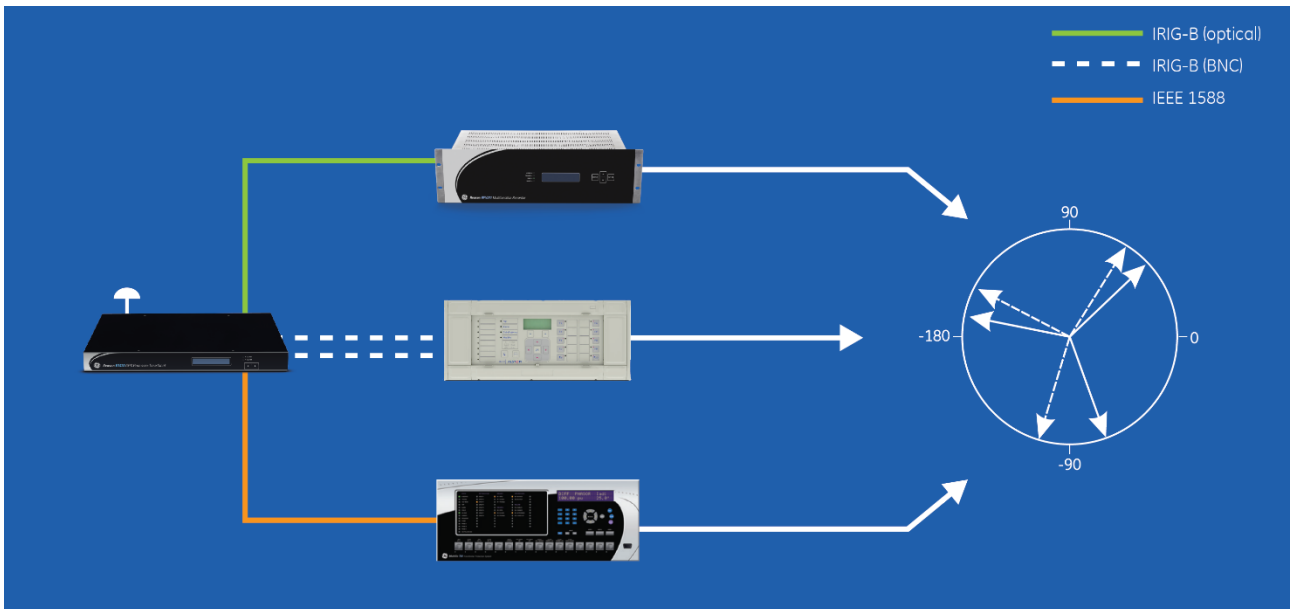

Figure 37: Synchrophasor devices synced by RT430/434



Figure 38: TWFL application using RT430/434 for Time Sync

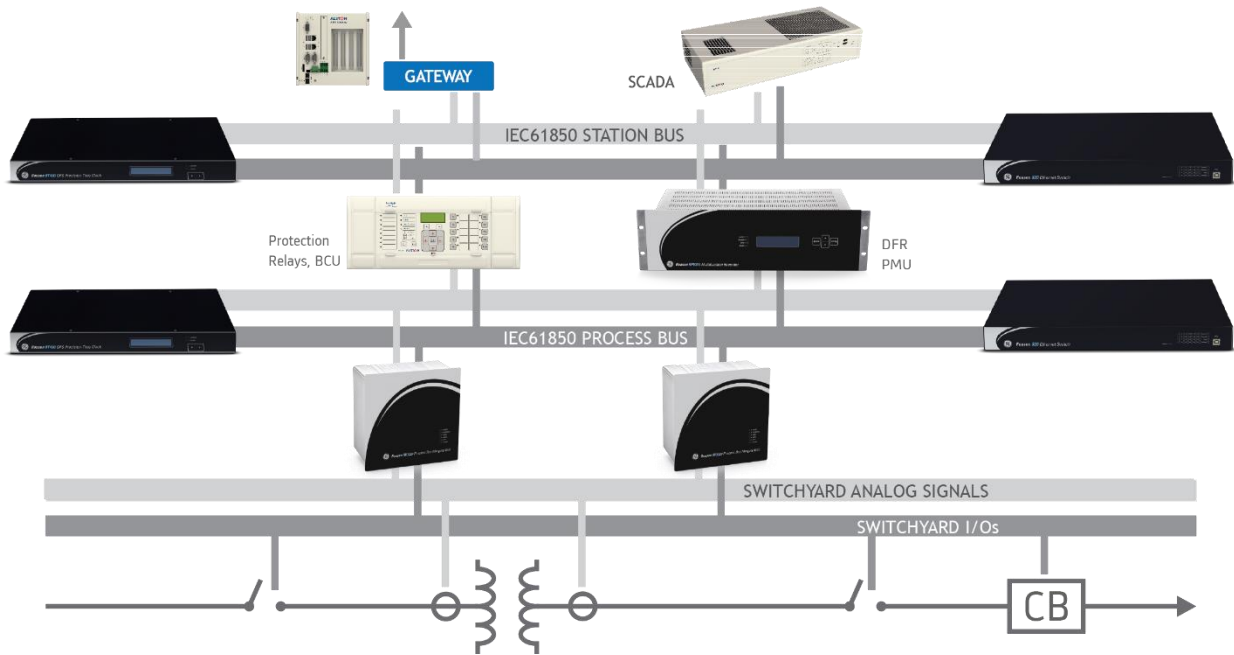

Figure 39: Process Bus application using PTP via the Station Bus network.

Application Example 4: IEEE 1588 in a PRP Network

RT430 offers the highly accurate IEEE 1588v2 Precision Time Protocol (PTP) combined with the Parallel Redundancy Protocol IEC 62439-3:2016, ensuring 100 ns accuracy and high availability in time synchronization over Ethernet networks. In case of failure in one of the redundant networks, the recovery-time for the PTP is zero. In other words, the PRP architecture overcomes any single network failure without affecting the data transmission.

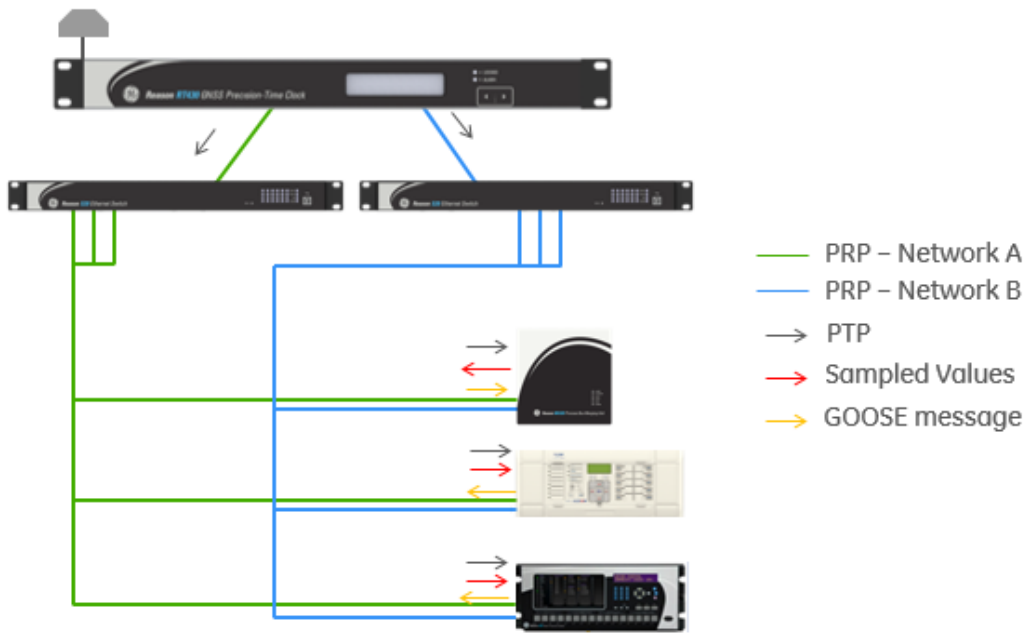

Figure 40: Process Bus application using PTP via the Station Bus network.

Application Example 5: Time Sync Expansion using RT411 and RT412

In applications where a higher number of TTL or ST outputs are required for IRIG-B/PPS, the RT411 is a cheap solution to expand the number of outputs from clocks. Furthermore, the RT412 can convert optical signals to electrical and vice versa, which is a great solution to distribute time synchronization. The next figure demonstrates an IRIG-B time distribution using only one clock plus a RT411 and many RT412, used in Automation & Control architectures.

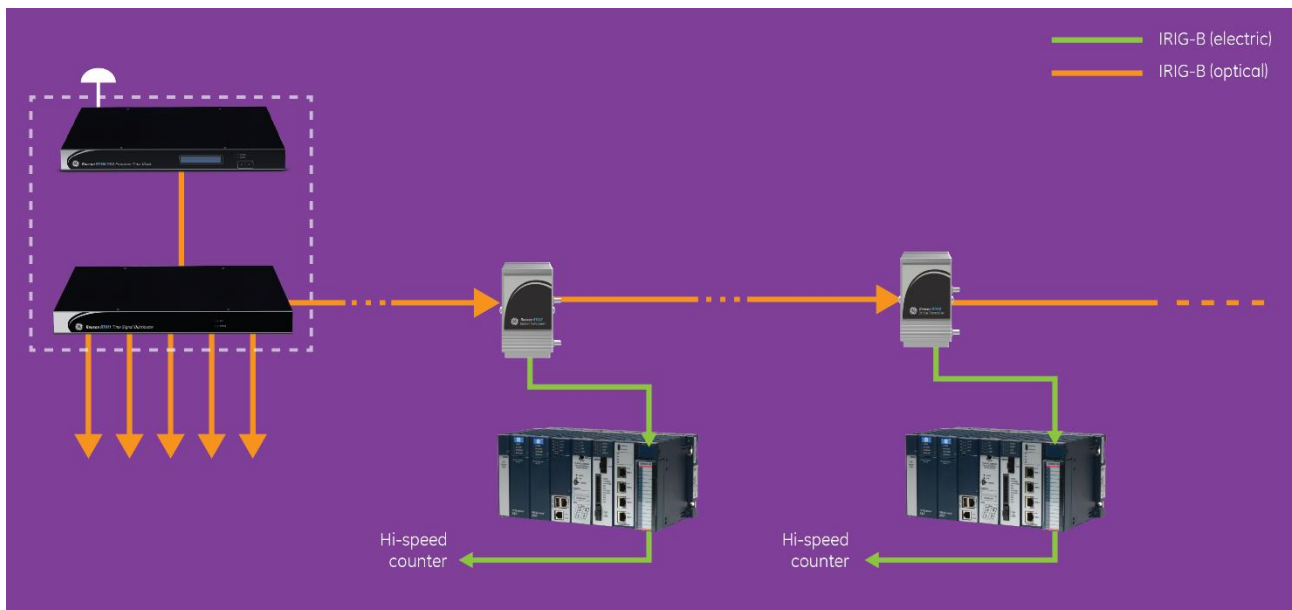

Figure 41: Time Sync expansion using RT411 and RT412

Appendix F – Kit Mounting for GNSS Antenna (Q065)

A kit mounting for walls (ordering code Q065) is available to install the GNSS antenna (code Q020) supplied by GE.

The kit mounting dimensions and composition are as follows.

Table 39: Dimensions specification of antenna kit mounting

Height	Body: 150 mm (5.9 in) Pipe: 500 mm (19.7 in)
Width (body)	181.7 mm (7.2 in)
Depth (body)	217.7 mm (8.6 in)

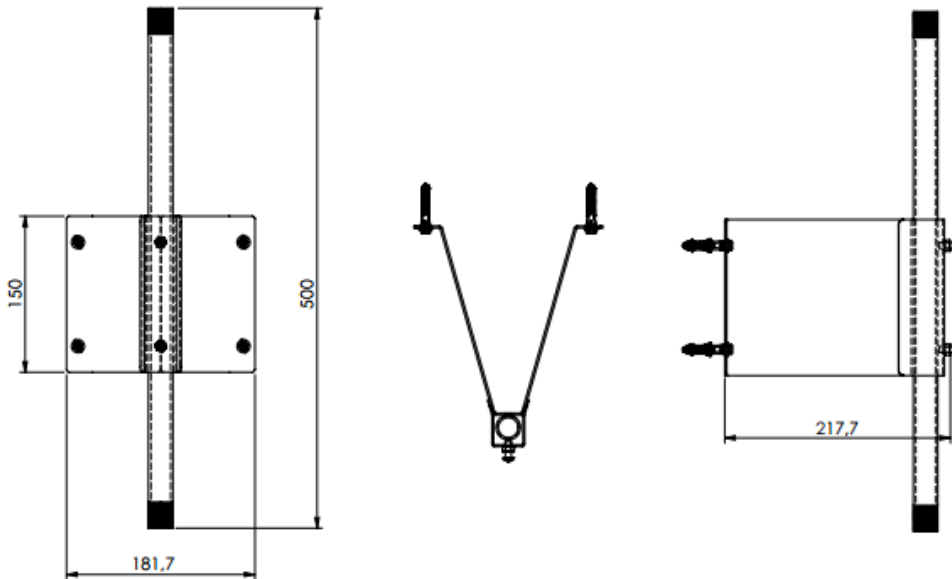

Figure 42: Dimensions of antenna kit mounting

Table 40: Description of items from kit mounting

Number 1	Main structure of kit mounting (Stainless steel)
Number 2	Phillip screws M6x16 (Stainless steel)
Number 3	S8 nylon plugs
Number 4	Self-tapping screw 3/16"x45 (Stainless steel)
Number 5	M6 Washer (Stainless steel)

Number 6	3/4" PVC pipe with 1.814 mm thread in both ends
----------	---

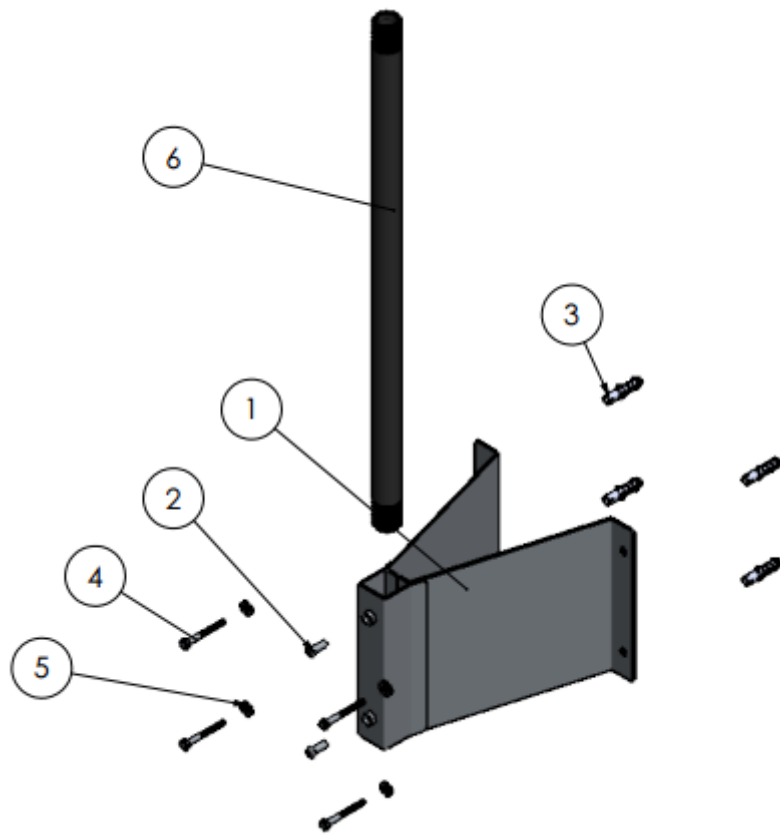

Figure 43: Items from antenna kit mounting