



PTC System Design with the TD220X

Version 0.2 - 2013-06-21

Tom Mayo
Ken Tuttle
Rich Place





PTC System Design with the TD220X

Version 0.2 - 2013-06-21

SUBSYSTEM CONFIGURATIONS

GE MDS is committed to providing a communications System for the PTC Application. GE MDS proposes providing our off-the-shelf TD220 radios and eNETL2T power amplifiers for integration into the overall system.

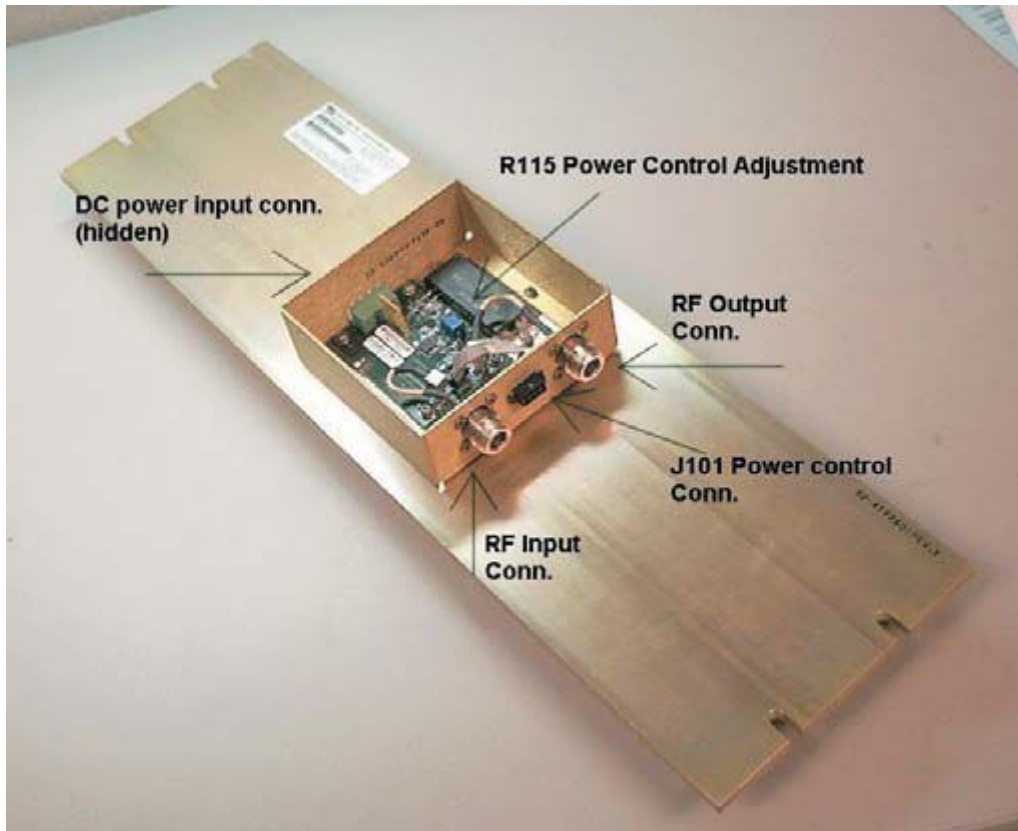

GE MDS eNETL2T

This solution employs our proven TD220 radios used by AMTRAK on their 100 miles of track near Niles, Michigan. The TD220X version implements a generic protocol (STFP) to permit an external Communications Manager to implement the upper portion of the TDMA MAC for the Commuter Rail PTC environment. STFP allows a Communications Manager to access the individual time slots within the over the air frame format.

While the Michigan ITCS system used broadcast messages and needed to support a small number of trains, the Commuter Rail PTC System uses point-to-point messaging and must handle a much greater number of trains.

The overall system context can be seen in the figure below.



PTC System Design with the TD220X

Version 0.2 - 2013-06-21

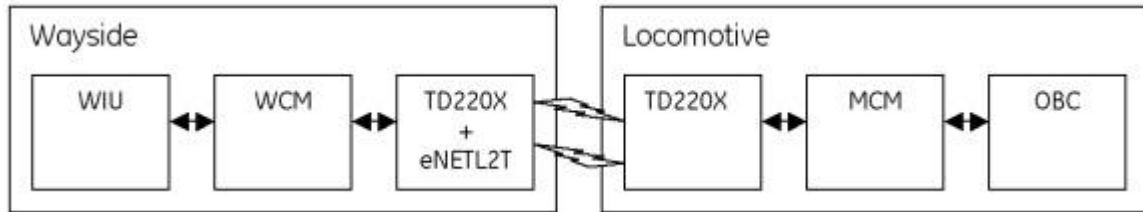

Commuter Rail Train Control Communications System

Hardware Configurations

GE MDS’s proposal includes TD220X radios and eNETL2T power amplifiers. As the project progresses, GE MDS can recommend duplexers, feedline, and antennas that are suitable for use in a complete system.

Simplex Base

The simplex base employs a single TD220X radio, eNETL2T power amplifier, and a feedline/antenna system. The WCM connects to the radio via Ethernet.

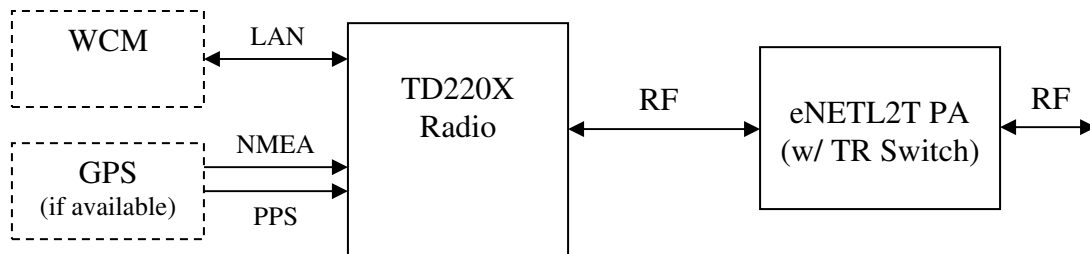

Half-Duplex Base

The half-duplex base employs a single TD220X radio, eNETL2T power amplifier, and a feedline/antenna system. The WCM connects to the radio via Ethernet. The block diagram for this configuration is the same as the Simplex Base.

Full-Duplex Base

The full-duplex base employs two TD220X radios (one transmitter and one receiver), one eNETL2T power amplifier, a duplexer, and a feedline/antenna system. The WCM connects to the radio via Ethernet.



PTC System Design with the TD220X

Version 0.2 - 2013-06-21

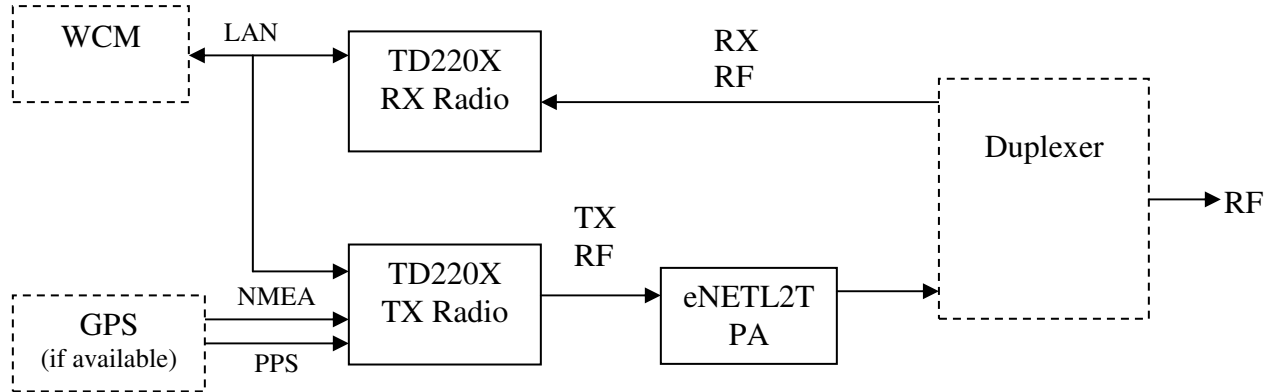

The transmit and receive frequencies of a full-duplex base need to be separated significantly so that the transmitter signal can be prevented from overloading the receiver. Typical frequency separation between transmit and receive on the 220 MHz band is 1 MHz. Duplexers providing significant isolation are typically four cavities taking up about 3 19" rack units.

Co-Located Bases

It may be desired to operate independent bases at the same site due to a large number of locomotives to be supported in a single area or the requirement for two railroads to operate in overlapping territory. Employing two independent base systems at the same site must be done with extreme care. There are two concerns: (1) the transmitter from one base could block the receiver of the other base from hearing its locomotives, and (2) a nearby locomotive working with one base could block the receiver of the other base from hearing its locomotives. The second concern is illustrated below.

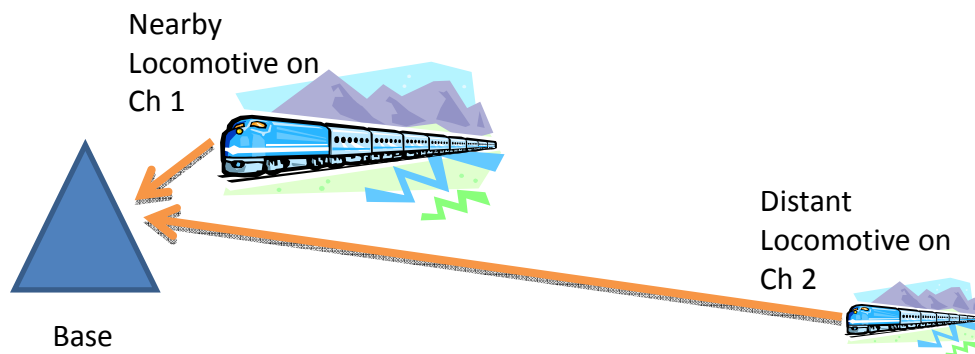

There are two schemes that can be used to address these concerns. The first is to coordinate the usage of time slots so (a) neither base expects to receive when either transmitter is active and (b) one base never expects to receive at the same time the other base's remotes are transmitting. This is done through intelligent slot allocation schemes and either pre-planned time slot division between railroads or software coordination between the WCMs.



PTC System Design with the TD220X

Version 0.2 - 2013-06-21

The second scheme is to provide enough isolation between units so that any transmitter can be active when any receiver expects to receive. The isolation-based scheme is problematic in that sufficient filter networks are physically large. Further, frequencies must be separated by a significant amount. For example, a co-location plan used in an RCL application in Houston, TX uses 217.8 MHz TX/218.8 MHz RX for one base and 220.10625 MHz TX/221.10625 MHz RX for the other. Note that 1 MHz separation is used between the associated transmitters and receivers, while the minimum separation between the independent receiver and transmitter is 1.30625 MHz. The filter network for this configuration takes up the better part of a six-foot high 19" rack. As can be easily seen from this example, it is much more desirable to employ a scheme where timeslots are not reused at the same site (i.e. the first scheme).

Mobile

The mobile configuration for the locomotive employs a single TD220X radio. The MCM connects to the radio via Ethernet.

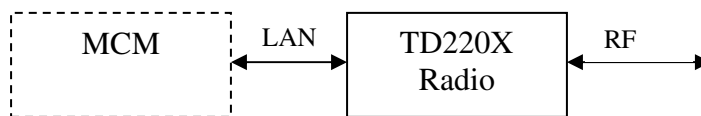

Diversity/Hot Standby Mobile

The diversity/hot standby mobile for the locomotive employs two TD220X radios. For diversity separate feedlines and antennas are used. For a hot standby configuration, a splitter/combiner is used to share a single feedline and antenna. The MCM connects via an Ethernet switch or two wired Ethernet ports to the two radios.

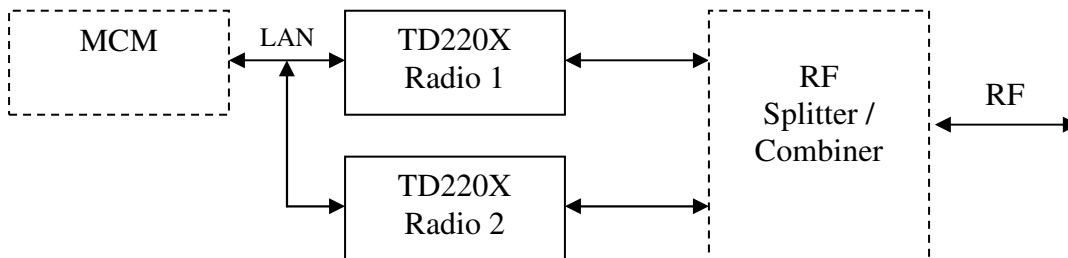



PTC System Design with the TD220X

Version 0.2 - 2013-06-21

TDMA MAC

The TD220 is a Time Division Multiple Access (TDMA) Radio. The radio divides each second into 8 equal length 125 ms time slots. The radio is able to transmit or receive one message in each time slot.

<----- 1 second ----->							
Time Slots							
1	2	3	4	5	6	7	8
125 ms	125 ms	125 ms	125 ms	125 ms	125 ms	125 ms	125 ms

Over the Air (OTA) Message Format

The OTA message is 148 bytes long. It consists of a 12-byte Header, a 117-byte payload area, a 2-byte CRC value, 16 bytes FEC Code Words and a Guard Byte.

TD220 TDMA Message structure				
Header	Payload	CRC	FEC Code Words	Guard Byte
12 Bytes	117 Bytes	2 Bytes	16 Bytes	1 Byte

The message header contains bit patterns and values allowing the radio to obtain bit and Byte synchronization. The Zone and Time Slot information allow Mobiles to synchronize their time slots using messages from Base radios. The Zone and Time Slot values are also passed up through the radio and are available to external equipment for system monitoring.

TD220 TDMA Header Structure					
Bit Sync	Byte Sync	Zone	Time Slot	Reserved	Payload Length
9 Bytes	4 Bits	4 Bits	3 Bits	5 Bits	1 Byte

Message Payload Area

The radio can concatenate smaller messages into the 117-byte payload space. These concatenated messages will be separated by the receiving radio and sent to the local equipment in separate STFP messages.



PTC System Design with the TD220X

Version 0.2 - 2013-06-21

TD220 117 Byte Payload Area

A Single 117 Byte Message

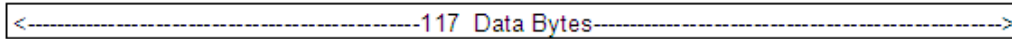

2-50 Bytes Messages

Len	Msg 1	Len	Msg 2	15 Bytes Unused
50	50 Data Bytes	50	50 Data Bytes	

Various Sized Messages

Len	Msg 1	Len	Msg 2	Len	Msg 3	29 Bytes Unused
25	25 Data Bytes	50	50 Data Bytes	10	10 Data Bytes	

TD220X Time Slot Usage

GE MDS proposes that the time slots be evenly divided between Downstream (Wayside to locomotive) and Upstream (Locomotive to Wayside) traffic. Two time slots (one downstream and one upstream) would be allocated to a locomotive while it was in a Waysides area. Using this method, with 8 time slots per second, 4 locomotives could be supported. This is pretty restrictive. To allow support for more than 4 locomotives, the radio also groups seconds into multi-second epochs. In this way, the time slots can be used to communicate with 16, 24 or more locomotives. The table below illustrates the time slots in a 3-second epoch.

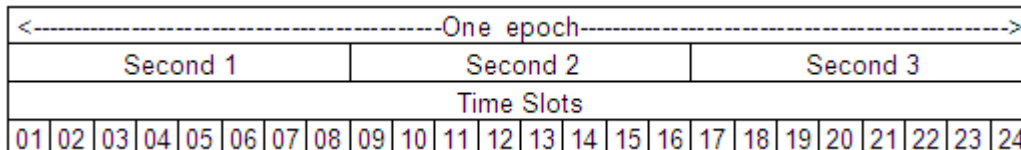

While the TD220 radios had a fixed epoch size of 3 seconds, the TD220X will allow the epoch size to be changed dynamically via SNMP. This will allow Waysides in congested areas to use a larger epoch to support more locomotives. To support this functionality, the Wayside Communications Manager (WCM) would send the epoch size to the locomotive when it first establishes a connection in the area. The Mobile Communications Manager (MCM) on the locomotive would then set the epoch size in the Mobile radio. This epoch size would be used for all communications while in this wayside area. The table below list the valid epoch sizes (the epoch size must divide into 60 evenly), the number of time slots per epoch, the number of time slots a remote would have to transmit in within a minute, the number of bytes a remote could transmit per minute and the relative increase or decrease in that byte count relative to a three second epoch.



PTC System Design with the TD220X

Version 0.2 - 2013-06-21

Seconds Per Epoch	Time Slots Per Epoch	Time Slots per Remote Per Minute	Bytes per Remote Per Minute	Bandwidth relative to 3-second epoch
1	8	60	7,020	300%
2	16	30	3,510	150%
3	24	20	2,340	100%
4	32	15	1,755	75%
5	40	12	1,404	60%
6	48	10	1,170	50%
10	80	6	702	30%
12	96	5	585	25%
15	120	4	468	20%
20	160	3	351	15%
30	240	2	234	10%

As can be seen in the table above, increasing the epoch size decreases the number of bytes that an individual remote may transmit per minute.

Continuing with the example of a 3-second epoch, this allows the radio to provide 24 uniquely identifiable time slots. Allocating 2 time slots per locomotive, this allows the wayside to communicate with 12 locomotive simultaneously using simplex or Half-Duplex radios both on the locomotive and at the Wayside. The number of locomotives is doubled to 24 if a Full-Duplex Base is used at the wayside.

The table below shows how the time Slots within a 3-second epoch are available for use by the Base and the Mobile in simplex, Half-Duplex and Full-Duplex mode.

TD220X Time Slot Usage

Simplex

	Frequency	Time Slots w/in Epoch
Base TX	E_b/m	01 02 03 04 05 06 07 08 09 10 11 12
Mobile TX	E_b/m	13 14 15 16 17 18 19 20 21 22 23 24

Half-Duplex

	Frequency	Time Slots w/in Epoch
Base TX	E_b	01 02 03 04 05 06 07 08 09 10 11 12
Mobile TX	F_m	13 14 15 16 17 18 19 20 21 22 23 24

Full-Duplex

	Frequency	Time Slots
Base TX	E_b	01 02 03 04 05 06 07 08 09 10 11 12 13 14 15 16 17 18 19 20 21 22 23 24
Mobile TX	F_m	01 02 03 04 05 06 07 08 09 10 11 12 13 14 15 16 17 18 19 20 21 22 23 24



PTC System Design with the TD220X

Version 0.2 - 2013-06-21

The table below shows the number of locomotive that can be supported, based on the chosen epoch size.

Seconds Per Epoch	Time Slots Per Epoch	Locomotives Supported	
		Simplex or Half Duplex	Full Duplex
1	8	4	8
2	16	8	16
3	24	12	24
4	32	16	32
5	40	20	40
6	48	24	48
10	80	40	80
12	96	48	96
15	120	60	120
20	160	80	160
30	240	120	240

Using the TD220X radio, each Base location will have 1 time slot (117 bytes) per epoch to transmit messages to a specific Locomotive and each locomotive will have 1 time slot per epoch to transmit messages to the Base. This gives the Base and each Locomotive 2,340 bytes of payload in each direction every minute (assuming a 3-second epoch).

A Base radio operating in Half-Duplex mode can transmit in 12 time slots and receive in 12 time slots per epoch. This allows a Half-Duplex Base radio to support up to 12 locomotives simultaneously. Each of the 12 locomotives can have a dedicated time slot to send messages to the Base radio and a dedicated time slot to receive messages from the Base radio.

A Base radio operating in Full-Duplex mode can transmit in 24 time slots and receive in 24 time slots per epoch. This allows a Full-Duplex Base radio to support up to 24 locomotives simultaneously. Each of the 24 locomotives can have a dedicated time Slot to send messages to the Base radio and a dedicated time slot to receive messages from the Base radio.

Additional Bandwidth

Any time a TD220X radio is not transmitting a message, it switches to the default receive frequency and will receive all message sent by the Base radio. The Mobile radio will package these messages into STFP packets and send them to Mobile Communications Manager. The MCM must decide the appropriate action to take for each message received.



PTC System Design with the TD220X

Version 0.2 - 2013-06-21

This feature can be used to gain downstream bandwidth. The Wayside Communications Manager can transmit “general interest” message in any Base transmit time slot that has some room in it. Administrative messages such as a time slot allocation table or a time slot request could be sent at any time.

There may also be ACSES messages of “general interest” to all locomotives in the area.

STFP PROTOCOL

To provide the most flexibility, the TD220X radio acts as a “simple” conduit for messages between Wayside and locomotive equipment. “Upper level” Media Access Controller (MAC) logic and functionality are performed by equipment external to the TD220X radio. The TD220X radio supports the GE MDS open STFP protocol that allows ACSES equipment to use the TD220X radios to transmit and receive messages over the air.

The radio provides the lower level Media Access Controller (MAC) functionality of the communications link between the Wayside equipment and the equipment on the Locomotive. This lower level MAC functionality includes accurately tracking the multi-second epoch and TDMA time slots, passing payload received over the air to a configured IP address and transmitting payload received via UDP using the specified time slot within the epoch, frequency and output power level.

The radio also implements Forward Error Correction (FEC) to detect and correct errors introduced due to the movement of the locomotive. Before each message is transmitted over the air, the transmitting radio calculates and appends a 2 byte CRC and 16 bytes of FEC code words to the message. The FEC code words allow the receiving radio to detect and correct bit errors within the message while the CRC allows the receiving radio to determine if all bit errors have been corrected and, therefore, the message is correct.

The upper level MAC functionality is performed by equipment external to the TD220X radio. This functionality includes:

1. Ensuring that messages get sent in the first timeslot of a second periodically to permit mobiles to synchronize their TDMA slots with the base.
2. Managing time slot usage (possibly by using dynamic time slot assignment).
3. Sending ACSES Payload to the radio via STFP message to instruct the radio when (second and time slot) and how (Frequency and Output Power Level) the payload should be transmitted.
4. Configure the radio’s receive frequency.

At the Wayside, the Wayside Interface Unit (WIU) contains the controlling logic for the locomotives within the area of this wayside. The WIU send ACSES messages to the Wayside Communications Manager (WCM). The WCM then determines which time slot to use to communicate with the chosen locomotive. It constructs the appropriate STFP message and sends it to the TD220X Base radio. The Base radio transmits the ACSES



PTC System Design with the TD220X

Version 0.2 - 2013-06-21

payload using the Second, Time slot, Frequency and Power specified in the STFP message.

On the locomotive, the Mobile radio receives the message over the air and passes it onto the Mobile Communications Manager (MCM) in an STFP message. The MCM then converts the message to an ACSES message and passes it onto the On Board Computer (OBC).

Messages from the OBC to the WIU will use the reverse path.

RADIO SYNCHRONIZATION

Both Base and Mobile radios must have precisely synchronized clocks in order for the TDMA communications to work properly. The system has the potential for sending a message every time slot of every second with only one 1 millisecond separating the messages. A radio transmitting at an incorrect time can disrupt all PTC communications within the area.

Base Radio Timing

The Base radios are the master timekeepers of the TD220X radio system. In turn, Base radios rely on timing information from GPS units for their precise synchronization. A Base radio uses the Time Of Day (TOD) information from the GPS NMEA GGA sentence to precisely set its System Clock so it can accurately determine the second within an epoch. The Base radio uses the GPS Pulse Per Second (PPS) signal to precisely track the start of each second. The start of each time slot within a second is then based on this start of second event.

Base Radios without GPS Access

To support wayside locations where GPS units cannot receive sufficient satellite signals to work (such as in long tunnels), the TD220X Base radios will implement the Precision Time Protocol (PTP v2, IEEE 1588), which will allow a Base Radio without GPS access to establish accurate timing, based on IP messages exchanged with a PTP Grandmaster device. Any device that supports PTP V2 may be used as the Grandmaster (such as the Spectracom SecureSync). This Grandmaster device would need to be positioned such that it could get a GPS Lock. A LAN connection is required between the Base radio and the PTP Grandmaster to support this functionality.

Mobile Radio Synchronization

Mobile radios will not have access to GPS information. The TD220X Mobile radios synchronize based upon the receipt of a message from a Base radio in the first time slot of any second. The Mobile uses the header information of these Beacons to synchronize their TOD and time slot clock. The payload of these Beacon messages is not used as a part of this synchronization. Only the header information is used.



PTC System Design with the TD220X

Version 0.2 - 2013-06-21

It is important that the Wayside Communications Manager send a message (any message) in the first time slot of a second periodically. The Mobile radio will lose synchronization lock, go into an alarm state and stop transmitting if it does not receive a Beacon message every N seconds where N is coded as 6 seconds in our current implementation.

FREQUENCY ASSIGNMENT

Careful radio system planning is required to optimize performance and minimize co-channel interference. Base TX frequencies should be taken from one end of the available frequency range while Mobile TX frequencies should be taken from the other. Adjacent bases should be assigned frequencies that are as far apart from one another as practical.

In coordinating channel use for coverage of a PTC system, many spatial channel assignment schemes have been introduced. Most schemes employ omnidirectional antennas for even radio coverage and/or a single channel per base. A scheme that deserves some thought is one that employs directional antennas and two or more channels at each base site to allow closer channel reuse by counting on the front to back ratio provided by directional antennas.

As shown in the figure below, omnidirectional antennas force distant spacing between sites using the same channel. This is to accommodate a 20 dB C/I ratio required to ensure the desired base transmission is not blocked at the mobile receiver. In the example in the figure, the configuration must be such that the distance from mobile a to undesired base B is more than seven times the distance from a to desired base A.

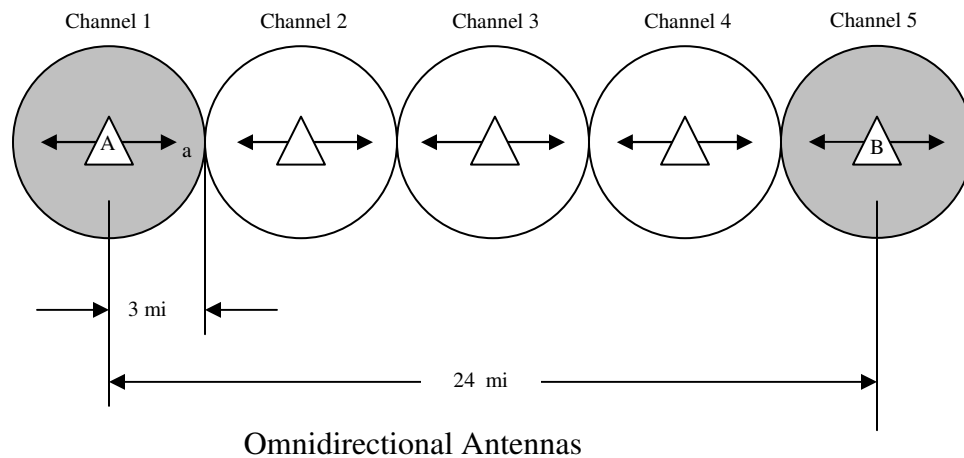

A superior scheme would be to employ directional antennas at each base site. Typical front to back (FB) ratios of 17 dB can be achieved with Yagis. The trick is to point the Yagi for a given channel only in one direction and not both. With this scheme, the back of the Yagi antenna rejects the next use of the same frequency allowing a 17 dB benefit (from the FB ratio) and therefore closer spacing. This almost eliminates the blocking issue as 17 dB is close to the 20 dB C/I ratio desired, however to provide margin, two channels can be used. As shown in figure 2, only 2 channels are needed to cover any



PTC System Design with the TD220X

Version 0.2 - 2013-06-21

arbitrary length of track. Again, mobile “a” is operating with Base A on channel 1, and Base B is undesired, but also uses channel 1.

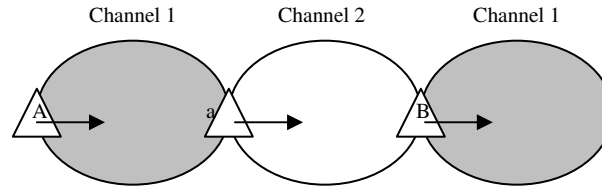

Directional Antennas with End Bases – 2 Channels Needed

Because coverage may be marginal with Yagis facing only in one direction, it is possible to have two Yagis per site but with different channels for each Yagi to maintain the benefit of the FB ratio per channel. In this scenario, it will be necessary to coordinate the two base radios so that they transmit at the same times. At first thought this seems to reduce the ability to support enough mobiles, but upon further consideration, a half-duplex GE MDS TD220 base can support 12 mobiles with a simple MAC, so two half duplex base can support 24 locomotives, which meets the needs of the application.

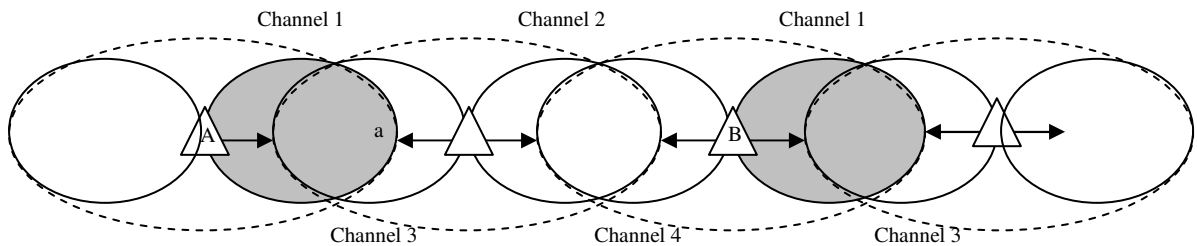

Directional Antennas with Center Bases – 4 Channels Needed

In Figure 3 above, Bases A and B both use channel 1 on right-facing directional antennas. Base B’s signals are rejected to the left where Mobile “a” operates. Mobile “a” is operating with Base A, and Base B is undesired.

In some situations, bases are so close that they essentially cover the same space. An idea to prevent using additional channels are to gang several interlockings together using a 900 MHz GE MDS entraNET radio with one 220 MHz base site to support them all. This requires that the number of mobiles supported for all ganged interlockings does not exceed the 220 MHz capacity for one site. In some situations, this may not be true, so additional 220 MHz channels can be used sparingly to fill specific needs.



PTC System Design with the TD220X

Version 0.2 - 2013-06-21

In some areas, bases are closely spaced and the topology is 2D vs. linear along a single track. In this case, a cell scheme can be employed, still only requiring 3 channels to cover an arbitrary 2D area.

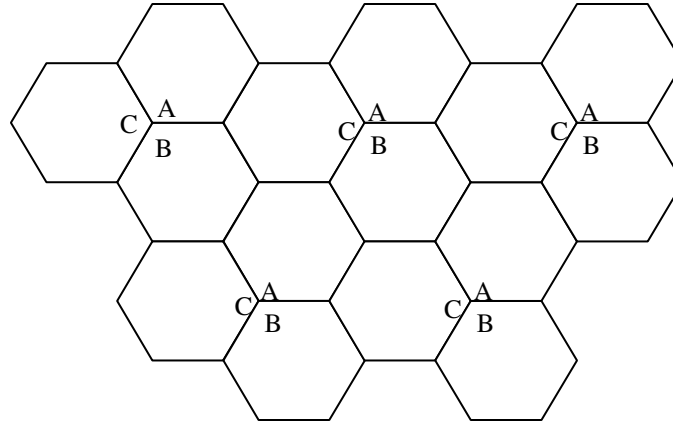

2D Coverage with Directional Antennas at Center Bases – 3 Channels Needed

The beauty of the 2D coverage is that you actually need fewer channels in this area because there is natural isolation between cells covered by a given channel in a given direction.

TRAFFIC CAPACITY ANALYSIS

Commuter Rail Traffic Description – Per Locomotive

In the following table, we sum the different types of traffic indicated in the Commuter Rail environment to obtain an overall picture of the number of Bytes per minute required.

	Source	Locomotive	Base
Interlocking Status	Bytes/n sec	36/6	58/6
	Bytes/1 sec	6.0	9.7
TSR List	Bytes/n sec	56/30	120/30
	Bytes/1 sec	2.0	4.0
Maint Alarm	Bytes/n sec	56/60	56/60
	Bytes/1 sec	1	1

Total Traffic Per locomotive	Bytes/n sec	9.0	14.7
	Bytes/epoch	27	44.1
	Bytes/min	540	882

Commuter Rail Traffic Description – Aggregate

The following table accounts for all the locomotives supported and sums the base and locomotive transmit and receive traffic for all locomotives.



PTC System Design with the TD220X

Version 0.2 - 2013-06-21

	Locomotives	Bytes/min per Locomotive	Bytes/min
Base RX Traffic for 12 locomotives	12	540	6480
Base TX Traffic for 12 locomotives	12	882	10584
Base RX Traffic for 24 locomotives	24	540	12960
Base TX Traffic for 24 locomotives	24	882	21168

Capacity of the GE MDS Proposed TD220X Radio

The following table sums the traffic capacity provided by the GE MDS TD220X TDMA scheme.

	Total capacity		
	Bytes/Sec	Bytes per EPOCH	Bytes/Min
Half-Duplex Base RX Capacity	468	1404	28080
Half-Duplex Base TX Capacity	468	1404	28080
Full-Duplex Base RX Capacity	936	2808	56160
Full-Duplex Base TX Capacity	936	2808	56160
Simplex/Half-Duplex Mobile		117	2340

Comparison of Commuter Rail Traffic Requirement vs. TD220X Capacity

As can be seen in the following table, the TD220X provides sufficient capacity for the traffic model provided for the Commuter Rail environment.

	Commuter Rail Traffic Requirement	TD220X Capacity (assuming a 3-second epoch)	Excess Capacity
Source	Bytes/Min.	Bytes/Min	%
Locomotive	540	2340	76.92%
Base RX Traffic for 12 locomotives	6480	28080	76.92%
Base TX Traffic for 12 Locomotives	10584	28080	62.31%
Base RX Traffic for 24 locomotives	12960	56160	76.92%
Base TX Traffic for 24 Locomotives	21168	56160	62.31%



APPLICATION OF FEC TO WIRELESS RAIL COMMUNICATIONS

The combination of multipath and motion is especially harmful to data communications. Multipath causes the signal strength to vary dramatically from one location to another, just a few feet apart. Motion introduces clicks on the demodulated waveform due to phase changes associated with the varying signal level. Reed Solomon Block coding greatly improves reliability of wireless data communication links. The TD220 radio employs Reed Solomon Forward Error Correction.

The plot below captured the signal strength while traveling 45 mph on the rail within two miles of a 60 foot tower in Niles, MI.

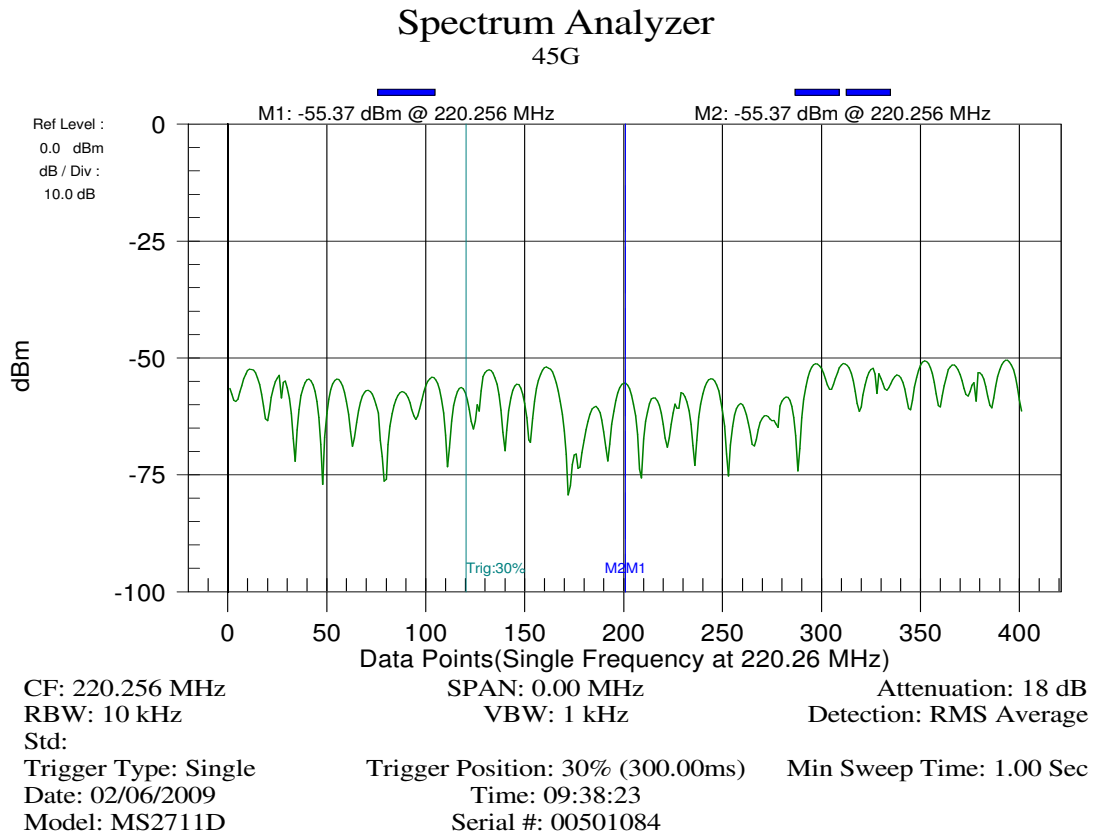

1 second sweep at 220 MHz

Without FEC, the combination of multipath and motion introduces bit errors, resulting in an irreducible error rate. No matter how strong the signal is, there will be a high residual error rate. This is illustrated in the following figure.



PTC System Design with the TD220X

Version 0.2 - 2013-06-21

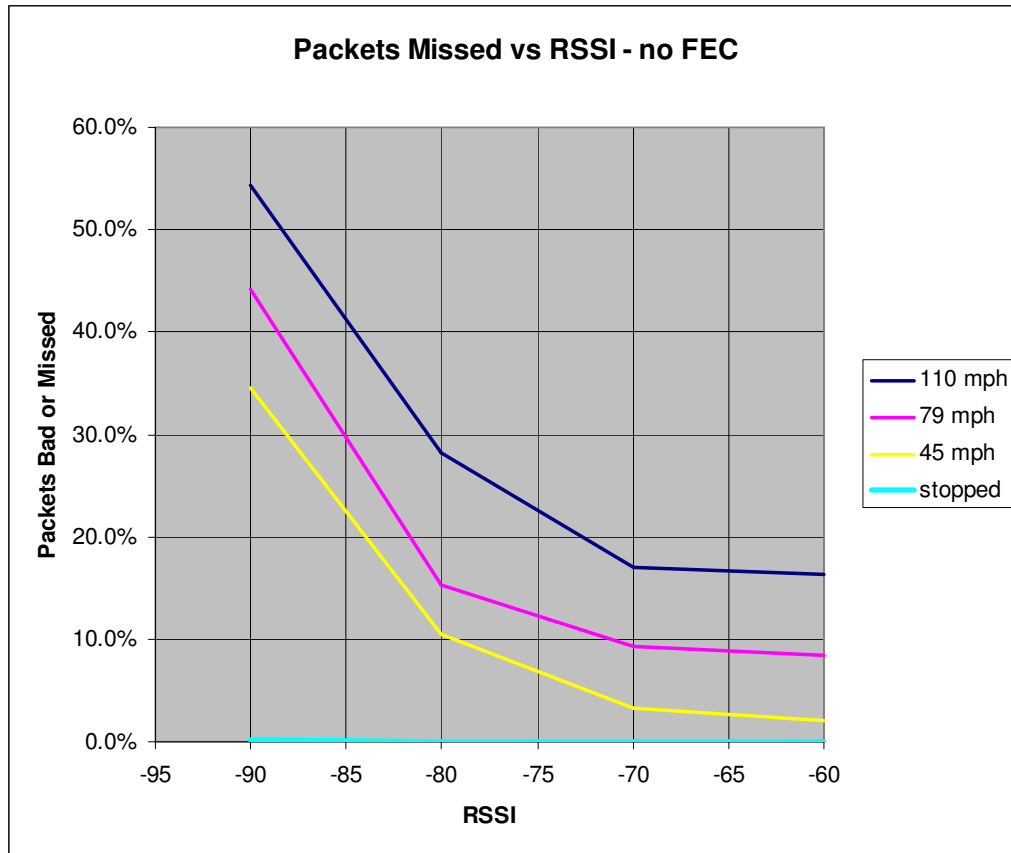

Receiving 8 packets per second, 133 bytes each, at 9600 bps through a channel emulator with Rayleigh fading.

Note, for example, at a reasonably strong signal of -70 dBm the error rate goes from no errors at zero mph to 5% packet loss even as slow as 45 mph.

Forward Error Correction makes an impressive improvement. We use a Reed Solomon code adding 16 correction bytes to every 117 bytes of payload. The following figure compares performance without FEC and with FEC added.



PTC System Design with the TD220X

Version 0.2 - 2013-06-21

Packet Loss% Without FEC

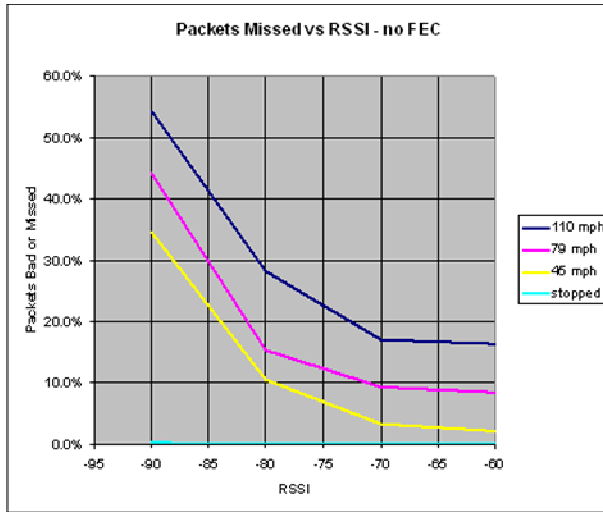

Packet Loss% With FEC

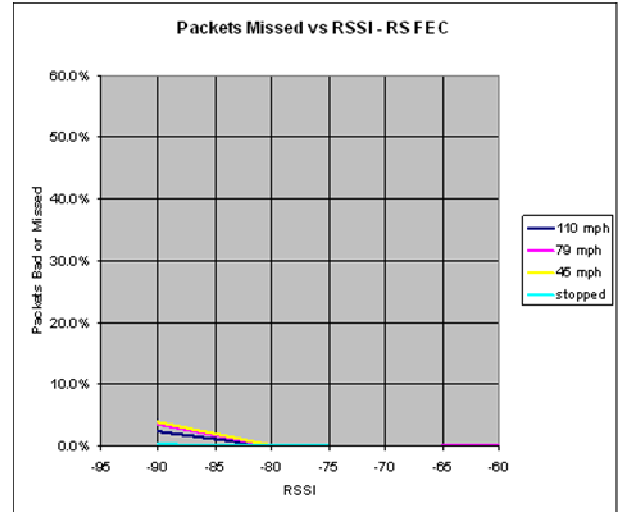

Receiving 8 packets per second, 133 bytes each, at 9600 bps through a channel emulator with Rayleigh fading.

As can be seen, the effective performance is greatly improved with all speeds. The basic zero motion Bit Error Rate will be better as well. The following table illustrates this point.

Measured results on a GE MDS TD220 radio:

RSSI	Packet Loss%	Packet Loss%
	No FEC	Reed Solomon FEC
-90 dBm	0%	0%
-100 dBm	27%	0%
-103 dBm	88%	2%
-110 dBm	100%	81%



SUGGESTED TIME SLOT ALLOCATION METHOD

While GE MDS does not intend on implementing the slot allocation method described below, we have prepared this information to serve as a starting point for a system integrator's development.

The GE MDS TD220X radio divides each second into 8 equal Time Slots, each 125 ms long. The radio is able to send or receive a message in each time slot.

Although it has been decided to enhance the radio to support variable sized epochs (as explained in the proposal), this paper will assume that 3-second epoch is used. Changing the epoch size will change the number of time slots available to be allocated but the allocation method will not change.

The radio supports the concept of a three-second epoch. This provides 24 Time slots in each epoch. Using this TDMA configuration, a Simplex or Half-Duplex Base radio can support up to 12 locomotives simultaneously and a Full-Duplex Base radio can support up to 24 locomotives simultaneously.

In this time slot allocation method, the communications for each locomotive utilizes 2 time slots within the epoch. One time slot is for communication from the wayside to the locomotive, the other is used for communications from the locomotive to the wayside.

Wayside functionality

The Wayside Communications Manager (WCM) or other equipment at the Wayside locations will transmit a Slot Allocation Map message, through the Base radio, at least once a second. This should be a fairly small message that can be sent in any time slot that has room. As a Mobile radio is in Receive Mode if it is not transmitting, Mobiles will receive and process all messages sent by the Base. The Slot Allocation message will contain a Slot Allocation bit map. Each bit in the bit map will represent the corresponding time slot within an epoch. If the bit is set, the corresponding time slot is allocated for use by a locomotive. If the Bit is clear, the corresponding time slot is not allocated and is available to be requested by a locomotive.

Wayside equipment using a Simplex or Half-Duplex Base radio will always report the first 12 time slots as allocated. The Simplex and Half-Duplex radio will use these time slots to transmit to the Mobiles. These time slots will be available in the Full-Duplex environment as the Full-Duplex Base will be able to both transmit and receive in all time slots.



PTC System Design with the TD220X

Version 0.2 - 2013-06-21

Initial Simplex and Half-Duplex Slot Allocation Bit Map																							
1	2	3	4	5	6	7	8	9	10	11	12	13	14	15	16	17	18	19	20	21	22	23	24
1	1	1	1	1	1	1	1	1	1	1	1	0	0	0	0	0	0	0	0	0	0	0	0

Initial Full-Duplex Slot Allocation Bit Map																							
1	2	3	4	5	6	7	8	9	10	11	12	13	14	15	16	17	18	19	20	21	22	23	24
0	0	0	0	0	0	0	0	0	0	0	0	0	0	0	0	0	0	0	0	0	0	0	0

Each wayside maintains its own slot assignment information. When the wayside equipment receives a request for a time slot, it checks its own Slot Allocation Map to make sure that the slot isn't already allocated to a different mobile. If the time slot is not allocated, the wayside equipment grants the slot request, setting the bit in the Slot Allocation Map and sending an acknowledgement (ACK) to the locomotive. If the slot has already been allocated, a Negative Acknowledgement (NAK) is sent to the locomotive.

A Base TX time slot is allocated at the same time that the Mobile TX time slot is allocated. The Base TX time slot allocated to a mobile depends upon the Mobile TX time slot allocated to the mobile. The Base TX time slot is the time slot 1.5 seconds (or 12 timeslots) before the Mobile TX time slot so, if the Mobile TX time slot is the 19th time slot, the wayside equipment will allocate time slot 7 to transmit messages to that Mobile.

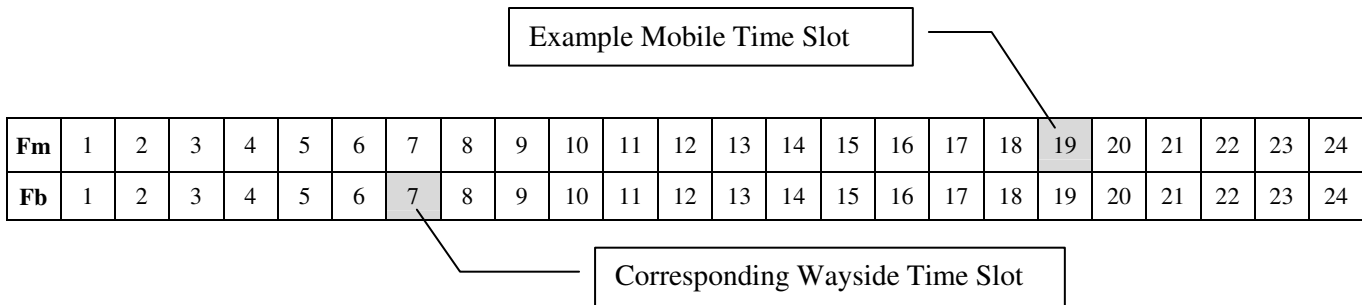

Both the Mobile and Base time slots are freed after the wayside equipment has not received a message from the locomotive for 30 seconds. This frees up Time Slots used by locomotives that have entered a new area and have stopped communicating with this Base location.

Locomotive functionality

As a locomotive enters an area, the Mobile Communications Manager (MCM) instructs the radio on what receive frequency to use. The radio will then forward all over the air traffic (including the Slot Allocation Bit Map) to the MCM. The MCM then selects a free time slot from the bitmap and sends a slot request to the wayside.



PTC System Design with the TD220X

Version 0.2 - 2013-06-21

If the MCM receives an ACK, it starts using the time slot, directing the radio to transmit messages in that slot and assuring that the radio is on the correct RX frequency otherwise.

Once a time slot has been allocated, the MCM must assure that at least one message is sent every 10 seconds. This assures that the WCM will not free up the time slot due to a timeout.

If a NAK is received, it indicates that the slot allocation request did not succeed. The MCM must select a different free time slot, based on the Slot Allocation Bit Map, and send slot request to the wayside.

It is very unlikely that a slot request will fail as the slot allocation bit map is transmitted multiple times a second and it's unlikely that two locomotives will:

- Enter an area and request a time slot within the same three second epoch and
- Randomly choose the same time slot from the available time slots.

The epoch size must be designed for a given area so that the number of locomotives possible in the area is supported by the number of time slots in the epoch.

Once the time slot has been allocated, the MCM must monitor the Slot Allocation Bit Map to assure that the time slot continues to indicate that it is allocated. The MCM must re-request a time slot if the time slot it was using is shown as free (this may occur if the wayside equipment is reset for any reason).

A MCM may send a message to the wayside to explicitly free up the time slot if it is going to enter a period when it will not need to communicate with the wayside.



PTC System Design with the TD220X

Version 0.2 - 2013-06-21

Change Log

Version	Changes	Author	Date
0.1	Initial Release	T. Mayo	2011-11-29
0.2	Removed confidentiality note in footer	T. Mayo	2013-06-21