

Grid Solutions

# GE VERNOVA TRANQUELL SURGE ARRESTERS

Product Selection Guide

IEC Line Discharge  
Classes with 2, 3, and 4 Polymer Housings



## GE Vernova Surge Protection

The performance and reliability of today's electric power systems can be enhanced with the unique characteristics of GE Vernova's Tranquell™ surge arrester products. Since introducing the world's first metal oxide arrester in 1976, offering new concepts in surge arrester design and application, GE Vernova has developed and applied metal oxide technology for a variety of traditional and special applications. GE Vernova offers one of the most comprehensive range of surge arrester products in the world today; from distribution class to EHV arresters up to 612kV ratings as well as high energy varistors for series compensation applications.



GE VERNOVA

# Table of Contents

Introduction .....	3
General Arrester Information .....	4
Polymer Housed Arresters .....	5
<b>9L12PP (Class 2)</b>	
9L12PP Ordering Systems .....	?
9L12PP Protective Characteristics .....	6
9L12PP Physical Characteristics .....	7
9L12PP Mounting Arrangements .....	8
9L12PP Terminals .....	8
<b>9L11XP (Class 3)</b>	
9L11XP Protective Characteristics .....	9
9L11XP Mounting Arrangements .....	9
9L11XP Physical Characteristics .....	10
9L11XP Terminals .....	8
<b>Polymer Class 3</b>	
Polymer Class 3 Physical Characteristics .....	13
Polymer Class 3 Protective Characteristics .....	16
Polymer Class 3 Pollution Levels .....	?
<b>Polymer Class 4</b>	
Polymer Class 4 Physical Characteristics .....	18
Polymer Class 4 Protective Characteristics .....	21
Polymer Class 4 Pollution Levels .....	?
Surge Counters .....	?

## Warranty

GE Vernova warrants all products sold by it to be merchantable (as such term is defined in the Uniform Commercial Code) and to be free from defects in material and workmanship. Buyer must notify the Company promptly of any claim under this warranty. The Buyer's exclusive remedy for breach of this warranty shall be the repair or replacement, F.O.B. factory, at the Company's option, of any product defective under the warranty which is returned to the Company within one year from the date of shipment. NO OTHER WARRANTY, WHETHER EXPRESS OR ARISING BY COPERATION OF LAW, COURSE OF DEALING, USAGE OF TRADE OR OTHERWISE IMPLIED, SHALL EXIST IN CONNECTION WITH THE COMPANY'S PRODUCTS OR ANY SALE OR USE THEREOF. The Company shall in no event be liable for any loss of profits or any consequential or special damages incurred by Buyer. The company's warranty shall run only to the first Buyer of a product from the Company, from the Company's distributor, or from an original equipment manufacturer reselling the Company's product, and is non-assignable and

non-transferable and shall be of no force and effect if asserted by any person other than such first Buyer. This warranty applies only to the use of the product as intended by Seller and does not cover any misapplication or misuse of said product.

## Warranty – Application

GE Vernova does not warrant the accuracy of and results from product or system performance recommendations resulting from any engineering analysis or study. This applies regardless of whether a charge is made for the recommendation, or if it is provided free of charge.

Responsibility for selection of the proper product or application rests solely with the purchaser. In the event of errors or inaccuracies determined to be caused by GE Vernova, its liability will be limited to the re-performance of any such analysis or study.

*NOTE: Because GE Vernova has a policy of continuous product improvement, we reserve the right to change design and specifications without notice.*

## Introduction

GE Vernova has been producing high voltage surge arresters since the 1950's and offers a wide variety of Tranquell metal oxide gapless arresters designed to protect transformers, switchgear, and other equipment from switching and lightning surges. These arresters meet or exceed all requirements of the most current IEC standard and can be selected to match a range of contamination and energy requirements. Table 1 illustrates the GE Vernova offerings. This catalog focuses on polymer arresters.

**Table 1: GE Vernova Catalog Offerings\***

ARRESTER TYPE*	LINE DISCHARGE CLASS	HOUSING MATERIAL
9L12PP	2	EDPM/Silicone
9L11XP	3	EDPM/Silicone
9L11CMA, CHA, CVA: S3	3	Silicone
9L11CMA, CHA, CVA: S4	4	Silicone
9L11ZMA, ZHA, ZVA: S3	3	Porcelain
9L11ZMA, ZHA, ZVA: S4	4	Porcelain
9L11ZMA, ZHA, ZVA: S5	5	Porcelain

\* The **M**, **H**, and **V** in catalog number indicates the pollution level of Medium ( $\geq 20$  mm per kV Um) Heavy ( $\geq 25$  mm per kV Um) and Very heavy ( $\geq 31$  mm per kV Um).

### Dedication to Quality

GE Vernova's Quality Management System complies with ISO 9001:2008 and maintains stringent testing controls in accordance with IEC 60099-4 to ensure that the customer receives high quality with every product. Quality Assurance tests are performed on every batch of Metal-Oxide Varistor (MOV) blocks. The routine and design tests listed below, in addition to highly controlled manufacturing processes, ensure that GE Vernova products demonstrate a superior level of quality.

### MOV Block Routine Tests

**Physical Inspection** – Visual inspections are performed at several steps of the block manufacturing process.

**Rated Energy Test** – This procedure confirms the energy capability of each zinc oxide disc element.

**Residual Voltage Test** – Every block undergoes an 8/20 current wave impulse to verify its V-I characteristics.

**Watts Loss Test** – This test measures the AC watts loss and capacitive current characteristics of the disc.

### MOV Block Batch QA Tests

**Square Wave Energy Test** – Performed on a 5 disc sample from each batch, this test is performed to quantify the batch energy capacity.

**High Current Test** – Each 5 disc sample is subjected to two high current discharges of the same polarity to ensure current characteristics.

**A/C Life Test** – The discs are placed under test conditions for a minimum of 250 hours to verify performance.



### Arrester Routine Tests

**Physical Inspection** – Every molded rubber part, block, wrap module, brackets and completed unit is visually examined to reject defective products.

**Reference Voltage Test** – This test measures the voltage once a predetermined maximum peak current is reached.

**Partial Discharge Test** – This test ensures that the partial discharge level of the arrester does not exceed a level of 10 pC.

**Residual Voltage** – Tested on individual discs.

### Arrester Type Tests

**Testing Compliant with IEC 60099-4 Including:**

- Insulation withstand tests on housing
- Residual voltage tests
- Long-duration current impulse withstand
- Operating duty tests
- Short circuit tests
- Internal partial discharge tests

# General Arrester Information

## GE Vernova General Arrester Information for Product Selection

Table 1: Energy and Strength

TYPE	IEC CLASS	NOMINAL DISCHARGE CURRENT kA	PRESSURE RELIEF RATING kA	ENERGY CAPABILITY SINGLE (4ms IMPULSE) kJ/ kV - Uc	ENERGY CAPABILITY SINGLE (4ms IMPULSE) kJ/kV - Ur	ENERGY CAPABILITY 2-SHOT (1 MINUTE THERMAL) kJ/ kV - Uc	ENERGY CAPABILITY 2-SHOT (1 MINUTE THERMAL) KJ/ kV - Ur	CANTILEVER STRENGTH (N.m)	CANTILEVER STRENGTH
EDPM/Si	2	10	40	3.4	2.8	6.4	5.1	180	MPSL
EDPM/Si	3	10	63	4.9	4.0	9.0	7.2	2,260	MPSL
Porcelain S3	3	10	63	5.1	4.1	9.2	7.3	8,000	SSL
Silicone S3	3	10	63	5.1	4.1	8.5	6.8	8,000	SSL
Porcelain S4	4	20	63	9.2	7.4	13.3	10.6	17,000	SSL
Silicone S4	4	20	63	9.2	7.4	12.9	10.3	8,000	SSL
Porcelain S5	5	20	63	16.6	13.0	19.8	15.8	31,000	SSL

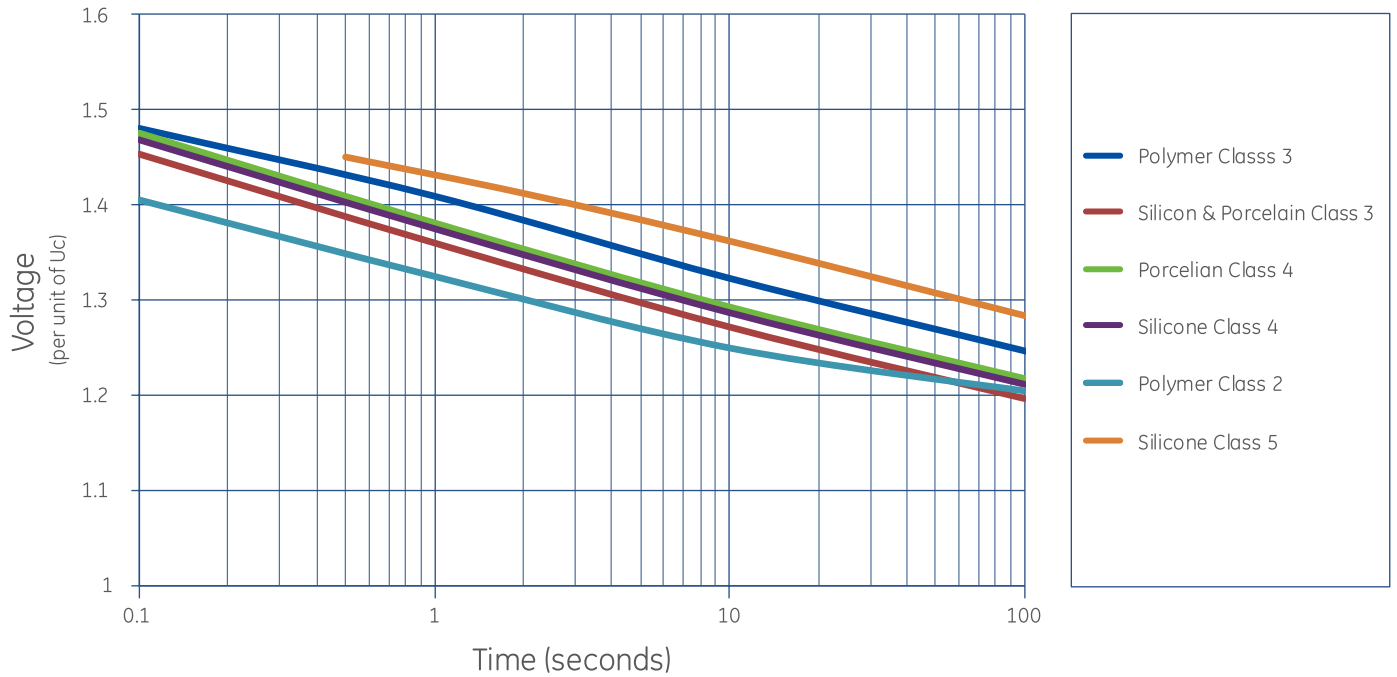
All GE Vernova IEC arresters exceed the pressure relief requirements of IEC 60099-4. 2-shot Energy Capability based on minimum values in IEC Operating Duty test. Actual values are typically higher.

### Temporary Over-Voltage Capability

GE Vernova Tranquell arresters are gapless and consist of a column of metal-oxide blocks connected between line and ground. The blocks can withstand a significant power frequency overvoltage for a limited time, depending on the magnitude of any immediately preceding surge duty. This duty can be the result of

switching surges on higher voltage lines, or from other sources. The temporary overvoltage capability can be determined from the TOV curve. The prior duty curve of this table is based upon absorption of rated energy immediately preceding application of the overvoltage.

### IEC (with Prior Duty) Temporary Overvoltage Capability



## Polymer Housed Arresters

### Polymer (EPDM & Silicon alloy) Housed Arresters (9L11XP & 9L12PP)

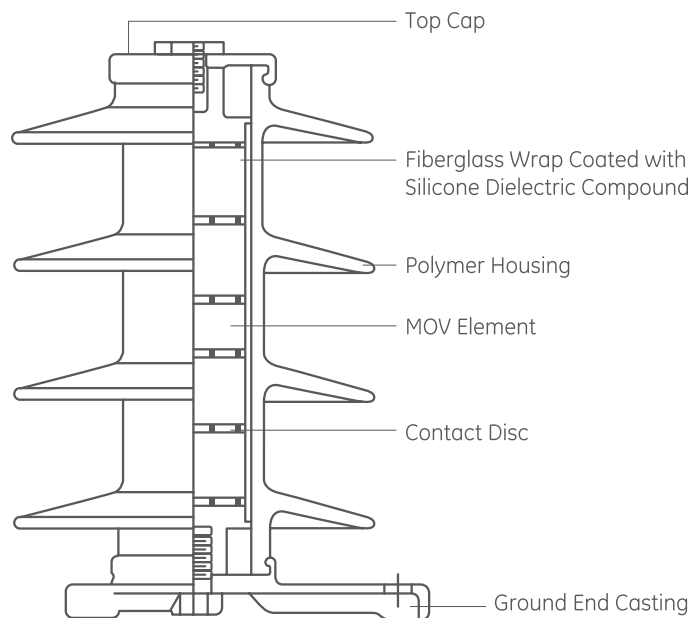
#### Construction

Polymer housings are comprised of a EPDM and Silicone alloy, resistant to rough handling and will not shatter in case of a failure. In comparison to equivalent porcelain-housed arresters, these polymer housed gapless arresters are typically half the weight. This makes transportation, handling and installation much easier.

The single-unit, high voltage designs provide improved contamination performance over multi-unit designs. Closer spacing—Smaller line end castings and smaller grading rings allow closer phase-to-phase spacing. MOV blocks are centered and restrained with tightly woven fiberglass filament strands impregnated with epoxy resin. Minimal Internal Atmosphere – Will not “Breathe” or leak which eliminates moisture ingress, a cause of arrester failure.

Default housing color is gray, brown is also available.

For non-catalog polymer arresters that require higher creepage or special application please consult your GE Vernova representative.



Section view of typical Polymer arrester

**Table 2: Polymer (EDPM/Silicone alloy) Overview**

PRODUCT TYPE	HOUSING MATERIAL	LINE DISCHARGE CLASS	VOLTAGE RATING RANGE (kV)	PRESSURE RELIEF (kA)	PHYSICAL STRENGTH (N.m)
9L12PP	Polymer	2	3 – 72	40	180*
9L11XP	Polymer	3	3 - 228	63	2,260*

NOTE: Physical Strength values for tripod base configuration

\*MPSL – Maximum Permissible Service Load

## 9L12PP (Class 2)

## 9L12PP Class 2 Protective Characteristics

Ur (kV)	Uc (kV)	MAXIMUM 0.5 $\mu$ s DISCHARGE VOLTAGE (kV) <sub>1</sub>	MAXIMUM SWITCHING SURGE PROTECTIVE LEVEL (kV)	MAXIMUM RESIDUAL VOLTAGE USING 8/20 CURRENT WAVE (kV)					
				1.5kA	3kA	5kA	10kA	20kA	40kA
3	2.55	8.6	6.4	6.8	7.2	7.5	8.1	9	10.1
6	5.1	17.1	12.7	13.6	14.4	15	16.2	17.9	20.2
9	7.65	25.8	19.1	20.5	21.6	22.6	24.4	27	30.4
10	8.4	28.4	21.1	22.6	23.8	24.9	26.9	29.8	33.5
12	10.2	34.1	25.3	27.1	28.6	29.9	32.3	35.8	40.3
15	12.7	42.9	31.8	34.1	36	37.6	40.6	44.9	50.6
18	15.3	51.6	38.3	40.9	43.2	45.2	48.8	54	60.9
21	17	56.9	42.2	45.1	47.7	49.9	53.8	59.6	67.1
24	19.5	68.3	50.6	54.2	57.2	59.9	64.6	71.5	80.6
27	22	77.4	57.4	61.4	64.9	67.9	73.2	81	91.3
30	24.4	85.3	63.3	67.7	71.5	74.8	80.7	89.3	101
36	29	102	76	81.3	85.9	89.8	96.9	107	121
39	31.5	108.4	80.4	86.1	90.9	95.1	102.6	113.6	127.9
45	36.5	125.1	92.8	99.3	104.9	109.8	118.4	131.1	147.6
48	39	136.6	101.3	108.4	114.5	119.8	129.2	143	161.1
54	42	147.9	109.7	117.4	125	129.7	139.9	154.9	174.5
60	48	165	122.4	131	138.3	144.7	156.1	172.8	195
72	57	199	147.7	158.1	166.9	174.6	188.4	209	235
90	70	250	185.7	198.7	209.8	219.5	236.8	262	295
96	76	261.7	194.1	207.7	219.4	229.5	247.6	274.1	308.8
108	88	296	219.5	234.9	248.1	259.6	280	310	349.2
120	98	327.7	243	260.1	274.7	287.4	310	343.2	386.6
132	106	375.2	278.3	297.8	314.5	329.1	355	393	443
144	115	392	290.9	311.3	328.7	343.9	371	411	463

(1) Maximum residual voltage for a 10kA impulse current wave which produces a voltage wave cresting in 0.5 $\mu$ s. This can be used for coordination where front-of-wave sparkover was formerly used.

(2) Based on a 500A surge of 45- $\mu$ s time to crest.

## 9L12PP Class 2 Physical Characteristics

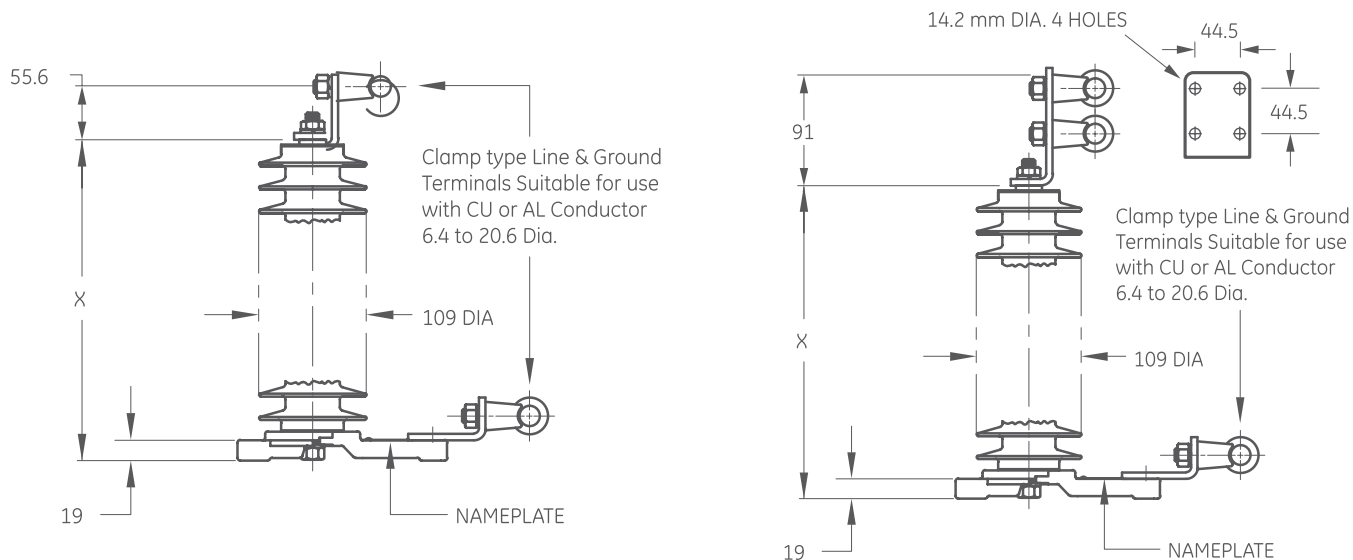
STANDARD ARRESTER CATALOG NUMBER	Ur (kV)	Uc (kV)	HEIGHT "X" DIMENSION (mm)	CREEPAGE DISTANCE (mm)	MINIMUM MOUNTING		NET WEIGHT (kg)	INSULATION WITHSTAND VALUES		
					PHASE TO PHASE (mm)	PHASE TO GROUND (mm)		LIGHTNING IMPULSE BIL 1.2/50 (kVcr)	SWITCHING IMPULSE (kVcr)	POWER FREQUENCY 1 MINUTE WET WITHSTAND (kVrms)
9L12PPA003S	3	2.55	173	391	112	84	2.8	100	60	40
9L12PPA0006S	6	5.1	173	391	117	81	2.8	100	60	40
9L12PPA0009S	9	7.65	173	391	119	84	2.8	100	60	40
9L12PPA010S	10	8.4	173	391	125	89	2.8	100	60	40
9L12PPA0012AS	12	10.2	173	391	125	89	2.8	100	60	40
9L12PPA015S	15	12.7	310	782	158	122	4.5	165	100	70
9L12PPA018S	18	15.3	310	782	168	132	4.5	165	100	70
9L12PPA021S	21	17	310	782	193	158	4.5	165	100	70
9L12PPA024AS	24	19.5	310	782	193	158	4.5	165	100	70
9L12PPA027S	27	22	447	1,173	244	208	6.1	230	140	105
9L12PPA030S	30	24.4	447	1,173	249	213	6.1	230	140	105
9L12PPA036AS	36	29	447	1,173	249	213	6.1	230	140	105
9L12PPA039S	39	31.5	584	1,565	325	290	7.7	310	180	140
9L12PPA045AS	45	36.5	584	1,565	325	290	7.7	310	180	140
9L12PPA048AS	48	39	584	1,565	325	290	7.7	310	180	140
9L12PPA054AS	54	42	721	1,956	401	366	8.8	390	230	180
9L12PPA060S	60	48	721	1,956	401	366	8.8	390	230	180
9L12PPA072AS	72	57	859	2,347	503	467	10.4	450	260	220

(1) Minimum clearances are based on arrester protective levels and should be increased when necessary to meet local requirements for spacing of energized equipment.

## 9L12PP (Class 2)

### 9L12PP Class 2 Polymer Base Mounting Information

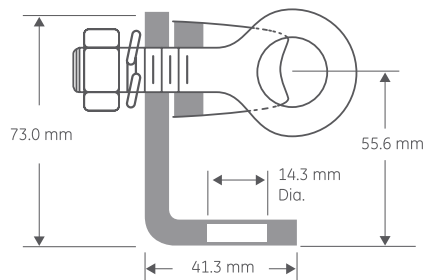
The end casting shown in Figure 1 is furnished with three slots suitable for use on either a 222.35 mm or 254 mm diameter bolt circle. Mounting hardware is not furnished with the arrester.



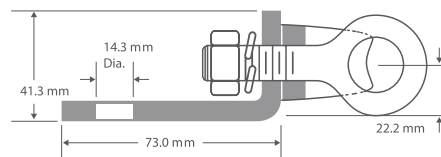
'X' distance can be found on the physical characteristics table on page 9.

### 9L12PP Terminals

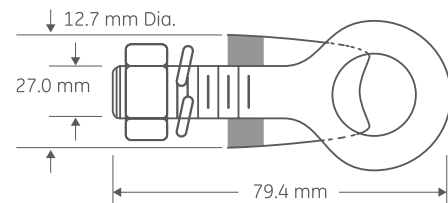
- Standard line and ground terminals will accommodate conductor sizes from 6 mm to 21mm diameter.
- The terminals are of hot dip galvanized malleable iron and compatible with either aluminum or copper.
- For other terminal options please consult your GE Vernova Representative.



**Figure 4**  
Standard Line Terminal  
(Small top only)



**Figure 5**  
Standard Ground Terminal



**Figure 6**  
Single Bucket Terminal Assembly used  
with all terminal combinations



## 9L11XP (Class 3)

### 9L11XP (EDPM/Silicon) Class 3 Protective Characteristics

Ur (kV)	Uc (kV)	MAXIMUM 0.5 $\mu$ S DISCHARGE VOLTAGE (kV) <sub>1</sub>	MAXIMUM SWITCHING SURGE PROTECTIVE LEVEL kV (2)	MAXIMUM RESIDUAL VOLTAGE USING AND 8/20 CURRENT WAVE-kV						INSULATION WITHSTAND VALUES		
				1.5kA	3kA	5kA	10kA	20kA	40kA	1.2/50 BIL (kVcr)	SWITCHING IMPULSE (kVcr)	POWER FREQUENCY/ MINUTE WET (kVrms)
3	2.55	8.4	6	6.4	6.7	7.1	7.6	8.4	9.6	120	88	57
6	5.1	16.7	11.9	12.8	13.5	14.1	15.2	16.8	19.1	120	88	57
9	7.65	25	17.8	19.2	20.2	21.1	22.7	25.1	28.3	120	88	57
10	8.4	27.8	19.8	21.4	22.5	23.5	25.3	28	31.8	120	88	57
12	10.2	33.3	23.7	25.6	26.9	28.1	30.3	33.5	38.1	161	113	74
15	12.7	41.7	29.7	32	33.7	35.2	37.9	42	47.6	161	113	74
18	15.3	50.1	35.6	38.4	40.4	42.3	45.5	50.4	57.2	161	113	74
21	17	56.3	40.1	43.2	45.5	47.6	51.2	56.7	64.4	241	163	109
24	19.5	63.9	45.5	49.1	51.6	54	58.1	64.3	73	241	163	109
27	22	72.9	51.9	56	58.9	61.6	66.3	73.4	83.3	241	163	109
30	24.4	80.4	57.2	61.7	64.9	67.9	73.1	80.9	91.9	241	163	109
36	29	95.9	68.3	73.6	77.4	81	87.2	96.5	109.6	241	163	109
39	31.5	104.2	74.2	80	84.1	88	94.7	104.8	119	321	213	145
45	36.5	120.9	86.1	92.8	97.6	102.1	109.9	121.7	138.1	321	213	145
48	39	128.7	91.6	96.8	103.9	108.7	117	129.5	147.1	321	213	145
54	42	144.4	102.8	110.9	116.6	122	131.3	145.3	165	401	264	182
60	48	163.5	116.4	125.5	132	138	146.6	164.5	186.8	401	264	182
72	57	191.8	136.6	147.3	154.9	162	174.4	193.1	219.2	450	295	200
90	70	241.8	172.1	185.6	195.2	204.2	219.8	243.3	276.3	639	415	295
96	76	257.4	183.2	197.6	207.8	217.4	234	259	294.1	639	415	295
108	84	288.9	205.6	221.8	233.2	244	262.6	290.7	330.1	700	450	320
108	88	288.9	205.6	221.8	233.2	244	262.6	290.7	330.1	700	450	320
120	98	326.9	241.3	251	263.9	276.1	297.2	329	373.6	660	428	306
132	106	352	252	270	284	298	317	353	404	660	428	306
144	115	386.1	285	296.5	311.7	326.1	351	388.6	441.2	817	530	385
168	131	445	330	343	363	380	409	446	503	1050	560	400
172	140	455	338	351	372	389	419	457	516	1050	560	400
180	144	476	354	367	389	407	438	478	539	1050	560	400
192	152	508	377	391	415	434	467	509	575	1050	560	400
228	180	604	448	465	493	516	556	607	664	1520	720	500

(1) Maximum residual voltage for a 10kA impulse current wave which produces a voltage wave cresting in 0.5 $\mu$ s. This can be used for coordination where front-of-wave sparkover was formerly used.

(2) Based on a 500A surge of 45- $\mu$ s time to crest through 88kV Uc, and 1,000A surge of 45 $\mu$ s time to crest of 98 kV Uc and higher ratings.

### 9L11XP Mounting Arrangements

Type 9L11XP arresters may be mounted vertically, horizontally or underhung, provided the cantilever moment is not excessive. Underhung mounting requires factory assembly of the base mounting hardware at the top of the arrester to

ensure proper shed orientation. For the correct underhung catalog number replace the third digit with 2 or 5 as shown in the 9L11XP Ordering System on the next page.

The 9L11XP arrester construction is non-rigid, and will exhibit an observable deflection when cantilever load is applied. This deflection is normal and will not affect

performance. The rated ultimate cantilever moment of the 9L11XP arrester with the tripod base is 2260 N.m. The maximum working moment for the 2.55-115 kV Uc is 1130 N.m. For 131 thru 180 kV Uc with the tripod base, the maximum working moment is 565 N.m. For the round cap base design, the maximum working moment is 339 N.m.

NOTE: 9L11XP arresters above 115kV Uc are not recommended for horizontal mounting.

9L11XP (Class 3)

9L11XP (EDPM/Silicon) Class 3 Physical Characteristics

STANDARD ARRESTER CATALOG NUMBER 4 HOLE NEMA	STANDARD ARRESTER CATALOG NUMBER SINGLE EYEBOLT	DUTY CYCLE (kV) rms	MCOV (kV) rms	HEIGHT (mm)	CREEPAGE (mm)	INSULATION WITHSTAND		WEIGHT kg	CANTILEVER STRENGTH			
						PHASE TO PHASE (mm)	PHASE TO GROUND (mm)		NOTE 1		NOTE 2	
									ft-lbs	Nm	Ft-lbs	Nm
9L11XPA003AS	9L11XPB003AS	3	2.55	251	498	229	114	5.9	761	3383	1521	15039
9L11XPA006AS	9L11XPB006AS	6	5.1	251	498	229	114	5.9	761	3383	1521	15039
9L11XPA009AS	9L11XPB009AS	9	7.65	297	765	229	114	6.8	669	2974	1337	13221
9L11XPA010AS	9L11XPB010AS	10	8.4	297	765	229	114	6.8	669	2974	1337	13221
9L11XPA012AS	9L11XPB012AS	12	10.2	297	765	229	117	6.8	669	2974	1337	13221
9L11XPA015AS	9L11XPB015AS	15	12.7	343	899	246	137	7.7	595	2645	1190	11759
9L11XPA018AS	9L11XPB018AS	18	15.3	343	899	269	155	7.7	595	2645	1190	11759
9L11XPA021AS	9L11XPB021AS	21	17	437	1029	284	170	10.0	489	2174	977	9664
9L11XPA024AS	9L11XPB024AS	24	19.5	437	1029	307	188	10.0	489	2174	977	9664
9L11XPA027AS	9L11XPB027AS	27	22	437	1029	328	208	10.0	489	2174	977	9664
9L11XPA030AS	9L11XPB030AS	30	24.4	437	1029	351	226	10.0	489	2174	977	9664
9L11XPA036AS	9L11XPB036AS	36	29	531	1293	391	262	12.2	414	1840	829	8182
9L11XPA039AS	9L11XPB039AS	39	31.5	531	1293	411	282	12.2	414	1840	829	8182
9L11XPA045AS	9L11XPB045AS	45	36.5	622	1562	455	320	14.0	360	1600	720	7114
9L11XPA048AS	9L11XPB048AS	48	39	622	1562	478	338	14.0	360	1600	720	7114
9L11XPA054AS	9L11XPB054AS	54	42	622	1562	521	378	14.0	360	1600	720	7114
9L11XPA060AS	9L11XPB060AS	60	48	716	1826	561	411	16.3	313	1391	636	6186
9L11XPA072AS	9L11XPB072AS	72	57	810	2093	645	488	18.6	284	1263	569	5613
9L11XPA090AS	9L11XPB090AS	90	70	1176	3124	775	602	26.7	202	898	403	3992
9L11XPA096AS	9L11XPB096AS	96	76	1176	3124	818	640	26.7	202	898	403	3992
9L11XPA108AS	9L11XPB108AS	108	84	1176	3124	904	716	26.7	202	898	403	3992
9L11SPA108AS	9L11SPA108AS	108	88	1176	3124	904	716	26.7	202	898	403	3992
9L11XPA120AS	9L11XPB120AS	120	98	1364	3655	1234	914	33.1	176	782	351	3478
9L11XPA132AS	9L11XPB132AS	132	106	1364	3655	1311	983	33.1	176	782	351	3478
9L11XPA144AS	9L11XPB144AS	144	115	1549	4186	1397	1059	37.2	156	693	311	3083
9L11XPA168AS	9L11XPB168AS	168	131	1842	4686	1567	1212	44.0	66	293	264	1304
9L11XPA172AS	9L11XPB172AS	172	140	2121	5481	1890	1537	54.4	58	258	230	1146
9L11XPA180AS	9L11XPB180AS	180	144	2121	5481	1938	1585	54.4	58	258	230	1146
9L11XPA192AS	9L11XPB192AS	192	152	2121	5481	2024	1671	54.4	58	258	230	1146
9L11XPA228AS	9L11XPB228AS	228	180	2400	6279	2278	1923	60.3	51	227	205	1008

\* Center line to center line is equivalent to phase-to-phase; center line to ground is equivalent to phase-to-ground. These are recommended minimum clearances only and as such are not intended to take precedence over existing construction codes or specifications.

<sup>1</sup> Cantilever Strength- Maximum Working Strength

<sup>2</sup> Cantilever strength- Rated Ultimate Cantilever Strength

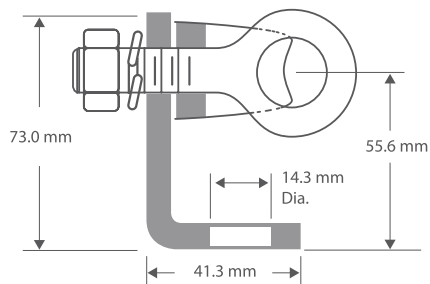
<sup>3</sup> Add 84 mm to "X" dimension for 4 Hole NEMA terminal and 73mm t o "X" dimension for Eyebolt designs for overall height

### 9L11XP Class 3 Terminals

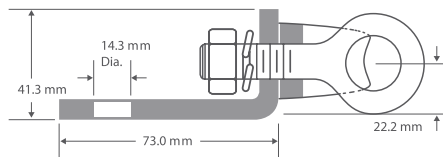
Standard line and ground terminals will accommodate conductor sizes from 6 mm to 21mm diameter.

The terminals are of hot dip galvanized malleable iron and compatible with either aluminum or copper.

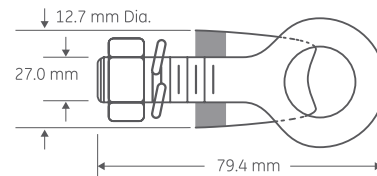
For other terminal options please contact your GE Vernova representative.



**Figure 3**  
Standard Line Terminal  
(Small top only)

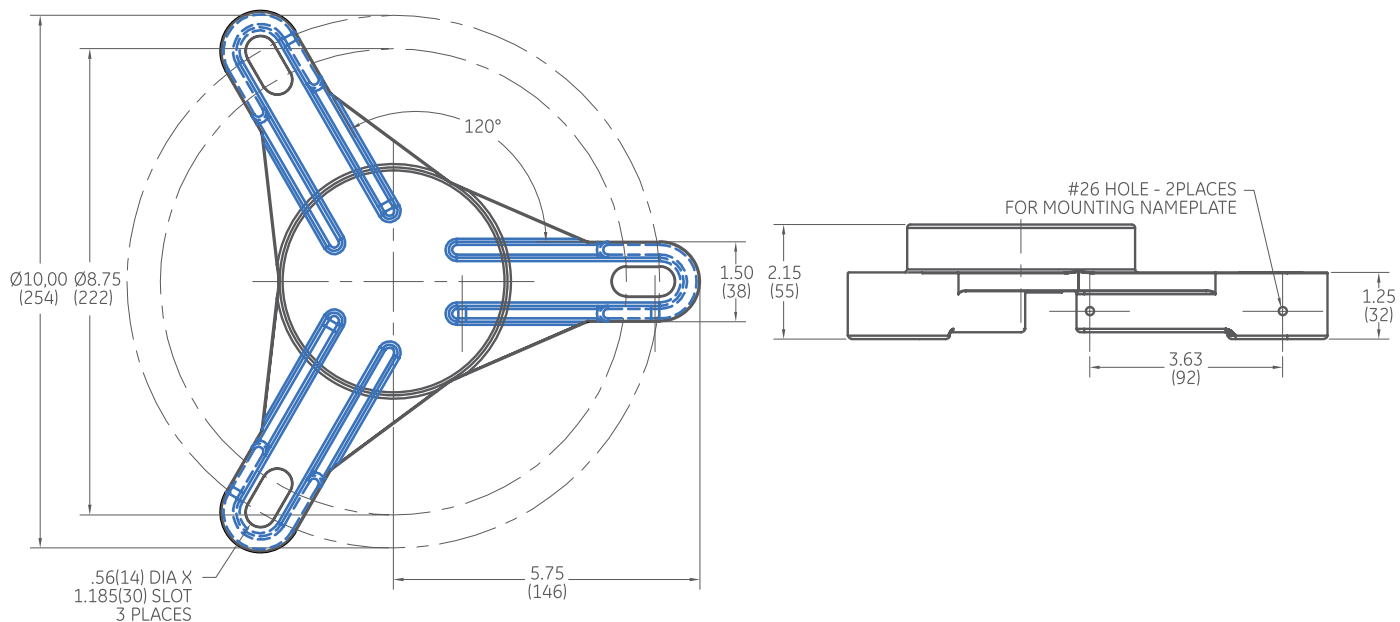


**Figure 4**  
Standard Ground Terminal



**Figure 5**  
Single Bucket Terminal Assembly used with all terminal combinations

### Mounting Base



Dimensions are in inches (millimeters)

# Silicone Class 3

## Silicone Housed Arresters (9L11CMA, CHA, CVA: Class 3 & Class 4)

### Construction

- Hollow Core Design
- Silicone Rubber Housing
- Same proven sealing system as used in our porcelain 9L11Z designs
- High mechanical strength
- High creepage distance designs available
- Same high quality MOV technology as other GE Vernova arresters
- Polymer housing is colored gray

For non-catalog polymer arresters that require higher creepage or special application please consult your GE Vernova representative.

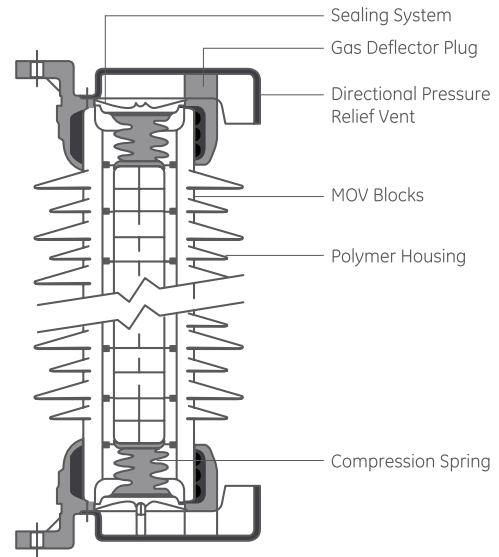


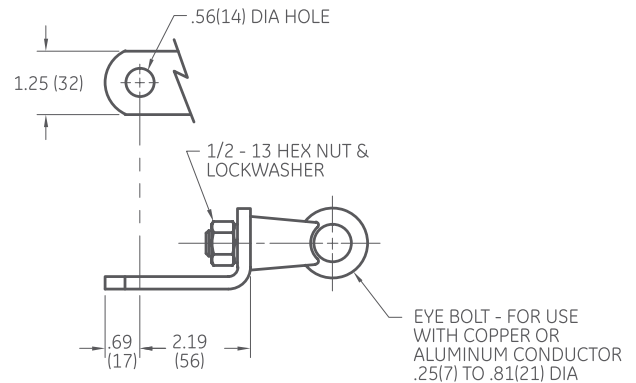
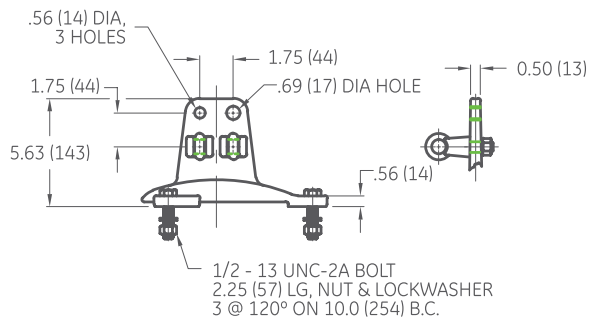
Table 5: Silicone Overview

PRODUCT TYPE	HOUSING MATERIAL	LINE DISCHARGE CLASS	VOLTAGE RATING RANGE (kV)	PRESSURE RELIEF (kA)	PHYSICAL STRENGTH (N.m)
9L11CMA, CHA, CVA S3	Silicone	3	24-420	63	8,000*
9L11CMA, CHA, CVA S4	Silicone	4	24-420	63	8,000*

\* MPSSL – Maximum Permissible Service Load

## 9L11C Silicone Arrester Hardware

### Suspension Cap



Material: steel, hot dipped galvanized

### Notes:

1. Dimensions subject to ±3% tolerance
2. Dimensions in parenthesis are in millimeters
3. Clamp type terminals suitable for copper or aluminum conductors 7 to 21 mm
4. Larger clamp type terminals for 11 to 25 mm are available

Arrester base has three 14mm holes, 120° apart on 254 mm bolt circle.

## 9L11C Class 3 Physical Characteristics

CATALOG NUMBER	Um	Ur	Uc	POLLUTION LEVEL	NOMINAL CREEP (mm)	WEIGHT (kg)	TOTAL HEIGHT mm	STACK HEIGHT WITHOUT CAP (mm)	LIGHTNING IMPULSE* (kV)	SWITCHING IMPULSE* (kV)	60Hz PF, 1 MIN WET
9L11CMA027S3	36	27	21.6	ALL	2130	48	967	824	367	266	189
9L11CMA030S3	36	30	24	ALL	2130	48	967	824	367	266	189
9L11CMA033S3	36	33	26.4	ALL	2130	49	967	824	367	266	189
9L11CMA036S3	36	36	28.8	ALL	2130	49	967	824	367	266	189
9L11CMA039S3	36	39	31.2	ALL	2130	50	967	824	367	266	189
9L11CMA042S3	52	42	33.6	ALL	2130	50	967	824	367	266	189
9L11CMA048S3	52	48	38.4	ALL	2130	51	967	824	367	266	189
9L11CMA051S3	52	51	40.8	ALL	2130	51	967	824	367	266	189
9L11CMA054S3	52	54	43.2	ALL	2130	51	967	824	367	266	189
9L11CMA060S3	52	60	48	ALL	2130	52	967	824	367	266	189
9L11CMA054S3	72	54	43.2	Medium & heavy	2130	51	967	824	367	266	189
9L11CVA054S3	72	54	43.2	Very heavy	2880	54	1127	984	480	348	247
9L11CMA060S3	72	60	48	Medium & heavy	2130	52	967	824	367	266	189
9L11CVA060S3	72	60	48	Very heavy	2880	55	1127	984	480	348	247
9L11CMA066S3	72	66	52.8	Medium & heavy	2130	53	967	824	367	266	189
9L11CVA066S3	72	66	52.8	Very heavy	2880	56	1127	984	480	348	247
9L11CMA072S3	72	72	57.6	Medium & heavy	2130	54	967	824	367	266	189
9L11CVA072S3	72	72	57.6	Very heavy	2880	56	1127	984	480	348	247
9L11CMA075S3	72	75	60	Medium & heavy	2130	54	967	824	367	266	189
9L11CVA075S3	72	75	60	Very heavy	2880	57	1127	984	480	348	247
9L11CMA078S3	72	78	62.4	Medium & heavy	2130	55	967	824	367	266	189
9L11CVA078S3	72	78	62.4	Very heavy	2880	57	1127	984	480	348	247
9L11CMA081S3	72	81	64.8	Medium & heavy	2130	55	967	824	367	266	189
9L11CVA081S3	72	81	64.8	Very heavy	2880	58	1127	984	480	348	247
9L11CVA084S3	72	84	67.2	ALL	2880	58	1127	984	480	348	247
9L11CMA084S3	100	84	67.2	Medium & heavy	2880	58	1127	984	480	348	247
9L11CVA084S3	100	84	67.2	Very heavy	3260	62	1323	1180	585	424	301
9L11CMA090S3	100	90	72	Medium & heavy	2880	59	1127	984	480	348	247
9L11CVA090S3	100	90	72	Very heavy	3620	63	1323	1180	585	424	301
9L11CMA096S3	100	96	76.8	Medium & heavy	2880	60	1127	984	480	348	247
9L11CVA096S3	100	96	76.8	Very heavy	3620	64	1323	1180	585	424	301
9L11CMA090S3	123	90	72	Medium	2880	59	1127	984	480	348	247
9L11CHA090S3	123	90	72	Heavy	3620	63	1323	1180	585	424	301
9L11CVA090S3	123	90	72	Very heavy	4370	67	1493	1350	690	500	355
9L11CMA096S3	123	96	76.8	Medium	2880	60	1127	984	480	348	247
9L11CHA096S3	123	96	76.8	Heavy	3620	64	1323	1180	585	424	301
9L11CVA096S3	123	96	76.8	Very heavy	4370	68	1493	1350	690	500	355
9L11CMA108S3	123	108	86.4	Medium & heavy	3620	65	1323	1180	585	424	301
9L11CVA108S3	123	108	86.4	Very heavy	4370	70	1493	1350	690	500	355
9L11CMA120S3	123	120	96	Medium & heavy	3620	67	1323	1180	585	424	301
9L11CVA120S3	123	120	96	Very heavy	4370	71	1493	1350	690	500	355

## Polymer Class 3

### 9L11C Class 3 Physical Characteristics

CATALOG NUMBER	Um	Ur	Uc	POLLUTION LEVEL	NOMINAL CREEP (mm)	WEIGHT (kg)	TOTAL HEIGHT mm	STACK HEIGHT WITHOUT CAP (mm)	LIGHTNING IMPULSE* (kV)	SWITCHING IMPULSE* (kV)	60Hz PF, 1 MIN WET
9L11CVA132S3	123	132	100.8	ALL	4370	73	1493	1350	690	500	355
9L11CMA138S3	123	138	110.4	ALL	4370	74	1493	1350	690	500	355
9L11CMA108S3	145	108	86.4	Medium	3620	65	1323	1180	585	424	301
9L11CHA108S3	145	108	86.4	Heavy	4370	70	1493	1350	690	500	355
9L11CVA108S3	145	108	86.4	Very heavy	5010	101	1951	1808	847	614	436
9L11CMA120S3	145	120	96	Medium	3620	67	1323	1180	585	424	301
9L11CHA120S3	145	120	96	Heavy	4370	71	1493	1350	690	500	355
9L11CVA120S3	145	120	96	Very heavy	5010	102	1951	1808	847	614	436
9L11CMA132S3	145	132	105.6	Medium & heavy	4370	73	1493	1350	690	500	355
9L11CVA132S3	145	132	105.6	Very heavy	5010	104	1951	1808	847	614	436
9L11CMA138S3	145	138	110.4	Medium & heavy	4370	74	1493	1350	690	500	355
9L11CVA138S3	145	138	110.4	Very heavy	5010	105	1951	1808	847	614	436
9L11CMA144S3	145	144	115.2	Medium & heavy	4370	74	1493	1350	690	500	355
9L11CVA144S3	145	144	115.2	Very heavy	5010	106	1951	1808	847	614	436
9L11CMA132S3	170	132	105.6	Medium & heavy	4370	73	1493	1350	690	500	355
9L11CVA132S3	170	132	105.6	Very heavy	5760	106	2111	1968	960	696	494
9L11CMA144S3	170	144	115.2	Medium & heavy	4370	74	1493	1350	690	500	355
9L11CVA144S3	170	144	115.2	Very heavy	5760	108	2111	1968	960	696	494
9L11CMA162S3	170	162	129.6	Medium & heavy	5010	108	1951	1808	847	614	436
9L11CVA162S3	170	162	129.6	Very heavy	5760	110	2111	1968	960	696	494
9L11CMA168S3	170	168	134.4	Medium & heavy	5010	109	1951	1808	847	614	436
9L11CVA168S3	170	168	134.4	Very heavy	5760	111	2111	1968	960	696	494
9L11CMA180S3	245	180	144	Medium	5010	118	1951	1808	847	614	436
9L11CHA180S3	245	180	144	Heavy	6500	125	2307	2164	1065	772	548
9L11CVA180S3	245	180	144	Very heavy	7990	133	2673	2530	1275	924	656
9L11CMA192S3	245	192	153.6	Medium	5760	122	2111	1968	960	696	494
9L11CHA192S3	245	192	153.6	Heavy	6500	126	2307	2164	1065	772	548
9L11CVA192S3	245	192	153.6	Very heavy	7990	135	2673	2530	1275	924	656
9L11CMA198S3	245	198	158.4	Medium	5760	123	2111	1968	960	696	494
9L11CHA198S3	245	198	158.4	Heavy	6500	127	2307	2164	1065	772	548
9L11CVA198S3	245	198	158.4	Very heavy	7990	135	2673	2530	1275	924	656
9L11CMA216S3	245	216	172.8	Medium & heavy	6500	133	2307	2164	1065	772	548
9L11CVA216S3	245	216	172.8	Very heavy	7990	141	2673	2530	1275	924	656
9L11CMA228S3	245	228	182.4	Medium & heavy	6500	131	2307	2164	1065	772	548
9L11CVA228S3	245	228	182.4	Very heavy	7990	139	2673	2530	1275	924	656
9L11CMA216S3	300	216	172.8	Medium	6500	133	2307	2164	1065	772	548
9L11CHA216S3	300	216	172.8	Heavy	7990	141	2673	2530	1275	924	656
9L11CVA216S3	300	216	172.8	Very heavy	9380	175	3291	3148	1545	1120	795
9L11CMA228S3	300	228	182.4	Medium	6500	131	2307	2164	1065	772	548
9L11CHA228S3	300	228	182.4	Heavy	7990	139	2673	2530	1275	924	656
9L11CVA228S3	300	228	182.4	Very heavy	9380	173	3291	3148	1545	1120	795

## 9L11C Class 3 Physical Characteristics (con't)

CATALOG NUMBER	Um	Ur	Uc	POLLUTION LEVEL	NOMINAL CREEP (mm)	WEIGHT (kg)	TOTAL HEIGHT mm	STACK HEIGHT WITHOUT CAP (mm)	LIGHTNING IMPULSE* (kV)	SWITCHING IMPULSE* (kV)	60Hz PF, 1 MIN WET
9L11CMA240S3	300	240	192	Medium	7240	137	2503	2360	1170	848	602
9L11CHA240S3	300	240	192	Heavy	7990	141	2673	2530	1275	924	656
9L11CVA240S3	300	240	192	Very heavy	9380	175	3291	3148	1545	1120	795
9L11CMA258S3	300	258	206.4	Medium & heavy	7990	147	2673	2530	1275	924	656
9L11CVA258S3	300	258	206.4	Very heavy	9380	180	3291	3148	1545	1120	795
9L11CMA264S3	300	264	211.2	Medium & heavy	7990	148	2673	2530	1275	924	656
9L11CVA264S3	300	264	211.2	Very heavy	9380	181	3291	3148	1545	1120	795
9L11CMA258S3	362	258	206.4	Medium	7990	147	2673	2530	1275	924	656
9L11CHA258S3	362	258	206.4	Heavy	9380	180	3291	3148	1545	1120	795
9L11CVA258S3	362	258	206.4	Very heavy	11610	193	3853	3710	1860	1348	957
9L11CMA264S3	362	264	211.2	Medium	7990	148	2673	2530	1275	924	656
9L11CHA264S3	362	264	211.2	Heavy	9380	181	3291	3148	1545	1120	795
9L11CVA264S3	362	264	211.2	Very heavy	11610	193	3853	3710	1860	1348	957
9L11CMA276S3	362	276	220.8	Medium	7990	149	2673	2530	1275	924	656
9L11CHA276S3	362	276	220.8	Heavy	9380	183	3291	3148	1545	1120	795
9L11CVA276S3	362	276	220.8	Very heavy	11610	195	3853	3710	1860	1348	957
9L11CMA288S3	362	288	230.4	Medium	8740	155	2843	2700	1380	1000	710
9L11CHA288S3	362	288	230.4	Heavy	9380	184	3291	3148	1545	1120	795
9L11CVA288S3	362	288	230.4	Very heavy	11610	197	3853	3710	1860	1348	957
9L11CMA312S3	420	312	249.6	Medium	9380	202	3291	3148	1545	1120	795
9L11CHA312S3	420	312	249.6	Heavy	10860	210	3683	3540	1755	1272	903
9L11CVA312S3	420	312	249.6	Very heavy	13110	223	4193	4050	2070	1500	1065
9L11CMA330S3	420	330	264	Medium	9380	204	3291	3148	1545	1120	795
9L11CHA330S3	420	330	264	Heavy	10860	213	3683	3540	1755	1272	903
9L11CVA330S3	420	330	264	Very heavy	13110	225	4193	4050	2070	1500	1065
9L11CMA336S3	420	336	268.8	Medium	10120	210	3487	3344	1650	1196	849
9L11CHA336S3	420	336	268.8	Heavy	10860	213	3683	3540	1755	1272	903
9L11CVA336S3	420	336	268.8	Very heavy	13110	226	4193	4050	2070	1500	1065
9L11CMA360S3	420	360	288	Medium & heavy	10860	202	3683	3540	1755	1272	903
9L11CVA360S3	420	360	288	Very heavy	13110	215	4193	4050	2070	1500	1065
9L11CMA372S3	420	372	297.6	Medium & heavy	10860	204	3683	3540	1755	1272	903
9L11CVA372S3	420	372	297.6	Very heavy	13110	217	4193	4050	2070	1500	1065
9L11CMA378S3	420	378	302.4	Medium & heavy	10860	205	3683	3540	1755	1272	903
9L11CVA378S3	420	378	302.4	Very heavy	13110	217	4193	4050	2070	1500	1065
9L11CHA390S3	420	390	312	Medium & heavy	11610	211	3853	3710	1860	1348	957
9L11CVA390S3	420	390	312	Very heavy	13110	219	4193	4050	2070	1500	1065
9L11CMA396S3	420	396	316.8	Medium & heavy	11610	211	3853	3710	1860	1348	957
9L11CVA396S3	420	396	316.8	Very heavy	13110	220	4193	4050	2070	1500	1065
9L11CMA420S3	420	420	336	Medium & heavy	12360	219	4023	3880	1965	1424	1011
9L11CVA420S3	420	420	336	Very heavy	13110	223	4193	4050	2070	1500	1065

\* Linear insulation withstand for comparison based on sum of units

## Polymer Class 3

### 9L11C Class 3 Protective Characteristics

Ur	Uc	PREVIOUS DUTY TOV (kV)			SWITCHING IMPULSE RESIDUAL VOLTAGE (kV)				MAXIMUM 8/20 RESIDUAL VOLTAGE AT INDICATED CURRENT (kV)					
		1 S	10 S	100 S	0.25 kA	0.50 kA	1.0 kA	2.0 kA	1.5 kA	2.5 kA	5 kA	10 kA	20 kA	40 kA
27	21.6	29	27	26	51	52	54	57	56	58	61	65	71	81
30	24	33	31	29	56	58	60	63	62	65	68	72	78	89
33	26.4	36	34	32	62	63	66	69	68	71	74	79	86	98
36	28.8	39	37	34	68	69	72	75	74	77	81	87	94	107
39	31.2	42	40	37	73	75	78	81	80	84	88	94	102	116
42	33.6	46	43	40	79	81	84	88	87	90	95	101	110	125
48	38.4	52	49	46	90	92	95	100	99	103	108	115	125	142
51	40.8	55	52	49	95	97	101	106	105	109	114	122	132	151
54	43.2	59	55	52	102	104	108	113	112	116	122	130	141	161
60	48	65	61	57	112	115	119	125	124	129	135	144	156	178
66	52.8	72	67	63	123	126	131	137	136	141	148	158	171	195
72	57.6	78	73	69	135	138	143	150	148	154	162	173	188	214
75	60	82	76	72	140	143	149	156	154	161	168	180	195	222
78	62.4	85	79	75	146	149	155	162	160	167	175	187	203	231
81	64.8	88	82	78	151	154	161	168	166	173	181	194	210	240
84	67.2	91	86	80	157	160	167	174	172	179	188	201	218	248
90	72	98	92	86	168	172	179	187	185	193	202	216	234	267
96	76.8	104	98	92	179	183	190	199	197	205	215	230	249	284
108	86.4	118	110	103	202	206	214	225	222	231	242	259	280	320
120	96	131	122	115	223	228	238	249	246	256	268	287	311	354
132	100.8	144	134	126	246	251	262	274	271	282	295	316	342	390
138	110.4	150	140	132	257	262	273	286	283	294	308	330	357	407
144	115.2	157	147	138	269	274	285	299	295	308	322	345	373	426
162	129.6	176	165	155	302	308	321	336	332	346	362	388	420	479
168	134.4	183	171	161	313	319	333	348	344	358	375	402	435	496
180	144	196	183	172	335	342	357	373	369	384	402	431	466	532
192	153.6	209	195	184	358	365	380	398	394	410	429	460	498	568
198	158.4	215	202	190	369	376	392	411	406	422	442	474	513	585
216	172.8	235	220	207	402	410	428	448	443	461	482	517	559	638
228	182.4	248	232	218	425	433	451	473	467	486	509	546	591	674
240	192	261	244	230	446	456	475	497	491	511	535	574	621	708
258	206.4	281	263	247	480	490	510	534	528	550	576	617	667	761
264	211.2	287	269	253	492	502	523	547	541	563	590	632	684	780
258	206.4	281	263	247	480	490	510	534	528	550	576	617	667	761
264	211.2	287	269	253	492	502	523	547	541	563	590	632	684	780
276	220.8	300	281	264	513	524	546	571	565	588	616	660	714	814
288	230.4	313	293	276	536	547	570	596	590	614	643	689	745	850
312	249.6	339	318	299	580	592	617	646	638	664	696	746	807	920
330	264	359	336	316	614	626	652	683	675	703	736	789	853	973



## 9L11C Class 3 Protective Characteristics (con't)

Ur	Uc	PREVIOUS DUTY TOV (kV)			SWITCHING IMPULSE RESIDUAL VOLTAGE (kV)				MAXIMUM 8/20 RESIDUAL VOLTAGE AT INDICATED CURRENT (kV)					
		1 S	10 S	100 S	0.25 kA	0.50 kA	1.0 kA	2.0 kA	1.5 kA	2.5 kA	5 kA	10 kA	20 kA	40 kA
336	268.8	366	342	322	625	638	665	696	688	716	750	804	870	992
360	288	392	366	345	669	683	712	745	737	767	803	861	931	1062
372	297.6	405	379	356	692	706	736	770	761	793	830	890	963	1098
378	302.4	411	385	362	703	717	747	782	773	805	843	904	978	1115
390	312	424	397	374	725	740	771	808	798	831	870	933	1009	1151
396	316.8	431	403	379	736	751	783	820	810	843	883	947	1024	1168
420	336	457	428	402	781	797	831	870	860	895	937	1005	1087	1240

# Polymer Class 4

## 9L11C Class 4 Physical Characteristics

CATALOG NUMBER	Um	Ur	Uc	POLLUTION LEVEL	NOMINAL CREEP (mm)	WEIGHT (kg)	TOTAL HEIGHT mm	STACK HEIGHT WITHOUT CAP (mm)	LIGHTNING IMPULSE* (kV)	SWITCHING IMPULSE* (kV)	60Hz PF, IN. WET (kV)
9L11CVA027S4	36	27	21.6	ALL	2130	50	967	824	367	266	189
9L11CVA030S4	36	30	24	ALL	2130	51	967	824	367	266	189
9L11CVA033S4	36	33	26.4	ALL	2130	51	967	824	367	266	189
9L11CVA036S4	36	36	28.8	ALL	2130	52	967	824	367	266	189
9L11CVA039S4	36	39	31.2	ALL	2130	52	967	824	367	266	189
9L11CVA042S4	52	42	33.6	ALL	2130	53	967	824	367	266	189
9L11CVA048S4	52	48	38.4	ALL	2130	54	967	824	367	266	189
9L11CVA051S4	52	51	40.8	ALL	2130	55	967	824	367	266	189
9L11CMA054S4	52	54	43.2	ALL	2130	55	967	824	367	266	189
9L11CMA060S4	52	60	48	ALL	2130	56	967	824	367	266	189
9L11CMA054S4	72	54	43.2	Medium & heavy	2130	55	967	824	367	266	189
9L11CVA054S4	72	54	43.2	Very heavy	2880	58	1127	984	480	348	247
9L11CMA060S4	72	60	48	Medium & heavy	2130	56	967	824	367	266	189
9L11CVA060S4	72	60	48	Very heavy	2880	59	1127	984	480	348	247
9L11CHA066S4	72	66	52.8	Medium & heavy	2130	58	967	824	367	266	189
9L11CVA066S4	72	66	52.8	Very heavy	2880	60	1127	984	480	348	247
9L11CHA072S4	72	72	57.6	Medium & heavy	2130	59	967	824	367	266	189
9L11CVA072S4	72	72	57.6	Very heavy	2880	62	1127	984	480	348	247
9L11CHA075S4	72	75	60	Medium & heavy	2130	60	967	824	367	266	189
9L11CVA075S4	72	75	60	Very heavy	2880	63	1127	984	480	348	247
9L11CHA078S4	72	78	62.4	Medium & heavy	2130	60	967	824	367	266	189
9L11CVA078S4	72	78	62.4	Very heavy	2880	63	1127	984	480	348	247
9L11CHA081S4	72	81	64.8	Medium & heavy	2130	61	967	824	367	266	189
9L11CVA081S4	72	81	64.8	Very heavy	2880	64	1127	984	480	348	247
9L11CVA084S4	72	84	67.2	ALL	2880	64	1127	984	480	348	247
9L11CMA084S4	100	84	67.2	Medium & heavy	2880	64	1127	984	480	348	247
9L11CVA084S4	100	84	67.2	Very heavy	3260	68	1323	1180	585	424	301
9L11CMA090S4	100	90	72	Medium & heavy	2880	65	1127	984	480	348	247
9L11CHA090S4	100	90	72	Very heavy	3620	69	1323	1180	585	424	301
9L11CHA096S4	100	96	76.8	Medium & heavy	2880	66	1127	984	480	348	247
9L11CVA096S4	100	96	76.8	Very heavy	3620	70	1323	1180	585	424	301
9L11CMA090S4	123	90	72	Medium	2880	65	1127	984	480	348	247
9L11CHA090S4	123	90	72	Heavy	3620	69	1323	1180	585	424	301
9L11CVA090S4	123	90	72	Very heavy	4370	73	1493	1350	690	500	355
9L11CMA096S4	123	96	76.8	Medium	2880	66	1127	984	480	348	247
9L11CHA096S4	123	96	76.8	Heavy	3620	70	1323	1180	585	424	301
9L11CVA096S4	123	96	76.8	Very heavy	4370	75	1493	1350	690	500	355
9L11CHA108S4	123	108	86.4	Medium & heavy	3620	73	1323	1180	585	424	301
9L11CVA108S4	123	108	86.4	Very heavy	4370	77	1493	1350	690	500	355
9L11CHA120S4	123	120	96	Medium & heavy	3620	75	1323	1180	585	424	301
9L11CVA120S4	123	120	96	Very heavy	4370	80	1493	1350	690	500	355

## 9L11C Class 4 Physical Characteristics (con't)

CATALOG NUMBER	Um	Ur	Uc	POLLUTION LEVEL	NOMINAL CREEP (mm)	WEIGHT (kg)	TOTAL HEIGHT mm	STACK HEIGHT WITHOUT CAP (mm)	LIGHTNING IMPULSE* (kV)	SWITCHING IMPULSE* (kV)	60Hz PF, IN. WET (kV)
9L11CVA132S4	123	132	100.8	ALL	4370	82	1493	1350	690	500	355
9L11CVA138S4	123	138	110.4	ALL	4370	84	1493	1350	690	500	355
9L11CMA108S4	145	108	86.4	Medium	3620	73	1323	1180	585	424	301
9L11CHA108S4	145	108	86.4	Heavy	4370	77	1493	1350	690	500	355
9L11CVA108S4	145	108	86.4	Very heavy	5010	108	1951	1808	847	614	436
9L11CMA120S4	145	120	96	Medium	3620	75	1323	1180	585	424	301
9L11CHA120S4	145	120	96	Heavy	4370	80	1493	1350	690	500	355
9L11CVA120S4	145	120	96	Very heavy	5010	111	1951	1808	847	614	436
9L11CMA132S4	145	132	105.6	Medium & heavy	4370	82	1493	1350	690	500	355
9L11CVA132S4	145	132	105.6	Very heavy	5010	113	1951	1808	847	614	436
9L11CMA138S4	145	138	110.4	Medium & heavy	4370	84	1493	1350	690	500	355
9L11CVA138S4	145	138	110.4	Very heavy	5010	114	1951	1808	847	614	436
9L11CMA144S4	145	144	115.2	Medium & heavy	4370	115	1951	1808	847	614	436
9L11CVA144S4	145	144	115.2	Very heavy	5010	115	1951	1808	847	614	436
9L11CMA132S4	170	132	105.6	Medium & heavy	4370	82	1493	1350	690	500	355
9L11CVA132S4	170	132	105.6	Very heavy	5760	116	2111	1968	960	696	494
9L11CMA144S4	170	144	115.2	Medium & heavy	4370	85	1493	1350	690	500	355
9L11CVA144S4	170	144	115.2	Very heavy	5760	118	2111	1968	960	696	494
9L11CHA162S4	170	162	129.6	Medium & heavy	5010	119	1951	1808	847	614	436
9L11CVA162S4	170	162	129.6	Very heavy	5760	122	2111	1968	960	696	494
9L11CHA168S4	170	168	134.4	Medium & heavy	5010	121	1951	1808	847	614	436
9L11CVA168S4	170	168	134.4	Very heavy	5760	123	2111	1968	960	696	494
9L11CMA180S4	245	180	144	Medium	5010	131	1951	1808	847	614	436
9L11CHA180S4	245	180	144	Heavy	6500	138	2307	2164	1065	772	548
9L11CVA180S4	245	180	144	Very heavy	7990	146	2673	2530	1275	924	656
9L11CMA192S4	245	192	153.6	Medium	5760	136	2111	1968	960	696	494
9L11CHA192S4	245	192	153.6	Heavy	6500	140	2307	2164	1065	772	548
9L11CVA192S4	245	192	153.6	Very heavy	7990	148	2673	2530	1275	924	656
9L11CMA198S4	245	198	158.4	Medium	5760	137	2111	1968	960	696	494
9L11CHA198S4	245	198	158.4	Heavy	6500	141	2307	2164	1065	772	548
9L11CVA198S4	245	198	158.4	Very heavy	7990	149	2673	2530	1275	924	656
9L11CHA216S4	245	216	172.8	Medium & heavy	6500	148	2307	2164	1065	772	548
9L11CVA216S4	245	216	172.8	Very heavy	7990	156	2673	2530	1275	924	656
9L11CHA228S4	245	228	182.4	Medium & heavy	6500	147	2307	2164	1065	772	548
9L11CHA228S4	245	228	182.4	Very heavy	7990	156	2673	2530	1275	924	656
9L11CMA216S4	300	216	172.8	Medium	6500	148	2307	2164	1065	772	548
9L11CHA216S4	300	216	172.8	Heavy	7990	156	2673	2530	1275	924	656
9L11CVA216S4	300	216	172.8	Very heavy	9380	190	3291	3148	1545	1120	795
9L11CMA228S4	300	228	182.4	Medium	6500	147	2307	2164	1065	772	548
9L11CHA228S4	300	228	182.4	Heavy	7990	156	2673	2530	1275	924	656
9L11CVA228S4	300	228	182.4	Very heavy	9380	189	3291	3148	1545	1120	795

# Polymer Class 4

## 9L11C Class 4 Physical Characteristics

CATALOG NUMBER	Um	Ur	Uc	POLLUTION LEVEL	NOMINAL CREEP (mm)	WEIGHT (kg)	TOTAL HEIGHT mm	STACK HEIGHT WITHOUT CAP (mm)	LIGHTNING IMPULSE* (kV)	SWITCHING IMPULSE* (kV)	60Hz PF, IN. WET (kV)
9L11CMA240S4	300	240	192	Medium	7240	154	2503	2360	1170	848	602
9L11CHA240S4	300	240	192	Heavy	7990	158	2673	2530	1275	924	656
9L11CVA240S4	300	240	192	Very heavy	9380	191	3291	3148	1545	1120	795
9L11CHA258S4	300	258	206.4	Medium & heavy	7990	165	2673	2530	1275	924	656
9L11CHA258S4	300	258	206.4	Very heavy	9380	198	3291	3148	1545	1120	795
9L11CA264S4	300	264	211.2	Medium & heavy	7990	166	2673	2530	1275	924	656
9L11CVA264S4	300	264	211.2	Very heavy	9380	200	3291	3148	1545	1120	795
9L11CMA258S4	362	258	206.4	Medium	7990	165	2673	2530	1275	924	656
9L11CHA258S4	362	258	206.4	Heavy	9380	198	3291	3148	1545	1120	795
9L11CVA258S4	362	258	206.4	Very heavy	11610	211	3853	3710	1860	1348	957
9L11CMA264S4	362	264	211.2	Medium	7990	166	2673	2530	1275	924	656
9L11CHA264S4	362	264	211.2	Heavy	9380	200	3291	3148	1545	1120	795
9L11CVA264S4	362	264	211.2	Very heavy	11610	212	3853	3710	1860	1348	957
9L11CMA276S4	362	276	220.8	Medium	7990	168	2673	2530	1275	924	656
9L11CHA276S4	362	276	220.8	Heavy	9380	202	3291	3148	1545	1120	795
9L11CVA276S4	362	276	220.8	Very heavy	11610	215	3853	3710	1860	1348	957
9L11CMA288S4	362	288	230.4	Medium	8740	176	2843	2700	1380	1000	710
9L11CHA288S4	362	288	230.4	Heavy	9380	205	3291	3148	1545	1120	795
9L11CVA288S4	362	288	230.4	Very heavy	11610	217	3853	3710	1860	1348	957
9L11CMA312S4	420	312	249.6	Medium	9380	224	3291	3148	1545	1120	795
9L11CHA312S4	420	312	249.6	Heavy	10860	232	3683	3540	1755	1272	903
9L11CVA312S4	420	312	249.6	Very heavy	13110	245	4193	4050	2070	1500	1065
9L11CMA330S4	420	330	264	Medium	9380	228	3291	3148	1545	1120	795
9L11CHA330S4	420	330	264	Heavy	10860	236	3683	3540	1755	1272	903
9L11CVA330S4	420	330	264	Very heavy	13110	249	4193	4050	2070	1500	1065
9L11CMA336S4	420	336	268.8	Medium	10120	233	3487	3344	1650	1196	849
9L11CHA336S4	420	336	268.8	Heavy	10860	237	3683	3540	1755	1272	903
9L11CVA336S4	420	336	268.8	Very heavy	13110	250	4193	4050	2070	1500	1065
9L11CHA360S4	420	360	288	Medium & heavy	10860	227	3683	3540	1755	1272	903
9L11CVA360S4	420	360	288	Very heavy	13110	240	4193	4050	2070	1500	1065
9L11CHA372S4	420	372	297.6	Medium & heavy	10860	230	3683	3540	1755	1272	903
9L11CVA372S4	420	372	297.6	Very heavy	13110	243	4193	4050	2070	1500	1065
9L11CHA378S4	420	378	302.4	Medium & heavy	10860	231	3683	3540	1755	1272	903
9L11CVA378S4	420	378	302.4	Very heavy	13110	244	4193	4050	2070	1500	1065
9L11CHA390S4	420	390	312	Medium & heavy	11610	238	3853	3710	1860	1348	957
9L11CVA390S4	420	390	312	Very heavy	13110	246	4193	4050	2070	1500	1065
9L11CHA396S4	420	396	316.8	Medium & heavy	11610	239	3853	3710	1860	1348	957
9L11CVA396S4	420	396	316.8	Very heavy	13110	247	4193	4050	2070	1500	1065
9L11CMA420S4	420	420	336	Medium & heavy	12360	248	4023	3880	1965	1424	1011
9L11CVA420S4	420	420	336	Very heavy	13110	252	4193	4050	2070	1500	1065

\* Linear insulation withstand for comparison based on sum of units

## 9L11C Class 4 Protective Characteristics

Ur	Uc	PREVIOUS DUTY TOV (kV)			SWITCHING IMPULSE RESIDUAL VOLTAGE (kV)				MAXIMUM 8/20 RESIDUAL VOLTAGE AT INDICATED CURRENT (kV)					
		1 S	10 S	100 S	0.25 kA	0.50 kA	1.0 kA	2.0 kA	1.5 kA	2.5 kA	5 kA	10 kA	20 kA	40 kA
27	21.6	30	28	26	53	55	56	58	57	59	61	64	68	75
30	24.0	33	31	29	59	61	63	64	63	65	68	71	76	84
33	26.4	36	34	32	65	67	69	70	69	72	74	78	83	92
36	28.8	40	37	35	71	73	75	77	75	78	81	85	91	100
39	31.2	43	40	38	76	79	81	83	81	85	88	92	98	108
42	33.6	46	43	41	83	85	88	90	88	92	95	99	106	117
48	38.4	53	49	47	94	97	100	102	101	104	108	113	121	134
51	40.8	56	53	49	100	103	106	109	107	111	115	120	129	142
54	43.2	59	56	52	106	109	112	115	113	117	121	127	136	150
60	48.0	66	62	58	118	121	125	128	125	130	135	141	151	167
54	43.2	59	56	52	106	109	112	115	113	117	121	127	136	150
66	52.8	73	68	64	129	133	137	140	138	143	148	155	166	183
72	57.6	79	74	70	141	145	149	153	150	156	161	169	181	200
75	60.0	83	77	73	147	151	156	159	156	162	168	176	189	208
78	62.4	86	80	76	152	157	162	166	162	169	175	183	196	216
81	64.8	89	83	79	159	164	169	173	170	176	182	191	205	225
84	67.2	92	87	81	165	170	175	179	176	183	189	198	212	234
90	72.0	99	93	87	176	182	187	192	188	196	202	212	227	250
96	76.8	106	99	93	188	194	200	204	201	208	216	226	242	267
90	72.0	99	93	87	176	182	187	192	188	196	202	212	227	250
96	76.8	106	99	93	188	194	200	204	201	208	216	226	242	267
108	86.4	119	111	105	211	217	224	230	225	234	242	254	272	300
120	96.0	132	124	116	235	241	249	255	250	260	269	282	302	333
132	100.8	145	136	128	258	265	274	280	275	286	296	310	332	366
138	110.4	152	142	134	269	277	286	293	287	299	309	324	347	382
108	86.4	119	111	105	211	217	224	230	225	234	242	254	272	300
120	96.0	132	124	116	235	241	249	255	250	260	269	282	302	333
132	105.6	145	136	128	258	265	274	280	275	286	296	310	332	366
138	110.4	152	142	134	269	277	286	293	287	299	309	324	347	382
144	115.2	158	148	140	281	289	298	305	300	311	322	338	362	399
132	105.6	145	136	128	258	265	274	280	275	286	296	310	332	366
162	129.6	178	167	157	317	326	336	344	338	351	363	381	408	449
168	134.4	185	173	163	328	338	348	357	350	364	377	395	423	466
180	144.0	198	185	175	352	362	373	382	375	390	403	423	453	499
192	153.6	211	198	186	375	386	398	407	400	415	430	451	483	532
198	158.4	218	204	192	386	398	410	420	412	428	443	465	498	548
216	172.8	238	222	210	421	433	447	458	449	467	483	507	543	598
228	182.4	251	235	221	445	457	472	483	474	493	510	535	573	631
216	172.8	238	222	210	421	433	447	458	449	467	483	507	543	598
228	182.4	251	235	221	445	457	472	483	474	493	510	535	573	631

# Polymer Class 4

## 9L11C Class 4 Protective Characteristics

Ur	Uc	PREVIOUS DUTY TOV (kV)			SWITCHING IMPULSE RESIDUAL VOLTAGE (kV)				MAXIMUM 8/20 RESIDUAL VOLTAGE AT INDICATED CURRENT (kV)					
		1 S	10 S	100 S	0.25 kA	0.50 kA	1.0 kA	2.0 kA	1.5 kA	2.5 kA	5 kA	10 kA	20 kA	40 kA
240	192.0	264	247	233	469	482	497	509	500	519	537	564	604	665
258	206.4	284	266	250	503	518	534	547	537	558	577	606	649	714
264	211.2	290	272	256	515	530	547	560	549	571	591	620	664	731
258	206.4	284	266	250	503	518	534	547	537	558	577	606	649	714
264	211.2	290	272	256	515	530	547	560	549	571	591	620	664	731
276	220.8	304	284	268	538	554	571	585	574	597	617	648	694	764
288	230.4	317	297	279	562	578	596	610	599	622	644	676	724	797
312	249.6	343	321	303	608	626	645	661	648	674	697	732	784	863
330	264.0	363	340	320	644	662	683	700	686	713	738	775	830	913
336	268.8	370	346	326	655	674	696	712	699	726	752	789	845	930
360	288.0	396	371	349	702	722	745	763	748	778	805	845	905	996
372	297.6	409	383	361	725	746	770	788	773	804	832	873	935	1029
378	302.4	416	389	367	737	758	782	801	785	817	845	887	950	1045
390	312.0	429	402	378	760	782	807	826	810	842	872	915	980	1078
396	316.8	436	408	384	772	795	820	839	824	856	886	930	996	1096
420	336.0	462	433	407	819	843	869	890	873	908	939	986	1056	1162

For more information, visit [governova.com/grid-solutions](https://governova.com/grid-solutions)

TRANQUELL is trademark of General Electric Company. ANSI is a registered trademark of American National Standards Institute, Incorporated. IEC is a registered trademark of Commission Electrotechnique Internationale. IEEE is a registered trademark of the Institute of Electrical Electronics Engineers, Inc.

GE Vernova reserves the right to make changes to specifications of products described at any time without notice and without obligation to notify any person of such changes.

© 2025 GE Vernova and/or its affiliates. All rights reserved. GE and the GE Monogram are trademarks of General Electric Company used under trademark license.



**GE VERNOVA**

GEA-31947(E)  
English  
250725