

GL 310, GL 311, AND GL 312

Live Tank Circuit Breakers from 100 kV to 145 kV

The Right Choice for Temperatures Down to -60°C / -76°F

Live tank circuit breakers for outdoor installation are designed for temperatures down to -60°C / -76°F and feature the latest technologies in interrupter chambers and spring-operated mechanisms. For example, the latest double-motion technology effectively reduces the opening energy by approximately 65%.

Components

- Interrupter chamber with integral double-motion technology and self-blast system
- Pressure relief system for passive protection of substation and personnel
- Field-proven, temperature-compensated density monitor with two-stage transducer and three-color dial
- Easy access to the SF₆ filling connection (DIL0 type)
- SF₆ non-return (check) valve on each pole column
- Protected opening springs inside each pole column
- Hot-dip galvanized steel parts
- Mechanism housing made completely of aluminum
- Reliable spring-operated mechanism with position indicator clearly visible from outside

Installation and Maintenance

- Preset at factory before shipping - no adjustments necessary during installation and commissioning
- Pole units pre-filled with SF₆ at factory before shipping
- Independent disassembly of the interrupter chamber without having to remove the entire pole column
- Single-pole operated circuit breakers partially pre-assembled before delivery (base frame with mounted and wired mechanisms)

Testing

Grid Solutions' live tank circuit breakers meet national and international requirement standards. This has been confirmed by comprehensive type tests according to the latest IEC, GOST, and ANSI standards.



High Performance

Live tank circuit breakers ensure a high level of reliability every day.

Even under extreme conditions and climates or in highly active seismic areas, customers can count on live tank circuit breakers made by GE Vernova's Grid Solutions business.

Key Benefits

- High reliability even in the coldest regions of the world: down to -40°C / -40°F with pure SF₆ and down to -60°C / -76°F with gas mixture
- Quick and easy installation and commissioning
- Long maintenance intervals
- SF₆-free live tank circuit breakers using a CO₂-O₂ gas mixture instead

Quality

The entire development and production procedures are fully compliant with the latest ISO 9001, ISO 14001 and OHSAS 18001 quality standards. This ensures a high quality of our products and services and is confirmed by regular audits.

CO₂-O₂ Gas Mixture

Grid Solutions has developed a SF₆-free 145 kV live-tank circuit breaker, GL312c, which reduces the impact of the gas on global warming by far more than 99% compared to SF₆, using a CO₂-O₂ gas mixture instead of SF₆. This new circuit breaker is part of GRIDEA, our portfolio of solutions to decarbonize the high voltage grids.

Dimensions

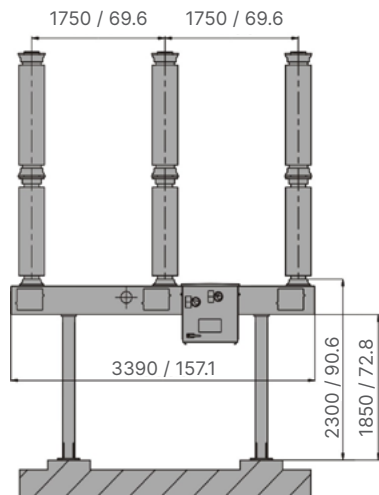

GL 311/312 F1/4031 P
(Dimensions in mm / inches)

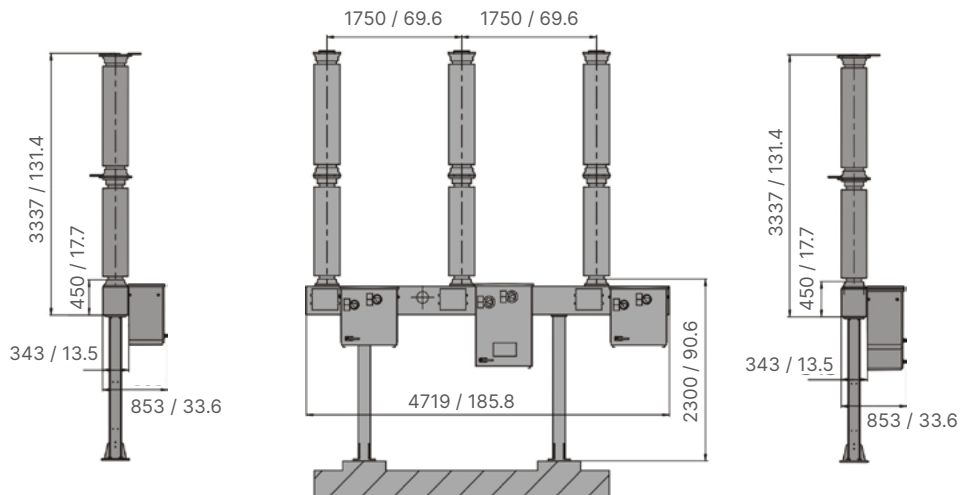

GL 311/312 F3/4031 P
(Dimensions in mm / inches)

Ratings

BREAKER TYPE	GL 310 F1/4031 P GL 310 F3/4031 P GL 310 F3/4040 P	GL 311 F1/4031 P GL 311 F3/4031 P GL 311 F3/4040 P	GL 312 F1/4031 P GL 312 F3/4031 P GL 312 F3/4040 P
Rated voltage	100 kV	123 kV	145 kV
Rated frequency	50/60 Hz	50/60 Hz	50/60 Hz
Rated normal current	up to 4,000 A	up to 4,000 A	up to 4,000 A
Rated short-circuit break current	up to 40 kA	up to 40 kA	up to 40 kA
Rated short-circuit making current Rated closing, latching and short time carrying current	108 kA	108 kA	108 kA
Transformer Limited Fault (TLF)	4 – 12 kA	4 – 12 kA	4 – 12 kA
Rated duration of short-circuit	3 s	3 s	3 s
Opening time	28 ms	28 ms	28 ms
Break time	50 ms / 2.5 cycles @ 50 Hz - 3 cycles @ 60 Hz	50 ms / 2.5 cycles @ 50 Hz - 3 cycles @ 60 Hz	50 ms / 2.5 cycles @ 50 Hz - 3 cycles @ 60 Hz
Closing time	≤ 70 ms	≤ 70 ms	≤ 70 ms
Average ambient temperature *	-40°C / -40°F up to +40°C / +104°F	-40°C / -40°F up to +40°C / +104°F	-40°C / -40°F up to +40°C / +104°F
Design altitude *	1,000 m.a.s.l. / 3,280 ft	1,000 m.a.s.l. / 3,280 ft	1,000 m.a.s.l. / 3,280 ft

*Standard values according to IEC. Temperatures down to -60°C / -76°F, up +50°C / +122°F and higher design altitudes are available upon request.

Technical Characteristics

- **Spring-operated mechanism/degree of protection:**
FK 3/IP 55
- **Rated operating sequence:**
O-0.3s-CO-3min-CO resp. CO-15s-CO
- **Rated supply voltage:**
from 24 V up to 250 V dc/ac

Product Options

- Composite insulators
- More phase center distances available on request
- Monitoring system
- Point-on-wave controller (F3/IPO)

Gas Data*

The functioning of this equipment relies upon SF₆, a fluorinated greenhouse gas.

	SF ₆
Average mass of gas/mixture in the equipment (kg / lbs)*	8.8 / 19.4
GWP ₁₀₀ of gas/mixture (CO ₂ -equivalent)	24,300
CO ₂ -eq of gas/mixture in the equipment (t _{CO₂-eq} / short tons _{CO₂-eq})*	213.8 / 235.7

*For information purposes only. It varies depending on the equipment considered.

For more information, visit
governova.com/grid-solutions



© 2026 GE Vernova and/or its affiliates. All rights reserved. GE and the GE Monogram are trademarks of General Electric Company used under trademark license.

GEA-33288B(E)
English
260430