



1.0 INTRODUCTION

This guide provides installation and startup instructions for the MDS Orbit X-MR. MDS Orbit X is a highly secure, flexible industrial router for critical applications. MDS Orbit X offers advanced networking capabilities including concurrent bridging and routing (L2/L3), route failover, advanced QoS and GRE tunneling to reliably enable the transport of SCADA and other critical automation protocols over cellular. The MDS Orbit X's advanced cyber security capabilities include IPSec VPNs, stateful firewalling, MAC filtering, secure boot and tamper detection. It further packs a flexible Terminal Server to transport serial/SCADA protocols over IP efficiently. The GUI device manager uses configuration wizards to simplify provisioning.

The MDS Orbit X-MR (Figure 1) supports multiple technologies in a single, industrial package, without the need for additional modules or add-ons. In addition, wired serial, Ethernet and USB interfaces are provided at the front panel, reducing network cost and complexity.



Figure 1: MDS Orbit X-MR Sample Unit, Showing Faceplate

1.1 Additional Resources

This Setup Guide covers the essential installation and startup instructions for the MDS Orbit X-MR. GE Vernova MDS manuals, Setup guides, Firmware, Release Notes, Drivers and Application Notes are available free of charge at: <https://www.gevernova.com/grid-solutions/automation/critical-infrastructure-communications>

2.0 INSTALLATION

2.1 Main Requirements

⚠ WARNING: When the unit is to be installed in hazardous locations, use only the Serial or Ethernet connections on the unit's front panel. Do not use the USB port in hazardous locations.

There are three main requirements for installation:

- Adequate and stable primary power (10-36 VDC).
- Efficient and properly installed antenna(s).
- Correct interface connections between the unit and associated data equipment.

2.2 Installation Steps

Installation details for the product may vary, depending on site-specific factors. The steps here provide the basic tasks needed at most sites.

1. **Mount the unit.** Attach the supplied brackets to the bottom of the case (if not already attached), using the screws provided. Mounting bracket dimensions are shown in Figure 2. If DIN Rail mounting brackets are to be used, consult the *Technical Manual* for details.

NOTE: To prevent moisture from entering the unit, do not mount the case with the cable connectors pointing up. Also, dress all cables to prevent moisture from running along the cables and into the enclosure.

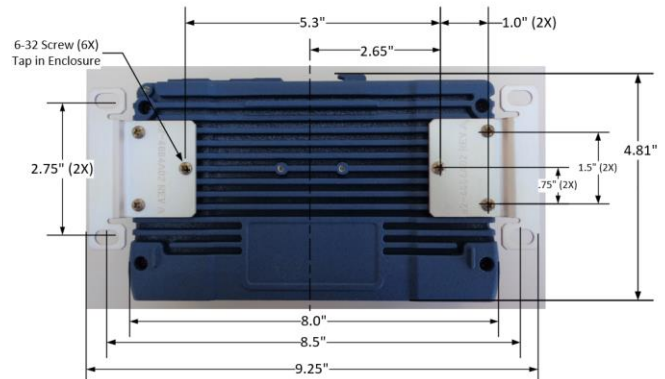

Figure 2: MDS Orbit X-MR Mounting Bracket Dimensions

2. **Install the antennas and feedlines.** The antenna(s) used must be designed to operate in the appropriate frequency band and be mounted in a location providing a clear path to its desired wireless connection point. Antennas should be mounted away from large masses of metal and other obstructions. For most public cellular networks, connect antennas to CELL1 and CELL3 at a minimum. See *Technical Manual* for comprehensive antenna port functionality.
When remotely mounted antennas are used, coaxial feedlines should be low loss and be kept as short as possible. The recommended antennas for use with MDS Orbit X-MR are 5G/LTE MIMO 4x4, 5G/LTE MIMO 2x2, or equivalent.
Proper grounding techniques should be applied. As an added convenience, there is a tapped 6-32 hole on the underside of the unit that can be used with a 1/4" screw and braid or ground strap.
3. **Connect the data equipment.** Connection may be made using any combination of **Serial** protocols (RS-232/RS-485), **Ethernet** signaling, or **USB**. Refer to the *Technical Manual* for wiring and connection details.
 - **Serial connection:** Attach data equipment to a front panel COM port. The unit is hardwired as a DCE device; thus, a straight-through Ethernet cable can be used with an RJ45 to DB9-F adapter (GEV-MDS part #: 73-2434A25).
 - **Ethernet connection:** Attach data equipment to a front panel ETH port. The auto-sensing MDIX feature allows either a straight-through or crossover cable to be used. The ports support 10/100/1000Mbps.
 - **USB connection:** Attach computer or data equipment to the front panel USB-C port. The unit supports USB 3.0.
4. **Connect primary power.** Input power must be 10 to 36 VDC and capable of providing at least 6 watts. A power connector

with clasps is provided (Figure 3: DC Power Connector). A connector with screw retention is also available.

Strip the wire leads to 6 mm (1/4 inch) and insert them into the wire ports. Be sure to observe the proper polarity. The wire leads are secured with spring tension.



Figure 3: DC Power Connector (73-1194A85)

CAUTION: The unit is designed for negative-ground power systems only. The power supply should be equipped with NEC Class 2 overload protection to guard against a short circuit between its output terminals and the unit's power connector.

3.0 UNIT CONFIGURATION

3.1 Default Settings

As shipped from the factory, the unit is configured with a set of pre-defined defaults.

- All LAN ports in the Bridge with Default Ethernet IP address: **192.168.1.1/24**
- Firewall/NAT/DNS proxy enabled
- DHCP server enabled (range: 192.168.1.2 - 192.168.1.10)

This configuration allows connection of a PC via a LAN/ETH port and access to the Internet via cellular, if equipped and supported by a suitable service plan.

3.2 Connecting via Ethernet/LAN (Web)

The configuration PC may be connected to the unit by hardwired cable (USB, serial or Ethernet). The following steps describe an Ethernet connection to the built-in web server. This connection can be made using the factory default information above. The initial sign-in prompt using the web interface appears as shown below:

1. Enter the Username (default is **admin**).
2. Enter the Password (default is **unique to the unit and is located on the bottom of the device**). Press "Sign in". Upon successful login, the Device Overview page appears.

3. The Device Overview / Status page (Home) shows device and networking status. Configuration is done by accessing other pages.
4. Key items that should be set/reviewed:
 - Create one-time programmable passwords for device recovery
 - Change login passwords (to maintain security)
 - Evaluate default factory configuration and lock it down to required security level

Additional information on the above items is available by accessing the *Technical Manual*.

3.3 Connecting via Serial or SSH (CLI / Console)

The configuration PC may be connected to the unit by serial, USB, or Ethernet/LAN. The following steps describe a cabled serial cable connection, as illustrated in Figure 4.

Note that not all PCs have a serial port. If one is not available, a USB-to-Serial adapter and appropriate driver software may be used to provide serial connectivity.

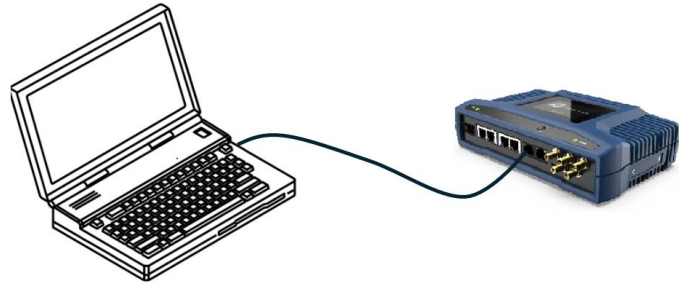

Figure 4. Setup for PC Configuration—Serial Port (RJ-45 adapter is required)

1. Connect a PC to one of the unit's COM ports and establish a console terminal session using PuTTY or a similar terminal emulator. The following parameters must be used for a factory defaulted unit: 115200 bps, 8 bits, no parity, one stop bit (8N1), flow control disabled, VT100 emulation.

NOTE: As an alternative, the unit may be configured via a *Secure Shell (SSH) terminal*. The steps below are for CLI over serial or SSH. For enhanced security, the unit does *not* support Telnet configuration.

2. Press the **ENTER** key to receive the **login** prompt. The COM LEDs flash to indicate data communications (if using serial)
3. At the **Login** prompt, enter the username (**admin** is the default) and press **ENTER**
4. At the **Password** prompt, enter the password (default is **unique to the unit and is located on the bottom of the device**). Press **ENTER**. Upon successful login, the connection message appears.
5. To view status, enter **show** followed by subsequent commands (use tab to see options). For example, **show system firmware** will provide information regarding firmware packages.
6. Enter configuration mode by typing **configure** followed by the **ENTER** key.
7. Review and configure all key settings for the required application. Built-in help is available by pressing the **Tab** key. A summary of all unit settings may be viewed by entering the **% show | details** command.
8. Save configuration changes by entering the **commit** command. Exit configuration mode by entering **exit**
9. When finished, log out of the console session (**exit**) and disconnect the PC

Key items that should be set/reviewed for the unit are:

- Create one-time programmable passwords for device recovery
- Change login passwords (to maintain security)
- Evaluate default factory configuration and lock it down to required security level

Tab-completion is a useful feature that presents CLI users with assistance while typing commands. Depending on the text that was already entered, tab-completion will display different possible completions. When the **Tab** key is pressed and no text has been entered, the CLI shows all possible commands that can be typed.

3.4 Cellular Setup and Connection

The MDS Orbit X is available with multiple cellular carrier options. To find the correct configuration option for your needs, contact your local sales representative.

The MDS Orbit X-MR has two SIM card ports, SIM-A and SIM-B, that are located behind a removable, weather-sealed cover on the side of the unit. Use a small Phillips screwdriver to remove the cover screws.

SIM-A is located closer to the front of the device. The printed label of the SIM card must face down (connectors up) with the cut-off corner on the right side.

Insert SIM cards with the power OFF. Push the card in until the spring mechanism holds (push on the card again to release/remove).

Information regarding the cell interface (including IMEI and ICCID) can be found in the Cell Status section. Navigate to:

Home / Network / Interface / Cell

or type the following at the CLI prompt:

```
> show interfaces-state interface Cell
```

For most setups all that is needed is to set the Access Point Name (APN) and configure the proper SIM slot.

On the Web UI navigate to:

Network / Interfaces / Cell / Basic Config / Cellular / Connection Profile

Configure the enter the APN and Sim Slot, then the green **Save** button at the top of the window. Or, use the following commands at CLI prompt:

```
> configure
% set interfaces interface Cell enable true
% set interfaces interface Cell cell-config connection-profile PROFILE-1 bearer-config apn <APN>
% set interfaces interface Cell cell-config connection-profile PROFILE-1 sim-slot <SIM-A or SIM-B>
% commit and-quit
```

3.5 LED Functions

In-service operation of the unit is completely automatic. The only operator actions required are to apply power and observe the LEDs for proper indications. Table 1 summarizes the unit's LED functions.

Table 1: Description of LED Status Indicators

LED Name	LED State	Description
PWR	OFF	No power to unit
	Green: Solid On	Unit is powered / no alarms
	Red: Slow Flash	Initializing / boot-up
	Red: Fast Flash	Alarm State
ETHX (Ethernet)	G:ON / Y:OFF	Linked at 1000 Mbps
	G:OFF / Y:ON	Linked at 10/100 Mbps
	G:OFF / Y:OFF Flashing	Not Linked Data Traffic
COMX (Serial)	OFF	No serial traffic
	Green: Flash	RXD Activity (DCE Output)
	Yellow: Flash	TXD Activity (DCE Input)
		(No link indicator for Com ports)
RADIO (Cell)	Off	Cellular Interface Disabled
	Yellow	No cellular connection (searching)
	Blue	5G Connected / Signal is GOOD
	Violet	5G Connected / Signal is FAIR
	Violet Flash	5G Connected / Signal is POOR
	Magenta	4G Connected / Signal is GOOD
	Orange	4G Connected / Signal is FAIR
Orange Flash	4G Connected / Signal is POOR	

Notes for Above:

- "G" = Green; "Y" = Yellow/Amber
- ETH LEDs: Green is the left LED assuming connector tab is facing down
- COM LEDs: Yellow is the left LED assuming connector tab is facing up

4.0 TROUBLESHOOTING

For proper operation, all units must meet the basic requirements which follow. Check these items first when troubleshooting:

- Adequate and stable primary power
- Secure connections (antennas, data and power)
- A clear wireless transmission path between associated units
- An efficient, properly installed antenna system
- Proper configuration of unit settings
- Correct interface between the unit and other equipment

4.1 LEDs & Event Logging

The unit's LED indicator panel can provide useful information when troubleshooting. Refer to Table 1 for LED status indicators.

An event (such as an alarm condition) is a notification that something significant occurred on the unit. Events can be stored locally and/or transported to a remote server (e.g. Syslog)

5.0 COM PORT REFERENCE

The COM port (Figure 6) is commonly used to connect an external DTE telemetry device to the unit, supporting either the RS-232 or RS-485 (balanced) format, depending on how the device is configured. The unit supports data rates of 300, 1200, 2400, 4800, 9600, 19200, 38400, 57600, 115200 and 230,000 bps (asynchronous data only).

This connector mates with a standard RJ-45 plug available from many electronics parts distributors.

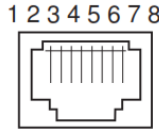

Figure 5. COM Connector (RJ-45)
As viewed from outside the unit.

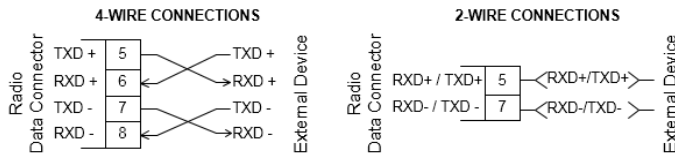

Figure 6. 4-wire & 2 wire connections for RS-485 modes

5.1 Pin Descriptions

The tables below provide pin descriptions for the COM connectors when operating in RS-232 mode and RS-485 mode, respectively.

Table 2: COM1 Pin Descriptions—RS-232

Pin #	Input/ Output	Pin Description
1	Reserved	-- (Do not connect)
2	OUT	DCD (Data Carrier Detect)
3	Reserved	-- (Do not connect)
4	Ground	Connects to ground (negative supply potential) on chassis
5	OUT	RXD (Received Data)—Supplies received data to the connected device
6	IN	TXD (Transmitted Data)—Accepts TX data from the connected device
7	OUT	CTS (Clear to Send)
8	IN	RTS (Request to Send)

NOTE: The unit is hardwired as a DCE device

Table 3. COM2 Pin Details (RS-485)

Pin #	Input/ Output	Pin Description
1	Reserved	-- (Do not connect)
2	OUT	DCD (Data Carrier Detect)
3	Reserved	-- (Do not connect)
4	Ground	Connects to ground (negative supply potential) on chassis

5	OUT	TXD+/TXB (Transmitted Data +)—Non-inverting driver output. Supplies received payload data to the connected device.
6	IN	RXD+/RXB (Received Data +) — Non-inverting receiver input. Accepts payload data from the connected device.
7	OUT	TXD-/TXA (Transmitted Data -) — Inverting driver output. Supplies received payload data to the connected device.
8	IN	RXD-/RXA (Received Data -) — Inverting receiver input. Accepts payload data from the connected device.

Technical Assistance

Technical assistance is available by contacting our Technical Services team at GE Vernova Grid Solutions. Find contact information at the following website:

<https://www.governova.com/grid-solutions/contact>

Documentation

GE Vernova MDS manuals, Setup guides, Firmware, Release Notes, Drivers and Application Notes are available free of charge at: <https://www.governova.com/grid-solutions/automation/critical-infrastructure-communications>

REGULATORY AND PRODUCT INFORMATION—MDS ORBIT X-MR

Hazardous Locations Notice



When installed in hazardous locations, use only the serial and Ethernet connections on the unit's front panel. Do *not* use the USB port in hazardous locations.

EXPLOSION HAZARD. DO NOT DISCONNECT WHILE THE CIRCUIT IS LIVE OR UNLESS THE AREA IS FREE OF IGNITIBLE CONCENTRATIONS.

Hazardous Location Marking

1. Class I, Division 2, Groups A, B, C, and D
2. Temperature Code: T3
3. Ambient Temperature Range: $-40\text{ }^{\circ}\text{C} \leq T_{amb} \leq +70\text{ }^{\circ}\text{C}$

RF Exposure Notice

To comply with RF exposure requirements, the antenna shall be installed to ensure a minimum separation distance ≥ 20 cm from persons. The antenna may not be co-located or operated in conjunction with other transmitting devices.

Approved Antennas

Only approved antennas may be used on the unit's RF output connectors; an example is listed below. The use of non-approved antennas may result in a violation of FCC rules and subject the user to FCC enforcement action.

Antenna Application	Manufacturer* Part Number	GE Vernova MDS Part Number
5G/LTE omni, MIMO 4x4, 1.5m SMA	AO5G4-GG15	97-3194A54
5G/LTE omni, MIMO 4x4, 5m SMA	A054G-GG	97-3194A55
5G/LTE omni, MIMO 2x2	AO5G2-G	(Consult Sales)

*<https://www.qwireless.com/products/5g-antennas>

Servicing Precautions

When servicing energized equipment, be sure to wear appropriate Personal Protective Equipment (PPE). During service, situations could arise where the appropriate PPE would alleviate or decrease the severity of potential injury. When servicing radios, all workplace regulations and other applicable standards for live electrical work should be followed to ensure personal safety.



Manual Revision and Accuracy

This manual was prepared to cover a specific version of firmware code. Accordingly, some screens and features may differ from the actual unit you are working with. While every reasonable effort has been made to ensure the accuracy of this publication, product improvements may also result in minor differences between the manual and the product shipped to you. If you have additional questions or need an exact specification for a product, please contact GE Vernova MDS, using the information at the back of this guide. In addition, manual updates can be found on our web site at <https://www.governova.com/grid-solutions/communications/wireless.htm>.

Environmental Information

The manufacture of this equipment has required the extraction and use of natural resources. Improper disposal may contaminate the environment and present a health risk due to hazardous substances contained within. To avoid dissemination of these substances into our environment and to limit the demand on natural resources, we encourage you to use the appropriate recycling systems for disposal. These systems will reuse or recycle most of the materials found in this equipment in a sound way. Please contact GE Vernova MDS or your supplier for more information on the proper disposal of this equipment.

Product Test Data Sheets

Test Data Sheets showing the original manufacturing test results for this unit are available upon request. Contact the GE Vernova MDS using the information at the back of this manual. Serial numbers must be provided for each product where a Test Data Sheet is required.

FCC Class A Notice

This device complies with Part 15 of the FCC Rules. Operation is subject to the following two conditions:

1. This device may not cause harmful interference.
2. This device must accept any interference received, including interference that may cause undesired operation.

Note: This equipment has been tested and found to comply with the limits for a Class A digital device, pursuant to Part 15 of the FCC Rules. These limits are designed to provide reasonable protection against harmful interference when the equipment is operated in a commercial environment. This equipment generates, uses, and can radiate radio frequency energy, and if it is not installed and used in accordance with the instruction manual, it may cause harmful interference to radio communications. Operation of this equipment in a residential area is likely to cause harmful interference, in which case the user will be required to correct the interference at his own expense.

Modifications: Any modifications made to this device that are not approved by GE Vernova MDS LLC, Inc. may void the authority granted to the user by the FCC to operate this equipment.

Industry Canada Notice

This Class A digital apparatus complies with Canadian ICES-003.

Cet appareil numérique de la classe A est conforme à la norme NMB-003 du Canada.

Important EU/UK Information

GE VERNOVA MDS, LLC, Inc. declares that the Orbit X-MR radio equipment complies with:

EU Regulations:

Directive 2014/53/EU (RED)
Directive 2011/65/EU + 2015/863 (RoHS)

UK Regulations:

Radio Equipment Regulations 2017 (SI 2017/1206), amended by SI 2019/666 and SI 2020/223
RoHS Regulations 2012 (SI 2012/3036), amended by SI 2015/3034 and SI 2019/667

Cybersecurity:

The equipment meets cybersecurity standards EN 18031-1 and EN 18031-2 for the RED, and aligns with the UK's NIS Directive and Cyber Essentials scheme.

For the full EU declaration of conformity, visit: https://www.gevernova.com/grid-solutions/resources?prod=ETSI-RED&type=7#&node_id=4678

GE VERNOVA MDS, LLC, Inc. mandates the use of Cat 7 Ethernet cables for the Orbit X-MR radio equipment to ensure full compliance with EU Directive 2014/53/EU (RED) and the UK's Radio Equipment Regulations 2017 (SI 2017/1206), as amended.

The MDS Orbit X-MR industrial router displays the CE mark.

Grounding Requirements

To minimize the chance of damage to the unit and connected equipment, a safety ground (NEC Class 2 compliant) is recommended which bonds the antenna system, chassis, power supply and connected data equipment to a *single-point* ground, keeping all ground leads as short as possible.

Normally, the unit is adequately grounded if the supplied flat mounting brackets are used to mount it to a well-grounded metal surface. If the unit is not mounted to a grounded surface, it is recommended that a safety ground wire be attached to one of the mounting brackets or a screw on the enclosure.

The use of a lightning protector is recommended where the antenna cable enters the building. Bond the protector to the tower/support ground, if possible. All grounds and cabling must comply with applicable codes and regulations.