

MULTILIN EPM 7000

Power Quality & Energy Cost Management

The Multilin™ EPM 7000 Power Quality meter provides revenue class (0.2%) three phase power metering with optional Ethernet, relay, status, and analog output communication modules. This flexible meter can be used for a wide range of high accuracy applications including disturbance recording and power quality studies.

The EPM 7000 is a highly accurate meter providing 0.1% accuracy for voltage and current. The unit's real-time clock provides time stamping of all logs as they are created. Up to 4MB of data can be logged for analysis of historical trends, limit alarms, I/O changes power quality recording and sequence of events.

Key Benefits

- Certified ANSI C12.20 0.2 Accuracy Class and IEC 62053-22 0.2S Energy Measurement Accuracy including High Resolution Frequency Measurements (0.001 Hz)
- Flexible mounting fitting both ANSI and DIN cutouts
- Analyze power quality over long periods of time to improve network reliability through high resolution event and disturbance recording
- Ideal for monitoring industrial power centers, data centers and hospitals due to high accuracy disturbance recording (up to 512 samples/cycle)
- Retrieve archived data, capture past events and analyze disturbances through high resolution data recording (up to 4MB of data logging)
- Flexible communications options including dual Ethernet provides simultaneous Modbus and IEC 61850 or DNP3 providing easy access to meter information and seamless integration into new or existing automation systems
- Upgradable through modular I/O and field upgradable firmware allowing the meter to be easily adapted for changing applications

Applications

- Four quadrant energy and power monitoring for feeders, transformers, reactors and generators
- Power monitoring of LV and MV industrial power systems and motor control centers
- Energy monitoring for commercial buildings and distribution utility applications
- Power Quality & Load Studies supported with data logging



Monitoring & Metering

- Certified ANSI C12.20 0.2 Accuracy Class and IEC 62053-22 0.2S Energy Measurement Accuracy (0.001 Hz)
- Current and Voltage measurements (Ia Ib Ic In, Va Vb Vc Vab Vbc Vca)
- Hz, W, VAR, VA, Wh, VARh, Vah
- Demand: W VAR VA and Power Factor
- Voltage and Current Angles, Load Bar

Power Quality

- Harmonics to the 40th order & total harmonic distortion
- Disturbance recording and waveform capture
- Sag and Swell

Data Logging

- Up to 4MB of Memory
- 3 Assignable Historical logs (up to 64 parameters per log)
- System Events, Limit/Alarm Log, I/O Change Log
- Limits Alarms & Control Capability (option D and higher)

Communications

- Standard RS485 Serial Port (DNP3 and Modbus RTU or ASCII)
- Optional 100BaseT Ethernet (Modbus/DNP3 or Modbus/IEC 61850)
- Front IrDA Port
- Intuitive faceplate programming

Software

- Meter setup via GE Vernova Communicator Software
- Available web server with Ethernet communications option
- Field upgradable Software Options to upgrade functionality post installation.



Overview

The EPM 7000 meter provides revenue class (0.2%) three phase power metering with optional Ethernet, relay, status, and analog output communication modules. This flexible meter can be used for a wide range of high accuracy applications including disturbance recording and power quality studies.

EPM 7000 can easily be mounted in a panel for generator monitoring, substation automation, power quality studies, data recording and more. The meter can also provide data to RTUs, PLCs and other control devices.

The EPM 7000 is a highly accurate meter providing 0.1% accuracy for Voltage and Current. The unit's real-time clock provides time stamping of all logs as they are created. Up to 4 MB of data can be logged for analysis of historical trends, limit alarms, I/O changes power quality recording and sequence of events.

Metering

The following electrical parameters are measured and remotely accessed from the EPM 7000.

Universal Voltage and Current Inputs

This meter allows voltage input measurements 20 Volts to 576 Volts Line to Neutral and up to 721 Volts Line to Line.

This ensures proper meter safety when wiring directly to high voltage systems. The unit will perform to specification on 69 Volt, 120 Volt, 230 Volt, 277 Volt and 347 Volt power systems.

Unique Current Input Connections

EPM 7000 meter uses two current input wiring methods.

- Method One - CT pass through: Directly pass the CT through the meter without any physical termination on the meter. This insures that the meter cannot be a point of failure on the CT circuit. This is preferable to utility users when sharing relay class CTs. No Burden is added to the secondary CT circuit.

- Method Two - Current "Gills": The meter additionally provides ultra-rugged termination pass through bars allowing the CT leads to be terminated on the meter. This also eliminates any possible point of failure at the meter. This method is also a preferred technique for ensuring relay class CT integrity does not get compromised. No terminal blocks are required and this stud based design ensures that CTs will not open under a fault condition.

Through an optional high speed Modbus communications interface, the meter can also provide data to RTUs, PLCs and other control devices at Baud rates ranging from 9600 baud to 57.6 kbaud.

Solid Construction with Mounting

Versatility The EPM 7000 has a rugged design for harsh environment. This is especially important in power generation, utility substation, and critical user applications. The structural and electrical design of this meter was developed based on the recommendations and approvals of many of our utility customers.

EPM 7000 can easily be mounted in a panel for generator monitoring, substation automation and more. The unique dual design combines ANSI and DIN mounting structure and allows easy installation for both new metering applications and retrofit of existing analog meters.

The unit mounts directly in an ANSI C39.1 (4" Round form) or an IEC 92 mm DIN square form.

Future Upgrade Packs

The EPM 7000 is equipped with a virtual firmware based switch that allows feature upgrades through communications even after installation. This allows you to optimize your metering investment. Begin with a standard meter and upgrade it with more functionality as new features are needed, such as data-logging, waveform capture or more memory

Multifunction Metering & Power Quality Monitoring

The EPM 7000 can provide a total picture usage and power quality as different points within a power distribution network on critical infrastructure such as data centers, allowing users to make power related decisions quickly and effectively.

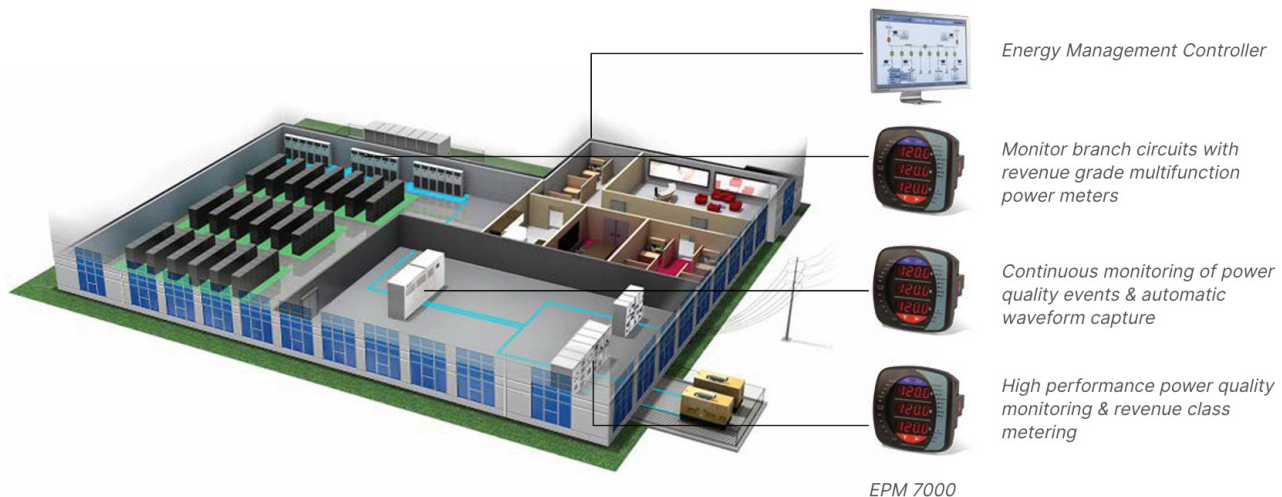

Waveform Options

SOFTWARE OPTION	SAMPLES PER CYCLE	PRE EVENT CYCLES	POST EVENT CYCLES	MAX WAVEFORM PER EVENT	NUMBER OF STORED EVENTS
E	16	32	96	256	85
	32	16	48	128	85
	64	8	24	64	85
F	128	4	12	32	170
	256	2	6	16	170
	512	1	3	8	170

Power Quality

The EPM 7000 can record voltage sag, swell, and current fault events. It records up to 512 samples per cycle, when events occur the meter will record pre and post event activity at a programmable sampling rate. Up to 4MB of storage is available allowing for a maximum of 170 events to be stored. Waveform data is stored in a circular buffer, this means that the meter is always recording.

Data Logging

The EPM 7000 meter offers the capability of having 2MB of date-logging to be used for historical trends, limit alarms, I/O changes power quality recording and sequence of events. The unit has a realtime clock that allows for time stamping of all the data in the instrument when log events are created.

Historical Logs:

- 3 Assignable Historical Logs
- Independently Program Trending
- Up to 64 Parameters per Log

System Events Log:

- Demand Resets
- Password Requests
- System Startup
- Energy Resets
- Log Resets & Reads
- Programmable Settings Changes

I/O Change Log:

- Time Stamped Log of any Relay Output
- Time Stamped Log of Input Status Changes
- 2048 possible events

Limit/Alarm Log

- Provides Magnitude and Duration of an Event
- Time Stamp and Alarm Value provided
- 2048 possible events

Limits Alarms and Control Capability (Option D and higher)

- Any measured parameter
- Up to 16 limits can be selected
- Voltage Imbalance
- Current Imbalance
- Based on percentage full scale settings

Communications

Front Mounted IrDA

All EPM 7000 meters come equipped with Front Mounted IrDA Communications port. This eliminates the need for a communications cable when the technician has an IrDA-equipped PC or a PDA with COPILOT EXT software. The meter can be set-up and programmed through the IrDA connection.

Rear Mounted Serial Port with KYZ Pulse

The RS485 serial interface supports Modbus, and DNP 3.0 at baud rates ranging from 9600 to 57.6K. Also supported are KYZ pulse outputs that are mapped to absolute energy.

Expandable I/O and Communications Capabilities

EPM 7000 meters have two expansion slots used to accept new I/O cards. These slots can be equipped at the factory or in the field. The meter auto-detects installed I/O cards. Up to two cards of any type may be used per meter.

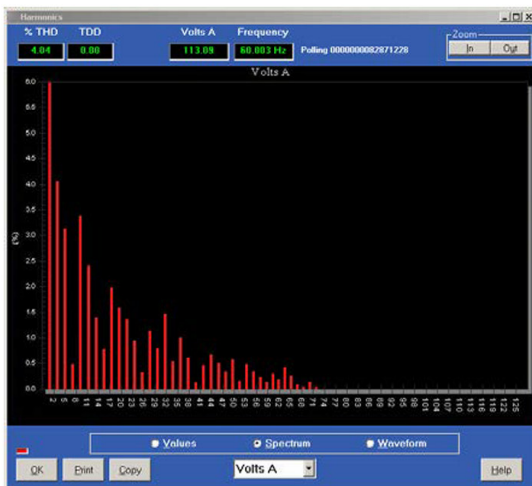

Harmonic Spectrum

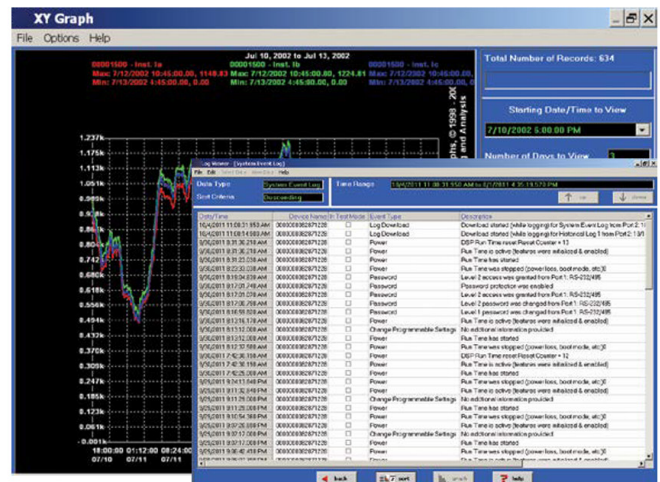

Historical Trending

Expandable I/O Cards

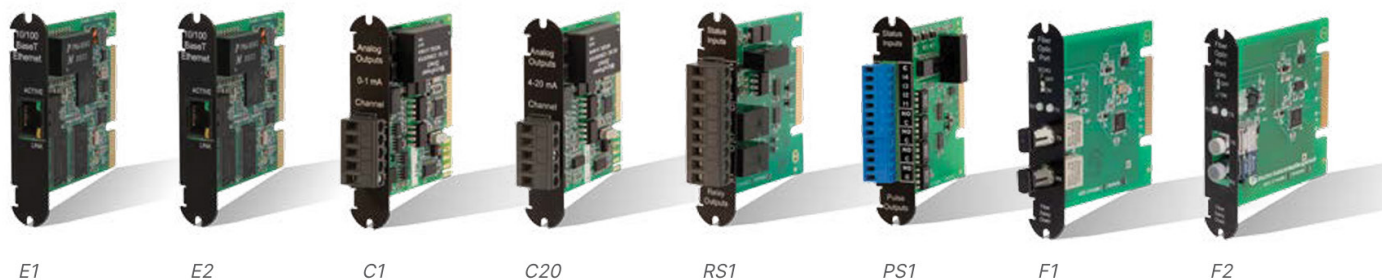

E1:

- 100BaseT Ethernet Card (Modbus, DNP)
- 12 simultaneous Modbus TCP/IP connections
- 5 simultaneous DNP over TCP/IP connections
- Network Time Protocol (NTP) support (Network Clock Sync)
- Embedded web server, Smartphone access compatible
- Available support for dual Ethernet Ports available

E2:

- IEC 61850 Ethernet Card
- Simultaneous Modbus and IEC 61850
- IEC 61850 Support including:-
 - Configurable .CID file-
 - 5 Simultaneous MMS Clients
 - Multiple Logical Nodes-
 - Polled Operation Mode (Queried Reports)
 - Buffered and Unbuffered Reports

C1:

- Four Channel Bi-directional 0-1mA Outputs
- Assignable to any parameter
- 0.1% of Full Scale
- 0 to 10K Ω
- Range $\pm 1.20\text{mA}$

C20:

- Four Channel 4-20mA Outputs
- Assignable to any parameter
- 0.1% of full scale
- 0 – 500 Ω , no accuracy losses
- Loop Powered up to 24VDC

RS1:

- Two Output Relays/Two Status Inputs
- 250VAC/30VDC – 5A Relays, Form C
- Trigger on user set alarms
- Set delays and reset delays
- Status Inputs – Wet/Dry Auto Detect (Up to 150VDC)

PS1:

- Requires Software Option D or higher for limit based alarms and control

PS1:

- Four Pulse Outputs/Four Status Inputs
- Programmable to any energy parameter and pulse value
- Normally Open Contacts, Form A
- 120mA continuous load current
- Status Inputs – Wet/Dry Auto Detect (Up to 150VDC)
- Can function for manual relay control and limit based control
- Requires Software options D or higher for limit based alarms and control

F1:

- Fiber Optic Interface with ST terminations
- Daisy Chain switchable built-in logic mimics RS485 half duplex bus
- ST terminated
- Modbus and DNP 3.0 Protocols available

F2:

- Fiber Optic Interface with Versatile terminations
- Daisy Chain switchable built-in logic mimics RS485 half duplex bus
- Versatile terminated
- Modbus and DNP 3.0 Protocols available.

Embedded Web

- The EPM 7000 with Ethernet (E1,E2 options) includes a secure web server that is viewable from a variety of web browsers. The web server supports multiple simultaneous connections to view the following information:
- Voltage and Current Reading
- Power and Energy Readings
- Power Quantity Information
- General Meter Information



Simultaneous Data Connection through Ethernet and Web Server



Simultaneous Data Connections

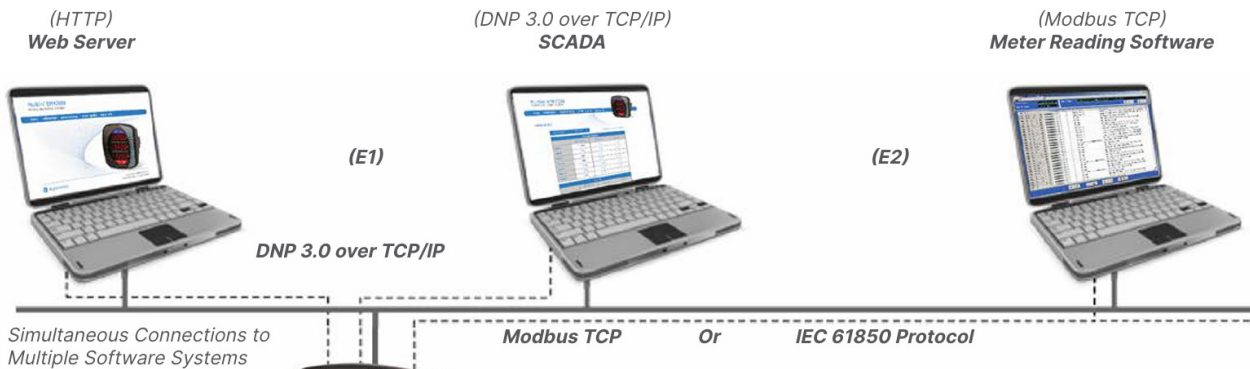

E1 - Web Server, Modbus, DNP

- 100BaseT Ethernet Card (Modbus, DNP)
- 12 simultaneous Modbus TCP/IP connections
- 5 simultaneous DNP over TCP/IP connections
- Network Time Protocol (NTP) support (Network Clock Sync)
- Embedded web server, Smartphone access compatible
- Available support for dual Ethernet Ports available

E2 - Web Server, Modbus, IEC 61850

- IEC 61850 Ethernet Card
- Simultaneous Modbus and IEC 61850
- IEC 61850 Support including:-
 - Configurable .CID file
 - 5 Simultaneous MMS Clients
 - Multiple Logical Nodes
 - Polled Operation Mode (Queried Reports)
 - Buffered and Unbuffered Reports

Embedded Web Server with Smartphone Support



Multilin Meter Enclosure

Expanding existing switchgear or installing new metering capability can be challenging due to space limitations, downtime and installation and equipment costs. GE Vernova's Multilin Meter Enclosure is a pre-wired configured, economical solution for both retrofit expansions and small scale meter installations that allows the expansion of existing switchgear capability without expensive and time-consuming design.

When ordered as a meter option the enclosure provides a factory pre-wired, installation-ready metering solution that further drives energy cost savings, by enabling the measurement of key energy usage information along multiple metering points for new or existing systems.

Ordering the enclosure is simple when selected as an option during meter configuration, ensuring correct pre-wired meter-compatible delivery.

Pre-Wired, Configured and Economical Solution for Retrofit and Small Metering Systems

Easy and Rapid Installation

- Factory pre-wired, installation-ready GE Vernova metering solution eliminates wiring and associated errors for rapid installation
- Extend metering capability with new systems and existing switchgear without system installation downtime

Cost-Effective Retrofit Solution

- Save up to 200% versus the addition of a new switchgear cabinet
- Compact footprint makes effective use of existing allocated space
- Allows new installations or the expansion of existing switchgear capability without expensive, time-consuming designs, eliminating system downtime

Assembly

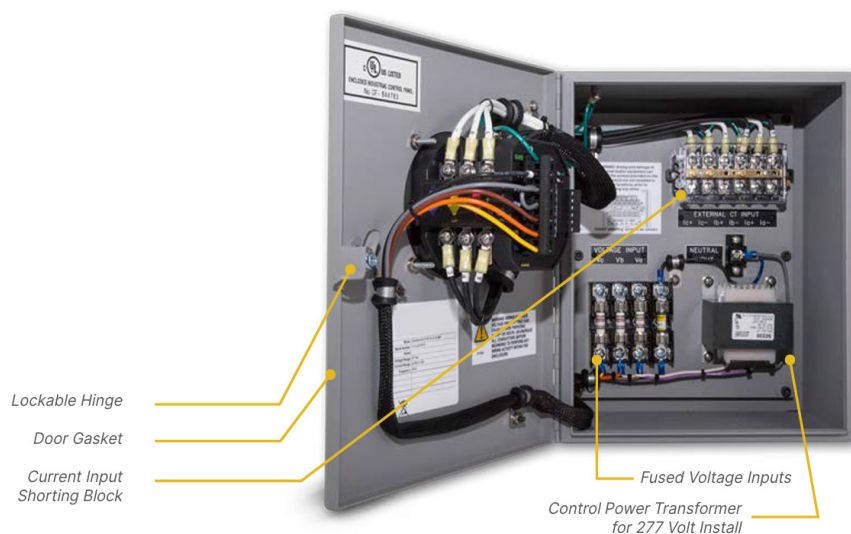

Reliable and Compatible

- Backed by a 10 year warranty
- Simple meter option ordering ensures compatibility with GE Vernova EPM 2000/6010/6000/7000 meters
- Comprehensive factory testing of both meter and enclosure together
- NEMA1 tested and UL/CUL certified

Applications (New and Retrofit installations)

- Industrial Multi-Tenant Monitoring
- Commercial/Residential Buildings
- Healthcare Institutions
- Government Buildings
- Manufacturing
- Educational Campuses



Dimensional Drawings

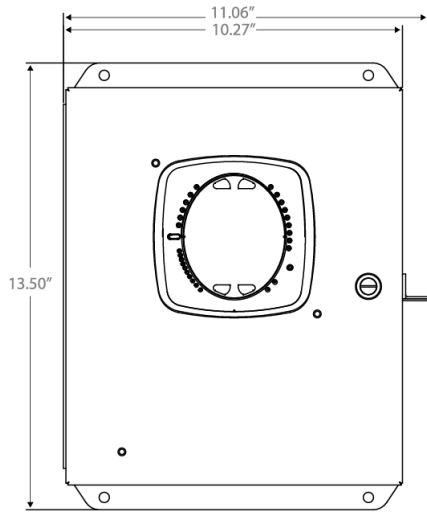

Enclosure Front Dimensions

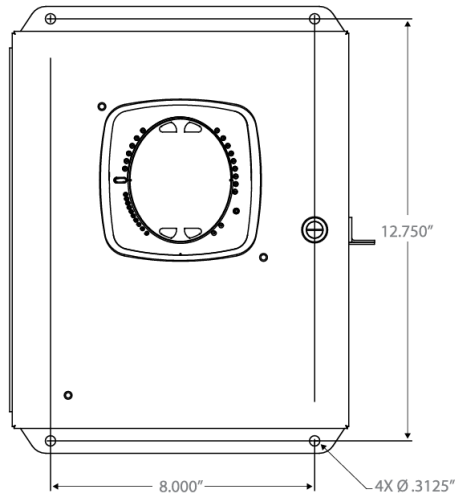

Mounting Hole Dimensions

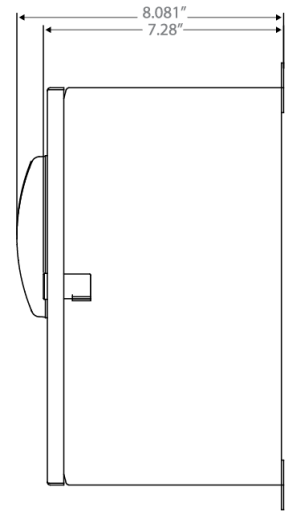

Enclosure Side Dimensions

Dimensions and Mounting

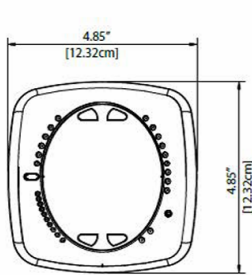

Front View

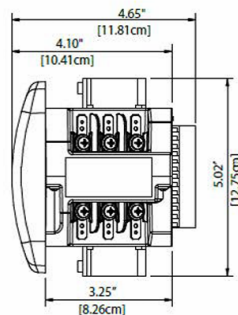

Side View

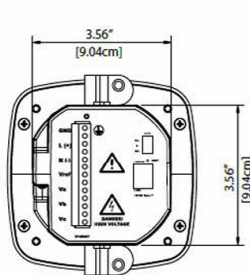

Rear View

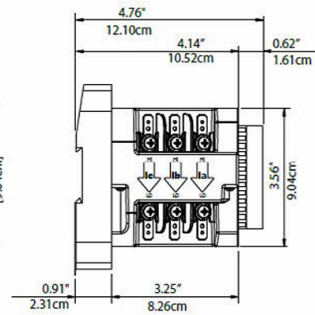

Transducer

User Interface

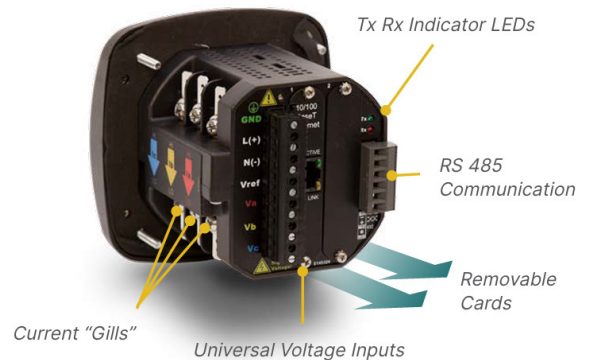

Technical Specifications

VOLTAGE INPUTS

- 20-576 Volts Line to Neutral
- 0-721 Volts Line to Line
- Universal Voltage Input
- Input Withstand Capability – Meets IEEE C37.90.1 (Surge Withstand Capability)
- Programmable Voltage range to any PT ratio
- Supports: 3 Element WYE, 2.5 Element WYE, 2 Element Delta, 4 Wire Delta Systems
- Burden: 0.014W at 120 Volts
- Input Wire Gauge Max (AWG 12 / 2.5 mm²)

CURRENT INPUTS

- Class 10: (0.005 to 11)A, 5 Amp Nominal
- Class 2: (0.001 to 2)A, 1A Nominal Secondary
- Fault Current Withstand: -
 - 100 Amps for 10 Seconds -
 - 300 Amps for 3 Seconds -
 - 500 Amps for 1 Second
- Continuous current withstand: -
 - 20A for Screw Terminated or Pass Through Current Connections
- Programmable Current to Any CT Ratio
- Burden 0.005VA Per Phase
- Max at 11 Amps
- Pickup Current:
 - 0.1% of Nominal
 - Class 10: 5mA
 - Class 2: 1mA
- Pass Through Wire Gauge Dimension: 0.177" / 4.5mm

ISOLATION

- All Inputs and Outputs are Galvanically Isolated to 2500 Volts AC

SENSING METHOD

- True RMS
- Sampling at 400+ Samples per Cycle on all channels measured readings simultaneously
- Waveform up to 512 Samples/cycle
- Harmonics resolution to 40th order

UPDATE RATE

- Watts, VAR and VA-100msec
- All other parameters 1sec

POWER SUPPLY

- HI : 90-265VAC and 100-370VDC
- LDC Option: 18-60VDC (24-48VDC Systems)

STANDARD COMMUNICATIONS

- 2 Com Ports (Back and Faceplate)
- RS485 Communications Port
- Through Backplate
- Protocol Modbus RTU or ASCII
- Com Port Baud Rate: 9600 to 57.6K
- Com Port Addresses: 001-247
- 8 Bit, No Parity
- IrDA -
 - Through Faceplate
- Modbus RTU, ASCII or DNP 3.0, IEC 61850 Protocols

METERING ACCURACY

Measured	Accuracy% of Reading	Display Range
Voltage L-N	0.1%	0-9999 V or kV
Voltage L-L	0.2%	0-9999 Scalable V or kV
Current	0.1%	0-9999 Amps or kAmps
+/- Watts Mwatts	0.2%	0-9999 Watts, kWatts,
+/- Wh	0.2%	5-8 Digits Programmable
+/-VARs MVARs	0.2%	0-9999 VARs, kVARs
+/-VARh	0.2%	5-8 Digits Programmable
VA	0.2%	0-9999 VA, kVA, MVA
VAh	0.2%	5-8 Digits Programmable
PF	0.2%	+/- 0.5 – 1.0
Frequency	+/- 0.03 Hz	45 –65 Hz
%THD	+/- 2.0%	1 to 99.99%
% Load Bar	+/- 1 Segment	(0.005 to 6) A

KYZ PULSE

- Type Form C Contact
- On Resistance: 35Ω Max
- Peak Voltage: 350VDC
- Continuous Load Current: 120mA
- Peak Load Current: 350mA (10ms)
- Off State Leakage Current @ 350VDC: 1μA

DIMENSIONS & SHIPPING

- Weight: 2lbs
- Basic Unit: H4.85x W4.82 xL4.25 inches
- Mounts in 92mm Square DIN or ANSI C39.1 Round Cut-outs
- Shipping Container Dimensions: 6" cube

ENVIRONMENTAL

- Storage: -20°C to +70°C
- Operating: -20°C to +70°C
- Humidity: to 95% RH Non Condensing
- Faceplate Rating: NEMA12 (Water Resistant) Mounting Gasket Included

COMPLIANCE

- IEC 687 (0.2% Accuracy)
- ANSI C12.20 (0.2% Accuracy)
- ANSI (IEEE) C37.90.1 Surge Withstand
- ANSI C62.41 (Burst)
- IEC 61000-4-2: ESD
- IEC 61000-4-3: Radiated Immunity
- IEC 61000-4-4: Fast Transient

APPROVALS

- ISO: Manufactured to an ISO9001 registered program
- UL: Listed under E250818
- CE: Conforms to European CE standards

Ordering codes

EPM 7000 Meter

PL7000	*	*	*	*	*	*	*	Description
								EPM 7000 Power Meter
Enclosure	XXXXXX ENC120 ENC277 ENN120 ENN277 ENS001 ENS002 ENS003 ENS004							None NEMA1 Rated - Indoor, Single Meter Enclosure, 120V NEMA1 Rated - Indoor, Single Meter Enclosure, 277V NEMA4X Rated - Indoor/Outdoor, Single Meter Enclosure, 120V NEMA4X Rated - Indoor/Outdoor, Single Meter Enclosure, 277V EPM Retrofit Panel Adapter - SWDGS5-E67-M EPM Retrofit Panel Adapter - SWDGL9-E67-M EPM Retrofit Panel Adapter - SWDGS9-E67-EPM EPM Retrofit Panel Adapter - SWDG435-SK-M
Frequency		6 5						60 Hz AC frequency system 50 Hz AC frequency system
Current Inputs			5A 1A					10 Amp Secondary 2 Amp Secondary
Software				A B C D E F				Multimeter Function Only Data Logging Memory Power Quality Harmonics Limits and Control 64 Samples/Cycle Waveform Recording 512 Samples/Cycle Waveform Recording
Power supply					HI LDC			90-265VAC/VDC 18-60VDC
I/O Slot 1						X E1 E2 C1 C20 RS1 PS1 F1 F2		None 100BaseT Ethernet 100BaseT Ethernet with IEC 61850 Protocol Four Channel Bi-directional 0-1mA Outputs Four Channel Bi-directional 4-20mA Outputs Two Relay status Outputs / Two Status Inputs Four Pulse Outputs / Four Status Inputs Fiber Optic Interface with ST Terminations Fiber Optic interface with Versatile Terminations
I/O Slot 2						X E1 E2 C1 C20 RS1 PS1 F1 F2		None 100BaseT Ethernet 100BaseT Ethernet with IEC 61850 Protocol Four Channel Bi-directional 0-1mA Outputs Four Channel Bi-directional 4-20mA Outputs Two Relay status Outputs / Two Status Inputs Four Pulse Outputs / Four Status Inputs Fiber Optic Interface with ST Terminations Fiber Optic interface with Versatile Terminations

Notes:

- Enclosures are not available when Power Supply LDC is selected
- Software option D, E, F required to add the RS1 relay features.

EPM 7000 Meter Accessories

GE Vernova Part number	Description
PL7000ACCE1X	100BaseT Ethernet
PL7000ACCE2X	61850 Communications card
PL7000ACCC1X	Four Channel Bi-directional 0-1mA Outputs
PL7000ACCC20	Four Channel 4-20mA Outputs
PL7000ACCRS1	Two Relay status Outputs / Two Status Inputs
PL7000ACCP1X	Four Pulse Outputs / Four Status Inputs
PL7000ACCF1X	Fiber Optic Interface with ST terminations
PL7000ACCF2X	Fiber Optic Interface with Versatile Terminations
PL7000ACCDIN	DIN Mounting Bracket

For more information
visit governova.com/grid-solutions

IEC is a registered trademark of Commission Electrotechnique Internationale. IEEE is a registered trademark of the Institute of Electrical Electronics Engineers, Inc. Modbus is a registered trademark of Schneider Automation. NERC is a registered trademark of North American Electric Reliability Council. NIST is a registered trademark of the National Institute of Standards and Technology.

GE, the GE monogram, Multilin, FlexLogic, EnerVista and CyberSentry are trademarks of General Electric Company.

GE Vernova reserves the right to make changes to specifications of products described at any time without notice and without obligation to notify any person of such changes.

© 2026 GE Vernova and/or its affiliates. All rights reserved. GE and the GE Monogram are trademarks of General Electric Company used under trademark license.



GE VERNOVA