

DT1-38

Dead Tank Circuit Breakers for 38 kV

One of the keys to safety in your substation is the circuit breaker. Safety can be ensured by using the DT1 circuit breaker, a product based on state-of-the-art technology and manufactured in modern production facilities.

A Rugged Performer

Due to its robust design, the DT1-38 is a highly reliable circuit breaker even under the most severe operating conditions and is tested to meet or exceed IEEE/ANSI and IEC standards, including the definite purpose applications.

Unique Performance

The DT1-38 is suitable for applications up to nameplate ratings, including definite purpose ratings and is uniquely qualified under the latest IEEE/ANSI and IEC standards as C2 class for capacitance switching including back-to-back (very low restrike probability) and reactor switching applications. Extensive mechanical operation design testing ensures trouble-free operation for the lifetime of the circuit breaker. Intensive production leak testing ensures superior in-service SF₆ performance.

Flexibility for New and Retrofit Applications

The compact DT1-38 design can be used in new or retrofit applications. The three-pole circuit breaker forms a complete, fully assembled, factory-tested, transportable unit. The on-site installation requires only a few simple steps. For installations where truck shipment is impossible, the DT1-38 can be readied for standard container shipment as a fully assembled unit.

Certified Quality

GE Vernova designs, manufactures, tests, and delivers its circuit breakers in accordance with IEEE/ANSI and IEC standards, maintaining a quality assurance system according to ISO-9001 and ISO-14001. The competence center for dead tank circuit breakers is located in Charleroi, PA (USA).

Installation and Maintenance

The DT1-38 is factory tested and adjusted. It does not need any special tools for installation. With a self-contained adjustable support structure, it is recognized worldwide as an easy-to-install circuit breaker. Due to the low-energy mechanism and lifetime lubricants, the DT series is virtually maintenance-free.



Main Characteristics

- Advanced self-blast interrupters
- Leak-resistant cast aluminum enclosures
- Durable low energy spring-operated mechanisms
- More than 100,000 circuit breakers with self-blast interrupters and FK spring-operated mechanisms in service since 1989

Key Benefits

- Proven reliability
- High performance
- ISO quality systems
- Near-zero maintenance
- Same interrupter and mechanism as DT1-72.5 with over 20 years of service experience and over 10,500 products in service worldwide



Dimensions

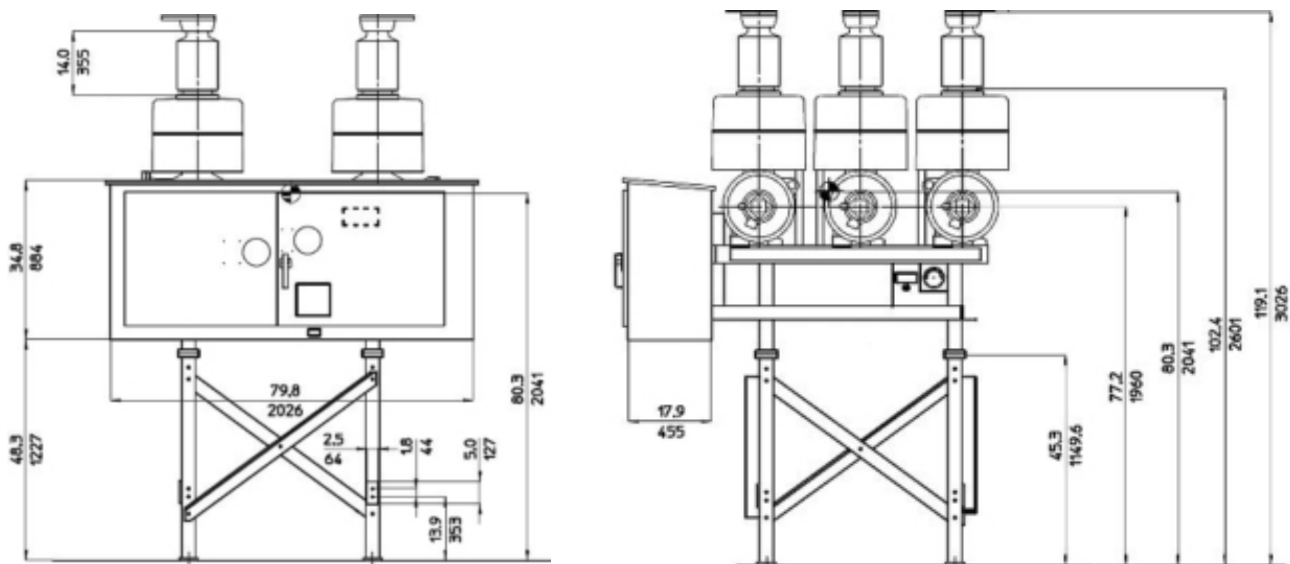

Technical Data

	VALUE	UNITS
SF ₆ pressure	67/0.46	psig/Mpa
Motor	1600	watts
Close coil/Trip coil	440/440	watts
Ambient temperature range*	-40 to +50	°C
Seismic capability	High Seismic per IEEE 693	
Weight (without current transformers)	2166/962	lb/kg
Weight SF ₆	26/12	lb/kb

Ratings

IEEE/ANSI	IEC	VALUE	UNITS
Rated maximum voltage	Rated voltage	38	kV
Rated power frequency	Rated frequency	50/60	Hz
Rated dielectric withstand capability: • dry withstand • wet withstand	Rated insulation level • at power frequency, dry • at power frequency, wet	80 75	kV kV
Rated lightning impulse withstand voltage	at lightning impulse	200*	kV
Rated chopped wave impulse voltage 2us/ /3us		258	kV
Rated continuous current	Rated normal current	1,200/2,000/3,000	A
Rated short-circuit current	Rated short-circuit breaking current	40	kA
Rated closing, latching and short time carrying current		104	kA
	Rated short-circuit making current	100	kA
Rated interrupting time		3	cycles
	Rated break time	50	ms
Rated standard operating duty	Rated operating sequence	O-CO-15s-CO O-0.3s-CO-180s-CO	

*Standard values: further data is available on request. **Please contact GE Vernova for special purpose, high TRV, high X/R or other ratings requirements.

Gas Data

The functioning of this equipment relies upon SF₆, a fluorinated greenhouse gas.

	SF ₆
Average mass of gas/mixture in the equipment (kg)*	8.1
GWP ₁₀₀ of gas/mixture (CO ₂ -equivalent)	24,300
CO ₂ -eq of gas/mixture in the equipment (t _{co2-eq})*	196.8

* For information purposes only. It varies depending on the equipment considered.

For more information, visit
governova.com/grid-solutions



© 2025 GE Vernova and/or its affiliates. All rights reserved. GE and the GE Monogram are trademarks of General Electric Company used under trademark license.

GEA-33320-(E)
English
250925