

Multilin™ L30

Cost-Effective Current Differential System for Lines and Cables

The Multilin L30 Line Differential System is a cost-effective line current differential protection relay intended for sub-transmission and medium voltage lines and cables, providing reliable and secure operation even under the worst-case power system conditions. The Multilin L30 provides secure high-speed fault detection and clearance suitable for three-pole tripping applications.

Part of the Universal Relay (UR) family, the Multilin L30 comes with a variety of versatile features truly integrating protection, monitoring, metering, communication and control in one easy-to-use device.

Key Benefits

- Proven current differential protection for secure, high-speed tripping
- Increased sensitivity through dynamic charging current compensation and communication channel asymmetry compensation
- Adaptive restraint characteristic provides security against measurement errors including CT saturation
- Embedded Synchrophasor measurement capabilities (per IEEE® C37.118), eliminating the need for dedicated PMUs and support for synchrophasor multi-cast (per IEC® 61850-90-5) reducing bandwidth and communications infrastructure costs
- Advanced IEC 61850 Ed. 2 implementation, complete settings via SCL files and IEC 61850-9-2 process bus solution enable resource and platform managing optimization and reduce cost of ownership
- CyberSentry™ provides high-end cyber security aligned to industry standards and services (NERC® CIP, AAA, Radius, RBAC, Syslog)
- Advanced fault and disturbance recording, including internal relay operating signals, eliminating the need for external recording devices

Applications

- Overhead lines and underground cables of different voltage levels
- Circuits with tapped transformer feeders
- Suitable for three-terminal lines, with channel redundancy and Direct Transfer Tripping (DTT)
- Wide area system monitoring and control using integrated protection and synchrophasor measurement
- Applications requiring three-pole autoreclosing and independent synchrocheck supervision



Protection & Control

- Line current differential with adaptive restraint, in-zone transformer & Stub bus protection
- Breaker failure and three-pole autoreclose
- Phase & negative sequence directional overcurrent, neutral directional with dual polarity criteria, broken conductor and thermal overload
- Phase over/under voltage, negative sequence overvoltage and 4 independent synchronism check elements

Advanced Communications

- 3 independent Ethernet ports with IEEE 1588 support
- Advanced IEC 61850 Edition 2 implementation and IEC 61850-9-2 process bus support
- Supported industry protocols: IEC 61850 Ed. 2, SFTP, MMS File Transfer Service, DNP 3.0, Modbus Serial/TCP, IEEE 1588, IEC 60870-5-104 and 103, PRP, SNTP, HTTP, TFTP
- Direct I/O for secure, high-speed exchange of data between Multilin L30s for DTT applications

Cyber Security

- CyberSentry™ provides high-end cyber security aligned to industry standards and services (NERC® CIP, AAA, Radius, RBAC, Syslog)

Monitoring & Metering

- Advanced recording capabilities with high-capacity event recorder, configurable and extended waveform capture and data logger
- P & M class synchrophasors of voltage, current, and sequence components



Protection and Control

The Multilin L30 offers a high degree of modularity in its design and functionality, providing superior performance while meeting the toughest requirements of the marketplace. Advanced protection and control features of this relay includes:

Current Differential Protection

The L30 current differential protection relay uses superior and patented algorithms to address the challenges of bandwidth, security, dependability and sensitivity in current differential relaying.

Bandwidth requirements are effectively addressed by means of a patented new data consolidation technique called "phaselets". This permits application within a communications bandwidth of 64 Kbps, and can detect faults within a half cycle plus channel delay.

L30 - Protection, Metering, Monitoring and Control

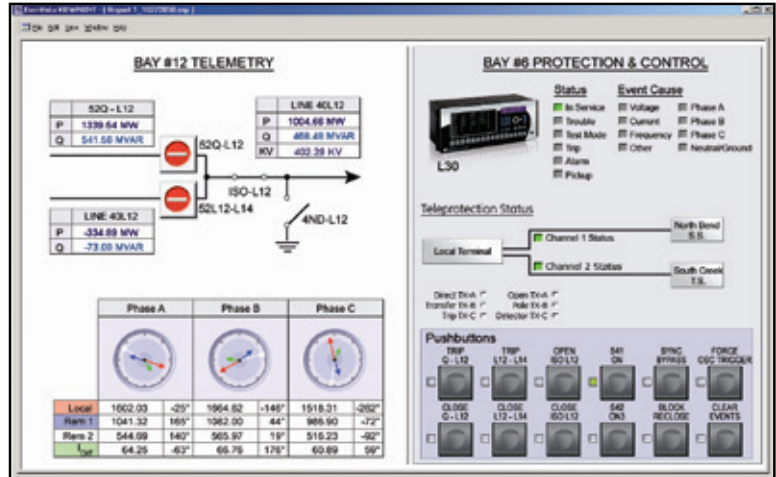

The L30 is the single point for protection, control, metering, and monitoring in one integrated device that can easily be connected directly into DCS or SCADA monitoring and control systems like Viewpoint Monitoring as shown.

Functional Block Diagram

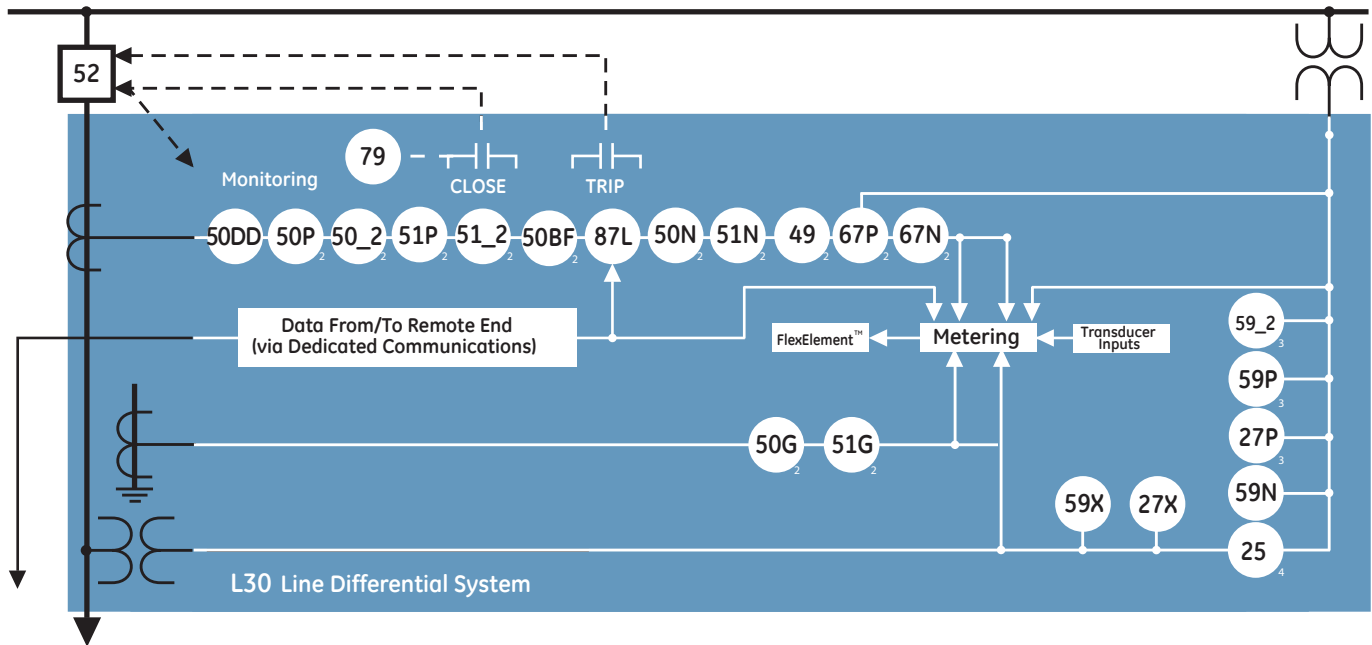

ANSI® Device Numbers & Functions

| DEVICE NUMBER | FUNCTION |
|---------------|----------------------------------|
| 25 | Synchronism Check |
| 27P | Phase Undervoltage |
| 27X | Auxiliary Undervoltage |
| 49 | Thermal Overload |
| 50BF | Breaker Failure |
| 50DD | Current Disturbance Detector |
| 50G | Ground Instantaneous Overcurrent |
| 59_2 | Negative Sequence Overvoltage |

| DEVICE NUMBER | FUNCTION |
|---------------|---|
| 50P | Phase Instantaneous Overcurrent |
| 50_2 | Negative Sequence Instantaneous Overcurrent |
| 51G | Ground Time Overcurrent |
| 51N | Neutral Time Overcurrent |
| 51P | Phase Time Overcurrent |
| 51_2 | Negative Sequence Time Overcurrent |
| 52 | AC Circuit Breaker |
| 59_2 | Negative Sequence Overvoltage |

| DEVICE NUMBER | FUNCTION |
|---------------|--------------------------------------|
| 59P | Phase Overvoltage |
| 59X | Auxiliary Overvoltage |
| 67N | Neutral Directional |
| 67P | Phase Directional |
| 79 | Automatic Recloser |
| 81U | Underfrequency |
| 87L | Segregated Line Current Differential |
| 87LG | Line Ground Current Differential |

The L30 innovative dual slope adaptive restraint characteristic, based on estimates of measurement errors, allows the relay to be secure on severe external faults while maintaining sensitivity for internal faults. The estimate of errors in the input currents permits more sensitive settings than those used in the traditional percent differential schemes. The line differential element also has 2nd harmonic inrush-current inhibit for in-zone power transformer protection. This functionality enables the L30 to protect 2 or 3-terminal lines that have a power transformer in between ends.

The L30 approach to clock synchronization relies upon precise distributed synchronization. Clocks are phase synchronized to each other and frequency synchronized to the power system frequency. Each relay compares its clock to the phase of the other clocks and makes appropriate adjustments. This allows for greater transient ride-through for power system and communications disturbances. Enhanced additional security is provided by a sensitive current disturbance detector, which can be used to supervise the current differential element.

Charging Current Compensation

For long lines and especially for underground cables, the charging current may be large and result in excessively high pickup settings. The L30 can dynamically compensate the charging current, thus increasing its sensitivity to the fault current on long transmission lines.

Enhanced Monitoring Features

The L30 uses advanced error detection and supervising functions to secure the L30 against maloperation due to erroneous data. High bit error rates are addressed by means of computing a 32-bit CRC checksum, effectively addressing the concerns of multiple bit errors due to high channel noise.

On multiplexed channels, channel asymmetry may be expected due to path switching causing spurious differential currents, which can endanger the security of the differential system. By using GPS time synchronization, up to 10ms of channel asymmetry can be compensated. Extra security has been implemented in the L30 to ensure proper operation in the event of IRIG-B signal failure.

Integrated channel monitoring provides real-time diagnostic data on the health of the L30. Communications channel deterioration or failure will activate an alarm, and can be used to enable backup protection. Channel propagation delay is monitored and adjusted according to variations in communication paths.

Communication Topologies

Relays can communicate through direct fiber, RS422, G.703, and IEEE C37.94 interfaces at 64Kbps, with extensive channel monitoring and diagnostics. In a current differential scheme, the L30s exchange data via the communication link, acting either as master collecting data, making calculations and making all relevant trip and restraint decisions, or as slave only, transmitting current data to the one acting as master. For two-terminal applications, use the redundant communications capability of the L30 for optimal reliability of the current differential line protection. For this scheme, data is continuously transmitted over both channels, so if a failure occurs, the L30 will continue to provide current differential protection.

For three-terminal applications, advanced inter-relay communication features eliminate the need for redundant communication channels due to the ability of the L30 to automatically switch between master and slave mode, maintaining a dependable system even with a failure of one of the communication channels.

Overvoltage and Undervoltage Protection

Long lines under lightly loaded or no-load conditions may experience voltages exceeding rated per unit voltage level of the line. Use the three phase overvoltage elements of the L30 to initiate a local trip as well as a remote trip using Direct Transfer Tripping (DTT).

Overcurrent Functions

The L30 provides thermal overload, and time and instantaneous overcurrent elements for phase, neutral, ground, negative sequence, phase and neutral directional. The neutral directional overcurrent element supports enhanced dual polarization modes which can be configured to prioritize on voltage or current polarization. Any of them can run in parallel with primary differential protection or can be programmed to run when the differential element is not available.

Direct Transfer Trip (DTT)

Use the DTT feature of L30 to trip remote breakers. Both single and three-pole DTTs are supported. Up to eight signals can be sent over pilot communications channels, selectable through user-configurable logic.

Autoreclosing

The L30 provides multi-shot autoreclosing for three-pole applications with independently programmable dead time for each shot. Autoreclose can be dynamically blocked by user-programmable logic.

Typical Applications

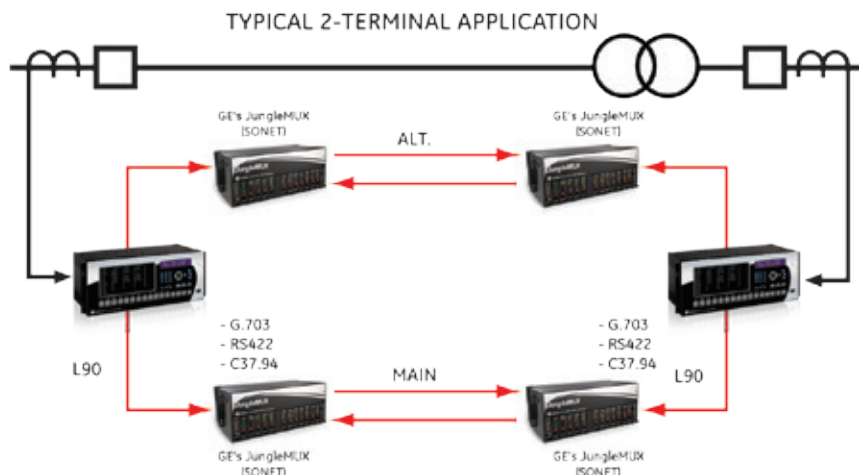

Typical two-terminal application of L30. L30 supports a variety of media cards for signaling between L30's including direct multimode or singlemode fiber, RS422, G.703 and IEEE C37.94.

FlexLogic Designer

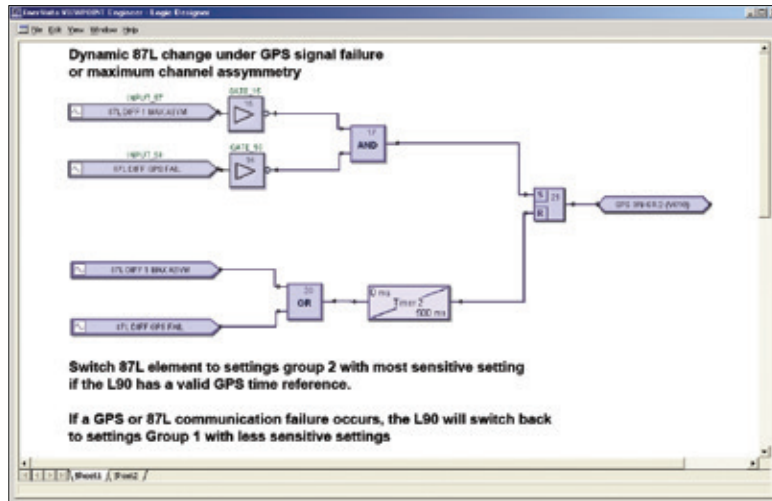

FlexLogic allows for the customization of the L30 to operate and control the breakers and other auxiliary devices needed to fit most line protection schemes and applications.

Synchronism Check

The L30 provides four synchrocheck elements that monitor voltage difference, phase angle difference and slip frequency to ensure proper breaker closure as per user requirements. The L30 provides additional enhancements in synchronizing, by checking dead source conditions for synchronism bypass under these conditions.

Breaker Failure

The L30 provides two fully independent breaker failure protection elements.

IEC 61850 Process Bus

The IEC 61850 Process Bus module is designed to interface with the GE Multilin HardFiber System, allowing bi-directional IEC 61850 fiber optic communications. The HardFiber System is designed to integrate seamlessly with existing UR applications, including protection functions, FlexLogic™, metering and communications.

The GE Multilin HardFiber System offers the following benefits:

- Communicates using open standard IEC 61850 messaging
- Drastically reduces P&C design, installation and testing labor by eliminating individual copper terminations
- Integrates with existing L30's by replacing traditional CT/VT inputs with the IEC 61850 Process Bus module
- Does not introduce new cyber security concerns

Visit the HardFiber System product page on the GE Multilin web site for more details.

Advanced Automation

The L30 incorporates advanced automation features including powerful FlexLogic programmable logic, communication, and SCADA capabilities that far surpass what is found in the average line relay. The L30 integrates seamlessly with other UR relays for complete system protection.

FlexLogic

FlexLogic is the powerful UR-platform programming logic engine that provides the ability to create customized protection and control schemes, minimizing the need and associated costs of, auxiliary components and wiring. Using FlexLogic, the L30 can be programmed to provide the required tripping logic along with custom scheme logic for line breaker control and interlocking and dynamic setting group changes.

Scalable Hardware

The L30 is available with a multitude of I/O configurations to suit the most demanding application needs. The expandable modular design allows for easy configuration and future upgrades.

- Flexible, modular I/O covering a broad range of input signals and tripping schemes
- Mechanically latching outputs can be used to develop secure interlocking applications and replace electromechanical lockout relays

Monitoring and Metering

The L30 includes high accuracy metering and recording for all AC signals. Voltage, current, and power metering are built into the relay as a standard feature. Current and voltage parameters are available as total RMS magnitude, and as fundamental frequency magnitude and angle.

Fault and Disturbance Recording

The advanced disturbance and event recording features within the L30 can significantly reduce the time needed for postmortem analysis of power system events and the creation of regulatory reports. Recording functions include:

- Sequence of Event (SOE)
 - 1024 time stamped events
- Oscillography
 - 64 digital & up to 40 analog channels
 - Events with up to 45s length
- Data Logger and Disturbance Recording
 - 16 channels up to 1 sample/cycle/channel
- Fault Reports
 - Powerful summary report of pre-fault and fault values

The very high sampling rate and large amount of storage space available for data recording in the L30 can eliminate the need for installing costly stand-alone recording equipment.

Advanced Device Health Diagnostics

The L30 performs comprehensive device health diagnostic tests at startup and continuously during run-time to test its own major functions and critical hardware. These diagnostic tests monitor for conditions that could impact security and availability of protection, and present device status via SCADA communications and front panel display. Providing continuous monitoring and early detection of possible issues help improve system uptime.

- Comprehensive device health diagnostic performed at startup
- Monitors the CT/VT input circuitry to validate the integrity of all signals

Cyber Security – CyberSentry UR

CyberSentry UR enabled UR devices deliver full cyber security features that help customers to comply with NERC CIP and NIST® IR 7628 cyber security requirements.

This software option delivers the following core features:

AAA Server Support (Radius/LDAP)

Enables integration with centrally managed authentication and accounting of all user activities and uses modern industry best practices and standards that meet and exceed NERC CIP requirements for authentication and password management.

Role Based Access Control (RBAC)

Efficiently administrate users and roles within UR devices. The new and advanced access functions allow users to configure up to five roles for up to eight configurable users with independent passwords. The standard "Remote Authentication Dial In User Service" (Radius) is used for authentication.

Event Recorder (Syslog for SEM)

Capture all cyber security related events within a SOE element (login, logout, invalid password attempts, remote/local access, user in session, settings change, FW update, etc), and then serve and classify data by security level using standard Syslog data format. This will enable integration with established SEM (Security Event Management) systems.

Communications

The L30 provides for secure remote data and engineering access, making it easy and flexible to use and integrate into new and existing

infrastructures. Fiber optic Ethernet provides high-bandwidth communications allowing for low-latency controls and high-speed file transfers of relay fault and event record information. The available three independent Ethernet ports, redundant Ethernet option and the embedded managed Ethernet switch provide the means to create fault tolerant communication architectures in an easy, cost-effective manner. The L30 supports the most popular industry standard protocols enabling easy, direct integration into monitoring and SCADA systems.

- IEC 61850 Ed. 2 with 61850-9-2 and 61850-90-5 support
- DNP 3.0 (serial & TCP/IP)
- Ethernet Global Data (EGD)
- IEC 60870-5-103 and IEC 60870-5-104
- Modbus RTU, Modbus TCP/IP
- HTTP, TFTP, SFTP and MMS file transfer
- SNTP and IEEE 1588 for time synchronization
- PRP as per IEC 62439-3

Interoperability with Embedded IEC 61850 Edition 2

The new IEC 61850 implementation in the UR Family positions GE as an industry leader in this standard.

- Implements Edition 2 of the standard across the entire family of UR devices

- Provides full relay setting management via standard SCL files (ICD, CID and IID)
- Enables automated relay setting management using 3rd party tools through standard file transfer services (MMS and SFTP)
- Increases the number of Logical Devices and data mapped to them, GOOSE messages, and reports to support different organizational needs for data transfer and reduce dependency on generic logical nodes
- Configures GE Systems based on IEC 61850 using universal 3rd party tools
- Multicast IEEE C37.118 synchrophasor data between PMU and PDC devices using IEC 91850-90-5

LAN Redundancy

Substation LAN redundancy has been traditionally accomplished by reconfiguring the active network topology in case of failure. Regardless of the type of LAN architecture (tree, mesh, etc), reconfiguring the active LAN requires time to switchover, during which the LAN is unavailable. UR devices deliver redundancy as specified by PRP-IEC 62439-3, which eliminates the dependency on LAN reconfiguration and the associated switchover time. The UR becomes a dual attached node that transmits data packets over both main and redundant networks simultaneously, so in case of failure, one of the data packets will reach the receiving device with no time delay.

Power System Troubleshooting

The L30 contains many tools and reports that simplify and reduce the amount of time required for troubleshooting power system events.

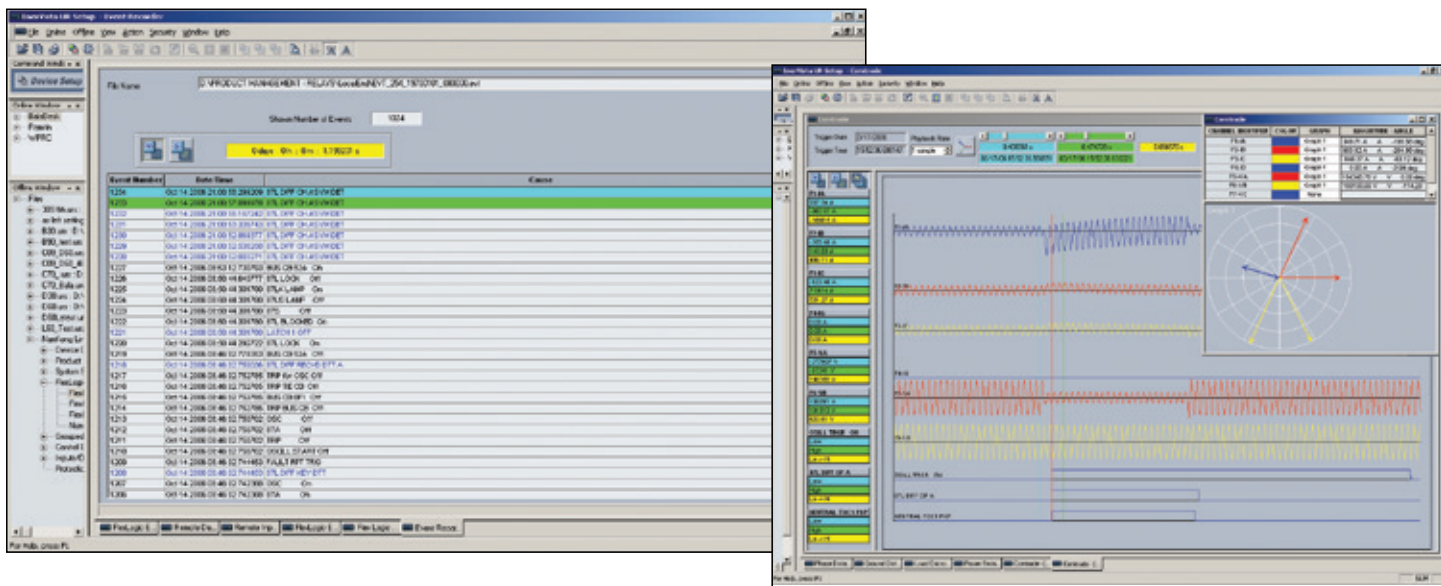

Record the operation of the internal L30 elements and external connected devices with 1ms time-stamped accuracy to identify the Sequence of Operation of station devices during line faults and disturbances.

Analyze line faults using both analog and digital power system quantities that are measured and recorded up to a rate of 64 samples per cycle.

Multi-Language

UR devices support multiple languages: English, French, Russian, Chinese, Turkish and German. These language options are available on the front panel, in the EnerVista setup software, and in the product manuals. Easily switch between English and an additional language on the local displays without uploading new firmware.

EnerVista Software

The EnerVista suite is an industry-leading set of software programs that simplifies every aspect of using the L30 relay. The EnerVista suite provides all the tools to monitor the status of the protected asset, maintain the relay, and integrate information measured by the L30 into DCS or SCADA monitoring systems. Convenient COMTRADE and SOE viewers are an integral part of the UR setup software included with every UR relay, to carry out postmortem event analysis and ensure proper protection system operation.

EnerVista Launchpad

EnerVista Launchpad is a powerful software package that provides users with all of the setup and support tools needed for configuring and maintaining GE Multilin products. The setup software within Launchpad allows for the configuration of devices in real-time by communicating using serial, Ethernet, or modem connections, or offline by creating setting files to be sent to devices at a later time.

Included in Launchpad is a document archiving and management system that ensures critical documentation is up-to-date and available when needed. Documents made available include:

- Manuals
- Application Notes
- Guideform Specifications
- Brochures
- Wiring Diagrams
- FAQ's
- Service Bulletins

Viewpoint Monitoring

Viewpoint Monitoring is a simple-to-use and full-featured monitoring and data recording software package for small systems. Viewpoint Monitoring provides a complete HMI package with the following functionality:

- Plug-&-Play Device Monitoring
- System Single-Line Monitoring & Control
- Annunciator Alarm Screens
- Trending Reports
- Automatic Event Retrieval
- Automatic Waveform Retrieval

Viewpoint UR Engineer

Viewpoint UR Engineer is a set of powerful tools that allows the configuration and testing of GE relays at a system level in an easy-to-use graphical drag-and-drop environment. Viewpoint UR Engineer provides the following configuration and commissioning utilities:

- Graphical Logic Designer
- Graphical System Designer
- Graphical Logic Monitor
- Graphical System Monitor

Viewpoint Maintenance

Viewpoint Maintenance provides tools that will create reports on the operating status of the relay, simplify the steps to download fault and event data, and reduce the work required for cyber security compliance audits. Tools available in Viewpoint Maintenance include:

- Settings Security Audit Report
- Device Health Report
- Single-Click Fault Data Retrieval

EnerVista Integrator

EnerVista Integrator is a toolkit that allows seamless integration of GE Multilin devices into new or existing automation systems. Included in EnerVista Integrator is:

- OPC/DDE Server
- GE Multilin Drivers
- Automatic Event Retrieval
- Automatic Waveform Retrieval

User Interface

The L30 front panel provides extensive local HMI capabilities. The local display is used for monitoring, status messaging, fault diagnosis, and device configuration. User-configurable messages that combine text with live data, can be displayed when user-defined conditions are met.

48 Configurable LED Indicators



Multi-Language Display

- English
- Russian
- French
- Chinese
- Turkish
- German

Typical Wiring

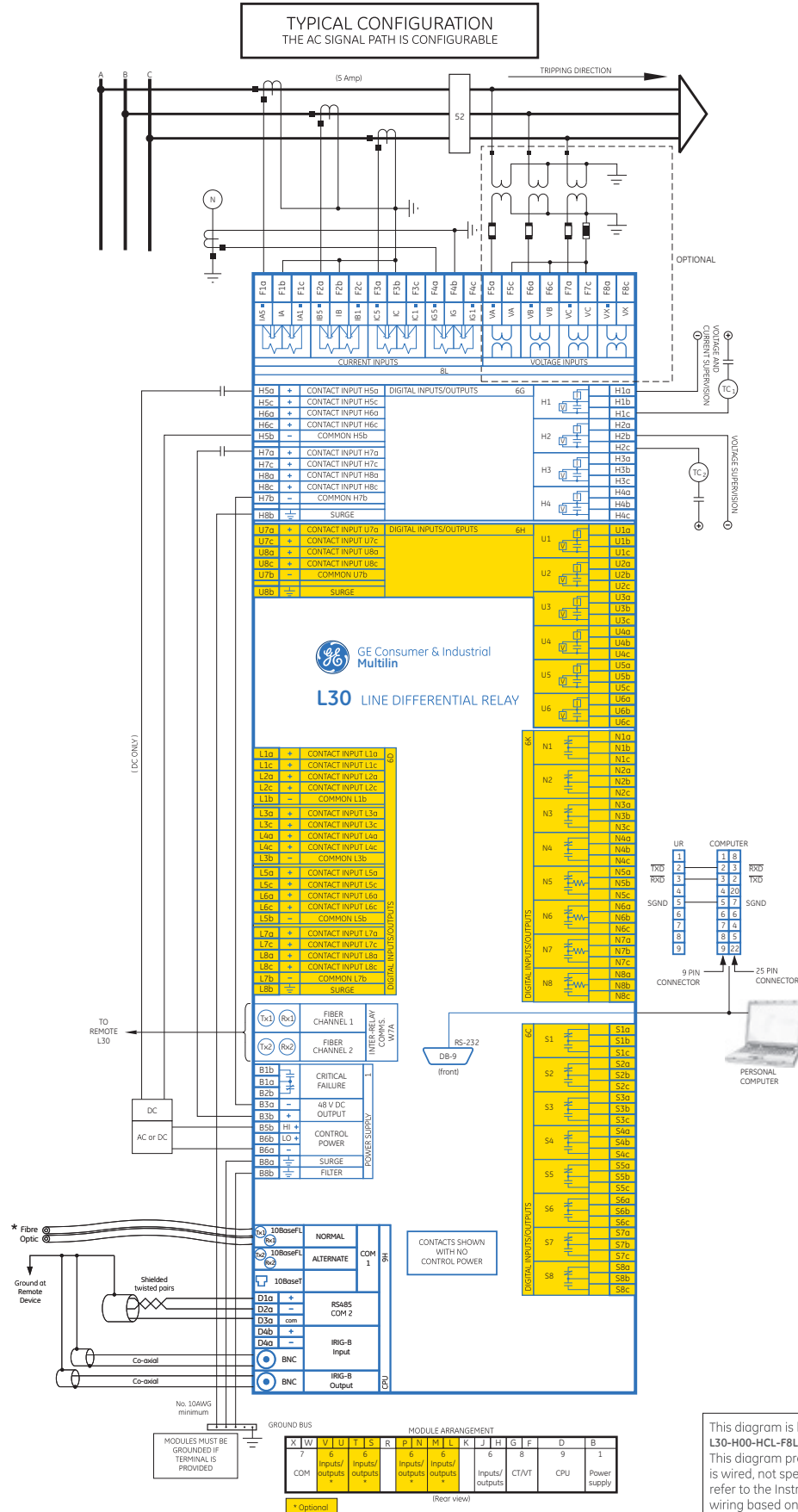

This diagram is based on the following order code:
L30-H00-HCL-F8L-H6G-L6D-N6K-S6C-U6H-W7A
This diagram provides an example of how the device is wired, not specifically how to wire the device. Please refer to the Instruction Manual for additional details on wiring based on various configurations.

Ordering

| | L30 | - | * | 00 | -H | * | -F | ** | -H | ** | -L | ** | -N | ** | -S | ** | -U | ** | -W/X | ** | ** | For Full Sized Horizontal Mount |
|--|-----|---|---|----|---|---|----------------|----|----|----|----|----|----|----|----|----|----|----|------|----|----|--|
| Base Unit | L30 | | | | | | | | | | | | | | | | | | | | | Base Unit |
| CPU | | | | | | | | | | | | | | | | | | | | | | RS485 + RS485 (IEC 61850 option not available) RS485 + multimode ST 100BaseFX RS485 + multimode ST Redundant 100BaseFX RS485 + 10/100 BaseT RS485 + three multimode SFP LC 100BaseFX. Req FW v7xx or higher RS485 + two multimode SFP LC 100BaseFX + one SFP RJ45 100BaseT. Req FW v7xx or higher RS485 + three SFP RJ45 100BaseT. Req FW v7xx or higher No Software Options |
| Software Options (see note 1 below) | | | | 00 | | | | | | | | | | | | | | | | | | IEC 61850 Phasor Measurement Unit (PMU) IEC 61850 + Phasor Measurement Unit (PMU) 3P Autoreclose and Synchrocheck 3P Autoreclose, Synchrocheck, IEC 61850 and Phase Measurement Unit (PMU) In-zone TX protection In-zone TX protection + IEC 61850 In-zone TX protection + PMU In-zone TX protection + IEC 61850 + PMU CyberSentry UR Lvl 1. Req UR FW 7.xx or higher IEEE 1588. Req UR FW 7.xx or higher PRP IEEE 1588 + CyberSentry. Req UR FW 7.xx or higher IEC 61850 + PMU + 61850-90-5 |
| Mount / Coating | | | | | H | | | | | | | | | | | | | | | | | Horizontal (19" rack) - Standard Horizontal (19" rack) - Harsh Environment Coating Vertical (3/4 size) - Standard Vertical (3/4 size) - Harsh Environment Coating |
| User Interface | | | | | A | | | | | | | | | | | | | | | | | Chinese English French Russian Chinese with Additional 4 Small and 12 Large Programmable Pushbuttons English with Additional 4 Small and 12 Large Programmable Pushbuttons French with Additional 4 Small and 12 Large Programmable Pushbuttons Russian with Additional 4 Small and 12 Large Programmable Pushbuttons Enhanced Chinese Front Panel Enhanced Chinese Front Panel with User-Programmable Pushbuttons Enhanced English Front Panel Enhanced English Front Panel with User-Programmable Pushbuttons Enhanced French Front Panel Enhanced French Front Panel with User-Programmable Pushbuttons Enhanced German Front Panel Enhanced German Front Panel with User-Programmable Pushbuttons Enhanced Russian Front Panel Enhanced Russian Front Panel with User-Programmable Pushbuttons Enhanced Turkish Front Panel Enhanced Turkish Front Panel with User-Programmable Pushbuttons |
| NOTE: These selections are only for horizontal units | | | | | C D R B P G S U V K L M N I J Q T W Y | | | | | | | | | | | | | | | | | |
| Power Supply (see note 2 below) | | | | | H | | | | | | | | | | | | | | | | | 125 / 250 V AC/DC 125/250 V AC/DC with redundant 125/250 V AC/DC 24 - 48 V (DC only) Standard 4CT/4VT Standard 8CT Standard 4CT/4VT with enhanced diagnostics Standard 8CT with enhanced diagnostics 8 Port IEC 61850 Process Bus Module |
| CT/VT DSP | | | | | L | | 8F | | | | | | | | | | | | | | | No Module 4 Solid State (No Monitoring) MOSFET Outputs 4 Solid State (Current w/opt Voltage) MOSFET Outputs 16 Digital Inputs with Auto-Burnish 14 Form-A (No Monitoring) Latching Outputs 8 Form-A (No Monitoring) Outputs 8 Form-C Outputs 16 Digital Inputs 4 Form-C Outputs, 8 Digital Inputs 8 Fast Form-C Outputs 4 Form-C & 4 Fast Form-C Outputs 2 Form-A (Current w/ opt Voltage) & 2 Form-C Outputs, 8 Digital Inputs 2 Form-A (Current w/ opt Voltage) & 4 Form-C Outputs, 4 Digital Inputs 4 Form-A (Current w/ opt Voltage) Outputs, 8 Digital Inputs 6 Form-A (Current w/ opt Voltage) Outputs, 4 Digital Inputs 2 Form-A (No Monitoring) & 2 Form-C Outputs, 8 Digital Inputs 2 Form-A (No Monitoring) & 4 Form-C Outputs, 4 Digital Inputs 4 Form-A (No Monitoring) Outputs, 8 Digital Inputs 6 Form-A (No Monitoring) Outputs, 4 Digital Inputs 2 Form-A (Cur w/ opt Volt) 1 Form-C Output, 2 Latching Outputs, 8 Digital Inputs |
| IEC 61850 Process Bus Digital I/O | | | | | | | 8H 8L 8N | | 81 | | XX | XX | XX | XX | XX | | | | | | | 4 dcmA Inputs, 4 dcmA Outputs 8 RTD Inputs 4 RTD Inputs, 4 dcmA Outputs 4 dcmA Inputs, 4 RTD Inputs 8 dcmA Inputs |
| Transducer I/O Select a maximum of 3 | | | | | | | | | 5A | 5A | 5A | 5A | 5A | 5A | | | | | | | | 2A 2A C37.94SM, 1300nm singlemode, ELED, 1 Channel singlemode 2B 2B C37.94SM, 1300nm singlemode, ELED, 2 Channel singlemode 2I 2I Channel 1 - IEEE C37.94, 820nm, multimode fiber, 64/128 kbps; Channel 2 - 1300 nm, singlemode, LASER 2J 2J Channel 1 - IEEE C37.94, 820nm, multimode fiber, 64/128 kbps; Channel 2 - 1550 nm, singlemode, LASER 7A 7A 820 nm, multimode, LED, 1 Channel 7B 7B 1300 nm, multimode, LED, 1 Channel 7H 7H 820 nm, multimode, LED, 2 Channels 7I 7I 1300 nm, multimode, LED, 2 Channels 7R 7R G.703, 1 Channel 7S 7S G.703, 2 Channels 7T 7T RS422, 1 Channel 7W 7W RS422, 2 Channels 72 72 1550 nm, singlemode, LASER, 1 Channel 73 73 1550 nm, singlemode, LASER, 2 Channels 76 76 IEEE C37.94, 820 nm, multimode, LED, 1 Channel 77 77 IEEE C37.94, 820 nm, multimode, LED, 2 Channel |
| Inter-Relay Communications Select a maximum of 1 | | | | | | | | | 5C | 5C | 5C | 5C | 5C | 5C | | | | | | | | |

Ordering Note:

1. To view all the options available for L30, please visit GE's On-Line Store <http://store.gedigitalenergy.com/viewprod.asp?model=L30>
2. Redundant power supply only available in horizontal unit. If redundant chosen, must be same type. Maximum 2 per chassis.

IEC is a registered trademark of Commission Electrotechnique Internationale. IEEE is a registered trademark of the Institute of Electrical Electronics Engineers, Inc. Modbus is a registered trademark of Schneider Automation. NERC is a registered trademark of North American Electric Reliability Council. NIST is a registered trademark of the National Institute of Standards and Technology.



GE, the GE monogram, Multilin, FlexLogic, EnerVista and CyberSentry are trademarks of General Electric Company. GE reserves the right to make changes to specifications of products described at any time without notice and without obligation to notify any person of such changes.

Copyright 2015, General Electric Company. All Rights Reserved.

GEA-12759(IE)
English
150203