



# MVTP

## Buswire Supervision for High Impedance Schemes

The MVTP is a monitoring device, used to ensure the integrity of busbar, and restricted earth fault schemes.

The MVTP relay is available in two types:

- Type MVTP 11 - single phase relay
- Type MVTP 31 - three phase relay

These provide continuous supervision of the buswires in high impedance type busbar protection schemes, detecting open-circuited buswires as well as open-circuited main current transformers.

In earth-fault only protection schemes, the single-phase relay is employed.

MVTP relays have a setting range of 1-16 V, adjusted by means of DIL switches on the relay front panel. Relays are continuously rated at 600 V rms and no external components are required.

The AC voltage input is continuously monitored and when it exceeds the level pre-set by means of the plug setting, the output relay is actuated after a three or ten second delay.

The hand reset contacts of the output relay are normally connected across the buswires of the busbar protection thus short-circuiting the busbar protection relay and rendering the protection of the zone concerned inoperative.

On the same output relay are hand reset contacts for alarm purposes.

Operation of the relay is indicated by a hand resettable mechanical flag.

## Key Benefits

- Integral buswire shorting facility
- Low AC burden
- No external resistors required
- Ensures the availability of MCAG and MFAC schemes



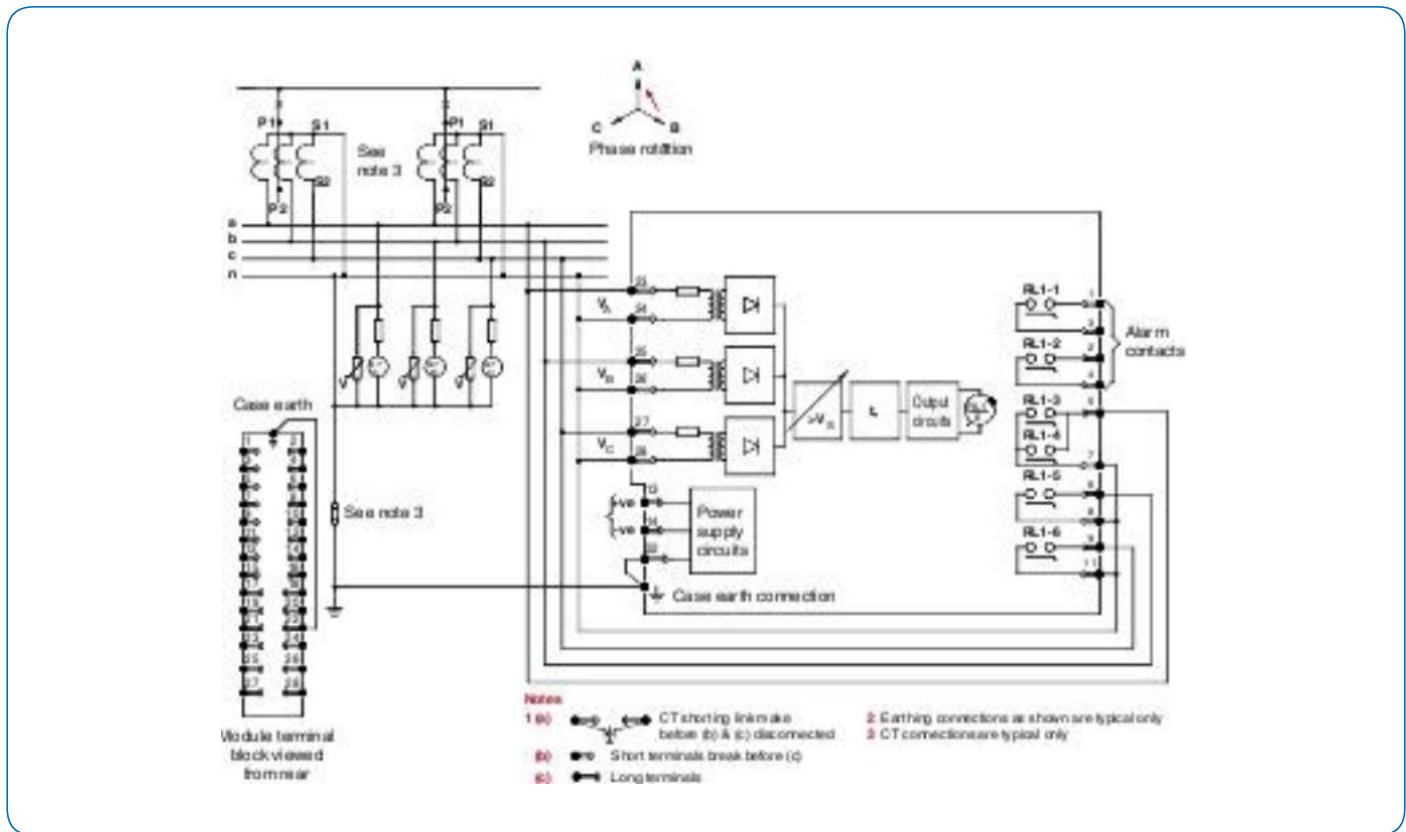

Figure 1 Application diagram: buswire voltage supervision relay, type MVTP31

### Technical Data

- Burdens
- Measuring circuit - typical burdens
- Settings
- Setting range (VS) 1-16 V rms adjusted by means of DIL switches in 1 V steps

<b>Applied Voltage VAC</b>	2	8	14	600
<b>Burden VA</b>	$0.04 \times 10^{-3}$	$0.7 \times 10^{-3}$	$2.2 \times 10^{-3}$	4.0

- Auxiliary supply - typical burdens at the upper rated voltage

Vx Rated Voltage (V dc)	Output Relay not Energised		Output Relay Energised	
	mA	W	mA	W
30/34	24	0.82	90	3.06
48/54	24	1.3	90	4.86
110/125	24	3.0	35	4.37
220/250	24	6.0	35	8.75

## Auxiliary Supplies (Vx)

Ratings (VDC)	Operative Range (VDC)
24/27*	19.2-30.2
30/34	24-37.5
48/54	37.5-60
110/125	87.5-137.5
220/250	175 -275

\* Use a 30/34 V relay with a separate MSTZ 02 DC/DC converter

	Make and Continuous LY Carry	Make and Carry for 3 Seconds	Break
AC	1250 VA with maxima of 5 Amps and 600 V	7500 VA with maxima of 30 Amps and 600 V	1250 VA with maxima of 5 Amps and 600 V
DC	1250 W with maxima of 5 Amps and 600 V	7500 W with maxima of 30 Amps and 600 V	100 W (resistive) and 50 W (inductive) and maxima of 5 Amps and 600 V

The hand-reset contacts will carry 150 Arms for 0.5 seconds.



Type MVTP relay withdrawn from case

All relays are rated continuously at the maximum voltage in the operative range.

- Frequency 50 and 60 Hz
- Operative range 47-61 Hz
- Operating time Fixed at 3 or 10 seconds
- Contact disengaging time 150 ms
- Drop off/pick up ratio
  - > 85% after 3 second delay
  - > 98% before 3 second delay

### Thermal Rating

- Continuous 600 Vrms per phase on all three phases simultaneously (at any setting)
- Short time The relay will withstand 2 kVrms per phase, for 3seconds on all three phases simultaneously (at any setting)

### Contacts

Buswire shorting contacts are normally open type. The two alarm contacts may be specified in any combination of make or break (2M, 1M 1B, or 2B)

Self monitoring for high impedance unit protection, for peace of mind

## Cases

Types MVTP 11 and MVTP 31 are supplied in size 4 and size 6 cases respectively, as shown in Figures 2 and 3.

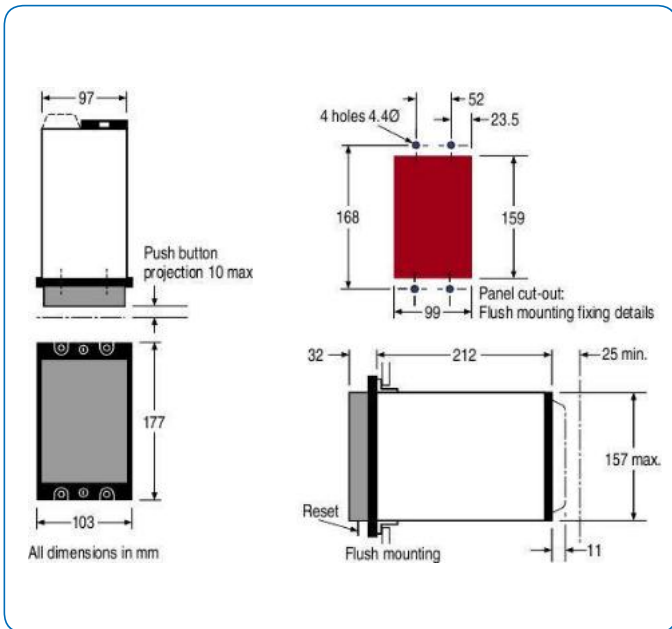

Figure 2 MVTP 11. Case outline size 4

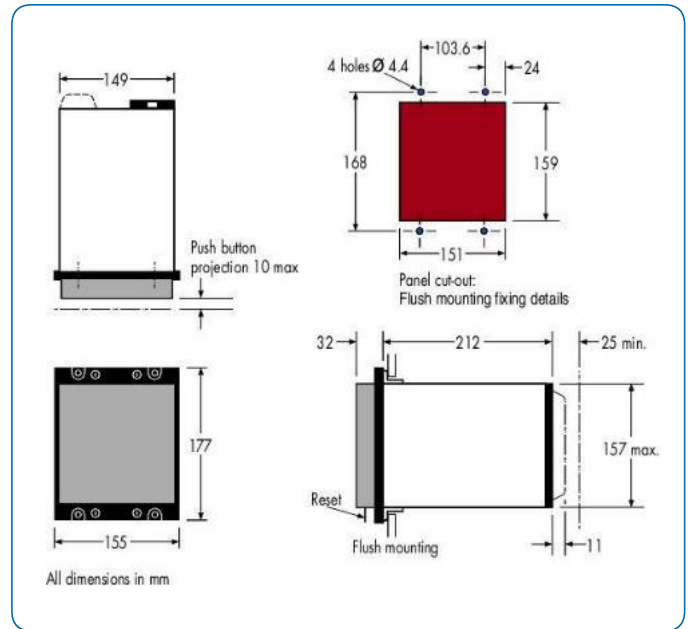

Figure 3 MVTP 31. Case outline size 6

## Track Record - Auxiliary Relays

Over 200,000 MVAJ tripping relays delivered since launching in 1983

Over 150,000 MVAA auxiliary relays delivered since launching in 1983

Over 350,00 PRiMA auxiliaries delivered since launching in 1994

Nearly 300,00 MVAX relays delivered since 1983

## Information Required with your Order

- Relay type
- DC auxiliary voltage
- Configuration of alarm contacts
- Time delay 3 seconds or 10 seconds

For more information please contact  
GE  
Grid Solutions

### Worldwide Contact Center

Web: [www.GEGridSolutions.com/contact](http://www.GEGridSolutions.com/contact)  
Phone: +44 (0) 1785 250 070

## GEGridSolutions.com

IEC is a registered trademark of Commission Electrotechnique Internationale. IEEE is a registered trademark of the Institute of Electrical Engineers, Inc.

GE and the GE monogram are trademarks of General Electric Company.

GE reserves the right to make changes to specifications of products described at any time without notice and without obligation to notify any person of such changes.

MVTP-Brochure-EN-2018-11-Grid-GA-0729. © Copyright 2018, General Electric Company. All rights reserved.