

GE Vernova
Grid Solutions

iSTAT I400

Standard Transducer

Manual

Publication reference: I400/EN/M/F



GE VERNOVA

HANDLING OF ELECTRONIC EQUIPMENT

A person's normal movements can easily generate electrostatic potentials of several thousand volts. Discharge of these voltages into semiconductor devices when handling circuits can cause serious damage, which often may not be immediately apparent but the reliability of the circuit will have been reduced.

The electronic circuits of GE Vernova products are immune to the relevant levels of electrostatic discharge when housed in their cases. Do not expose them to the risk of damage by withdrawing modules unnecessarily.

Each module incorporates the highest practicable protection for its semiconductor devices. However, if it becomes necessary to withdraw a module, the following precautions should be taken to preserve the high reliability and long life for which the equipment has been designed and manufactured.

1. Before removing a module, ensure that you are at the same electrostatic potential as the equipment by touching the case.
2. Handle the module by its front-plate, frame, or edges of the printed circuit board. Avoid touching the electronic components, printed circuit track or connectors.
3. Do not pass the module to any person without first ensuring that you are both at the same electrostatic potential. Shaking hands achieves equipotential.
4. Place the module on an anti-static surface, or on a conducting surface that is at the same potential as you.
5. Store or transport the module in a conductive bag.

More information on safe working procedures for all electronic equipment can be found in BS5783 and IEC 60147-0F.

If you are making measurements on the internal electronic circuitry of equipment in service, it is preferable that you are earthed to the case with a conductive wrist strap.

Wrist straps should have a resistance to ground between 500k – 10M ohms. If a wrist strap is not available you should maintain regular contact with the case to prevent the build up of static. Instrumentation which may be used for making measurements should be earthed to the case whenever possible.

GE Vernova strongly recommends that detailed investigations on the electronic circuitry, or modification work, be carried out in a Special Handling Area such as described in BS5783 or IEC 60147-0F.

1. SAFETY SECTION





This Safety Section should be read before commencing any work on the equipment.

1.1 Health and Safety

The information in the Safety Section of the product documentation is intended to ensure that products are properly installed and handled in order to maintain them in a safe condition. It is assumed that everyone who will be associated with the equipment will be familiar with the contents of the Safety Section.

1.2 Explanation of symbols and labels

The meaning of symbols and labels may be used on the equipment or in the product documentation, is given below.

	
Caution: refer to product documentation	Caution: risk of electric shock
	
Protective/safety *earth terminal	Functional *earth terminal Note: This symbol may also be used for a protective/safety earth terminal if that terminal is part of a terminal block or sub-assembly e.g. power supply.

*NOTE: The term earth used throughout the product documentation is the direct equivalent of the North American term ground.

2. INSTALLING, COMMISSIONING AND SERVICING



Equipment connections

Personnel undertaking installation, commissioning or servicing work on this equipment should be aware of the correct working procedures to ensure safety. The product documentation should be consulted before installing, commissioning or servicing the equipment.

Terminals exposed during installation, commissioning and maintenance may present a hazardous voltage unless the equipment is electrically isolated.

If there is unlocked access to the rear of the equipment, care should be taken by all personnel to avoid electrical shock or energy hazards.

Voltage and current connections should be made using insulated crimp terminations to ensure that terminal block insulation requirements are maintained for safety. To ensure that wires are correctly terminated the correct crimp terminal and tool for the wire size should be used.

Before energising the equipment it must be earthed using the protective earth terminal, or the appropriate termination of the supply plug in the case of plug connected equipment. Omitting or disconnecting the equipment earth may cause a safety hazard.

The recommended minimum earth wire size is 2.5mm², unless otherwise stated in the technical data section of the product documentation.

Before energising the equipment, the following should be checked:

- Voltage rating, frequency and polarity
- VT ratio and phase sequence
- CT circuit rating and integrity of connections;
- Protective fuse rating;
- Integrity of earth connection (where applicable)
- Supply voltage

3. EQUIPMENT OPERATING CONDITIONS

The equipment should be operated within the specified electrical and environmental limits.

3.1 Current transformer circuits



Do not open the secondary circuit of a live CT since the high level voltage produced may be lethal to personnel and could damage insulation.

3.2 External resistors



Where external resistors are fitted to relays, these may present a risk of electric shock or burns, if touched.

3.3 Battery Replacement



Where internal batteries are fitted they should be replaced with the recommended type and be installed with the correct polarity, to avoid possible damage to the equipment.

3.4 Insulation and dielectric strength testing



Insulation testing may leave capacitors charged up to a hazardous voltage. At the end of each part of the test, the voltage should be gradually reduced to zero, to discharge capacitors, before the test leads are disconnected.

3.5 Insertion of modules and pcb cards



These must not be inserted into or withdrawn from equipment whilst it is energised since this may result in damage.

3.6 Fibre optic communication



Where fibre optic communication devices are fitted, these should not be viewed directly. Optical power meters should be used to determine the operation or signal level of the device.

4. OLDER PRODUCTS

Electrical adjustments



Equipment's that require direct physical adjustments to their operating mechanism to change current or voltage settings should have the electrical power removed before making the change, to avoid any risk of electrical shock.

Mechanical adjustments



The electrical power to the relay contacts should be removed before checking any mechanical settings, to avoid any risk of electric shock.

Draw out case relays



Removal of the cover on equipment incorporating electromechanical operating elements, may expose hazardous live parts such as relay contacts.

Insertion and withdrawal of extender cards



When using an extender card, this should not be inserted or withdrawn from the equipment whilst it is energised. This is to avoid possible shock or damage hazards. Hazardous live voltages may be accessible on the extender card.

Insertion and withdrawal of heavy current test plugs



When using a heavy current test plug, CT shorting links must be in place before insertion or removal, to avoid potentially lethal voltages.

5. DECOMMISSIONING AND DISPOSAL



Decommissioning: The auxiliary supply circuit in the relay may include capacitors across the supply or to earth. To avoid electric shock or energy hazards, after completely isolating the supplies to the relay (both poles of any dc supply), the capacitors should be safely discharged via the external terminals prior to decommissioning.

Disposal: It is recommended that incineration and disposal to water courses is avoided. The product should be disposed of in a safe manner. Any products containing batteries should have them removed before disposal, taking precautions to avoid short circuits. Particular regulations within the country of operation, may apply to the disposal of lithium batteries.

6. TECHNICAL SPECIFICATIONS

6.1 Protective fuse rating

The recommended maximum rating of the external protective fuse for this equipment is 16A, Red Spot type or equivalent, unless otherwise stated in the technical data section of the product documentation.

Insulation class:	IEC 61010-1 : 2002 Class II EN 61010-1 : 2002 Class II	
Insulation Category (Over voltage):	IEC 61010-1 : 2002 Category II (600V), III (300V) EN 61010-1 : 2002 Category II (600V), III (300V)	
Environment:	IEC 61010-1 : 2002 Pollution degree 2 (600V), 3 (300V) EN 61010-1 : 2002 Pollution degree 2 (600V), 3 (300V)	Compliance is demonstrated by reference to generic safety standards.
Product Safety: 	2006/95/EC EN 61010-1 : 2002	Compliance with the European Commission Low Voltage Directive. Compliance is demonstrated by reference to generic safety standards.

8.4.1	Output Ranges	17
8.4.2	Accuracy	17
8.5	Analogue Output Ratings – D.C. transducers	18
8.5.1	Output Ranges	18
8.5.2	Accuracy	18
8.6	Pulsed energy switches (I4E)	18
8.6.1	Output range	18
8.6.2	Accuracy	18
8.7	Communication ports	18
8.7.1	EIA232 Port	18
8.7.2	EIA485 Port	19
8.8	Electrical Environment	19
8.9	Environmental Conditions	19
8.9.1	Atmospheric environment	19
8.9.2	Construction	20
9.	INSTALLATION	21
9.1	Dimensions	21
9.2	Mounting	21
9.3	Internal Jumpers	22
10.	CONNECTIONS	23
10.1	Auxiliary Supply Connection	23
10.1.1	A.C. auxiliary supply	23
10.1.2	Universal auxiliary supply	23
10.2	Communications Connections	23
10.2.1	EIA232 port	23
10.2.2	EIA485 port	24
10.3	Input Connections	24
10.3.1	A.C. input transducers	24
10.3.2	D.C. input transducers	25
10.4	Output Connections	26
11.	RELATED DOCUMENTS	27
12.	MODBUS IMPLEMENTATION	28
12.1	TRANSACTIONS	28
12.1.1	Request	28
12.1.2	Response	28
12.1.3	Example of Request - Response cycle	28
12.2	FRAMING	29
12.2.1	RTU framing	29
12.3	SUPPORTED FUNCTIONS AND USAGE	29

12.3.1	03 read from holding registers	30
12.3.2	04 read from input registers	30
12.3.3	06 write to a single holding register	31
12.3.4	16 (10 HEX) write to one or more registers	31
12.3.5	17 (11HEX) report slave id	32
12.3.6	77 (4D HEX) read measurement string	33
12.3.7	82 (52 HEX) re-read output buffer	35
12.4	ERROR RESPONSES	35
12.4.1	Exception codes	36
<hr/>		
13.	MODBUS ADDRESS MAP FOR AC MEASUREMENT TRANSDUCERS	37
14.	MODBUS ADDRESS MAP FOR DC MEASUREMENT TRANSDUCERS	43
15.	MODBUS DATA TYPES	44

BLANK PAGE

7. INTRODUCTION

iSTAT **I400** digital transducers provide local and remote indication for precision electrical measurement and control when used with instruments, recorders, data loggers and SCADA (Supervisory Control and Data Acquisition) systems.

The **I400** range contains the following type of devices:

(1) A.C. input transducers

- I4CA Mean-Sensing Current (single phase)
- I4VA Mean-Sensing Voltage (single phase)
- I4CD, I4CF RMS Current (single-, three-phase)
- I4VD, I4VF RMS Voltage (single-, three-phase)
- I4F Frequency
- I4P Phase Angle
- I4W Watts
- I4R VARs
- I4M Multi-function (**does not include i4MT, i4MC or i4MV**)
- I4E Multi-function Energy

(2) D.C. input transducers

- I4DA Tap Position Indicator (T.P.I.)
- I4DB D.C. Voltage
- I4DC D.C. Current
- I4DF Resistance
- I4DG Temperature (RTD input)

(3) Ancillary Equipment

- I4X Communications Interfaces (separate manual)

Provision of both analogue outputs, pulsed electronic switches (I4E only) and MODBUS communication allows integration within existing sites and also in new facilities, where digital communications can be used.

The software package QDSP is used to program the **I400** transducers. The ease of programmability of digital transducers is an important feature in the provision of cost effective system control. Systems can be easily changed or expanded as required. Scaling may be programmed on site, thereby avoiding costly project delays.

NOTE: When programming a transducer using the QDSP, it may additionally be necessary to physically change jumper positions within the transducer case. Refer to section 9.3 for further details.

Applications are found in electrical utilities, energy management systems, SCADA, building management and control systems, and process control environments.

8. TECHNICAL DATA

8.1 Input Ratings – A.C. transducers

8.1.1 Voltage transducers

Mean-sensing:

Nominal voltage (U_n) 57.7V, 63.5V, 69.3V, 100V, 110V, 120V, 127V, 220V, 240V, 380V, 400V, 415V, 440V

Measuring range 10 to 120% U_n

Burden 2 VA

Overload 1.2 x U_n continuously
2 x U_n for 1s

RMS:

Nominal voltage (U_n) 50 – 500 V

Measuring range 0 to 120% U_n

Burden 1mA x U_n

Overload 1.5 x U_n continuously
2 x U_n for 1s

8.1.2 Current transducers

Mean-sensing:

Nominal current (I_n) 1A, 1.2A, 5A, 6A

Measuring range 0 to 120% I_n

Burden 2 VA

Overload 2 x I_n continuously
20 x I_n for 1s

RMS:

Nominal current (I_n) 0.5A - 5A

Measuring range 0 to 120% I_n

Burden 0.5 VA

Overload 2 x I_n continuously
20 x I_n for 1s

8.1.3 Frequency transducers

Nominal frequency (f_n) 50Hz or 60Hz

Measuring range 45Hz to 65Hz

Burden (voltage circuit) 1mA x U_n

Overload (voltage circuit) 1.2 x U_n continuously
2 x U_n for 1s

8.1.4 Watts, VArS, Phase Angle

Nominal voltage (U_n)	50 – 500V
Nominal current (I_n)	0.5A - 5A
Measuring range	0 to 120% I_n , 0 to 120% U_n
Burden (voltage circuit)	1mA x U_n
Overload (voltage circuit)	1.2 x U_n continuously 2 x U_n for 1s
Burden (current circuit)	0.5 VA
Overload (current circuit)	2 x I_n continuously 20 x I_n for 1s

8.1.5 Multi-function transducers

Nominal voltage (U_n)	50 – 500V
Nominal current (I_n)	0.5A - 5A
Measuring range	0 to 120% I_n , 0 to 120% U_n
Burden (voltage circuit)	0.2mA x U_n
Overload (voltage circuit)	1.5 x U_n continuously 2 x U_n for 1s
Burden (current circuit)	$0.01\Omega \times I_n^2$
Overload (current circuit)	2 x I_n continuously 20 x I_n for 1s

8.2 Input Ratings – D.C. transducers (i4D)**8.2.1 General**

Some of the DC Transducers are defined with different measurement ranges available. It is important that the correct range is selected when ordering as the top of the required measurement range cannot be set below the bottom of the unit's range, i.e. if DC Voltage 1V to 50V unit is purchased the top of the configured range can not be set below 1V.

8.2.2 Tap Position Indicator

Nominal resistance (R_n)	100 Ω to 500k Ω
Number of steps	1 to 100
Minimum step value	30 Ω
Measuring voltage	<2.2V
Lead resistance	<50 Ω per lead
Burden	<0.5 VA

8.2.3 D.C. Voltage

Nominal voltage (U_n)	± 50 mV to ± 300 V programmable	
Measuring ranges	50mV to 1V 1V to 50 V 50V to 300V	Input impedance >2.5M Ω Input impedance 250k Ω Input impedance 2.5M Ω
Burden	<0.5 VA	
Overload	1.2 x U_n permanently 2 x U_n for 1s	

8.2.4 D.C. Current

Nominal current (I_n)	0 – ± 100 mA (programmable)	
Measuring ranges	1mA to 10mA	Input impedance 100 Ω
	10mA to 100mA	Input impedance 10 Ω
Burden	<0.5 VA	
Overload	2 x I_n continuously 20 x I_n for 1s	

8.2.5 Resistance

Nominal resistance (R_n)	10 Ω to 50k Ω (programmable) 100 Ω to 500k Ω (programmable)	
Measuring voltage	<2.2V	
Lead resistance	<10 Ω per lead	
Burden	<0.5 VA	

8.2.6 Temperature (RTD)

RTD sensor type	Pt100, Pt1000, Ni100	
Measuring method	2-wire, 3-wire or 4-wire	
Measuring ranges	-200 $^{\circ}$ C to 850 $^{\circ}$ C (Pt), -60 $^{\circ}$ C to 250 $^{\circ}$ C (Ni) (programmable)	
RTD sensor limit values	20 Ω to 10k Ω	
Measuring voltage	<2.2V	
Lead resistance	<10 Ω per lead	
Burden	<0.5 VA	

8.3 Auxiliary Supply Input

8.3.1 Universal AC/DC auxiliary supply

	Nominal voltage	Operative range
DC	24 V to 220 V	19 V to 300 V
AC	50 V to 230 V (40...70 Hz)	40 V to 276 V (40...70 Hz)
Burden	<3VA	

8.3.2 AC auxiliary supply

	Nominal voltage (Ur)	Operative range
AC	57.7 V 63.5 V 69.3 V 100 V 110 V 115 V 120 V 208 V 230 V	80...120 % Ur
Frequency	Range 45...65 Hz	
Burden	<3VA	

8.4 Analogue Output Ratings – A.C. transducers

8.4.1 Output Ranges

DC Current output

Nominal values 0..1mA, -1..0..1mA, 0..5mA, -5..0..5mA, 0..10mA, -10..0..10mA, 0..20mA, 4..20mA, -20..0..20mA

Compliance voltage 15V (10V for i4CA, i4VA)

Response time (0...99.5%) <300 ms

DC Voltage output

Nominal values 0..1V, -1..0..1V, 0..10V, -10..0..10V

Maximum current 20mA

Response time (0...99.5%) <300 ms

8.4.2 Accuracy

EN 60688 (analogue outputs) and via communications.

% of full scale unless otherwise stated.

Voltage (Mean Sensing/RMS) $\pm 0.5\%$

Voltage (Suppressed Zero RMS) $\pm 0.5\% U_n$

Phase current $\pm 0.5\%$

Neutral current $\pm 1\%$

Power $\pm 0.5\%$

Phase angle $\pm 0.2^\circ$

Demand values $\pm 1\%$

Frequency $\pm 0.1\%$ (0.01% via communications) *

THD $\pm 1\%$

* Accuracy of frequency is % of centre scale frequency

8.5 Analogue Output Ratings – D.C. transducers

8.5.1 Output Ranges

DC Current output

Nominal values 0..1mA, -1..0..1mA, 0..5mA, -5..0..5mA, 0..10mA, -10..0..10mA, 0..20mA, 4..20mA, -20..0..20mA

Compliance voltage 15V

Response time (0...99.5%) 500 ms

DC Voltage output

Nominal values 0..1V, -1..0..1V, 0..10V, -10..0..10V

Maximum current 20mA

Response time (0...99.5%) 500 ms

8.5.2 Accuracy

Analogue outputs and via communications.

% of full scale.

T.P.I. $\pm 0.5\%$

DC Voltage DC $\pm 0.5\%$

Current Resistance $\pm 0.5\%$

Temperature (RTD) $\pm 0.5\%$

$\pm 0.5\%$

8.6 Pulsed energy switches (I4E)

8.6.1 Output range

Type Pulsed electronic switch

Pulse width 2 to 510 ms

Signal level 40V ac or dc maximum, 27mA maximum resistive load

8.6.2 Accuracy

Energy Active energy Class 1, Reactive energy Class 2 (EN61036 and EN61268)

8.7 Communication ports

8.7.1 EIA232 Port

Connection type Point to point

Signal levels EIA232

Cable type Screened multi-core

Maximum cable length 15m

Connector Screw terminals

Isolation 3.7kV rms for 1 minute between all terminals and all other circuits

Transmission mode Asynchronous

Protocol MODBUS RTU

Data rate 1200 to 115200 bits/s

8.7.2 EIA485 Port

Connection type	Multi-drop (32 connections per link)
Signal levels	EIA485
Cable type	Screened twisted pair
Maximum cable length	1000m
Connector	Screw terminals
Isolation	3.7kV rms for 1 minute between all terminals and other circuits
Transmission mode	Asynchronous
Protocol	MODBUS RTU
Data rate	1200 to 115200 bits/s

8.8 Electrical EnvironmentInsulation

EN 61010-1: 1990 Insulation Class II (500V RMS)
Tested at 3.7kV peak

EMC compliance

2004/108/EC

The following generic standards were used to establish conformity.

EN 61326-1: 1997 Electrical equipment for measurement, control, and laboratory use.

EMC Requirements

Low Voltage Directive

2006/95/EC

The following generic standards were used to establish conformity.

EN 61010-1: 2002 Electrical equipment for measurement, control, and laboratory use.

8.9 Environmental Conditions**8.9.1 Atmospheric environment**Temperature and humidity

EN 60688: 1992 Class 2

JVF (DIN 40 040)

Nominal range of operation -10°C to 55°C

Storage and transit -40°C to 70°C

Temperature coefficient (A.C. transducers) 0.02% / °C

Temperature coefficient (D.C. transducers) 0.05% / °C

Annual mean relative humidity ≤ 75%

8.9.2 Construction

Material	Flammability protection	UL 94 V-0
Enclosure protection	IEC 60529: 1989	IP 50 (IP 20 for connection terminals)
Mounting	EN 50022: 1978	DIN rail 35x15 mm
Dimensions	100mm Case	100x75x104.5 mm
	45mm Case	45x75x104.5 mm
Weight	AC auxiliary supply units	<0.6kg
	Universal aux. supply units	<0.5kg

9. INSTALLATION

9.1 Dimensions

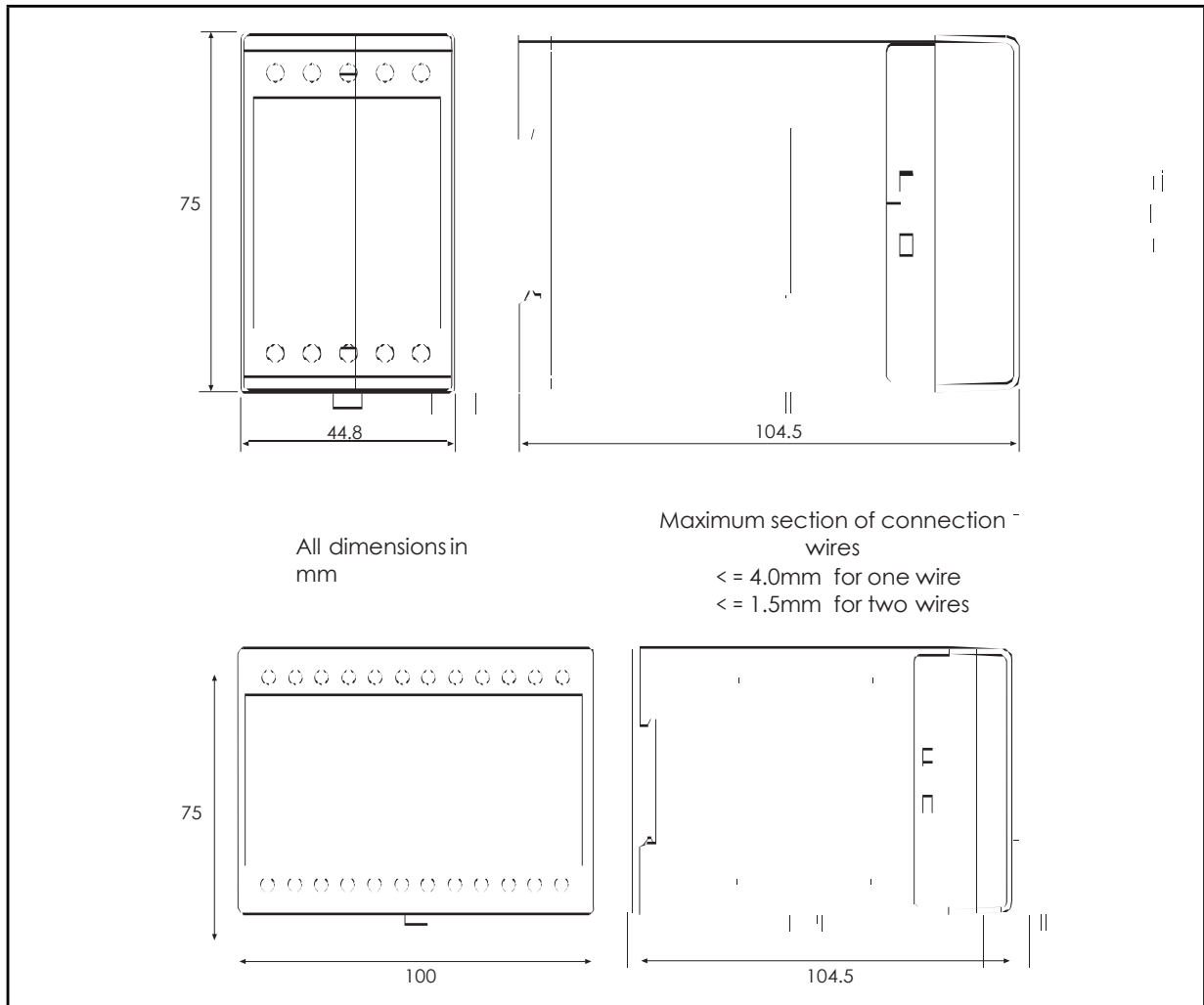

FIGURE 1 : I400 DIMENSIONS

Models with case width 44.8mm	I4CA, I4VA, I4CD, I4VD, I4F and I4D
Models with case width 100mm	I4P, I4W, I4R, I4M and I4E

9.2 Mounting

Mounting is at the rear of the unit, for 35x15 mm DIN rail according to EN 50022: 1978 .

9.3 Internal Jumpers

On programmable models of transducers, the analogue output values can be programmed using the QDSP software via the EIA232 or EIA485 communication port. However, before this is done, the hardware output range of each analogue output must be selected, on some versions (i4C, i4V, i4F, i4Dx) and on early models of other variants a physical jumper position on the output module within the transducer case needs to be changed. On later models (except i4C, i4V, i4F, i4Dx) the configuration is done completely using the configuration software and no physical changes will be required.

It is possible to choose between three hardware output ranges:

- 0...±5 mA
- 0...±20 mA
- 0...±10 V

By selecting one of these three hardware output ranges, it is possible to program any linear or multiple-slope (with maximum 5 break points) output characteristic using the QDSP setting software.

Caution: Electrical adjustments



Equipment that requires direct physical adjustments to their operating mechanism to change current or voltage settings, should have the electrical power removed before making the change, to avoid any risk of electrical shock.

Where the internal jumper needs to be set, the location of the jumpers is as shown in the diagram below. Single output transducers will have only Jumper 1 fitted.

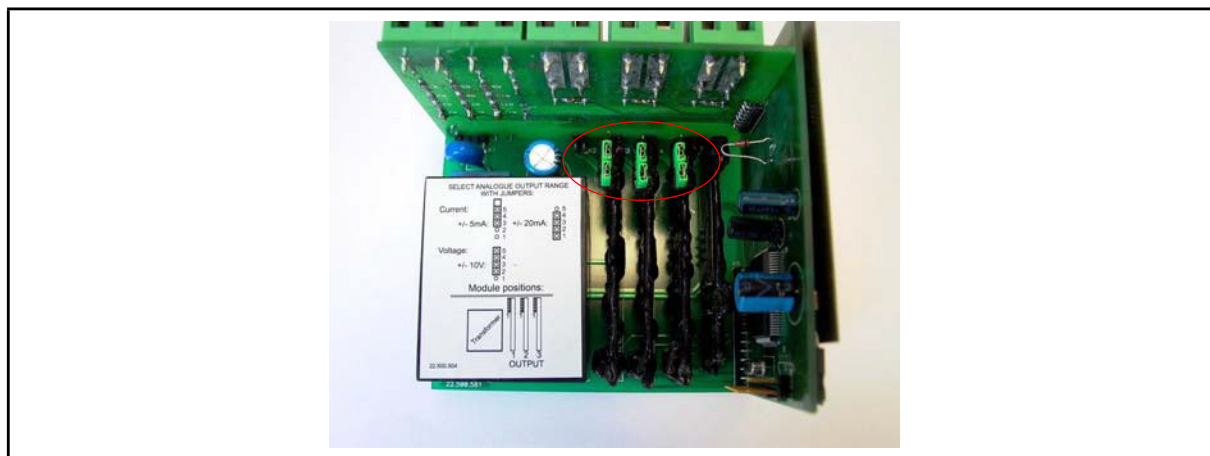

FIGURE 2 : I400 JUMPER POSITIONS

For information, the QDSP setting software displays for each analogue output, on the Output graphical display in the Device Settings window, the positions to which the jumpers must be set to match the currently-selected output type.

If it is attempted in QDSP to select an output range which is not in the currently-selected hardware range, QDSP will display an error message, to indicate that the jumper positions must be physically changed.

10. CONNECTIONS

10.1 Auxiliary Supply Connection

An auxiliary power supply is necessary for all I400 transducers, except for the self-powered mean sensing current and voltage transducers (I4CA and I4VA).

10.1.1 A.C. auxiliary supply

If the I400 transducer is fitted with an A.C. auxiliary supply, the terminal allocations are as follows:

Terminal Number	Terminal Marking	Description
13	~	Live
14	~	Neutral

10.1.2 Universal auxiliary supply

If the I400 transducer is fitted with a universal AC/DC auxiliary supply, the terminal allocations are as follows:

Terminal Number	Terminal Marking	Description
13	+/~	+ / Live
14	-/~	Common / Neutral

10.2 Communications Connections

To be able to establish communication with an I400 unit, it has to be physically connected to the serial port of the computer or Remote Terminal Unit, etc.

I400 transducer connections are identified on the transducer label beside the screw terminals. In order to communicate with the device, auxiliary power must be applied to the device, and the communications connection must be correctly wired.

10.2.1 EIA232 port

If the I400 transducer is fitted with an EIA232 communications port, the terminal allocations are as follows:

Description	I400 Terminal number	Terminal marking	RS232 9 pin connection
			PC Terminal
Receive	21 (23 I4M4 only)	Rx	3
Signal Ground	22 (24 I4M4 only)		5
Transmit	23 (25 I4M4 only)	Tx	2

The EIA232 communications port is configured as a DTE (Data Terminal Equipment) device, which means that a crossover cable will be required to connect to a standard EIA232 serial port on a PC (also a DTE). The maximum connection length is 15 metres.

10.2.2 EIA485 port

If the I400 transducer is fitted with an EIA485 communications port, the terminal allocations are as follows:

Terminal Number	Terminal Marking	Description
21 (23 I4M4 only)	A	TxRxA (DATA+)
22 (24 I4M4 only)	C	No connection
23 (25 I4M4 only)	B	TxRxB (DATA-)

Two-wire EIA485 only is used. An EIA485 port will be required on the Master system and on any PC being used with QDSP an external EIA485 (2-wire) interface is required connected to the PC's USB (or EIA232) port. The maximum connection length is 1000 metres. Conductors A and B should be terminated with a 120Ω terminating resistor.

10.3 Input Connections

10.3.1 A.C. input transducers

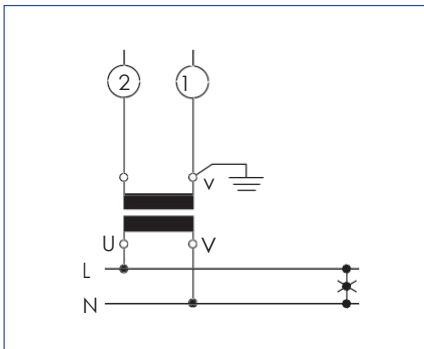

Volts, frequency

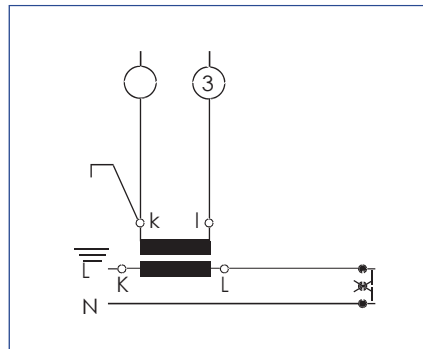

Current

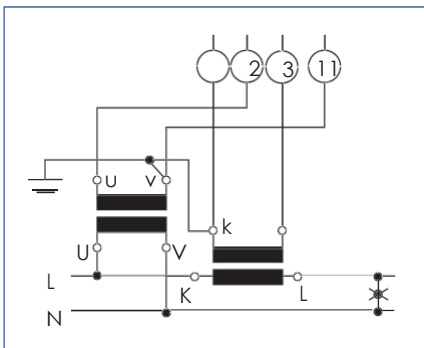

Power - single phase

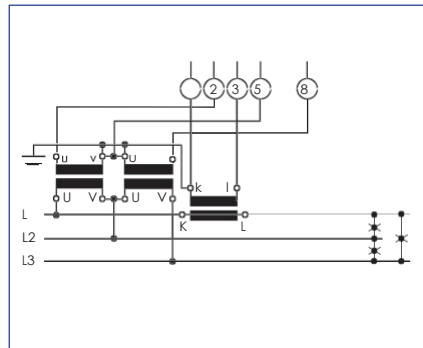

Power - 3 wire balanced

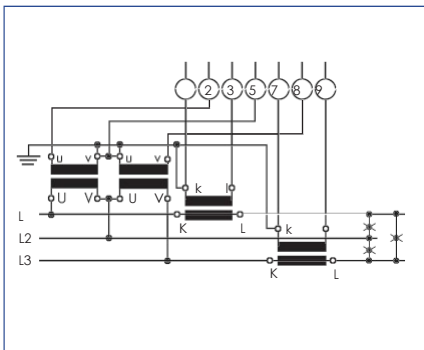

Power - 3 wire unbalanced

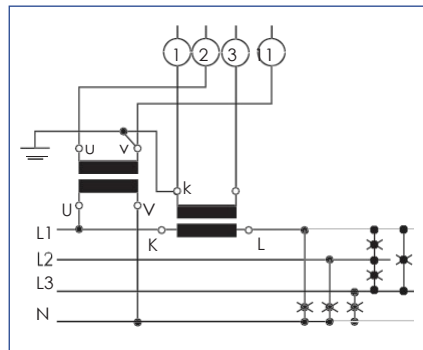

Power - 4 wire balanced

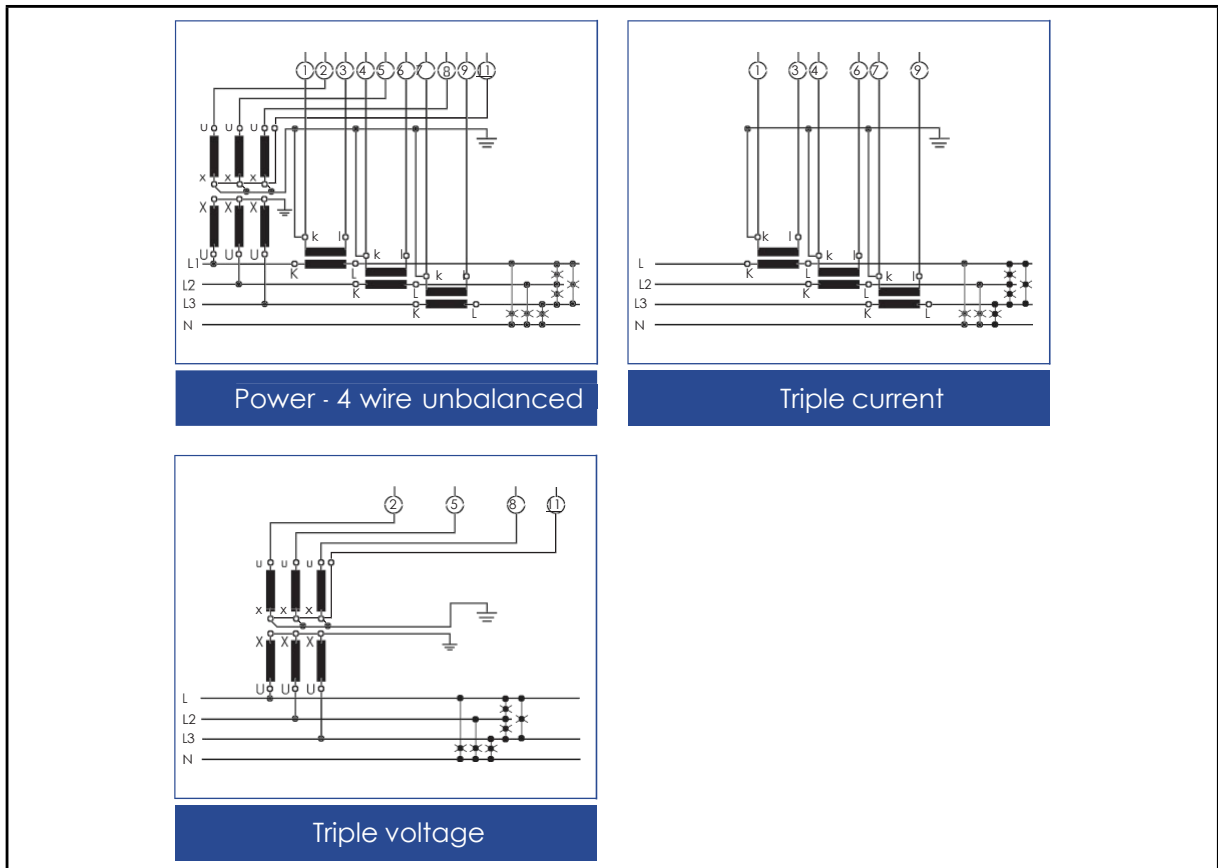

NOTE: The diagrams referred to as 'Power' are applicable to Watt, VAR, Phase Angle and Multifunction transducers.

10.3.2 D.C. input transducers

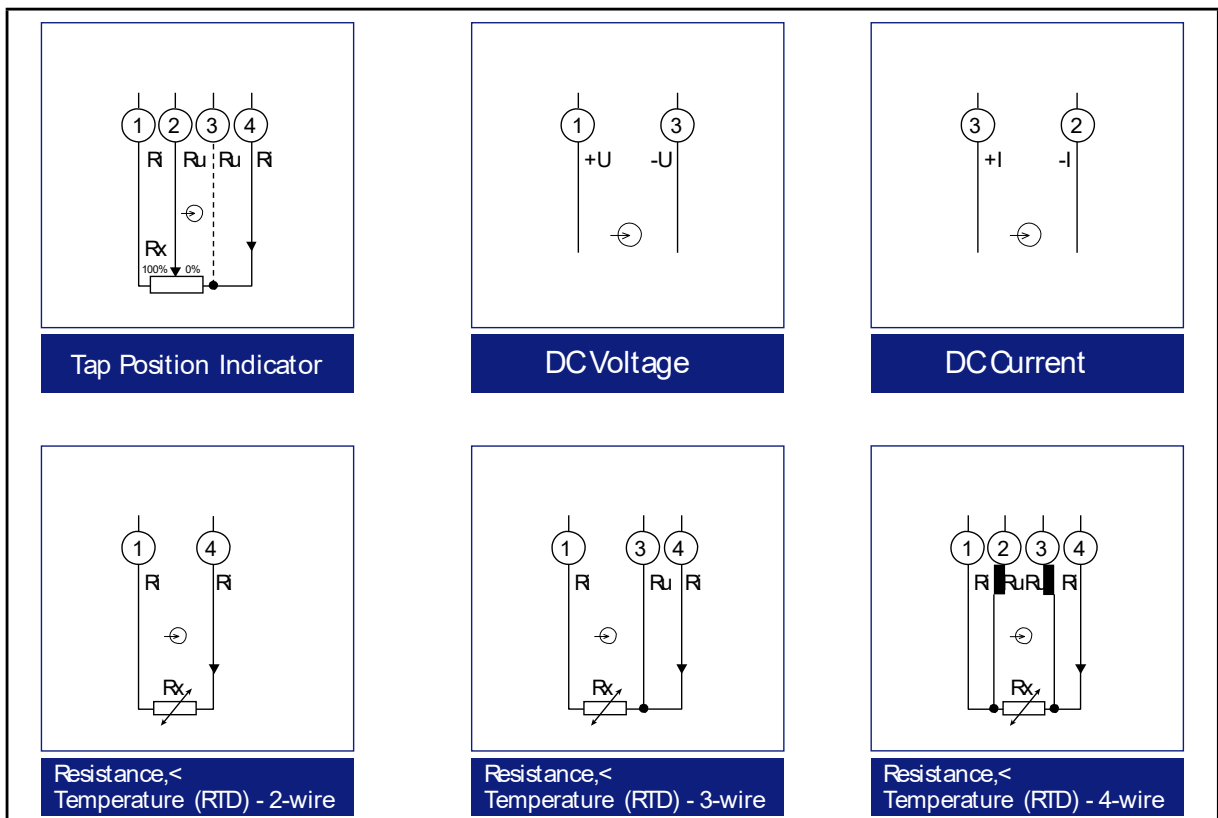

10.4 Output Connections

The I400 transducer output terminal allocations are as follows, where fitted:

Terminal Number	Terminal Marking	Description
15	+	Output 1 +
16	–	Output 1 –
17	+	Output 2 +
18	–	Output 2 –
19	+	Output 3 +
20	–	Output 3 –
21 (I4M4 only)	–	Output: 4+
22 (I4M4 only)	–	Output: 4 –

By default single output transducers always use Output 1 terminals (15 and 16).

I4M Multifunction transducers may be fitted with none, one, two, three or four outputs depending on order option.

I4E Multifunction energy transducers are always fitted with a pulse electronic switch on Output 1 terminals (15 and 16). If fitted, the other two outputs can be ordered as either additional electronic switches or analogue outputs.

All D.C. input transducers are single output transducers.

11. RELATED DOCUMENTS

Ref	Title
1	QDSP Technical Manual
2	Application Guide for Electrical Measuring Transducers

12. MODBUS IMPLEMENTATION

12.1 TRANSACTIONS

Communication operates on a master-slave basis where only one device (the master) can initiate transactions called 'Requests'. The other devices (slaves) respond by supplying the requested data to the master. This is called the 'Request - Response Cycle'.

Master to slave request:

Device address	Function Code	nx8 bit data bytes	Error check
----------------	---------------	--------------------	-------------

Slave to master response:

Device address	Function Code	nx8 bit data bytes	Error check
----------------	---------------	--------------------	-------------

12.1.1 Request

This Master to Slave transaction takes the form:

Device address:

Master addressing a slave (Address 0 is used for the broadcast address, which all slave devices recognise.)

Function code:

E.g. 03 asks the slave to read its Holding registers and respond with their contents.

Data bytes:

Tells the slave which register to start at and how many registers to read.

12.1.2 Response

This Slave to Master transaction takes the form:

Device address:

To let the master know which slave is responding.

Function code:

This is an echo of the request function code.

Data bytes:

Contains the data collected from the slave.

12.1.3 Example of Request - Response cycle

Input to I400 transducer: Van = 57.4 V 50Hz

Data held in Input Registers: 30057₍₁₀₎ & 30058₍₁₀₎
 Starting register 30057₍₁₀₎ - 30000₍₁₀₎ offset = 57₍₁₀₎ = 00 39₍₁₆₎

12.1.3.1 Request Frame

		Starting Register	Register Count	CRC
Slave Address	Function code	HI LO	HI LO	LO HI
21	04	00 39	00 02	

12.1.3.2 Response Frame

			Register Data	CRC
Slave Address	Function code	Byte count	HI LO HI LO	LO HI
21	04	04	FD 00 E0 1F	

Response register data, FD 00 E0 1F, is decoded as:

Exponent (8 m.s.b., signed) = $FD_{(16)} = -3_{(10)}$

Value (24 l.s.b., unsigned) = $00 E0 1F_{(16)} = 57375_{(10)}$

Complete number (decimal) = $57375 \times 10^{-3} = 57.375 \text{ V}$

12.2 FRAMING

There are two types of message framing for Modbus serial communications, ASCII or RTU. The I400 family of transducers supports RTU framing only.

12.2.1 RTU framing

In RTU mode, messages start and end with a silent interval of at least 3.5 character times (t1-t2-t3-t4 as shown below).

The advantage of this mode of framing is that it enables a greater character density and a better data throughput. However, each message must be transmitted in a continuous stream. If a silent interval of more than 1.5 character times occurs before completion of the frame, the device flushes the incomplete message and assumes that the next byte will be the address field of a new message.

Start	Address	Function	Data	CRC Check	End
t1-t2-t3-t4	8 bits	8 bits	n x 8 bits	16 bits	t1-t2-t3-t4

The Cyclic Redundancy Check (CRC) field is two bytes, containing a 16 bit binary value. The CRC value is calculated by the transmitting device, which appends the CRC to the message. The receiving device recalculates a CRC during receipt of the message, and compares the calculated value to the actual value it received in the CRC field. If the two values are not equal an error results. The CRC-16 calculation is an industry standard method used for error detection.

One frame is transmitted as 1 start bit, 8 data bits and 2 stop bit. If parity is selected then the frame is transmitted as 1 start bit, 8 data bits, and 1 stop bit.

Where $n > 1$ data is transmitted most significant byte first.

The CRC check is transmitted least significant byte first.

12.3 SUPPORTED FUNCTIONS AND USAGE

Code	Code	Function	References
DEC	HEX		
3	03	to read from holding registers	(4XXXX memory references)
4	04	to read from input registers	(3XXXX memory references)
6	06	to write to a single holding register	(4XXXX memory references)
16	10	to write to one or more holding registers	(4XXXX memory references)
17	11	report slave ID	6 characters
77	4D	read measurement string	1 byte value code (request)
82	52	re-read output buffer	Use after broadcast request

12.3.1 03 read from holding registers

Reads the content of Holding Registers (4XXXX references) in the slave. Broadcast is also supported.

12.3.1.1 Request Frame

The query message specifies the starting register and quantity of registers (1 to 28) to be read. Registers are addressed starting at zero.

Here is an example of a request to read register 40043 "Connection Mode" from slave device 33 (=21₍₁₆₎)

		Starting Register	Register Count	CRC
Slave Address	Function Code	HI LO	HI LO	LO HI
21	03	00 2B	00 01	

12.3.1.2 Response Frame

The register data in the response message is packed as two bytes per register, with the binary contents right justified within each byte. For each register, the first byte contains the high order bits and the second contains the low order bits.

Data is scanned in the slave at the rate of 28 registers maximum per scan. The response is returned when the data is completely assembled.

Here is an example of a response to the query:

			Register Data	CRC
Slave Address	Function Code	Byte Count	HI LO	LO HI
21	03	02	00 05	

The contents of register 40043 is 00 05 (= '4u – 3 phase 4 wire unbalanced').

12.3.2 04 read from input registers

Reads the content of Input Registers (3XXXX references) in the slave. Broadcast is also supported

12.3.2.1 Request Frame

The query message specifies the starting register and quantity (1 to 28) of registers to be read. Registers are addressed starting at zero.

Here is an example of a request to read registers 30057 ... 30058 "U1" (=Van) from slave device 33:

		Starting Register	Register Count	CRC
Slave Address	Function Code	HI LO	HI LO	LO HI
21	04	00 39	00 02	

12.3.2.2 Response Frame

The register data in the response message is packed as two bytes per register, with the binary contents right justified within each byte. For each register, the first byte contains the high order bits and the second contains the low order bits.

Data is scanned in the slave at the rate of 28 registers maximum per scan. The response is returned when the data is completely assembled.

Here is an example of a response to the query:

			Register Data	Register Data	CRC
Slave Address	Function Code	Byte Count	HI LO	HI LO	LO HI
21	04	04	FD 00	E0 1F	

The contents of registers 30036 ... 30037 are FD 00 and E0 1F hex.

12.3.3 06 write to a single holding register

Pre-sets a value into a single holding register (4XXXXX reference). When broadcast, the function pre-sets the same register reference in all attached slaves.

12.3.3.1 Request Frame

The query message specifies the register reference to be pre-set. Registers are addressed starting at zero; register 1 is addressed as 0.

Here is an example of a request to pre-set register 40010 "Active Access Level" to 00 02 hex (Level 2 access) in slave device 33:

		Register Address	Register Data	CRC
Slave Address	Function Code	HI LO	HI LO	LO HI
21	06	00 0A	00 02	

12.3.3.2 Response Frame

The normal response is an echo of the query, returned after the register contents have been pre-set. Here is an example of a response to the query:

		Register Address	Register Data	CRC
Slave Address	Function Code	HI LO	HI LO	LO HI
21	06	00 0A	00 02	

12.3.4 16 (10 HEX) write to one or more registers

Pre-sets values into a sequence of holding registers (4XXXXX references). When broadcast, the function pre-sets the same register references in all attached slaves.

12.3.4.1 Request Frame

The query message specifies the register references to be pre-set. Registers are addressed starting at zero; register 1 is addressed as 0. Here is an example of a request to pre-set two registers starting at 40008 to 41 41 and 41 41 hex (Enter Level 2 Password AAAA), in slave device 33:

Slave Address	Function Code	Starting Address		Register Count		Register Data				CRC	
		HI	LO	HI	LO	HI	LO	HI	LO	LO	HI
21	10	00	08	00	02	41	41	41	41		

12.3.4.2 Response Frame

The normal response returns the slave address, function code, starting address, and quantity of registers pre-set. Here is an example of a response to the query shown above.

Slave Address	Function Code	Starting Address		Register Count		CRC	
		HI	LO	HI	LO	LO	HI
21	10	00	08	00	02		

12.3.5 17 (11HEX) report slave id

Returns a description of the type of controller present at the slave address.

12.3.5.1 Request Frame

Here is an example of a request to report the ID of slave device 33:

Slave Address	Function Code	CRC	
		LO	HI
21	11		

12.3.5.2 Response Frame

The format of a normal response is shown below:

Slave Address	Function Code	Byte Count	Register Data								CRC									
			HI	LO	HI	LO	LO	HI	LO	HI									
21	11	10	49	34	4D	20	20	20	54	72	61	6E	73	64	75	63	65	72		

The string in the response is "I4M Transducer" (16 characters).

12.3.6 77 (4D HEX) read measurement string

Reads the measurement value as an ASCII string. Broadcast is also supported.

The value codes are listed in the following table:

Value Code DEC	Value Code HEX	Measurement Value	Byte Count	Example String Data
1	01	Frequency	7	"50.004 "
2	02	Frequency 1	7	"50.004 "
3	03	Frequency 2	7	"50.004 "
4	04	Frequency 3	7	"50.004 "
5	05	U1	7	"48.043k"
6	06	U2	7	"48.115k"
7	07	U3	7	"48.183k"
8	08	Uavg (phase to neutral)	7	"48.113k"
9	09	j12 (angle between U1 and U2)	7	"+000.00"
10	0A	j23 (angle between U2 and U3)	7	"+000.02"
11	0B	j31 (angle between U3 and U1)	7	"-000.02"
12	0C	U12	6	"00.07k"
13	0D	U23	6	"00.07k"
14	0E	U31	6	"00.14k"
15	0F	Uavg (phase to phase)	6	"00.09k"
16	10	I1	7	"079.94 "
17	11	I2	7	"080.58 "
18	12	I3	7	"080.40 "
19	13	IN	6	"240.9 "
21	15	Iavg	7	"080.31 "
22	16	Total I	7	"240.91 "
23	17	Active Power Total (Pt)	8	"+8147.3k"
24	18	Active Power Phase L1 (P1)	8	"+2697.6k"
25	19	Active Power Phase L2 (P2)	8	"+2724.2k"
26	1A	Active Power Phase L3 (P3)	8	"+2725.1k"
27	1B	Reactive Power Total (Qt)	12	"8225.8kvar L"
28	1C	Reactive Power Phase L1 (Q1)	12	"2727.3kvar L"
29	1D	Reactive Power Phase L2 (Q2)	12	"2750.8kvar L"
30	1E	Reactive Power Phase L3 (Q3)	12	"2747.3kvar L"
31	1F	Apparent Power Total (St)	7	"11.578M"
32	20	Apparent Power Phase L1 (S1)	7	"3836.0k"
33	21	Apparent Power Phase L2 (S2)	7	"3871.4k"
34	22	Apparent Power Phase L3 (S3)	7	"3869.6k"
35	23	Power Factor Total (PFt)	8	"+0.704 L"
36	24	Power Factor Phase 1 (PF1)	8	"+0.703 L"
37	25	Power Factor Phase 2 (PF2)	8	"+0.704 L"
38	26	Power Factor Phase 3 (PF3)	8	"+0.704 L"

Value Code DEC	Value Code HEX	Measurement Value	Byte Count	Example String Data
39	27	Power Angle Total (atan2(Pt,Qt))	7	"+045.27"
40	28	< 1 (angle between U1 and I1)	7	"+041.46"
41	29	< 2 (angle between U2 and I2)	7	"+041.05"
42	2A	< 3 (angle between U3 and I3)	7	"+041.24"
43	2B	Internal Temperature	7	"+036.84"
44	2C	U1 THD%	6	"002.81"
45	2D	U2 THD%	6	"002.70"
46	2E	U3 THD%	6	"002.70"
47	2F	U12 THD%	6	"000.55"
48	30	U23 THD%	6	"000.55"
49	31	U31 THD%	6	"000.55"
50	32	I1 THD%	6	"034.91"
51	33	I2 THD%	6	"036.34"
52	34	I3 THD%	6	"035.65"
		DYNAMIC DEMAND VALUES		
53	35	I1	10	"I1=79.70 A"
54	36	I2	10	"I2=80.07 A"
55	37	I3	10	"I3=79.91 A"
56	38	Apparent Power Total (St)	11	"St=11.53MVA"
57	39	Active Power Total (Pt) - (positive)	11	"Pt=+8.051MW"
58	3A	Active Power Total (Pt) - (negative)	11	"Pt=-0.000MW"
59	3B	Reactive Power Total (Qt) - L	14	"Qt=8.253Mvar L"
60	3C	Reactive Power Total (Qt) - C	14	"Qt=0.000Mvar C"
		MAX DEMAND SINCE LAST RESET		
61	3D	I1	10	"I1=082.6 A"
62	3E	I2	10	"I2=082.6 A"
63	3F	I3	10	"I3=082.3 A"
64	40	Apparent Power Total (St)	11	"St=12.02MVA"
65	41	Active Power Total (Pt) - (positive)	11	"Pt=+08.29MW"
66	42	Active Power Total (Pt) - (negative)	11	"Pt=-00.00MW"
67	43	Reactive Power Total (Qt) - L	14	"Qt=08.71Mvar L"
68	44	Reactive Power Total (Qt) - C	14	"Qt=00.00Mvar C"

12.3.6.1 Request Frame

The query message specifies the value code of the measurement to be read.

Here is an example of the query to read U1 (Van), value code 05, from slave device 33:

Slave Address	Function Code	Value Code	CRC	
			LO	HI
21	4D	05		

12.3.6.2 Response Frame

The ASCII string in the response message is packed as data bytes. The quantity of data bytes depends on the value code.

Here is an example of a response to the query:

Slave Address	Function Code	Byte Count	String Data							CRC	
			1.	2.	3.	4.	5.	6.	7.	LO	HI
21	4D	07	34	38	2E	30	34	33	6B		

This reply is the ASCII string "48.043k".

12.3.7 82 (52 HEX) re-read output buffer

This function should be used after the broadcast request. The addressed slave transmits the response frame of the previous request.

12.3.7.1 Request Frame

Here is an example of a request to re-read the output buffer of slave device 33:

Slave Address	Function Code	CRC	
		LO	HI
21	52		

12.3.7.2 Response Frame

The response to the query depends on the previous function code.

12.4 ERROR RESPONSES

When a slave detects an error other than a CRC error, a response will be sent to the master. The most significant bit of the function code byte will be set to 1 (i.e. the function code sent from the slave will be equal to the function code sent from the master plus 128). The following byte will be an exception code indicating the type of error that occurred.

The slave will ignore transmissions received from the master with CRC errors.

An example of an illegal request and the corresponding exception response is shown below. The request in this example is to read registers 0201H to 0209H. If these addresses are not supported in the slave then the following occurs:

Request Message				
Address	Function Code	Starting Register HI LO	Register Count HI LO	CRC
01	01	02 01	00 08	6D B4

Exception Response Message

Address	Function Code	Exception Code	CRC
01	81	02	C1 91

12.4.1 Exception codes

Code	Name	Meaning
01	ILLEGAL FUNCTION	The function code transmitted is not one of the functions supported by the slave.
02	ILLEGAL DATA ADDRESSES	The data address received in the request is not an allowable value for the slave. Write to password protected registers.
03	ILLEGAL DATA VALUE	The value referenced in the data field transmitted by the master is not within range for the selected data address. The register count is greater than 28 (functions 03 and 04).
06	SLAVE DEVICE BUSY	The slave is engaged in processing a long duration program command. The master should re-transmit the message later when the slave is free.

13. MODBUS ADDRESS MAP FOR AC MEASUREMENT TRANSDUCERS

Code	Address	Contents	Data	Ind	Values/Dependencies	Type	Min	Max	Step
	30000	memory reference							
		SYSTEM DATA							
04	30001	30008	Model Number	T_Str16	Example: I4M3	Data			
04	30009	30012	Serial Number	T_Str8		Data			
04	30013		Software Reference	T1		Data	105		
04	30014		Modbus Max. Register Read at Once	T1	Use 28 if (reg.30013) > 103	Data			
04	30015	30018	Configuration Time Stamp	T_Time		Data			
04	30019	30022	Calibration Time Stamp	T_Time		Data			
04	30023	30024	Reserved Locations						
04	30025		Hardware – I/O 4	T1	3	Jumperless Analogue Output			
04	30026		Hardware - I/O 1	T1	0	No I/O	Data		
					1	Unipolar Analogue Output			
					2	Bipolar Analogue Output			
					3	Jumperless Analogue Output			
					4	Pulse Output			
					5	Tariff Input			
04	30027		Hardware - I/O 2	T1		see Hardware - I/O 1	Data		
04	30028		Hardware - I/O 3	T1		see Hardware - I/O 1	Data		
04	30029		Hardware - Communication Type	T1	0	No Communication	Data		
					1	RS 232			
					2	RS 485			
04	30030		Hardware Configuration	T1	Bit-0	External Auxiliary Supply	Data		
					Bit-1	N - Neutral			
					Bit-2	Phase Voltage L1			
					Bit-3	Phase Voltage L2			
					Bit-4	Phase Voltage L3			
					Bit-5	Phase Current L1			
					Bit-6	Phase Current L2			
					Bit-7	Phase Current L3			
04	30037		Energy Counter 1 Exponent	T2			Data		
04	30038		Energy Counter 2 Exponent	T2			Data		

Code	Address	Contents	Data	Ind	Values/Dependencies	Type	Min	Max	Step
04	30039	Energy Counter 3 Exponent	T2			Data			
04	30040	Energy Counter 4 Exponent	T2			Data			
		AVAILABLE MEASUREMENTS							
04	30041	Measurements Parameter 1				Data			
				Bit-0	Frequency				
				Bit-4	U1				
				Bit-5	U2				
				Bit-6	U3				
				Bit-7	Uavg (phase to neutral)				
				Bit-8	ϕ_{12} (angle between U1 and U2)				
				Bit-9	ϕ_{23} (angle between U2 and U3)				
				Bit-10	ϕ_{31} (angle between U3 and U1)				
				Bit-11	U12				
				Bit-12	U23				
				Bit-13	U31				
				Bit-14	Uavg (phase to phase)				
				Bit-15	I1				
04	30042	Measurements Parameter 2				Data			
				Bit-0	I2				
				Bit-1	I3				
				Bit-2	IN				
				Bit-4	Iavg				
				Bit-5	<1				
				Bit-6	Active Power Total (Pt)				
				Bit-7	Active Power Phase L1 (P1)				
				Bit-8	Active Power Phase L2 (P2)				
				Bit-9	Active Power Phase L3 (P3)				
				Bit-10	Reactive Power Total (Qt)				
				Bit-11	Reactive Power Phase L1 (Q1)				
				Bit-12	Reactive Power Phase L2 (Q2)				
				Bit-13	Reactive Power Phase L3 (Q3)				
				Bit-14	Apparent Power Total (St)				
				Bit-15	Apparent Power Phase L1 (S1)				

Code	Address	Contents	Data	Ind	Values/Dependencies	Type	Min	Max	Step
04	30043	Measurements Parameter 3				Data			
				Bit-0	Apparent Power Phase L2 (S2)				
				Bit-1	Apparent Power Phase L3 (S3)				
				Bit-2	Power Factor Total (PFt)				
				Bit-3	Power Factor Phase 1 (PF1)				
				Bit-4	Power Factor Phase 2 (PF2)				
				Bit-5	Power Factor Phase 3 (PF3)				
				Bit-6	Power Angle Total (atan2(Pt,Qt))				
				Bit-7	ϕ_1 (angle between U1 and I1)				
				Bit-8	ϕ_2 (angle between U2 and I2)				
				Bit-9	ϕ_3 (angle between U3 and I3)				
				Bit-10	Internal Temperature				
				Bit-11	U1 THD%				
				Bit-12	U2 THD%				
				Bit-13	U3 THD%				
				Bit-14	U12 THD%				
				Bit-15	U23 THD%				
04	30044	Measurements Parameter 4				Data			
				Bit-0	U31 THD%				
				Bit-1	I1 THD%				
				Bit-2	I2 THD%				
				Bit-3	I3 THD%				
				Bit-8	Energy Counter 1				
				Bit-9	Energy Counter 2				
				Bit-10	Energy Counter 3				
				Bit-11	Energy Counter 4				
04	30045	Measurements Parameter 5				Data			
				Bit-0	MD I1				
				Bit-1	MD I2				
				Bit-2	MD I3				
				Bit-3	MD St				
				Bit-4	MD Pt1				
				Bit-5	MD Pt2				
				Bit-6	MD Qt1				
				Bit-7	MD Qt2				

Code	Address		Contents	Data	Ind	Values/Dependencies	Type	Min	Max	Step
04	30108	30109	Apparent Power Phase L1 (S1)	T5		VA	Data			
04	30110	30111	Apparent Power Phase L2 (S2)	T5		VA	Data			
04	30112	30113	Apparent Power Phase L3 (S3)	T5		VA	Data			
04	30114	30115	Power Factor Total (PFt)	T7			Data			
04	30116	30117	Power Factor Phase 1 (PF1)	T7			Data			
04	30118	30119	Power Factor Phase 2 (PF2)	T7			Data			
04	30120	30121	Power Factor Phase 3 (PF3)	T7			Data			
04	30122		Power Angle Total (atan2(Pt,Qt))	T17		deg	Data	-180.00	179.99	0.01
04	30123		$\phi 1$ (angle between U1 and I1)	T17		deg	Data	-180.00	179.99	0.01
04	30124		$\phi 2$ (angle between U2 and I2)	T17		deg	Data	-180.00	179.99	0.01
04	30125		$\phi 3$ (angle between U3 and I3)	T17		deg	Data	-180.00	179.99	0.01
04	30126		Internal Temperature	T17		deg C	Data			
			ENERGY							
04	30134	30135	Energy Counter 1	T3			Data	-99999999	89999999	1
04	30136	30137	Energy Counter 2	T3			Data	-99999999	89999999	1
04	30138	30139	Energy Counter 3	T3			Data	-99999999	89999999	1
04	30140	30141	Energy Counter 4	T3			Data	-99999999	89999999	1
			DEMAND VALUES							
			DYNAMIC DEMAND VALUES							
04	30175	30176	I1	T5			Data			
04	30177	30178	I2	T5			Data			
04	30179	30180	I3	T5			Data			
04	30181	30182	Apparent Power Total (St)	T5			Data			
04	30183	30184	Active Power Total (Pt) - (positive)	T6			Data			
04	30185	30186	Active Power Total (Pt) - (negative)	T6			Data			

Code	Address		Contents	Data	Ind	Values/Dependencies	Type	Min	Max	Step
04	30187	30188	Reactive Power Total (Qt) - L	T6			Data			
04	30189	30190	Reactive Power Total (Qt) - C	T6			Data			
			MAX DEMAND SINCE LAST RESET							
04	30207	30208	I1	T5			Data			
04	30213	30214	I2	T5			Data			
04	30219	30220	I3	T5			Data			
04	30225	30226	Apparent Power Total (St)	T5			Data			
04	30231	30232	Active Power Total (Pt) - (positive)	T6			Data			
04	30237	30238	Active Power Total (Pt) - (negative)	T6			Data			
04	30243	30244	Reactive Power Total (Qt) - L	T6			Data			
04	30249	30250	Reactive Power Total (Qt) - C	T6			Data			
			THD HARMONIC DATA							
04	30639		U1 THD%	T16			Data			
04	30640		U2 THD%	T16			Data			
04	30641		U3 THD%	T16			Data			
04	30642		U12 THD%	T16			Data			
04	30643		U23 THD%	T16			Data			
04	30644		U31 THD%	T16			Data			
04	30645		I1 THD%	T16			Data			
04	30646		I2 THD%	T16			Data			
04	30647		I3 THD%	T16			Data			

15. MODBUS DATA TYPES

Type	Value / Bit Mask	Description
T1		Unsigned Value (16 bit) Example: 12345 stored as 12345 = 3039 ₍₁₆₎
T2		Signed Value (16 bit) Example: -12345 stored as -12345 = CFC7 ₍₁₆₎
T3		Signed Long Value (32 bit) Example: 123456789 stored as 123456789 = 075B CD 15 ₍₁₆₎
T4	bits # 15..14 bits # 13..00	Short Unsigned float (16 bit) Decade Exponent(Unsigned 2 bit) Binary Unsigned Value (14 bit) Example: 10000*10 ² stored as A710 ₍₁₆₎
T5	bits # 31..24 bits # 23..00	Unsigned Measurement (32 bit) Decade Exponent(Signed 8 bit) Binary Unsigned Value (24 bit) Example: 123456*10 ⁻³ stored as FD01 E240 ₍₁₆₎
T6	bits # 31..24 bits # 23..00	Signed Measurement (32 bit) Decade Exponent (Signed 8 bit) Binary Signed value (24 bit) Example: - 123456*10 ⁻³ stored as FDFE 1DC0 ₍₁₆₎
T7	bits # 31..24 bits # 23..16 bits # 15..00	Power Factor (32 bit) Sign: Import/Export (00/FF) Sign: Inductive/Capacitive (00/FF) Unsigned Value (16 bit), 4 decimal places Example: 0.9876 CAP stored as 00FF 2694 ₍₁₆₎
T8	bits # 31..24 bits # 23..16 bits # 15..08 bits # 07..00	Time stamp (32 bit) Minutes 00 - 59 (BCD) Hours 00 - 23 (BCD) Day of month 01 - 31 (BCD) Month of year 01 - 12 (BCD) Example: 15:42, 1. SEP stored as 4215 0109 ₍₁₆₎
T9	bits # 31..24 bits # 23..16 bits # 15..08 bits # 07..00	Time (32 bit) 1/100s 00 - 99 (BCD) Seconds 00 - 59 (BCD) Minutes 00 - 59 (BCD) Hours 00 - 24 (BCD) Example: 15:42:03.75 stored as 7503 4215 ₍₁₆₎

Type	Value / Bit Mask	Description
T10	bits # 31..24 bits # 23..16 bits # 15..00	Date (32 bit) Day of month 01 - 31 (BCD) Month of year 01 - 12 (BCD) Year (unsigned integer) 1998..4095 Example: 10, SEP 2000 stored as 1009 07D0 ₍₁₆₎
T_Str4 (T11)		Text String 4 characters Two characters per 16 bit register
T_Str6 (T12)		Text String 6 characters Two characters per 16 bit register
T_Str8		Text String 8 characters Two characters per 16 bit register.
T_Str16		Text String 16 characters Two characters per 16 bit register.
T_Str20		Text String 20 characters Two characters per 16 bit register.
T16		Unsigned Value (16 bit), 2 decimal places Example: 123.45 stored as 123.45 = 3039 ₍₁₆₎
T17		Signed Value (16 bit), 2 decimal places Example: -123.45 stored as -123.45 = CFC7 ₍₁₆₎
T18		Unsigned Value (16 bit), 1 decimal palce Example: 1234.5 stored as 1234.5 = 3039 ₍₁₆₎
T19		Signed Value (16 bit), 1 decimal palce Example: -1234.5 stored as -1234.5 = CFC7 ₍₁₆₎
T_Time	bits # 63..56 bits # 55..48 bits # 47..40 bits # 39..32 bits # 31..24 bits # 23..16 bits # 15..00	Time and Date (64 bit) 1/100s 00 - 99 (BCD) Seconds 00 - 59 (BCD) Minutes 00 - 59 (BCD) Hours 00 - 24 (BCD) Day of month 01 - 31 (BCD) Month of year 01 - 12 (BCD) Year (unsigned integer) 1998..4095 Example: 15:42:03.75, 10. SEP 2000 stored as 7503 4215 1009 07D0 ₍₁₆₎

Type	Value / Bit Mask	Description
T_TimeIEC	bits # 63..55 bits # 54..48 bits # 47..44 bits # 43..40 bits # 39..37 bits # 36..32 bit # 31 bits # 30..29 bits # 28..24 bit # 23 bit # 22 bits # 21..16 bits # 15..00	Time and Date (64 bit) = IEC870-5-4 "Binary Time 2a" Reserved Years (0 .. 99) Reserved Months (1 .. 12) Day of Week (1 .. 7) Day of Month (1 .. 31) Summer Time (0 .. 1): Summer time (1), Standard time (0) Reserved Hours (0 .. 23) Invalid (0 .. 1): Invalid (1), Valid (0) Reserved Minutes (0 .. 59) Milliseconds (0 .. 59999) Example: 15:42, 1. SEP stored as 4215 0109 ₍₁₆₎
T_Data		Record Data Size and Subtypes depends on the Actual Memory Part
T4c	bits # 15..14 bits # 13..00	Short Unsigned float (16 bit), 3 decimal places Decade Exponent (Unsigned 2 bit) Binary Unsigned Value (14 bit) Example: $10.000 \cdot 10^2$ stored as A710 ₍₁₆₎



GE VERNOVA

GE Vernova
St Leonards Building
Redhill Business Park
Stafford, ST16 1WT, UK
+44 (0) 1785 250 070
www.governova.com/grid-solutions/contact.htm

© 2025 GE Vernova. All rights reserved. Information contained in this document is indicative only.
No representation or warranty is given or should be relied on that it is complete or correct or will apply to any particular project.
This will depend on the technical and commercial circumstances. It is provided without liability and is subject to change without notice.
Reproduction, use or disclosure to third parties, without express written authority, is strictly prohibited.

I400/EN/M/Fx