

iSTAT i4MT

3-Phase Multifunction Transducer

Manual

Publication reference: i4MT/EN/M/C



GE VERNOVA

1. SAFETY SECTION





This Safety Section should be read before commencing any work on the equipment.

1.1 Health and Safety

The information in the Safety Section of the product documentation is intended to ensure that products are properly installed and handled in order to maintain them in a safe condition. It is assumed that everyone who will be associated with the equipment will be familiar with the contents of the Safety Section.

1.2 Explanation of symbols and labels

The meaning of symbols and labels may be used on the equipment or in the product documentation, is given below.

	
Caution: refer to product documentation	Caution: risk of electric shock
	
Protective/safety *earth terminal	Functional *earth terminal Note: This symbol may also be used for a protective/safety earth terminal if that terminal is part of a terminal block or sub-assembly e.g. power supply.

*NOTE: The term earth used throughout the product documentation is the direct equivalent of the North American term ground.

2. INSTALLING, COMMISSIONING AND SERVICING



Equipment connections

Personnel undertaking installation, commissioning or servicing work on this equipment should be aware of the correct working procedures to ensure safety. The product documentation should be consulted before installing, commissioning or servicing the equipment.

Terminals exposed during installation, commissioning and maintenance may present a hazardous voltage unless the equipment is electrically isolated.

If there is unlocked access to the rear of the equipment, care should be taken by all personnel to avoid electrical shock or energy hazards.

Voltage and current connections should be made using insulated crimp terminations to ensure that terminal block insulation requirements are maintained for safety. To ensure that wires are correctly terminated the correct crimp terminal and tool for the wire size should be used.

Before energising the equipment it must be earthed using the protective earth terminal, or the appropriate termination of the supply plug in the case of plug connected equipment. Omitting or disconnecting the equipment earth may cause a safety hazard.

The recommended minimum earth wire size is 2.5mm², unless otherwise stated in the technical data section of the product documentation.

Before energising the equipment, the following should be checked:

- Voltage rating, frequency and polarity
- VT ratio and phase sequence
- CT circuit rating and integrity of connections;
- Protective fuse rating;
- Integrity of earth connection (where applicable)
- Supply voltage
- External switch or circuit-breaker must be included in the installation for disconnection of the devices' auxiliary power supply. It must be suitably located and properly marked for reliable disconnection of the device when needed.

Important: A current transformer secondary should be shorted before connecting the transducer.

3. EQUIPMENT OPERATING CONDITIONS

The equipment should be operated within the specified electrical and environmental limits.

3.1 Current transformer circuits



Do not open the secondary circuit of a live CT since the high level voltage produced may be lethal to personnel and could damage insulation.

3.2 Insulation and dielectric strength testing



Insulation testing may leave capacitors charged up to a hazardous voltage. At the end of each part of the test, the voltage should be gradually reduced to zero, to discharge capacitors, before the test leads are disconnected.

3.3 Opening Enclosure



There are no customer replaceable PCB cards or components within the enclosure, so the enclosure should not be opened.

4. DECOMMISSIONING AND DISPOSAL



Decommissioning: The auxiliary supply circuit in the relay may include capacitors across the supply or to earth. To avoid electric shock or energy hazards, after completely isolating the supplies to the relay (both poles of any dc supply), the capacitors should be safely discharged via the external terminals prior to decommissioning.

Disposal: It is recommended that incineration and disposal to water courses is avoided. The product should be disposed of in a safe manner. Any products containing batteries should have them removed before disposal, taking precautions to avoid short circuits. Particular regulations within the country of operation, may apply to the disposal of lithium batteries.

5. TECHNICAL SPECIFICATIONS

5.1 Protective fuse rating

The recommended maximum rating of the external protective fuse for this equipment is 6A, Red Spot type or equivalent, unless otherwise stated in the technical data section of the product documentation.

Insulation class:	IEC 61010-1: 2001 Class II EN 61010-1: 2001 Class II	.
Insulation Category (Over voltage):	IEC 61010-1: 2001 Category III EN 61010-1: 2001 Category III	Distribution level, fixed installation. Equipment in this category is qualification tested at 5kV peak, 1.2/50 μ s, 500 Ω , 0.5J, between all supply circuits and earth and also between independent circuits.
Environment:	IEC 61010-1: 2001 Pollution degree 2 EN 61010-1: 2001 Pollution degree 2	Compliance is demonstrated by reference to generic safety standards.
Product Safety: 	2006/95/EC EN 61010-1: 2001	Compliance with the European Commission Low Voltage Directive. Compliance is demonstrated by reference to generic safety standards.

CONTENT

1.	SAFETY SECTION	1
1.1	Health and Safety	1
1.2	Explanation of symbols and labels	1
2.	INSTALLING, COMMISSIONING AND SERVICING	2
3.	EQUIPMENT OPERATING CONDITIONS	3
3.1	Current transformer circuits	3
3.2	Insulation and dielectric strength testing	3
3.3	Opening Enclosure	3
4.	DECOMMISSIONING AND DISPOSAL	3
5.	TECHNICAL SPECIFICATIONS	4
5.1	Protective fuse rating	4
1.	INTRODUCTION	9
1.1	General	9
1.2	KEY MESSAGES	9
1.3	ISTAT i4Mx Family	10
1.3.1	i4MT class 0.5 multifunction communicating Transducer.	10
1.3.2	Software:	10
1.4	Measurements	10
1.5	Hardware features	10
1.6	Communications	10
1.7	Inputs and Outputs	11
1.8	Applications	11
2.	HARDWARE	12
2.1	The Product	12
2.2	Mounting	12
2.3	Connections	12
2.4	Communications	12
2.4.1	RS232 or RS485 communications	12
2.4.2	USB communications	13
2.4.3	Communication connection details	13
2.5	Inputs and Outputs	14
2.5.1	Alarm (outputs)	14
2.5.2	Analogue (outputs)	14
2.5.3	Fast Response Analogue (outputs)	14
2.6	Auxiliary Supply	15
2.7	Measurement Inputs	15

3.	SETTINGS	16
3.1	Introduction	16
3.2	QDSP Software	16
3.2.1	Devices Management	16
3.2.2	Instrument settings	16
3.2.3	Real time measurements	16
3.2.4	Software upgrading	16
3.3	Setting Procedure	17
3.4	General Settings	17
3.4.1	Description and Location	17
3.4.2	Average Interval	17
3.4.3	Temperature Unit	17
3.4.4	Maximum Demand calculation (MD mode)	17
3.4.5	Starting Current for PF and PA (mA)	18
3.4.6	Starting current for all powers (mA)	18
3.4.7	Starting voltage for SYNC (V)	18
3.4.8	Reactive power calculation	18
3.5	Connection	18
3.5.1	Connection	19
3.5.2	Setting of current and voltage ratios	19
3.5.3	Used Voltage and Current Range	19
3.5.4	Nominal Frequency	20
3.5.5	CT connection	20
3.6	Communication	20
3.6.1	Serial Communication parameters (COM)	20
3.6.2	Modbus Table of Addresses	20
3.6.3	USB Communications	20
3.7	Security	20
3.7.1	Password setting	20
3.7.2	Password modification	20
3.8	Inputs and Outputs	21
3.8.1	Analogue output module	21
3.8.2	Alarm Output Module	22
3.9	Alarms	22
3.9.1	Alarm setting	22
3.10	Reset Operations	23
3.10.1	Reset MD values	23
3.10.2	Reset the last MD period	23
3.10.3	Reset alarm output	23
4.	SYSTEM MODES	24
4.1	Connection mode	24

4.1.1	Valid measurements	24
4.2	Power mode	26
<hr/>		
5.	INSTRUMENTATION	27
5.1	Measurements	27
5.2	Supported Measurements	28
5.2.1	Voltage	29
5.2.2	Current	29
5.2.3	Angles between Phases	29
5.2.4	Frequency	29
5.2.5	Harmonics(THD)	29
5.3	Power and power factor	29
5.3.1	Power	29
5.3.2	Power factor	29
5.3.3	Maximum demands (MDs)	29
5.3.4	Average demands	30
<hr/>		
6.	COMMUNICATIONS	31
6.1	Communications ports	31
6.2	QDSP Setting and Monitoring Software	31
6.3	MODBUS	31
<hr/>		
7.	TECHNICAL DATA	32
8.	WIRING DIAGRAMS	37
9.	RELATED DOCUMENTS	41
10.	APPENDIX A: MODBUS COMMUNICATION PROTOCOL	42
10.1	Actual Measurements	42
10.2	Register Table for IEEE 754 Measurements	44
10.3	Normalized Actual Measurements	46
10.4	100% values calculations for normalized measurements	49
10.5	Register table for the basic settings	50
10.6	Data types decoding	51
<hr/>		
11.	APPENDIX B: CALCULATIONS & EQUATIONS	53
11.1	Definitions of symbols	53
11.2	Equations	53

BLANK PAGE

1. INTRODUCTION

1.1 General

The **i4MT** is a multifunction transducer aimed at the medium voltage and industrial market segments throughout the world.

The **i4MT** offers:

- High accuracy measurements
- A cost-effective solution for Medium Voltage and Industrial markets
- Modbus protocol for integrating into energy management and control systems.
- Standard and Fast response analogue outputs
- CE certification

1.2 KEY MESSAGES

- The iSTAT **i4MT** provides Class 0.5 measurement of Volts, Current and Power
- The iSTAT **i4MT** is an **economical** choice for measurements that allows the user to tailor the output functions to the application.
- **i4MT** allows communication to MODBUS based systems that are widely used by industrial and utility customers worldwide.

ISTAT – **THE standard** measurement platform

- Multiple advanced configuration features fitted as standard.
- Comprehensive choice of features for measurement applications – to satisfy all metering, measurement and data recording and power quality applications
- Flexible programmable software (**QDSP**) allows off line and on line settings and data interpretation
- Complete and informative documentation, **QDSP** also includes help information.
- A choice of different input and output options.

Simple to install, **simple** to set, **simple** to connect

1.3 ISTAT i4Mx Family

The **i4Mx** family consists of 3-phase and single phase transducers all of which are 0.5% multifunction instruments. **This manual details the 3-phase transducer model i4MT.**

1.3.1 i4MT class 0.5 multifunction communicating Transducer.

The transducer is used for monitoring and measuring electric quantities of single or three-phase electrical power distribution systems. It measures RMS value by means of fast sampling of voltage and current signals, which makes the instrument suitable for acquisition of transient events. A built-in microcontroller calculates measurements (voltage, current, frequency, power, power factor, THD phase angles, etc.) from the measured signals.

The meter is provided with 16 program adjustable alarms, up to four output modules and communication. With USB (programming only) and RS232 or RS485 communication, the meter can be configured and measurements can be checked.

The **i4MT** can be used as a Power Meter for monitoring and measuring electrical parameters in a power system.

1.3.2 Software:

The same software is used for configuring the device as on all iSTAT communicating products.

- **QDSP Standard** for setting and browser software
- **QDSP** also offers additional features such as upgrading from a secure web site for both the **QDSP** software and the transducer firmware.

1.4 Measurements

The **i4MT** is ideally suited to applications where continuous monitoring of a single or three-phase system is required, particularly the local and remote indication for ac switchboard power measurements.

TABLE 1-1 has a summary of the measurements available. The **i4MT** can be user configured for either single or three phase connection.

TABLE 1-1: MEASUREMENTS
V, I, P, Q, S, PF, PA, F, φ
Maximum demand
THD

1.5 Hardware features

The **i4MT** has a Red LED indicator showing that power is on.

The **i4MT** has a universal auxiliary supply and an auto ranging current and voltage measurement input so that it can be used in most site conditions without the need to specify this information at the order stage.

1.6 Communications

The **i4MT** is supplied with either RS232 or RS485 communications via screw terminals, which has to be defined at the time of ordering. The communications are used for programming the transducer or for monitoring measurements.

In addition a USB port (mini type) is always provided on the underside of the **i4MT** for programming the transducer before installation. The USB port cannot be used when the **i4MT** is installed on the DIN Rail.

Note: The USB port has only Basic Insulation and can only be used when there is no wiring connected to the main terminals.

Note: The Cover over the USB connector must be fitted prior to installation or storage, if not the Warranty on the product will be void.

1.7 Inputs and Outputs

The **i4MT** has four I/O module positions, each of which can support an I/O module as shown in TABLE 1-2. Each module required is defined at the order stage.

TABLE 1-2: I/O OPTIONS	Quantity	Position	Specification
Analogue output	4 outputs	As defined by the cortec	Fully programmable +/- 20mA, +/- 10V
Fast Response Analogue output	4 outputs	As defined by the cortec	Fully programmable +/- 20mA, +/- 10V
Alarm output	4 outputs	As defined by the cortec	48 V AC/ VDC (+40% max), 1000mA max

1.8 Applications

Power Measurements: The **i4MT** provides a wide range of instantaneous analogue values; Voltage, current, Power, phase angle, power factor and frequency. These are available remotely via communications.

In addition the **i4MT** has 32 software alarms and 4 optional alarm relay outputs, for range checking and indication.

The **i4MT** therefore replaces a number of separate transducers and is ideally suited to ac switchboard applications.

2. HARDWARE

2.1 The Product

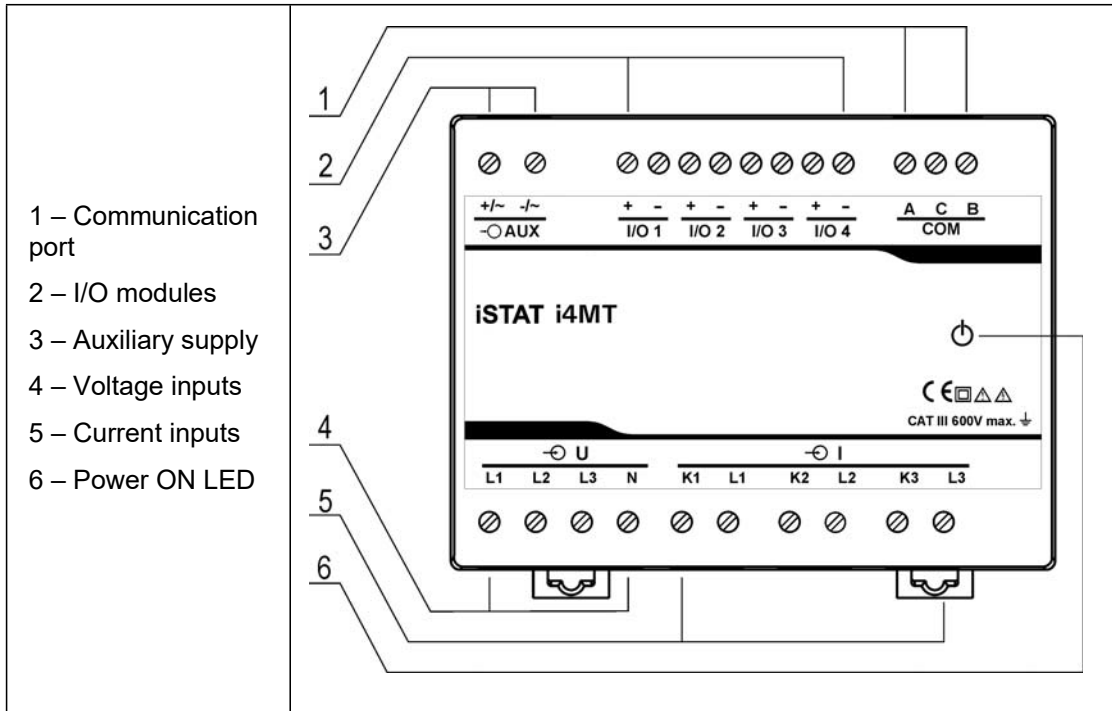

FIGURE 2-1: I4MT SHOWING CONNECTIONS

2.2 Mounting

The **i4MT** measuring transducer is designed for DIN rail mounting. It should be mounted on a 35 mm DIN rail by means of two plastic fasteners. Before installation the fasteners should be in open position (pulled). After the device is in place, the fasteners are locked (pushed) to closed position.

2.3 Connections

The use and connection of the **i4MT** involves the handling of dangerous currents and voltages. Only a qualified person should therefore perform the connection.

Before use: Check voltages and phase rotation, supply voltage and nominal frequency.

Check protective fuse rating (the recommended maximum rating of the external protective fuse for this equipment is 6A - Red Spot type or equivalent).

Warning: Wrong or incomplete connection of supply, measurement or other terminals can cause incorrect measurements, malfunction or damage to the device.

Note: After connection, settings have to be performed via communication (connection mode, current and voltage transformers ratio ...).

2.4 Communications

The **i4MT** can be supplied with RS232 or RS485 communications, which must be specified when ordering. The communication protocol available is Modbus RTU, which enables the remote viewing of measurements and the viewing and setting of system parameters.

2.4.1 RS232 or RS485 communications

The **i4MT** transducers can be supplied with either a RS232 or RS485 port (COM) via terminals.

Connection information for COM will be shown on a label as depicted in table 2-1.

The connection of RS232 communications is usually between the **i4MT** and a PC, the maximum connection length is 15 metres.

RS485 communications enables simultaneous connection to a maximum of 32 communicating devices; two-wire RS485 only is used. For RS485 communications, the PC will require either an internal RS485 communications port or an external RS232/RS485 or USB/RS485 interface. In both cases the device must provide automatic RS485 data flow control. The maximum connection length is 1000 metres. Conductors A and B should be terminated with a 120Ω terminating resistor on the units at each end of the RS485 network.

Connection Label	
	

TABLE 2-1: RS232 AND RS485 CONNECTIONS

2.4.2 USB communications

The **i4MT** transducer is always supplied with a USB port on the underside, under a removable plastic cover, for programming use only, using an USB type mini B connector. The i4Mx will be powered from the USB connection, allowing programming without any other wiring being connected.

Note: The USB port has only Basic Insulation and can only be used when there is no wiring connected to the main terminals.

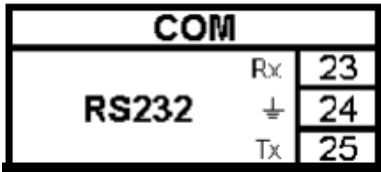
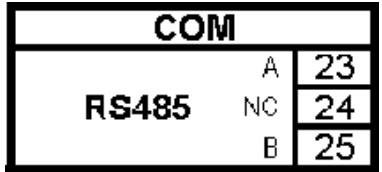
Note: The Cover over the USB connector must be fitted prior to installation or storage, if not the Warranty on the product will be void.

USB communication serves as a fast peer-to-terminal data link. The instrument is detected by the host as a USB 2.0 compatible device.

See the QDSP manual for details of how to set-up the USB connection.

2.4.3 Communication connection details

Connector	Terminals	Position	RS232	RS485
SCREW TERMINAL		23	Rx	A
		24	GND	NC
		25	Tx	B
USB-mini B		Standard USB 2.0 compatible cable recommended (Type mini B plug)		

TABLE 2-2: COMMUNICATIONS

2.5 Inputs and Outputs

The **i4MT** can be supplied with up to four hardware I/O modules which are fitted internally during manufacture and need to be specified when ordering. These modules can be factory fitted as one of the options shown in TABLE 2-3.

TABLE 2-3: I/O OPTIONS	Quantity	Position
Analogue output	4 outputs	As defined by cortec
Fast Response Analogue output	4 outputs	As defined by cortec
Alarm output	4 outputs	As defined by cortec

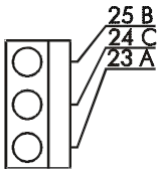
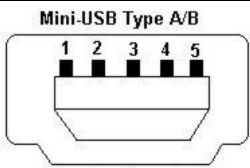
Since each hardware module is independent and isolated from any other, the **i4MT** can be supplied with any combination of outputs. The assignment of the output options to an I/O module position is done as defined by the cortec.

The terminal connections for the 4 I/O modules are shown in Figure 8-1.

2.5.1 Alarm (outputs)

The alarm contacts can be used for external monitoring of any alarm condition. The alarms can be set via the communications link.

The alarm module has two terminals (see TABLE 2-4), and the **i4MT** can provide a maximum of 4 independent outputs.

I/O 1	
Relay output	⊖→
48 V AC/DC +~	15
1000 mA -~	16

Alarm (relay) module. (Example of alarm module as I/O module 1)

TABLE 2-4: ALARM CONTACTS

2.5.2 Analogue (outputs)

The **i4MT** can be supplied with up to four independent analogue outputs, each of which can be set within the range $\pm 20\text{mA}$ or $\pm 10\text{V}$. The analogue output can be configured to represent any of the instantaneous measured values. The outputs can be set via the communications link.

The analogue module has two terminals (see TABLE 2-5).

I/O 1	
Analog output	⊖→
0...-/+20 mA +	15
0...-/+10 V -	16

Analogue output module with analogue output, proportional to measured quantities. The outputs may be either short or open-circuited. They are electrically insulated from each other and from all other circuits. (Example of analogue output module as I/O module 1)

TABLE 2-5: ANALOGUE OUTPUTS

2.5.3 Fast Response Analogue (outputs)

The **i4MT** can be supplied with up to four independent Fast response analogue outputs, each of which can be set within the range $\pm 20\text{mA}$ or $\pm 10\text{V}$. The analogue output can be configured to represent any of the instantaneous measured values. The outputs can be set via the communications link.

The analogue module has two terminals (see TABLE 2-6).

I/O 1	
Fast analog output	⊕→
0...+/-20 mA	+ 15
0...+/-10 V	- 16

Analogue output module with analogue output, proportional to measured quantities. The outputs may be either short or open-circuited. They are electrically insulated from each other and from all other circuits. (Example of analogue output module as I/O module 1)

TABLE 2-6: FAST ANALOGUE OUTPUTS

2.6 Auxiliary Supply

The **i4MT** Measuring transducer has a universal (AC/DC) auxiliary power supply. Connection details and ratings are shown on a label as detailed in TABLE 2-7.

AUX	
24...300 V DC	→⊙
40...276 V AC	+~L 13
45...65 Hz	
< 8 VA	-~N 14

Connection of universal power supply to terminals 13 and 14

TABLE 2-7: AUXILAIRY SUPPLY

NOTE: FOR SAFETY PURPOSES IT IS IMPORTANT THAT BOTH WIRES (LINE AND NEUTRAL) ARE FIRMLY CONNECTED. THEY SHOULD BE CONNECTED ONLY TO THE DESIGNATED TERMINALS AS SHOWN ON THE LABEL ABOVE AS WELL AS ON THE FRONT LABEL OF THE TRANSDUCER.

2.7 Measurement Inputs

The Voltage inputs of the **i4MT** can be connected directly to low-voltage networks or via an appropriate voltage transformer to medium or high voltage networks.

The Current inputs of the **i4MT** can be connected directly to low-voltage networks or via a current transformer.

The required connection type should be selected from the different wiring connections shown in section 8.

The **i4MT** has an auto-ranging voltage and current input with nominal values of 500V and 5A. Since the **i4MT** also has a fully configurable connection mode the default information is shown as 4u (three-phase 4 wire unbalanced) and the default connection diagram also shows this connection. This information is shown on the label as detailed in TABLE 2-8.

INPUTS
Current: 5A
Voltage: 500V
Frequency: 50, 60Hz
Connect.: 4u

TABLE 2-8: MEASUREMENT INPUTS

3. SETTINGS

3.1 Introduction

Instrument settings can be remotely modified with the QDSP software, when connected to a PC.

3.2 QDSP Software

QDSP is a software tool for complete monitoring of measuring instruments, connected to a PC via serial or USB communication. A user-friendly interface consists of five segments: devices management, instrument settings, real-time measurements, data analysis and software upgrading. The QDSP software is available free of charge.

A separate QDSP manual is available that defines the operation of QDSP in detail.

3.2.1 Devices Management

The communications parameters for any connected device can be modified. Also included are browsers which scan the communications networks attached to the PC and identify all of the devices connected with their addresses and communications parameters. This can be done on RS232, RS485 or USB (programming only) connections.

3.2.2 Instrument settings

The instrument settings are organized in a tree structure and they can be modified simply as required. In addition to transferring settings to the instrument, QDSP can also store the data to settings files and read it back when required.

3.2.3 Real time measurements

All measurements can be displayed in real time in a table.

If further processing of the measurement data is required it can be copied via a clipboard and inserted into standard Windows formats.

3.2.4 Software upgrading

It is suggested that the latest version of QDSP should always be used and if the system is also connected to the internet it will define if an upgrade is available for download.

3.3 Setting Procedure

In order to modify the settings with QDSP the current parameters must be loaded first. Instrument settings can be acquired via a communications link or they can be loaded off-line from a file on a local disk. The QDSP contains sample settings files for each product variant that can be downloaded to show the range of settings available for the specific product. These files can be modified and then stored under a different name allowing an instrument configuration to be generated off-line without an instrument attached, and downloaded at a later date.

Settings are displayed in the QDSP setting window, the left part displays a hierarchical tree structure of settings, the right hand part displays parameter values of the chosen setting group, see Figure 3-1.

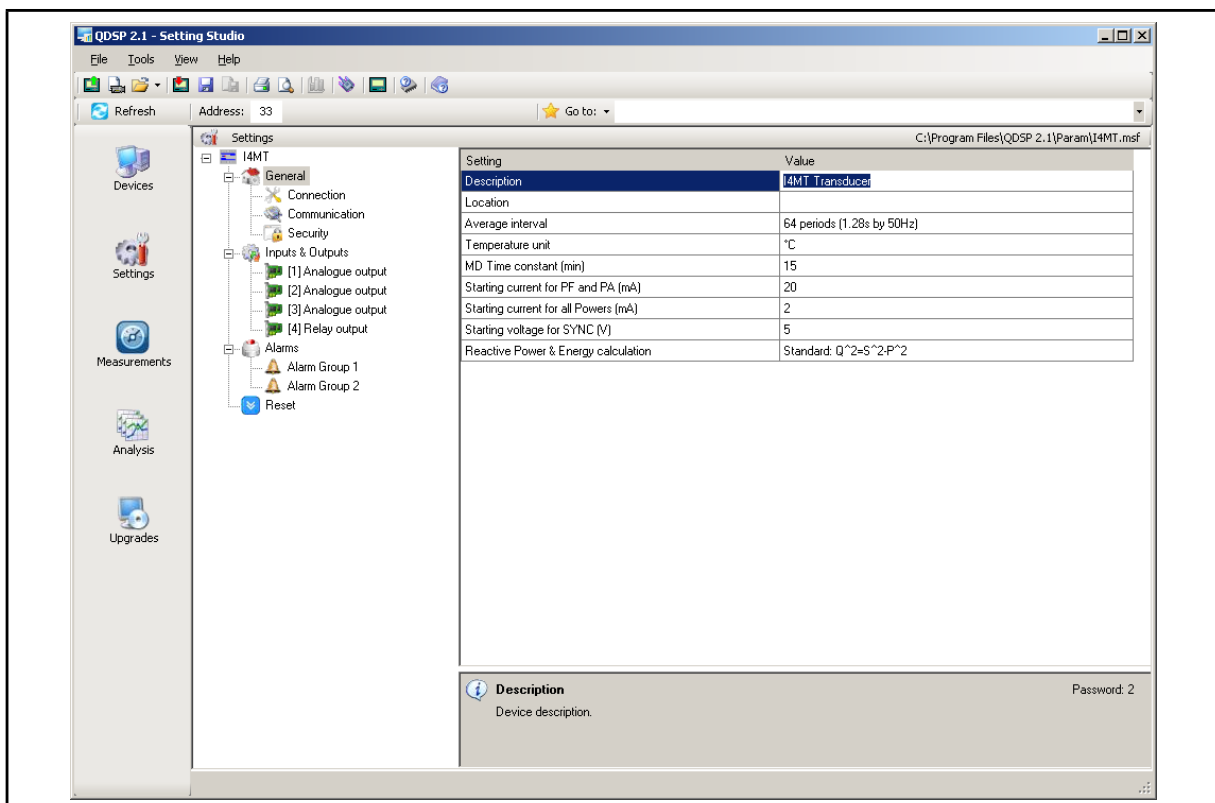

FIGURE 3-1: QDSP INTERFACE

3.4 General Settings

General Settings are essential for the operation of the measuring transducer. They are divided into three additional sublevels (Connection, Communication and Security).

3.4.1 Description and Location

These are two parameters that are extended for easier recognition of a particular instrument. They allow for the identification or location to be defined where measurements are performed.

3.4.2 Average Interval

The averaging interval defines the refresh rate of measurements for communications display.

3.4.3 Temperature Unit

Choose a unit for temperature values

3.4.4 Maximum Demand calculation (MD mode)

The **i4MT** provides maximum demand values using the Thermal function.

3.4.5 Starting Current for PF and PA (mA)

At all measuring inputs noise is usually present. It usually has consistent amplitude and its influence on the accuracy of the measurement increases as the amplitude of the signal to be measured decreases. It is also present when measuring signals are not connected and can give false readings for all subsequent calculations.

By setting a starting current for Total Power Factor and Power Angle, a minimum level is defined where the measurements and calculations commence, reducing the effect of any input noise.

3.4.6 Starting current for all powers (mA)

By setting a Minimum Starting Current, a level is defined where the measurements of Current and calculation of all powers commence, reducing the effect of any input noise.

3.4.7 Starting voltage for SYNC (V)

If all phase voltages are smaller than this (noise limit) setting, instrument uses current inputs for synchronization. If also all phase currents are smaller than *Starting current for PF and PA* setting, synchronization is not possible and frequency displayed is 0.

3.4.8 Reactive power calculation

Two different principles of reactive power and energy calculation are used:

Standard method:

With this method reactive power and energy are calculated based on assumption that all power (energy) that is not active is reactive.

$$Q^2 = S^2 - P^2$$

This means also that all higher harmonics will be measured as reactive power (energy).

Delayed current method:

With this method, reactive power (energy) is calculated by multiplication of voltage samples and delayed current samples.

$$Q = U \times I|_{+90^\circ}$$

With this method, reactive power (energy) represents only true reactive component of apparent power (energy).

3.5 Connection

The setting of the connection parameters must reflect the actual applications or the measurements will not be valid.

All of the settings in this section should be defined before the settings for the analogue and alarm outputs, as changes to this section may automatically change the measurements and output settings

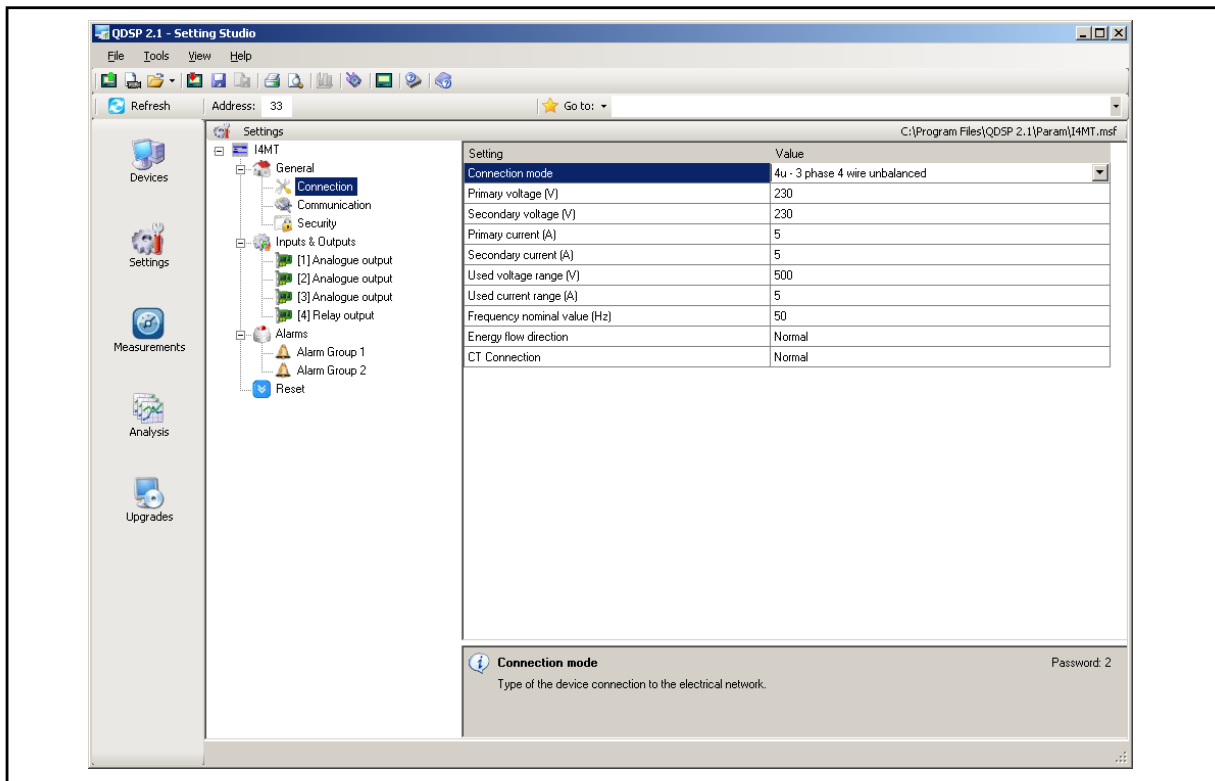

FIGURE 3-2: CONNECTION

3.5.1 Connection

When the connection is selected, the load connection and the supported measurements are defined (see section 4).

3.5.2 Setting of current and voltage ratios

The details of the application must be known to define these settings; all other measurements depend on them. Values with up to 5 numerical digits and a maximum of 3 decimal places can be input.

Settings range	VT primary	VT secondary	CT primary	CT secondary
Maximum value	1638,3 kV	13383 V	1638,3 kA	13383 A
Minimum value	0,1 V	1 mV	0,1 A	1 mA

3.5.3 Used Voltage and Current Range

The setting of this range is connected with the setting of all alarms and analogue outputs. Using a value that matches the expected measurement range (with overload) will achieve the highest quality of measurements.

If the 'Used' ranges are changed after the analogue or alarm settings have been defined, then the analogue and alarm settings will be modified automatically, as defined below. It may be necessary to modify the settings for the analogue and alarm outputs.

The 'Used' ranges are used to set the default scaling for the analogue output, which can be subsequently changed to meet the application requirements. Internally the analogue settings are also stored as a percentage of the 'Used' ranges. If the 'Used' ranges are subsequently changed the analogue output settings will be correspondingly changed to maintain the settings as the same percentage of the 'Used' range.

Although the alarm settings are defined in real values on QDSP, the alarms are also calculated as a percentage of the 'Used' range. If the 'Used' ranges are subsequently changed the alarm settings will be correspondingly changed to maintain the settings as the same percentage of the 'Used' range.

3.5.4 Nominal Frequency

A valid frequency measurement is within $\pm 32\text{Hz}$ of the nominal frequency. This setting is only used for alarms.

3.5.5 CT connection

If this setting is set to REVERSED it has the same effect as if the CT's were connected in reverse. The sign of all power readings will also change.

3.6 Communication

The settings displayed depend on the hardware options on the specific instrument connected or the settings in the specific settings file that is being worked on off-line.

3.6.1 Serial Communication parameters (COM)

These parameters are important for the correct operation in RS485 networks or connections with PC via RS232 communications. Factory settings for communication are #33\19200 (or 115200),n,8,2 (address 1 to 247\data rate 2400 to 115200 b/s, parity, data bits, stop bit).

3.6.2 Modbus Table of Addresses

With this setting a MODBUS table for measurements and settings is defined. MODBUS addresses for measurements and settings can be compatible with the previous family of transducers (i400) or with the more advanced family of transducers (i5Mx).

3.6.3 USB Communications

The transducer will be identified as a USB device when connected to a USB port on the PC, refer to the separate QDSP manual for details of the driver installation and QDSP operation.

Note: The USB port has only Basic Insulation and can only be used when there is no wiring connected to the main terminals.

Note: The Cover over the USB connector must be fitted prior to installation or storage, if not the Warranty on the product will be void.

3.7 Security

Parameter settings are divided into 2 groups regarding security level:

1. If the passwords are set to 'AAAA' (default) there is no restriction to the access of parameter settings.
2. At the first level (PL1), the settings for MD can be accessed.
3. At the second level (PL2), access is given to all parameter settings.
4. A Backup password (BP) is used if the passwords at level 1 (PL1) and level2 (PL2) have been forgotten, and it differs for each device depending on the serial number of the instrument. The BP password is available from Technical Support and is entered instead of password PL1 and/or PL2. The serial number is stated on the product label or can be read with QDSP and must be supplied when requesting the BP.

3.7.1 Password setting

A password consists of four capital letters taken from the British alphabet from A to Z. When setting a password, only the letter being set is visible, while the others are covered with an asterisk.

Two passwords (PL1, PL2) and the time after which they become active, can be set.

3.7.2 Password modification

A password can be modified; however only the password whose access has been unlocked (password entered) can be modified.

To disable a password previously set, modify the password back to 'AAAA'.

3.8 Inputs and Outputs

The module settings displayed will depend on the I/O modules built in to the instrument or defined in the settings file if working off-line.

3.8.1 Analogue output module

Each of up to four analogue outputs is fully programmable. The settings for both the Standard and Fast Analogue options are the same and both modules are shown as an 'Analogue output'. The only difference with the Fast Analogue is its faster response time (≤ 50 ms), and consequentially higher ripple.

3.8.1.1 Output parameter

Define the Measured or calculated parameter that is to be output on the specific analogue output.

3.8.1.2 Output range

The analogue output can be configured to one of six hardware output ranges within which the analogue output will operate. To ensure the highest accuracy for the output, the range selected should be the lowest that covers the required analogue output range.

DC current output	DC voltage output
-1...0...1 mA	-1...0...1 V
-5...0...5 mA	
-10...0...10 mA	-10...0...10 V
-20...0...20 mA	

3.8.1.3 Output Signal

This defines the actual range and output curve shape of the required analogue signal. Up to 5 break points can be programmed to achieve the required curve.

The screenshot shows the 'QDSP 2.1 - Setting Studio' interface. The left sidebar contains a tree view of settings, with 'Inputs & Outputs' expanded to show four analogue outputs. The main window displays a table of settings for the selected output:

Setting	Value
Output parameter	Voltage U1
Output range	20 mA
Output signal	Linear
Average interval for analogue output	1 period (0.02s by 50Hz)

The 'Output signal' dialog box is open, showing the following configuration:

- Parameter: Voltage U1
- Signal form: Linear
- Table of V vs mA values:

V	mA
-500.0	-20.000
-350.0	0.000
0.0	8.000
400.0	12.000
500.0	20.000
- Graph showing a linear relationship between V and mA.
- Buttons: Edit, Remove, Predefined profiles, OK, Cancel.

At the bottom of the dialog box, there is a description: 'Output signal Defines the output signal form and optional breakpoints of the analogue output. Password: 2'.

FIGURE 3-7: ANALOGUE OUTPUT SETTINGS

If the Analogue output signal is modified from the full linear range, the accuracy of the output may be reduced due to the reduction in the overall output range.

Note: If the 'Used' ranges are changed after the analogue settings have been defined, then the analogue settings will be modified automatically, see section 3.5.3. It may be necessary to subsequently modify the settings for the analogue outputs.

3.8.1.4 Average interval for analogue output

Defines the time interval over which the measurement used for an analogue output will be averaged.

For correct operation of the Fast analog output module (fast response), average interval shall be set to minimum (1 period).

3.8.2 Alarm Output Module

Alarm groups that are connected with an alarm module and a signal shape are defined

An alarm module can also function as a general purpose digital output.

3.8.2.1 Output signal

The alarm/digital output can be configured for a number of different signal shapes:

- Normal – The relay is closed until the alarm condition is fulfilled.
- Normal Inverse – The relay is open until the alarm condition is fulfilled.
- Holds – The relay is closed when the alarm condition is fulfilled, and remains closed until it is reset via communication.
- Pulse – an impulse of the defined length is sent when the alarm condition is fulfilled.
- Always switched ON / OFF – The relay is switched ON or OFF irrespective of the alarm condition. This enables remote control via communication to be implemented.

3.8.2.2 General purpose digital output

This functionality allows the user to enable / disable output relay by software settings (when appropriate values are set in MODBUS table).

MODULE NUMBER	MODBUS REGISTER	REGISTER VALUE	
Module 1 (if installed)	40722	3 - ON	4 - OFF
Module 2 (if installed)	40725	3 - ON	4 - OFF
Module 3 (if installed)	40728	3 - ON	4 - OFF
Module 4 (if installed)	40731	3 - ON	4 - OFF

3.9 Alarms

There are 32 alarms available split into 4 alarm groups. .

3.9.1 Alarm setting

For each of the 4 alarm groups a time constant of maximum values in thermal mode, a delay on time and alarm deactivation hysteresis can be defined.

For each individual alarm a parameter, value (actual value or MD- thermal) and the condition for alarm switching are defined.

Note: If the 'Used' ranges are changed after the alarm settings have been defined, then the alarm settings will be modified automatically, see section 3.5.3. It may be necessary to subsequently modify the settings for the alarm outputs.

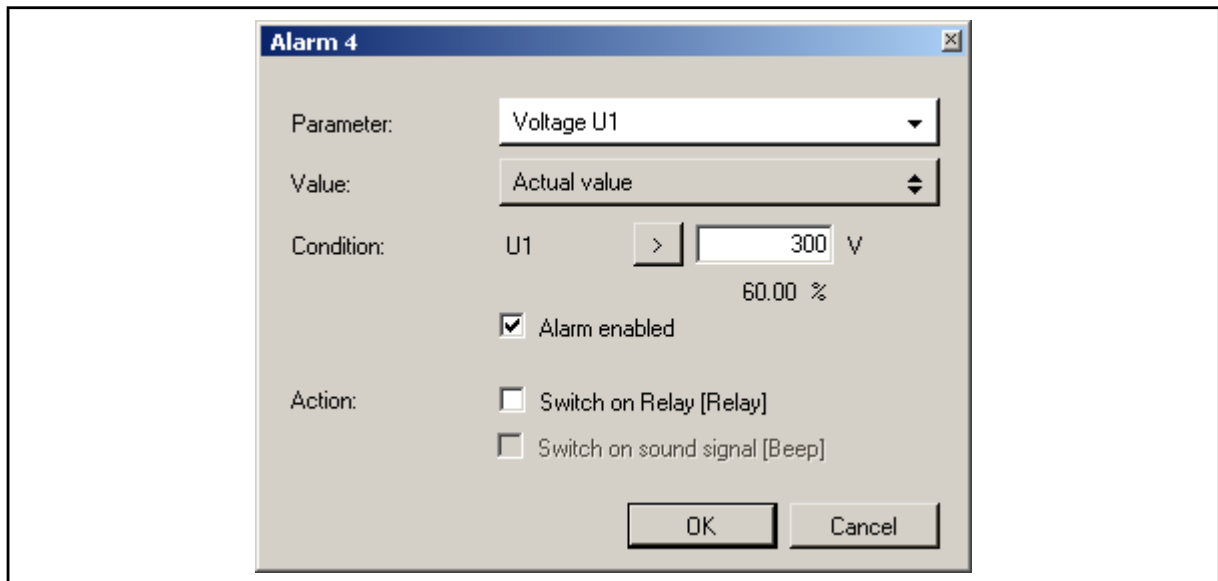

FIGURE 3-8: ALARM SETTINGS

3.10 Reset Operations

3.10.1 Reset MD values

Current and stored MD's are reset.

3.10.2 Reset the last MD period

Current MD value is reset.

3.10.3 Reset alarm output

All alarm outputs are reset.

4. SYSTEM MODES

4.1 Connection mode

The connection mode of the **i4MT** is configurable. The following options are available:

- 1b - single phase connection,
- 3b - three-phase, three-wire connection with balanced load,
- 4b - three-phase, four-wire connection with balanced load,
- 3u - three-phase, three-wire connection with unbalanced load
- 4u - three-phase, four-wire connection with unbalanced load.

4.1.1 Valid measurements

The following tables list the valid measurements for each connection type.

Key: ● – measured, ○ – calculated, × – not supported

	TABLE 4-1: BASIC MEASUREMENTS	Parameter	Unit	Connection				
				1b	3b	3u	4b	4u
Phase	Voltage U_1	U1	V	●	×	×	●	●
	Voltage U_2	U2	V	×	×	×	○	●
	Voltage U_3	U3	V	×	×	×	○	●
	Average voltage U^{\sim}	U_{λ}	V	×	×	×	○	●
	Current I_1	I1	A	●	●	●	●	●
	Current I_2	I2	A	×	○	●	○	●
	Current I_3	I3	A	×	○	●	○	●
	Current I_n	I_n	A	×	○	○	○	●
	Total current I_t	I	A	●	○	○	○	●
	Average current I_a	I_{avg}	A	×	○	○	○	●
	Active power P_1	P1	W	●	×	×	●	●
	Active power P_2	P2	W	×	×	×	○	●
	Active power P_3	P3	W	×	×	×	○	●
	Total active power P_t	P	W	●	●	●	○	●
	Reactive power Q_1	Q1	var	●	×	×	●	●
	Reactive power Q_2	Q2	var	×	×	×	○	●
	Reactive power Q_3	Q3	var	×	×	×	○	●
Total reactive power Q_t	Q	var	●	●	●	○	●	

	TABLE 4-2: BASIC MEASUREMENTS	Parameter	Unit	Connection Type				
				1b	3b	3u	4b	4u
Phase	Apparent power S_1	S1	VA	●	×	×	●	●
	Apparent power S_2	S2	VA	×	×	×	○	●
	Apparent power S_3	S3	VA	×	×	×	○	●
	Total apparent power S_t	S	VA	●	●	●	○	●
	Power factor PF_1	PF1/ePF1		●	×	×	●	●
	Power factor PF_2	PF2/ePF2		×	×	×	○	●
	Power factor PF_3	PF3/ePF3		×	×	×	○	●
	Total power factor PF^{\sim}	PF/ePF		●	●	●	○	●
	Power angle φ_1	φ_1	°	●	×	×	●	●
	Power angle φ_2	φ_2	°	×	×	×	○	●
	Power angle φ_3	φ_3	°	×	×	×	○	●
	Total power angle φ^{\sim}	φ	°	●	●	●	○	●
	THD of phase voltage U_{f1}	U1%	%THD	●	×	×	●	●
	THD of phase voltage U_{f2}	U2%	%THD	×	×	×	○	●
	THD of phase voltage U_{f3}	U3%	%THD	×	×	×	○	●
	THD of phase current I_1	I1%	%THD	●	●	●	●	●
THD of phase current I_2	I2%	%THD	×	○	●	○	●	
THD of phase current I_3	I3%	%THD	×	○	●	○	●	
Phase-to-phase	Phase-to-phase voltage U_{12}	U12	V	×	●	●	○	●
	Phase-to-phase voltage U_{23}	U23	V	×	●	●	○	●
	Phase-to-phase voltage U_{31}	U31	V	×	●	●	○	●
	Average phase-to-phase voltage (U_{ff})	U_{Δ}	V	×	●	●	○	●
	Phase-to-phase angle φ_{12}	φ_{12}	°	×	×	×	○	●
	Phase-to-phase angle φ_{23}	φ_{23}	°	×	×	×	○	●
	Phase-to-phase angle φ_{31}	φ_{31}	°	×	×	×	○	●
	Voltage unbalance U_u	U_u	%	×	●	●	×	●
	THD of phase-to-phase voltage $THD_{U_{12}}$	U12%	%THD	×	●	●	○	●
	THD of phase-to-phase voltage $THD_{U_{23}}$	U23%	%THD	×	●	●	○	●
THD of phase-to-phase voltage $THD_{U_{31}}$	U31%	%THD	×	●	●	○	●	

	TABLE 4-2: BASIC MEASUREMENTS	Parameter	Unit	Connection Type				
				1b	3b	3u	4b	4u
Max. values MD	MD current I ₁	I1	A	●	●	●	●	●
	MD current I ₂	I2	A	×	○	●	○	●
	MD current I ₃	I3	A	×	○	●	○	●
	MD active power P (positive)	P+	W	●	●	●	●	●
	MD active power P (negative)	P-	W	●	●	●	●	●
	MD reactive power Q-L	Q _≡	var	●	●	●	●	●
	MD reactive power Q-C	Q _≠	var	●	●	●	●	●
	MD apparent power S	S	VA	●	●	●	●	●

Key: ● – measured, ○ – calculated, × – not supported

NOTE: For 3b and 3u connection mode, only phase-to-phase voltages are measured. Because of that, factor $\sqrt{3}$ is applied to calculation of quality considering nominal phase voltage.
For 4u connection mode measurements support is same as for 1b.

4.2 Power mode

The power mode is used for the signing of power measurements. The user cannot set the i4MT power mode. It is defined as follows:

- A positive sign indicates export power (a consumer) whilst a negative sign indicates import power (a generator).

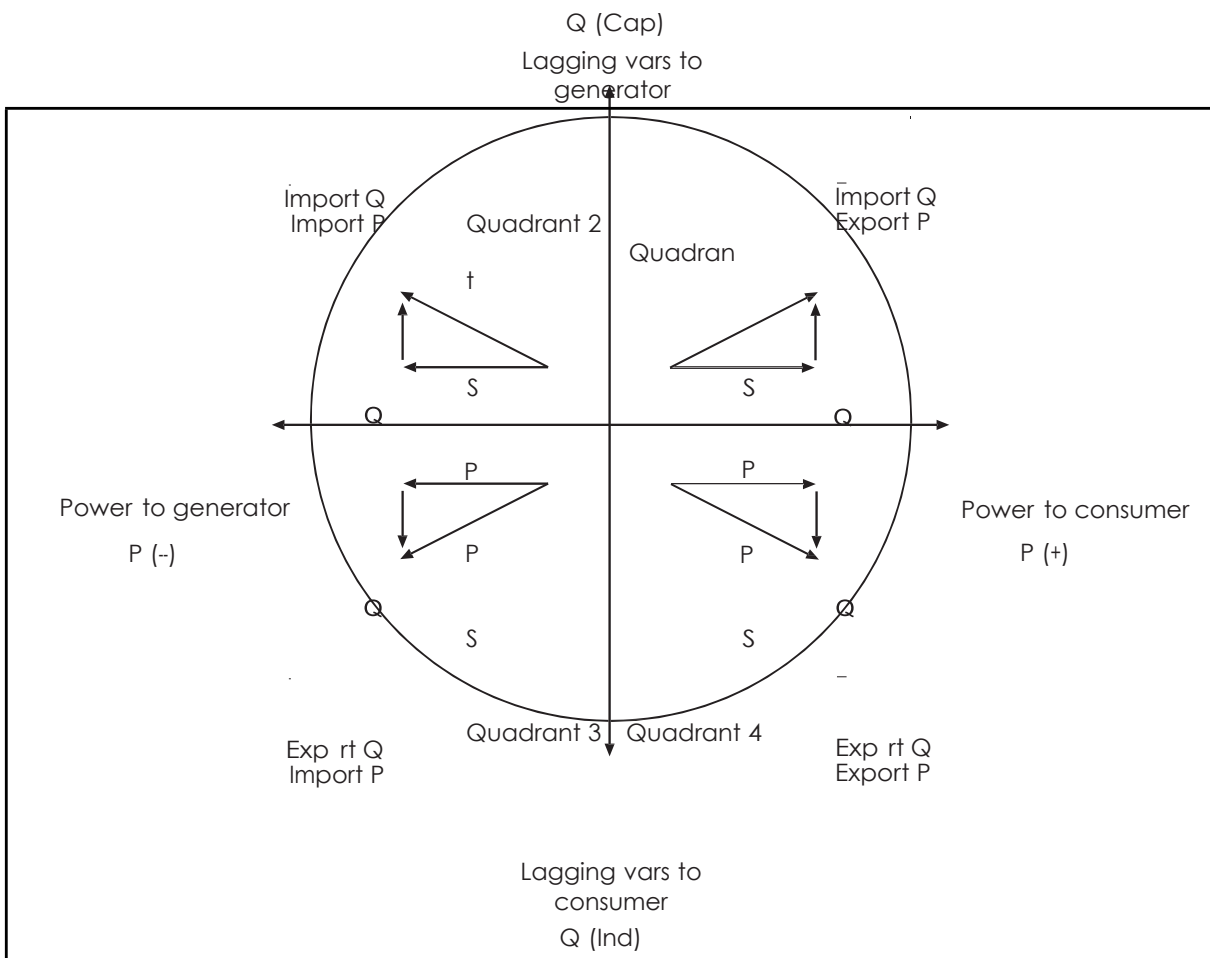

FIGURE 4-1: POWER FLOW

5. INSTRUMENTATION

5.1 Measurements

With the increase in harmonics present in today's power systems, due to the increased use of electronic loads such as computers, variable frequency drives, etc. it is important, when accurate monitoring of electrical parameters is required, to use a measuring technique that allows for their presence. Conventional measurement methods, that use a mean sensing technique, respond to the mean or average of the input waveform. This is only accurate

The following terms and symbols are used:

TABLE 5-1: SYMBOLS	
M _v	Sample factor
M _P	Averaging interval
U _f	Phase voltage (U ₁ , U ₂ or U ₃)
U _{ff}	Phase-to-phase voltage (U ₁₂ , U ₂₃ or U ₃₁)
N	Total number of samples in a period
n	Sample number (0 ≤ n ≤ N)
x, y	Phase number (1, 2 or 3)
i _n	Current sample n
u _{fn}	Phase voltage sample n
u _{ffn}	Phase-to-phase voltage sample n
φ _f	Power angle between current and phase voltage f (φ ₁ , φ ₂ or φ ₃)
U _u	Voltage unbalance
U _c	Agreed supply voltage

TABLE 5-2: GLOSSARY	
Term	Explanation
RMS	Root Mean Square value
Flash	Type of a memory module that keeps its content in case of power supply failure
MODBUS	Industrial protocol for data transmission
QDSP	Software for iSTAT family
AC	Alternating current
PA	Power angle (angle between current and voltage)
PF	Power factor
THD	Total harmonic distortion
MD	Measurement of average values in time interval

(maximum demand)	
Hand-over place	Connection spot of consumer installation in public network
Sample factor (Mv)	Defines a number of periods for measuring calculation on the basis of measured frequency
Averaging interval (Mp)	Defines frequency of refreshing displayed measurements on the basis of a Sample factor

5.2 Supported Measurements

The following table shows the measurements available on the **i4MT**; all values are available over the communications

TABLE 5-3: BASIC MEASUREMENTS	
Phase	Voltage U_1, U_2, U_3 in \tilde{U}
	Current I_1, I_2, I_3, I_n, I_t in I_{avg}
	Active power $P_1, P_2, P_3,$ and P_t
	Reactive power $Q_1, Q_2, Q_3,$ and Q_t
	Apparent power $S_1, S_2, S_3,$ and S_t
	Power factor PF_1, PF_2, PF_3 and $PF_{\tilde{}}$
	Power angle $\varphi_1, \varphi_2, \varphi_3$ and $\tilde{\varphi}$
	THD of phase voltage U_{f1}, U_{f2} and U_{f3}
Phase-to-phase	THD of power angle I_1, I_2 and I_3
	Phase-to-phase voltage U_{12}, U_{23}, U_{31}
	Average phase-to-phase voltage U_{ff}
	Phase-to-phase angle $\varphi_{12}, \varphi_{23}, \varphi_{31}$
	THD of phase-to-phase voltage
Maximal values MD	
	Phase current I_1
	Phase current I_2
	Phase current I_3
	Active power P (Positive)
	Active power P (Negative)
	Reactive power Q - L
	Reactive power Q - C
Apparent power S	
Other	Frequency
	Internal temperature

The equations defining the calculated values are detailed in Appendix B

5.2.1 Voltage

All versions of the **i4MT** except for the 3-phase 3-wire versions, measure the true RMS value of the phase voltages (U_1, U_2, U_3) connected to the unit. The three line voltages (U_{12}, U_{23}, U_{31}), average phase voltage (U_f) and average line voltage (U_Δ) are calculated from these measured parameters. For 3-phase 3-wire balanced systems, the **i4MT** creates a virtual neutral internally.

The 3-phase 3-wire versions of the **i4MT** measure the true RMS value of the phase to phase voltage.

5.2.2 Current

The **i4MT** measures the true RMS value of the phase currents (I_a, I_b, I_c) connected to the unit. The neutral current (I_n), the average of all phase currents and the sum of all phase currents (I_t) are calculated from the three phase currents.

5.2.3 Angles between Phases

Angles between phases indicate the angles between the vectors of phase voltages. A positive mark indicates correct phase sequence, while a negative mark indicates an opposite phase sequence of the measured system.

5.2.4 Frequency

The system frequency is calculated from the time period of the measured voltage.

5.2.5 Harmonics(THD)

The percentage total harmonic distortion (%THD) value is the ratio of the sum of the powers of the harmonic frequencies above the fundamental frequency to the power of the fundamental frequency. This sum of the powers is a geometric total, formed by taking the square root of the sum of the squares of the amplitude of each of the harmonics.

The **i4MT** measures true RMS values that ensure exact measurements with the presence of high harmonics up to 31st harmonic.

The **i4MT** provides %THD values for each phase current, each phase voltage, and for the line voltages.

5.3 Power and power factor

5.3.1 Power

The **i4MT** provides accurate measurement of active (P_a, P_b, P_c, P_t), reactive (Q_a, Q_b, Q_c, Q_t) and apparent power (S_a, S_b, S_c, S_t). For a four-wire system the powers are calculated both for each phase separately and as a total. For a three-wire system only total power values are measured.

Power direction

When displaying active power, a positive sign indicates export power (a consumer) whilst a negative sign indicates import power (a generator).

5.3.2 Power factor

The power factor is calculated as a quotient of active and apparent power for each phase separately ($\cos\phi_1, \cos\phi_2, \cos\phi_3$) and as a total ($\cos\phi_t$). A positive sign and a coil symbol denotes an inductive load (a consumer) whilst a negative sign and a capacitor symbol defines a capacitive load (a generator).

5.3.3 Maximum demands (MDs)

The **i4MT** stores the maximum demand value since last reset. The unit also provides the present or 'dynamic' maximum demand.

5.3.4 Average demands

5.3.4.1 Thermal Demand

The thermal demand option will provide an exponential thermal characteristic, based on the bimetal element principal. Maximum demand is stored in the unit.

A time constant (t. c.) can be set from 1 to 255 minutes and is 6-time thermal time constant (t.c. = 6 * thermal time constant).

Example:

Mode: Thermal function

Time constant: 8 min.

Current MD and maximal MD: Reset at 0 min.

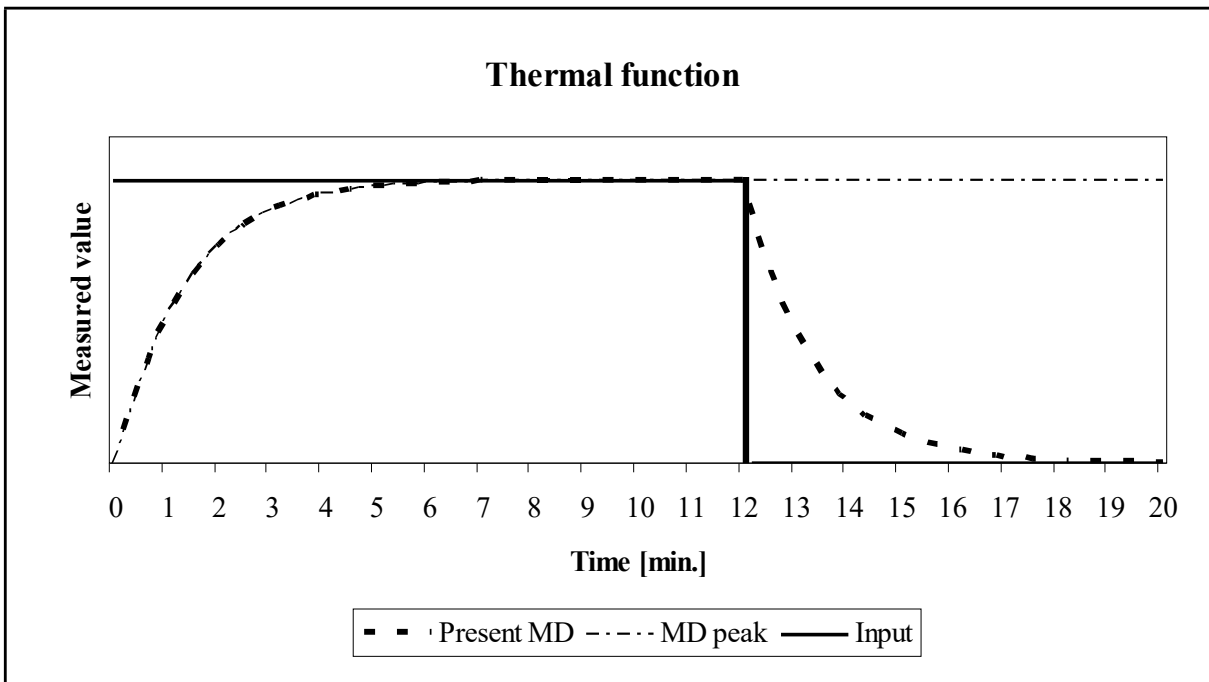

6. COMMUNICATIONS

6.1 Communications ports

The **i4MT** is fitted with a primary communications (COM) port

COM1 can be RS232 or RS485

The communications port can be used for settings and the monitoring of data.

The communication parameters of the **i4MT** can be obtained by using the 'Scan the network' feature in the QDSP setting software.

6.2 QDSP Setting and Monitoring Software

See the separate QDSP Manual for details of how to Install and use the QDSP Software.

6.3 MODBUS

Two versions of MODBUS register tables are available:

1: Compatibility with advanced family of transducers (i500)

2: Compatibility with previous family of transducers (i400) or new on i4MT

For details, see Appendix A

7. TECHNICAL DATA

INPUTS AND SUPPLY		
Voltage Input	Nominal voltage (Un)	230 V _{LN} , 415 V _{LL}
	Rating	45/230 V _{LN} 78/415 V _{LL}
	Max. allowed value	277 V _{LN} , 480 V _{LL} permanently 2 x Un for 10 seconds
	Minimum range	2 V sinusoidal
	Burden	$< U^2 / 3.3 \text{ M}\Omega$ per phase
Current Input	Nominal current (In)	5A
	Rating	1A/5A/10A (Auto-Range)
	Overload (thermal) (acc. to IEC/EN 60 688)	15A continuously $20 \times I_N ; 5 \times 1\text{s}$
	Minimal range	Set Starting current for power in QDSP
	Maximum range	12.5A sinusoidal
	Burden	$< I^2 \times 0.01\Omega$ per phase
Frequency	Nominal Frequency (Fn)	50, 60, 400Hz
	Measuring range	16 to 400Hz For frequency measurement only
Power Supply Universal		
	AC voltage range	40 to 276Vac
	Frequency range	45 to 65Hz
	DC voltage range	24 to 300Vdc
	Burden	<8VA
	Power on transient current	< 20A 1ms

CONNECTIONS	
Permitted conductor cross sections	Conductor cross section
Voltage terminals	0.325 ... 2.5 mm ² (22 – 14 AWG) one conductor
Current terminals	0.325 ... 2.5 mm ² (22 – 14 AWG) one conductor
Supply	0.325 ... 2.5 mm ² (22 – 14 AWG) one conductor
I/O Modules and Communications	0.325 ... 2.5 mm ² (22 – 14 AWG) one conductor

ACCURACY		
RMS Current ($I_1, I_2, I_3, I_{avg}, I_n$)	1A	0.3 (0.20**)
	5A	0.3 (0.20**)
RMS Line Voltage (U_1, U_2, U_3, U_{avg})	62.5V, 125V L-N	0.3 (0.20**)
	250V L-N	0.3 (0.20**)
	500V L-N	0.3 (0.20**)
RMS Phase-Phase Voltage ($U_{12}, U_{23}, U_{31}, U_{avg}$)	120V L-L	0.3 (0.20**)
	400V L-L	0.3 (0.20**)
	800V L-L	0.3 (0.20**)
Frequency		
Frequency (actual)	50/60 Hz	10 mHz (2 mHz**)
Nominal Frequency Range	16...400 Hz	10 mHz
Power Angle	-180...0...180°	0.2°
Power Factor	-1...0...+1	
	U = 50 ... 120 % U_n	0.5
	I = 2 % ... 20 % I_n I = 20 % ... 200 % I_n	0.2
THD	5 to 500V	0.5
	0 to 400%	0.5
Power		
Active W	Calculated from U and I	0.5 (0.30**)
Reactive VAR: Q Apparent VA : S	Calculated from U and I	0.5 (0.30**)

Total accuracy (measurements and analogue output) according to IEC/EN 60688. Accuracy is defined as percentage of reading of the measurement except when it is stated as an absolute value.

(** - accuracy on communication)

I/O MODULES		
Relay output	Contact rating	48 Vac/dc (+40% max)
	Maximum switching current	1000 mA
	Contact resistance	$\leq 100\text{m}\Omega$ (100mA, 24V)
	Insulation	1000V ac between open contacts
		4000V ac between coil and contacts

ANALOGUE		
General	Linearization	Linear, Quadratic
	No. of break points	5
	Output value limits	$\pm 120\%$ of nominal output
	Response time	Input \rightarrow output < 100ms (standard) $\leq 50\text{ms}$ (Fast analogue)
	Residual ripple	< 1 % p.p. (standard output) < 2 % p.p. (Fast analogue)
DC Current output	Output range values	-100...0...100%
	-1...0...1 mA	Range 1
	-5...0...5 mA	Range 2
	-10...0...10 mA	Range 3
	-20...0...20 mA	Range 4
	Other ranges	Programmable using QDSP
	Burden voltage	10 V
	External resistance	$R_{B_{\max}} = 10 \text{ V} / I_{\text{outN}}$
DC Voltage output	Output range values	-100...0...100%
	-1...0...1 V	Range 5
	-10...0...10 V	Range 6
	Other ranges	Programmable using QDSP
	Burden current	20 mA
	External resistance	$R_{B_{\min}} = U_{\text{outN}} / 20 \text{ mA}$

COMMUNICATION			
	RS232	RS485	USB
Type of connection	Direct	Network	Direct
Max. connection length	3 m	1000 m	3 m
Number of bus stations	-	≤ 32	-
Terminals	Screw terminals		USB-mini
Insulation	Protection class I, 3.3 kV _{ACRMS} 1 min		Basic Isolation only
Transfer mode	Asynchronous		
Protocol	MODBUS RTU		
Transfer rate	2.400 to 115.200 bit/s		USB 2.0

ELECTRONIC FEATURES		
Response time	Input to communications	Calculated during averaging interval setting (8 to 256 periods), resetting (64 periods) typically 1.28 seconds at 50Hz
Status LED		
PWR	Red	Instrument power ON

SAFETY FEATURES	
Protection	Protection Class II
Installation category	CAT III: 600V _{rms} , Measurement Inputs CAT III: 300V _{rms} , Auxiliary Supply In compliance with EN61010-1:2001
Pollution degree	2
Test voltage	U _{AUX↔I/O} , COM1,2: 3320 VAC _{rms} U _{AUX↔U} , I inputs: 3320 VAC _{rms} U, I inputs↔I/O, COM1,2: 3320 VAC _{rms} U inputs↔I inputs: 3320 VAC _{rms}
EMC	Directive on electromagnetic compatibility 2004/108/EC According to EN61326-1
Protection	In compliance with EN60529:1997 IP20

AMBIENT CONDITIONS	
Climatic	Usage group III
Ambient Temperature	-10...0...45...55°C Acc. To IEC/EN 60688
Temperature	Operation -30 to +70C Storage -40 to +70C
Humidity	≤ 93%RH non condensing
Altitude	≤ 2000 m

MECHANICAL	
Dimensions	W100 × H75× D105 mm
Max. conductor cross section for terminals	2,5 mm ² with pin terminal 4 mm ² solid wire
Vibration withstand	7g, 3...100 Hz, 1 oct/min 10 cycles in each of three axes
Shock withstand	300g, 8ms pulse 6 shocks in each of three axes
Mounting	Rail mounting 35 × 15 mm acc. to DIN EN 50 022
Enclosure material	PC/ABS
Flammability	Acc. to UL 94 V-0
Weight	370 g

8. WIRING DIAGRAMS

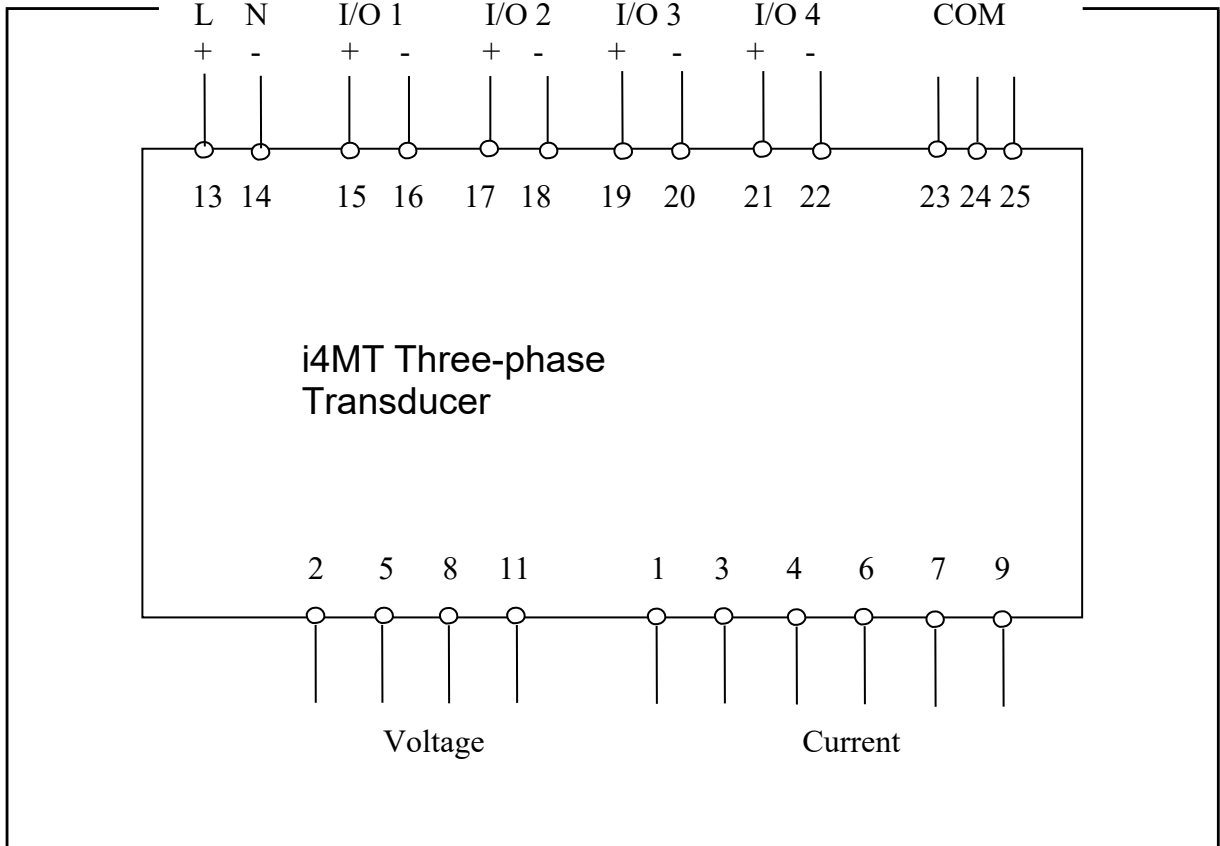

FIGURE 10-1: CONNECTION DIAGRAM

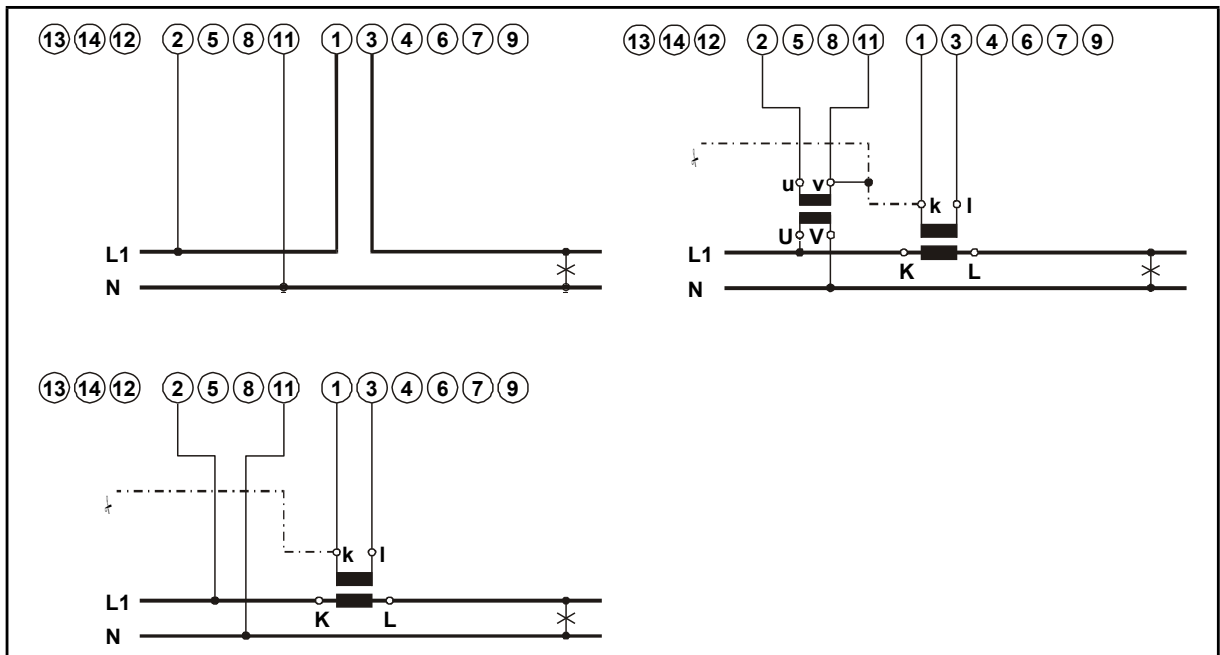

FIGURE 10-2: EXTERNAL WIRING DIAGRAM: SINGLE PHASE (1B)

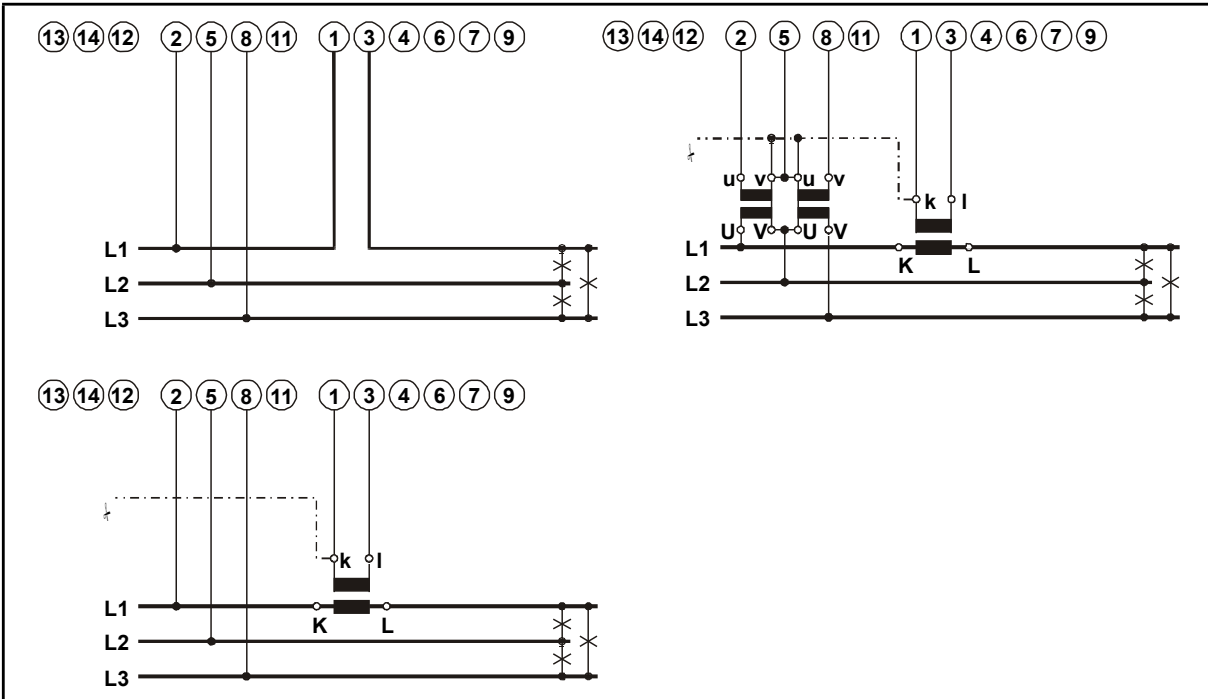

FIGURE 10-3: EXTERNAL WIRING DIAGRAM: 3-PHASE, 3-WIRE BALANCED LOAD (3B)

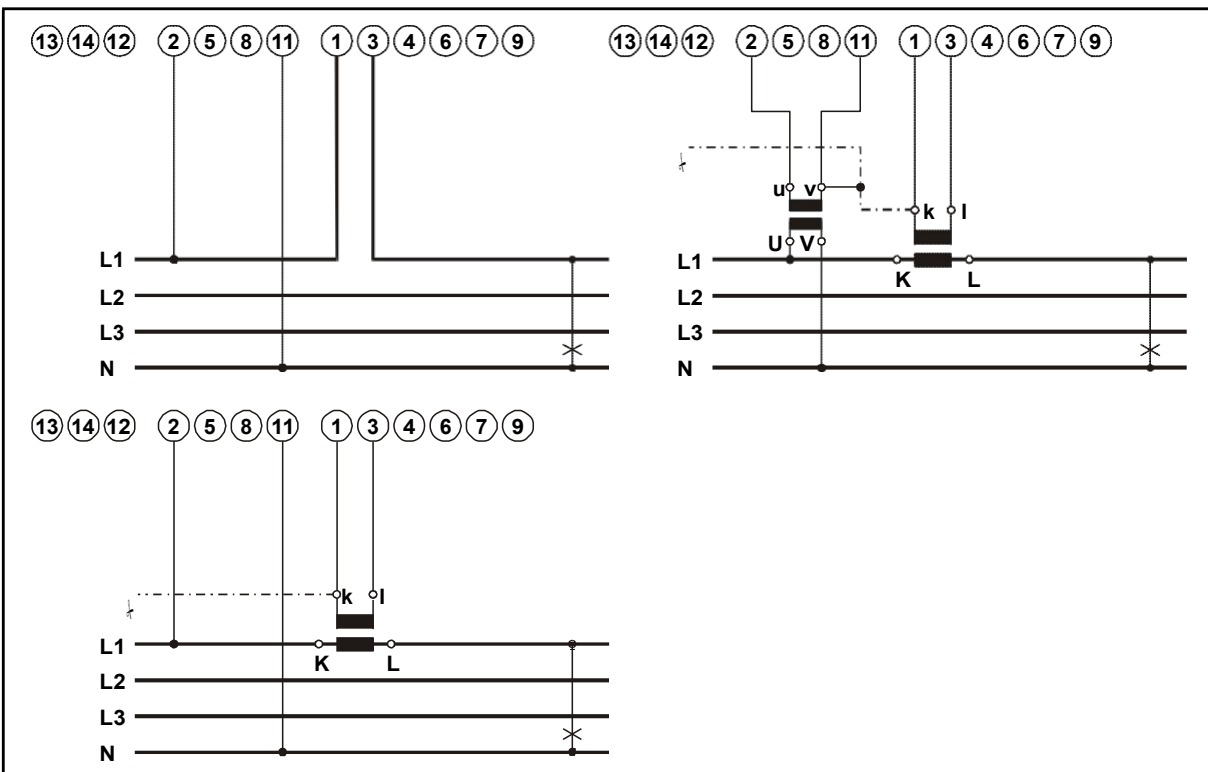

FIGURE 10-4: EXTERNAL WIRING DIAGRAM: 3-PHASE, 4-WIRE BALANCED LOAD (4B)

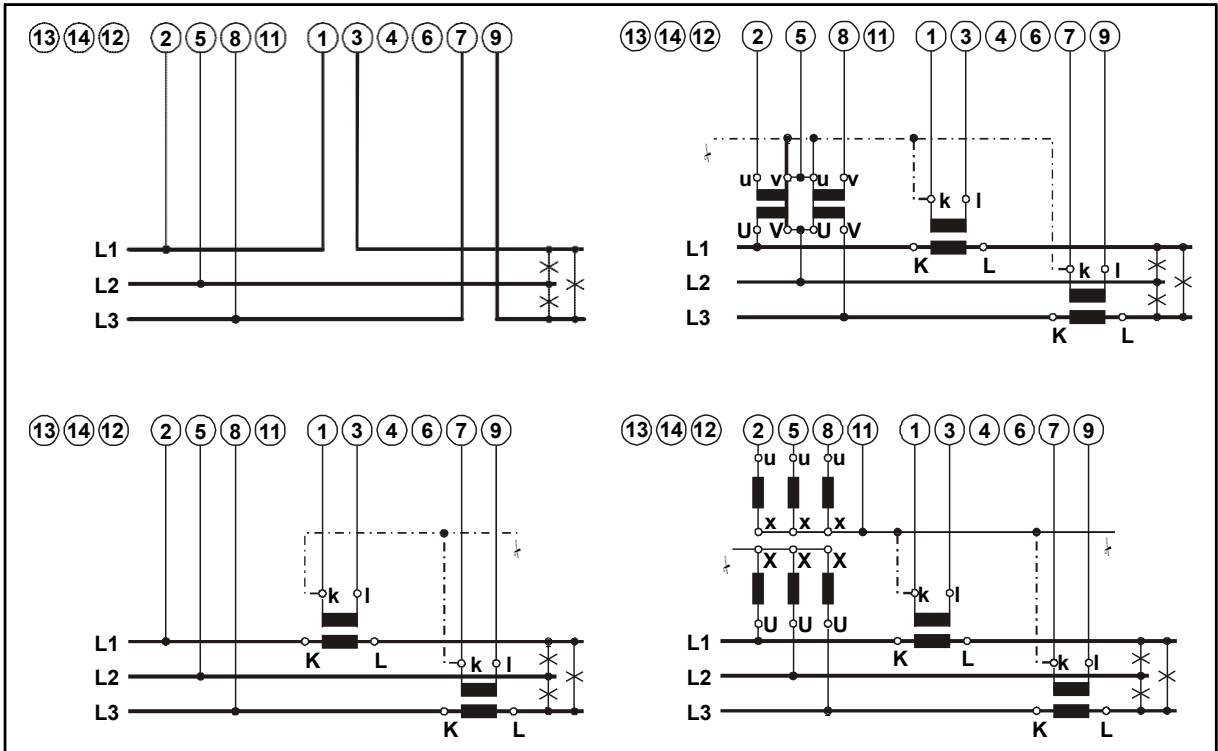

FIGURE 10-5: EXTERNAL WIRING DIAGRAM: 3-PHASE, 3-WIRE UNBALANCED LOAD (3U)

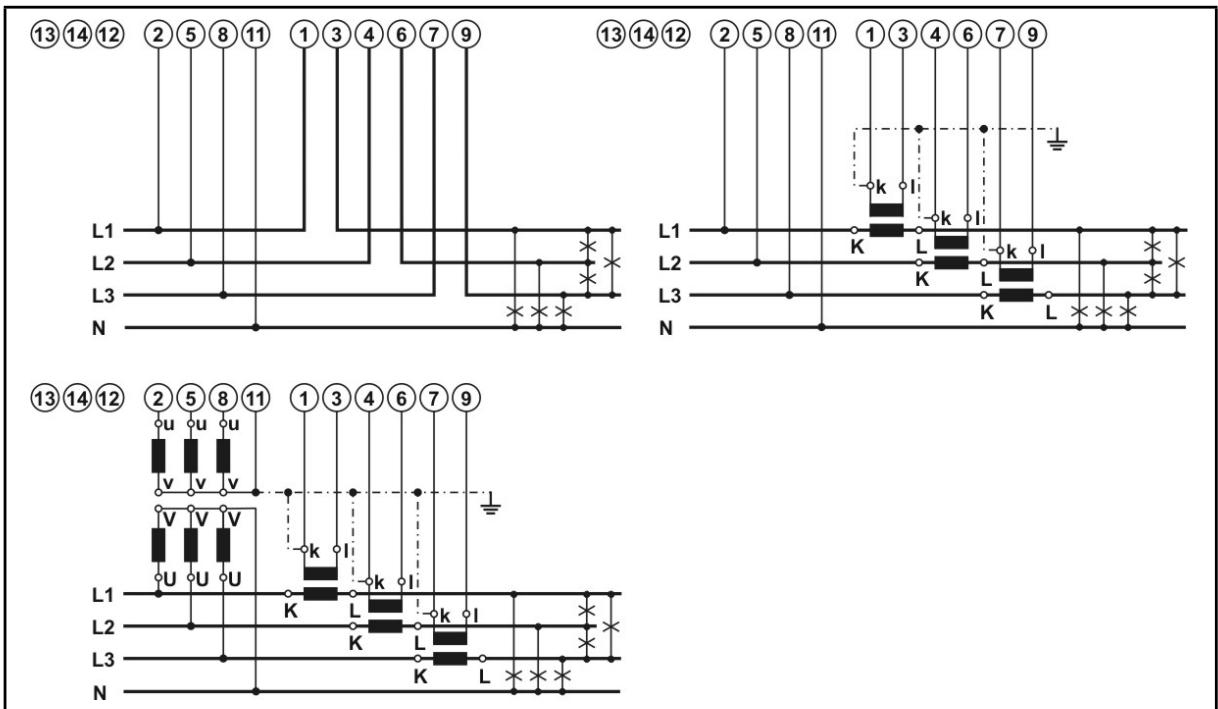

FIGURE 10-6: EXTERNAL WIRING DIAGRAM: 3-PHASE, 4-WIRE UNBALANCED LOAD (4U)

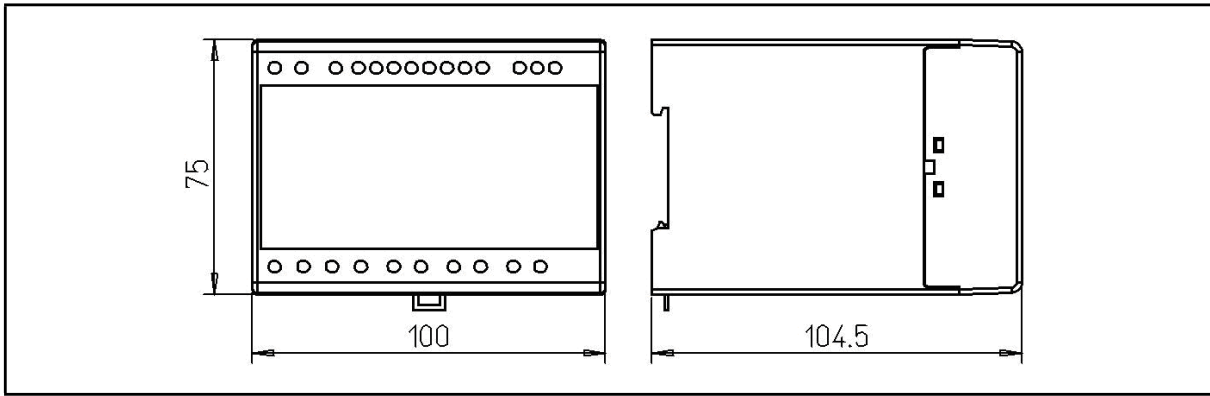

FIGURE 10-8: ENCLOSURE DIMENSIONS

9. RELATED DOCUMENTS

Ref	Document
1	i4MC_V Single Phase Transducer Manual
2	QDSP Technical Manual

10. APPENDIX A: MODBUS COMMUNICATION PROTOCOL

Modbus is enabled via RS232 and RS485 (not USB). The response is the same type as the request.

Two versions of MODBUS register tables are available:

- 1: Compatible with advanced family of transducers (i500)
- 2: Compatible with previous family of transducers (i400) or new on i4MT

Modbus protocol enables operation of device on Modbus networks. For device with serial communication the Modbus protocol enables point to point (for example Device to PC) communication via RS232 communication and multi drop communication via RS485 communication. Modbus protocol is a widely supported open interconnect originally designed by Modicon.

The memory reference for input and holding registers are 30000 and 40000 respectively.

10.1 Actual Measurements

Register table for the actual measurements

Parameter	Type	I500 Compatible Register map		I400 Compatible Register map	
		Start	End	Start	End
Frequency	T5	30105	30106	30049	30050
U1	T5	30107	30108	30057	30058
U2	T5	30109	30110	30059	30060
U3	T5	30111	30112	30061	30062
Uavg (phase to neutral)	T5	30113	30114	30063	30064
φ_{12} (angle between U1 and U2)	T17	30115		30065	
φ_{23} (angle between U2 and U3)	T17	30116		30066	
φ_{31} (angle between U3 and U1)	T17	30117		30067	
U12	T5	30118	30119	30068	30069
U23	T5	30120	30121	30070	30071
U31	T5	30122	30123	30072	30073
Uavg (phase to phase)	T5	30124	30125	30074	30075
I1	T5	30126	30127	30076	30077
I2	T5	30128	30129	30078	30079
I3	T5	30130	30131	30080	30081
INc	T5	30132	30133	30082	30083
Iavg	T5	30136	30137	30086	30087
ΣI	T5	30138	30139	30088	30089
Active Power Total (Pt)	T6	30140	30141	30090	30091
Active Power Phase L1 (P1)	T6	30142	30143	30092	30093
Active Power Phase L2 (P2)	T6	30144	30145	30094	30095
Active Power Phase L3 (P3)	T6	30146	30147	30096	30097
Reactive Power Total (Qt)	T6	30148	30149	30098	30099

Parameter	Type	I500 Compatible Register map		I400 Compatible Register map	
		Start	End	Start	End
Reactive Power Phase L1 (Q1)	T6	30150	30151	30100	30101
Reactive Power Phase L2 (Q2)	T6	30152	30153	30102	30103
Reactive Power Phase L3 (Q3)	T6	30154	30155	30104	30105
Apparent Power Total (St)	T5	30156	30157	30106	30107
Apparent Power Phase L1 (S1)	T5	30158	30159	30108	30109
Apparent Power Phase L2 (S2)	T5	30160	30161	30110	30111
Apparent Power Phase L3 (S3)	T5	30162	30163	30112	30113
Power Factor Total (PFt)	T7	30164	30165	30114	30115
Power Factor Phase 1 (PF1)	T7	30166	30167	30116	30117
Power Factor Phase 2 (PF2)	T7	30168	30169	30118	30119
Power Factor Phase 3 (PF3)	T7	30170	30171	30120	30121
Power Angle Total (atan2(Pt,Qt))	T17	30172		30122	
φ_1 (angle between U1 and I1)	T17	30173		30123	
φ_2 (angle between U2 and I2)	T17	30174		30124	
φ_3 (angle between U3 and I3)	T17	30175		30125	
Internal Temperature	T17	30181		30126	
THD HARMONIC DATA					
U1 THD%	T16	30182		30639	
U2 THD%	T16	30183		30640	
U3 THD%	T16	30184		30641	
U12 THD%	T16	30185		30642	
U23 THD%	T16	30186		30643	
U31 THD%	T16	30187		30644	
I1 THD%	T16	30188		30645	
I2 THD%	T16	30189		30646	
I3 THD%	T16	30190		30647	
I/O STATUS					
Alarm Status Flags (No. 1...16)	T1	30191			
I/O 1 Value	T17	30193			
I/O 2 Value	T17	30194			
I/O 3 Value	T17	30195			
I/O 4 Value	T17	30196			
DEMAND VALUES					
DYNAMIC DEMAND VALUES					
Time Into Period (minutes)	T1	30501		30174	
I1	T5	30502	30503	30175	30176
I2	T5	30504	30505	30177	30178
I3	T5	30506	30507	30179	30180
Apparent Power Total (St)	T5	30508	30509	30181	30182

Parameter	Type	I500 Compatible Register map		I400 Compatible Register map	
		Start	End	Start	End
Active Power Total (Pt) - (positive)	T6	30510	30511	30183	30184
Active Power Total (Pt) - (negative)	T6	30512	30513	30185	30186
Reactive Power Total (Qt) - L	T6	30514	30515	30187	30188
Reactive Power Total (Qt) - C	T6	30516	30517	30189	30190
MAX DEMAND SINCE LAST RESET					
I1	T5	30518	30519	30207	30208
I2	T5	30524	30525	30213	30214
I3	T5	30530	30531	30219	30220
Apparent Power Total (St)	T5	30536	30537	30225	30226
Active Power Total (Pt) - (positive)	T6	30542	30543	30231	30232
Active Power Total (Pt) - (negative)	T6	30548	30549	30237	30238
Reactive Power Total (Qt) - L	T6	30554	30555	30243	30244
Reactive Power Total (Qt) - C	T6	30560	30561	30249	30250

10.2 Register Table for IEEE 754 Measurements

Parameter	Type	I500 Compatible Register map		I4MT Register map	
		Start	End	Start	End
Uavg (phase to neutral)	T_float	32484	32485		
Uavg (phase to phase)	T_float	32486	32487		
ΣI	T_float	32488	32489		
Active Power Total (Pt)	T_float	32490	32491		
Reactive Power Total (Qt)	T_float	32492	32493		
Apparent Power Total (St)	T_float	32494	32495		
Power Factor Total (PFt)	T_float	32496	32497		
Frequency	T_float	32498	32499		
U1	T_float	32500	32501	31530	31531
U2	T_float	32502	32503	31532	31533
U3	T_float	32504	32505	31534	31535
Uavg (phase to neutral)	T_float	32506	32507	31516	31517
U12	T_float	32508	32509	31536	31537
U23	T_float	32510	32511	31538	31539
U31	T_float	32512	32513	31540	31541
Uavg (phase to phase)	T_float	32514	32515	31518	31519
I1	T_float	32516	32517	31524	31525
I2	T_float	32518	32519	31526	31527
I3	T_float	32520	32521	31528	31529
ΣI	T_float	32522	32523	31514	31515

Parameter	Type	I500 Compatible Register map		I4MT Register map	
		Start	End	Start	End
I neutral (calculated)	T_float	32524	32525	31522	31523
I neutral (measured)	T_float	32526	32527		
Iavg	T_float	32528	32529	31520	31521
Active Power Phase L1 (P1)	T_float	32530	32531	31542	31543
Active Power Phase L2 (P2)	T_float	32532	32533	31544	31545
Active Power Phase L3 (P3)	T_float	32534	32535	31546	31547
Active Power Total (Pt)	T_float	32536	32537	31508	31509
Reactive Power Phase L1 (Q1)	T_float	32538	32539	31548	31549
Reactive Power Phase L2 (Q2)	T_float	32540	32541	31550	31551
Reactive Power Phase L3 (Q3)	T_float	32542	32543	31552	31553
Reactive Power Total (Qt)	T_float	32544	32545	31510	31511
Apparent Power Phase L1 (S1)	T_float	32546	32547	31554	31555
Apparent Power Phase L2 (S2)	T_float	32548	32549	31556	31557
Apparent Power Phase L3 (S3)	T_float	32550	32551	31558	31559
Apparent Power Total (St)	T_float	32552	32553	31512	31513
Power Factor Phase 1 (PF1)	T_float	32554	32555		
Power Factor Phase 2 (PF2)	T_float	32556	32557		
Power Factor Phase 3 (PF3)	T_float	32558	32559		
Power Factor Total (PFt)	T_float	32560	32561		
CAP/IND P. F. Phase 1 (PF1)	T_float	32562	32563		
CAP/IND P. F. Phase 2 (PF2)	T_float	32564	32565		
CAP/IND P. F. Phase 3 (PF3)	T_float	32566	32567		
CAP/IND P. F. Total (PFt)	T_float	32568	32569		
φ_1 (angle between U1 and I1)	T_float	32570	32571		
φ_2 (angle between U2 and I2)	T_float	32572	32573		
φ_3 (angle between U3 and I3)	T_float	32574	32575		
Power Angle Total (atan2(Pt,Qt))	T_float	32576	32577		
φ_{12} (angle between U1 and U2)	T_float	32578	32579		
φ_{23} (angle between U2 and U3)	T_float	32580	32581		
φ_{31} (angle between U3 and U1)	T_float	32582	32583		
Frequency	T_float	32584	32585		
U unbalance	T_float	32586	32587		
I1 THD%	T_float	32588	32589		
I2 THD%	T_float	32590	32591		
I3 THD%	T_float	32592	32593		
U1 THD%	T_float	32594	32595		
U2 THD%	T_float	32596	32597		
U3 THD%	T_float	32598	32599		
U12 THD%	T_float	32600	32601		
U23 THD%	T_float	32602	32603		

Parameter	Type	I500 Compatible Register map		I4MT Register map	
		Start	End	Start	End
U31 THD%	T_float	32604	32605		
MAX DEMAND SINCE LAST RESET					
Active Power Total (Pt) - (positive)	T_float	32606	32607	31576	31577
Active Power Total (Pt) - (negative)	T_float	32608	32609	31588	31589
Reactive Power Total (Qt) - L	T_float	32610	32611	31578	31579
Reactive Power Total (Qt) - C	T_float	32612	32613	31590	31591
Apparent Power Total (St)	T_float	32614	32615	31580	31581
I1	T_float	32616	32617	31582	31583
I2	T_float	32618	32619	31584	31585
I3	T_float	32620	32621	31586	31587
DYNAMIC DEMAND VALUES					
Active Power Total (Pt) - (positive)	T_float	32622	32623	31560	31561
Active Power Total (Pt) - (negative)	T_float	32624	32625	31572	31573
Reactive Power Total (Qt) - L	T_float	32626	32627	31562	31563
Reactive Power Total (Qt) - C	T_float	32628	32629	31574	31575
Apparent Power Total (St)	T_float	32630	32631	31564	31565
I1	T_float	32632	32633	31566	31567
I2	T_float	32634	32635	31568	31569
I3	T_float	32636	32637	31570	31571
Internal Temperature	T_float	32658	32659		

10.3 Normalized Actual Measurements

Register table for the normalized actual measurements

Parameter	Type	I500 Compatible Register map		I4MT Register map	
		Register	100% value	Register	100% value
U1	T16	30801	Un	30801	Un
U2	T16	30802	Un	30802	Un
U3	T16	30803	Un	30803	Un
Uavg (phase to neutral)	T16	30804	Un	30804	Un
U12	T16	30805	Un	30805	Un
U23	T16	30806	Un	30806	Un
U31	T16	30807	Un	30807	Un
Uavg (phase to phase)	T16	30808	Un	30808	Un
I1	T16	30809	In	30809	In
I2	T16	30810	In	30810	In
I3	T16	30811	In	30811	In
ΣI	T16	30812	It	30812	It

Parameter	Type	I500 Compatible Register map		I4MT Register map	
		Register	100% value	Register	100% value
I neutral (calculated)	T16	30813	In	30813	In
I neutral (measured)	T16	30814	In	30814	In
Iavg	T16	30815	In	30815	In
Active Power Phase L1 (P1)	T17	30816	Pn	30816	Pn
Active Power Phase L2 (P2)	T17	30817	Pn	30817	Pn
Active Power Phase L3 (P3)	T17	30818	Pn	30818	Pn
Active Power Total (Pt)	T17	30819	Pt	30819	Pt
Reactive Power Phase L1 (Q1)	T17	30820	Pn	30820	Pn
Reactive Power Phase L2 (Q2)	T17	30821	Pn	30821	Pn
Reactive Power Phase L3 (Q3)	T17	30822	Pn	30822	Pn
Reactive Power Total (Qt)	T17	30823	Pt	30823	Pt
Apparent Power Phase L1 (S1)	T16	30824	Pn	30824	Pn
Apparent Power Phase L2 (S2)	T16	30825	Pn	30825	Pn
Apparent Power Phase L3 (S3)	T16	30826	Pn	30826	Pn
Apparent Power Total (St)	T16	30827	Pt	30827	Pt
Power Factor Phase 1 (PF1)	T17	30828	1	30828	1
Power Factor Phase 2 (PF2)	T17	30829	1	30829	1
Power Factor Phase 3 (PF3)	T17	30830	1	30830	1
Power Factor Total (PFt)	T17	30831	1	30831	1
CAP/IND P. F. Phase 1 (PF1)	T17	30832	1		
CAP/IND P. F. Phase 2 (PF2)	T17	30833	1		
CAP/IND P. F. Phase 3 (PF3)	T17	30834	1		
CAP/IND P. F. Total (PFt)	T17	30835	1		
φ_1 (angle between U1 and I1)	T17	30836	100°		
φ_2 (angle between U2 and I2)	T17	30837	100°		
φ_3 (angle between U3 and I3)	T17	30838	100°		
Power Angle Total (atan2(Pt,Qt))	T17	30839	100°		
φ_{12} (angle between U1 and U2)	T17	30840	100°		
φ_{23} (angle between U2 and U3)	T17	30841	100°		
φ_{31} (angle between U3 and U1)	T17	30842	100°		
Frequency	T17	30843	Fn+10Hz		
I1 THD%	T16	30845	100%		
I2 THD%	T16	30846	100%		
I3 THD%	T16	30847	100%		
U1 THD%	T16	30848	100%		
U2 THD%	T16	30849	100%		
U3 THD%	T16	30850	100%		
U12 THD%	T16	30851	100%		
U23 THD%	T16	30852	100%		

Parameter	Type	I500 Compatible Register map		I4MT Register map	
		Register	100% value	Register	100% value
U31 THD%	T16	30853	100%		
MAX DEMAND SINCE LAST RESET					
Active Power Total (Pt) - (positive)	T16	30854	Pt		
Active Power Total (Pt) - (negative)	T16	30855	Pt		
Reactive Power Total (Qt) - L	T16	30856	Pt		
Reactive Power Total (Qt) - C	T16	30857	Pt		
Apparent Power Total (St)	T16	30858	Pt		
I1	T16	30859	In		
I2	T16	30860	In		
I3	T16	30861	In		
DYNAMIC DEMAND VALUES					
Active Power Total (Pt) - (positive)	T16	30862	Pt		
Active Power Total (Pt) - (negative)	T16	30863	Pt		
Reactive Power Total (Qt) - L	T16	30864	Pt		
Reactive Power Total (Qt) - C	T16	30865	Pt		
Apparent Power Total (St)	T16	30866	Pt		
I1	T16	30867	In		
I2	T16	30868	In		
I3	T16	30869	In		
Internal Temperature	T17	30880	100°		

10.4 100% values calculations for normalized measurements

Un =	$(R40147 / R40146) * R30015 * R40149$
In =	$(R40145 / R40144) * R30017 * R40148$
Pn =	Un*In
It =	In Connection Mode: 1b
It =	3*In Connection Modes: 3b, 4b, 3u, 4u
Pt =	Pn Connection Mode: 1b
Pt =	3*Pn Connection Modes: 3b, 4b, 3u, 4u
Fn =	R40150

Register	Content	Type
30015	Calibration voltage	T4
30017	Calibration current	T4

Rxxxxx are Modbus register numbers, see above and section 10.5 for descriptions.

It is suggested that these values are read regularly to ensure any changes made in the settings are incorporated in the calculation.

As the nominal input ranges of the **i4MT** are 500V and 5A, the Used voltage range and Used Current range need to be set correctly to obtain the highest resolution normalized values. These values are set using the QDSP software.

10.5 Register table for the basic settings

Register	Content	Type	Ind	Values / Dependencies	Min	Max	P. Level
40143	Connection Mode	T1	0	No mode	1	5	2
			1	1b - Single Phase			
			2	3b - 3 phase 3 wire balanced			
			3	4b - 3 phase 4 wire balanced			
			4	3u - 3 phase 3 wire unbalanced			
			5	4u - 3 phase 4 wire unbalanced			
40144	CT Secondary	T4		mA			2
40145	CT Primary	T4		A/10			2
40146	VT Secondary	T4		mV			2
40147	VT Primary	T4		V/10			2
40148	Current input range (%)	T16		10000 for 100%	5,00	200,00	2
40149	Voltage input range (%)	T16		10000 for 100%	2,50	100,00	2
40150	Frequency nominal value	T1		Hz	10	1000	2

10.6 Data types decoding

Type	Bit mask	Description
T1		Unsigned Value (16 bit) Example: 12345 = 3039(16)
T2		Signed Value (16 bit) Example: -12345 = CFC7(16)
T3		Signed Long Value (32 bit) Example: 123456789 = 075B CD 15(16)
T4	bits # 15...14 bits # 13...00	Short Unsigned float (16 bit) Decade Exponent(Unsigned 2 bit) Binary Unsigned Value (14 bit) Example: 10000*10 ² = A710(16)
T5	bits # 31...24 bits # 23...00	Unsigned Measurement (32 bit) Decade Exponent(Signed 8 bit) Binary Unsigned Value (24 bit) Example: 123456*10 ⁻³ = FD01 E240(16)
T6	bits # 31...24 bits # 23...00	Signed Measurement (32 bit) Decade Exponent (Signed 8 bit) Binary Signed value (24 bit) Example: - 123456*10 ⁻³ = FDFE 1DC0(16)
T7	bits # 31...24 bits # 23...16 bits # 15...00	Power Factor (32 bit) Sign: Import/Export (00/FF) Sign: Inductive/Capacitive (00/FF) Unsigned Value (16 bit), 4 decimal places Example: 0.9876 CAP = 00FF 2694(16)
T9	bits # 31...24 bits # 23...16 bits # 15...08 bits # 07...00	Time (32 bit) 1/100s 00 - 99 (BCD) Seconds 00 - 59 (BCD) Minutes 00 - 59 (BCD) Hours 00 - 24 (BCD) Example: 15:42:03.75 = 7503 4215(16)
T10	bits # 31...24 bits # 23...16 bits # 15...00	Date (32 bit) Day of month 01 - 31 (BCD) Month of year 01 - 12 (BCD) Year (unsigned integer) 1998..4095 Example: 10, SEP 2000 = 1009 07D0(16)
T16		Unsigned Value (16 bit), 2 decimal places Example: 123.45 = 3039(16)
T17		Signed Value (16 bit), 2 decimal places Example: -123.45 = CFC7(16)
T_Str4		Text: 4 characters (2 characters for 16 bit register)

Type	Bit mask	Description
T_Str6		Text: 6 characters (2 characters for 16 bit register)
T_Str8		Text: 8 characters (2 characters for 16 bit register)
T_Str16		Text: 16 characters (2 characters for 16 bit register)
T_Str40		Text: 40 characters (2 characters for 16 bit register)
T_float	bits # 31 bits # 30..23 bits # 22..0	IEEE 754 Floating-Point Single Precision Value (32 bit) Sign Bit (1 bit) Exponent Field (8 bit) Significand (23 bit) Example: 123.45 stored as 123.45000 = 42F6E666(16)

11. APPENDIX B: CALCULATIONS & EQUATIONS

11.1 Definitions of symbols

No	Symbol	Definition
1	M_v	Sample factor
2	M_p	Average interval
3	U_f	Phase voltage (U_1 , U_2 or U_3)
4	U_{ff}	Phase-to-phase voltage (U_{12} , U_{23} or U_{31})
5	N	Total number of samples in a period
6	n	Sample number ($0 \leq n \leq N$)
7	x, y	Phase number (1, 2 or 3)
8	i_n	Current sample n
9	u_{fn}	Phase voltage sample n
10	u_{ffn}	Phase-to-phase voltage sample n
11	φ_f	Power angle between current and phase voltage f (φ_1 , φ_2 or φ_3)

11.2 Equations

Voltage

$$U_f = \sqrt{\frac{\sum_{n=1}^N u_n^2}{N}}$$

Phase voltage

N – 128 samples in one period (up to 65 Hz)

N – 128 samples in M_v periods (above 65Hz)

Example: 400 Hz $\rightarrow M_v = 7$

$$U_{xy} = \sqrt{\frac{\sum_{n=1}^N (u_{xn} - u_{yn})^2}{N}}$$

Phase-to-phase voltage

u_x, u_y – phase voltages (U_f)

N – a number of samples in a period

Current

$$I_{RMS} = \sqrt{\frac{\sum_{n=1}^N i_n^2}{N}}$$

Phase current

N – 128 samples in a period (up to 65 Hz)

N – 128 samples in more periods (above 65 Hz)

$$I_n = \sqrt{\frac{\sum_{n=1}^N (i_{1n} + i_{2n} + i_{3n})^2}{N}}$$

Neutral current

i – n sample of phase current (1, 2 or 3)
 $N = 128$ samples in a period (up to 65 Hz)

Power

$$P_f = \frac{1}{N} \cdot \sum_{n=1}^N (u_{fn} \cdot i_{fn})$$

Active power by phases

N – a number of periods
 n – a number of samples in a period
 f – phase designation

$$P_t = P_1 + P_2 + P_3$$

Total active power

t – total power
 $1, 2, 3$ – phase designation

$$\text{Sign}Q_f(\varphi)$$

$\varphi \in [0^\circ - 180^\circ] \Rightarrow \text{Sign}Q_f(\varphi) = +1$
 $\varphi \in [180^\circ - 360^\circ] \Rightarrow \text{Sign}Q_f(\varphi) = -1$

Reactive power sign

Q_f – reactive power (by phases)
 φ – power angle

$$S_f = U_f \cdot I_f$$

Apparent power by phases

U_f – phase voltage
 I_f – phase current

$$S_t = S_1 + S_2 + S_3$$

Total apparent power

S_{123} – apparent power by phases

$$Q_f = \text{Sign}Q_f(\varphi) \cdot \sqrt{S_f^2 - P_f^2}$$

Reactive power by phases (Standard)

S_f – apparent power by phases
 P_f – active power by phases

$$Q_f = \frac{1}{N} \cdot \sum_{n=1}^N (u_{fn} \times i_{f[n+N/4]})$$

Reactive power by phases (delayed current method)

N – a number of samples in a period
 n – sample number ($0 \leq n \leq N$)
 f – phase designation

$$Q_t = Q_1 + Q_2 + Q_3$$

Total reactive power

Q_f – reactive power by phases

$$\varphi_s = \arctan 2(P_t, Q_t)$$

$$\varphi_s = [-180^\circ, 179,99^\circ]$$

Total power angle

P_t – total active power
 S_t – total apparent power

$$PF_t = \frac{P_t}{S_t}$$

3 phase power factor

P_t – total active power

S_t – total apparent power

$$PF_f = \frac{P_f}{S_f}$$

Power factor by phases

P_f – phase active power

S_f – phase apparent power

THD

$$I_f \text{THD}(\%) = \frac{\sqrt{\sum_{n=2}^{63} I_n^2}}{I_1} \cdot 100$$

Current THD

I_1 – value of first harmonic

n – number of harmonic

$$U_f \text{THD}(\%) = \frac{\sqrt{\sum_{n=2}^{63} U_f n^2}}{U_{f1}} \cdot 100$$

Phase voltage THD

U_1 – value of first harmonic

n – number of harmonic

$$U_{ff} \text{THD}(\%) = \frac{\sqrt{\sum_{n=2}^{63} U_{ff} n^2}}{U_{ff1}} \cdot 100$$

Phase-to-phase voltage THD

U_1 – value of first harmonic

n – number of harmonic



GE VERNOVA

GE Vernova
St Leonards Building
Redhill Business Park
Stafford, ST16 1WT, UK
+44 (0) 1785 250 070
www.governova.com/grid-solutions/contact.htm

© 2025 GE Vernova. All rights reserved. Information contained in this document is indicative only. No representation or warranty is given or should be relied on that it is complete or correct or will apply to any particular project. This will depend on the technical and commercial circumstances. It is provided without liability and is subject to change without notice. Reproduction, use or disclosure to third parties, without express written authority, is strictly prohibited.

i4MT/EN/M/C