

GE Vernova
Grid Solutions

iSTAT I500

Enhanced 1ph Transducer

Manual

Publication reference: I500SP/EN/M/D

1. SAFETY SECTION





This Safety Section should be read before commencing any work on the equipment.

1.1 Health and Safety

The information in the Safety Section of the product documentation is intended to ensure that products are properly installed and handled in order to maintain them in a safe condition. It is assumed that everyone who will be associated with the equipment will be familiar with the contents of the Safety Section.

1.2 Explanation of symbols and labels

The meaning of symbols and labels may be used on the equipment or in the product documentation, is given below.

	
Caution: refer to product documentation	Caution: risk of electric shock
	
Protective/safety *earth terminal	Functional *earth terminal Note: This symbol may also be used for a protective/safety earth terminal if that terminal is part of a terminal block or sub-assembly e.g. power supply.

*NOTE: The term earth used throughout the product documentation is the direct equivalent of the North American term ground.

2. INSTALLING, COMMISSIONING AND SERVICING



Equipment connections

Personnel undertaking installation, commissioning or servicing work on this equipment should be aware of the correct working procedures to ensure safety. The product documentation should be consulted before installing, commissioning or servicing the equipment.

Terminals exposed during installation, commissioning and maintenance may present a hazardous voltage unless the equipment is electrically isolated.

If there is unlocked access to the rear of the equipment, care should be taken by all personnel to avoid electrical shock or energy hazards.

Voltage and current connections should be made using insulated crimp terminations to ensure that terminal block insulation requirements are maintained for safety. To ensure that wires are correctly terminated the correct crimp terminal and tool for the wire size should be used.

Before energising the equipment it must be earthed using the protective earth terminal, or the appropriate termination of the supply plug in the case of plug connected equipment. Omitting or disconnecting the equipment earth may cause a safety hazard.

The recommended minimum earth wire size is 2.5mm², unless otherwise stated in the technical data section of the product documentation.

Before energising the equipment, the following should be checked:

- Voltage rating, frequency and polarity
- VT ratio and phase sequence
- CT circuit rating and integrity of connections;
- Protective fuse rating;
- Integrity of earth connection (where applicable)
- Supply voltage

3. EQUIPMENT OPERATING CONDITIONS

The equipment should be operated within the specified electrical and environmental limits.

3.1 Current transformer circuits



Do not open the secondary circuit of a live CT since the high level voltage produced may be lethal to personnel and could damage insulation.

3.2 Battery Replacement



Where internal batteries are fitted they should be replaced with the recommended type and be installed with the correct polarity, to avoid possible damage to the equipment.

3.3 Insulation and dielectric strength testing



Insulation testing may leave capacitors charged up to a hazardous voltage. At the end of each part of the test, the voltage should be gradually reduced to zero, to discharge capacitors, before the test leads are disconnected.

3.4 Opening enclosure



There are no customer replaceable PCB cards or components within the enclosure, so the enclosure should not be opened.

4. DECOMMISSIONING AND DISPOSAL



Decommissioning: The auxiliary supply circuit in the relay may include capacitors across the supply or to earth. To avoid electric shock or energy hazards, after completely isolating the supplies to the relay (both poles of any dc supply), the capacitors should be safely discharged via the external terminals prior to decommissioning.

Disposal: It is recommended that incineration and disposal to water courses is avoided. The product should be disposed of in a safe manner. Any products containing batteries should have them removed before disposal, taking precautions to avoid short circuits. Particular regulations within the country of operation, may apply to the disposal of lithium batteries.

5. TECHNICAL SPECIFICATIONS

5.1 Protective fuse rating

The recommended maximum rating of the external protective fuse for this equipment is 6A, Red Spot type or equivalent, unless otherwise stated in the technical data section of the product documentation.

Insulation class:	IEC 61010-1 : 2002 Class I EN 61010-1 : 2002 Class I	This equipment requires a protective (safety) earth connection to ensure user safety.
Insulation Category (Over voltage):	IEC 61010-1 : 2002 600V Category III EN 61010-1 : 2002 600V Category III	
Environment:	IEC 61010-1 : 2002 Pollution degree 2 EN 61010-1 : 2002 Pollution degree 2	Compliance is demonstrated by reference to generic safety standards.
Product Safety: 	2006/95/EC EN 61010-1 : 2002	Compliance with the European Commission Low Voltage Directive. Compliance is demonstrated by reference to generic safety standards.

CONTENT

1.	SAFETY SECTION	1
1.1	Health and Safety	1
1.2	Explanation of symbols and labels	1
2.	INSTALLING, COMMISSIONING AND SERVICING	2
3.	EQUIPMENT OPERATING CONDITIONS	3
3.1	Current transformer circuits	3
3.2	Battery Replacement	3
3.3	Insulation and dielectric strength testing	3
3.4	Opening enclosure	3
4.	DECOMMISSIONING AND DISPOSAL	3
5.	TECHNICAL SPECIFICATIONS	4
5.1	Protective fuse rating	4
6.	INTRODUCTION	9
6.1	General	9
6.2	KEY MESSAGES	9
6.3	iSTAT I500 Family	10
6.3.1	I5MV class 0.2 communicating Voltage transducer	10
6.3.2	I5MC class 0.2 communicating Current transducer	10
6.3.3	i5MS class 0.2 communicating Multifunction Transducer.	10
6.3.4	i5ML class 0.2 communicating Network Recorder	10
6.3.5	Software:	10
6.4	Measurements	11
6.5	Hardware features	11
6.6	Communications	11
6.7	Inputs and Outputs	12
6.8	Applications	12
7.	HARDWARE	13
7.1	Communications	13
7.1.1	RS232 /RS485 communications	13
7.1.2	Ethernet and USB communications	14
7.1.3	Communication connection details	15
7.2	Inputs and Outputs	15

7.2.1	Energy Contacts (Pulse outputs)	16
7.2.2	Alarm (outputs)	16
7.2.3	Analogue (outputs)	16
7.2.4	Digital Input	17
7.2.5	Watchdog Output	17
7.3	Auxiliary Supply	17
7.4	Measurement Inputs	18
<hr/>		
8.	SETTINGS	19
8.1	Introduction	19
8.2	QDSP Software	19
8.2.1	Devices Management	19
8.2.2	Instrument settings	19
8.2.3	Real time measurements	19
8.2.4	Data Analysis	19
8.2.5	Software upgrading	19
8.3	Setting Procedure	19
8.4	General Settings	20
8.4.1	Description and Location	20
8.4.2	Average Interval	20
8.4.3	Date and Time	20
8.4.4	Maximum Demand calculation (MD mode)	20
8.4.5	Starting Current for PF and PA (mA)	20
8.4.6	Starting current for all powers (mA)	21
8.4.7	Starting voltage for SYNC (V)	21
8.5	Connection	21
8.5.1	Setting of current and voltage ratios	22
8.5.2	Used Voltage and Current Range	22
8.5.3	Nominal Frequency	22
8.6	Communication	22
8.6.1	Serial Communication parameters	22
8.6.2	Ethernet Communication	22
8.6.3	USB	23
8.7	Security	23
8.7.1	Password setting	23
8.7.2	Password modification	23
8.8	Energy	23
8.8.1	Common Energy Exponent	23
8.8.2	Measured Energy	24
8.8.3	Counter Divider	24
8.9	Inputs and Outputs	25

8.9.1	Analogue output module	25
8.9.2	Alarm/Digital Output Module	26
8.9.3	Pulse Output Module	26
8.9.4	Digital Input module	26
8.9.5	Watchdog Output module	26
8.10	Alarms	27
8.10.1	Alarm setting	27
8.10.2	Types of Alarm	27
8.11	Memory	28
8.11.1	Memory division	28
8.11.2	Memory Operation	28
8.11.3	Memory clearing	28
8.12	Data Recorders	28
8.13	Reset Operations	29
8.13.1	Reset energy counters	29
8.13.2	Reset maximal MD values	29
8.13.3	Reset the last MD period	29
9.	SYSTEM MODES	30
9.1	Connection mode	30
9.2	Power mode	30
9.3	Operating energy quadrants	30
10.	INSTRUMENTATION	31
10.1	Measurements	31
10.2	Glossary	31
10.3	Supported Measurements	32
10.3.1	Voltage	33
10.3.2	Current	33
10.3.3	Frequency	33
10.3.4	Harmonics	33
10.4	Power, power factor and energy	34
10.4.1	Power	34
10.4.2	Power factor	35
10.4.3	Energy	35
10.4.4	Maximum demands (MDs)	35
11.	COMMUNICATIONS	37
11.1	Communications ports	37
11.2	QDSP Setting and Monitoring Software	37
11.3	MODBUS	37

12.	BATTERY REPLACEMENT	38
13.	TECHNICAL DATA	39
14.	WIRING DIAGRAMS	44
15.	RELATED DOCUMENTS	46

6. INTRODUCTION

6.1 General

The **I500** is a multifunction transducer family aimed at the high and medium voltage and industrial market segments throughout the world. It allows the user to select the most appropriate model from the family and customise the features to suit the particular application.

The **I500** multifunction transducer family integrates a number of measurements, monitoring, recording and metering functions in the same unit for comprehensive power system management. The **I500** offers:

- High accuracy measurements
- A cost-effective solution for High, Medium Voltage and Industrial markets
- Power Quality analysis to EN50160
- Modbus protocol for integrating into energy management and control systems.
- Tariff and cost management functions for use in sub metering applications.
- Digital inputs and outputs and analogue outputs
- CE certification

6.2 KEY MESSAGES

- The iSTAT **I500** provides **Class 0.2** measurement of Volts, Current and Power and **Class 0.5S** for Energy measurement.
- The iSTAT **I500** is an **economical** choice for measurements, with a family that allows the user to tailor the transducer and functions to the application.
- The **comprehensive** Energy Cost Management Library of functions enables the **I500** to store energy readings in 4 registers and programme tariff structures and costs. This data can be recorded, communicated or read via pulse outputs
- **I500** offers multiple communication hardware options to allow integration in to a wide range of applications.
- **I500** allows communication to MODBUS based systems that are widely used by industrial and utility customers worldwide.
- **I500** is available with either Ring or Pin terminals to suit the installation requirements.

iSTAT – **THE standard** measurement platform

- Multiple advanced configuration features fitted as standard.
- Comprehensive choice of features for measurement applications – to satisfy all metering, measurement and data recording and power quality applications
- Flexible programmable software (**QDSP**) allows off line and on line settings and data interpretation
- Complete and informative documentation, **QDSP** also includes help information.
- A choice of different input and output options.

Simple to fit, **simple** to set, **simple** to connect

6.3 iSTAT I500 Family

The **I500** family consists of 3-phase multifunction transducers and single phase transducers all of which are 0.2% accurate. **This manual details the single phase transducer models.**

6.3.1 **I5MV** class 0.2 communicating **Voltage** transducer

The transducer is used for monitoring and measuring the **Voltage and Frequency** of single phase electrical power distribution systems. The meter is provided with 16 program adjustable alarms, 1 or 2 input or output modules and communication. With the RS232/RS485, Ethernet or USB communication, the meter can be set and measurements can be checked.

6.3.2 **I5MC** class 0.2 communicating **Current** transducer

The transducer is used for monitoring and measuring the **Current and Frequency** of single phase electrical power distribution systems. The meter is provided with 16 program adjustable alarms, 1 or 2 input or output modules and communication. With the RS232/RS485, Ethernet or USB communication, the meter can be set and measurements can be checked.

6.3.3 **i5MS** class 0.2 communicating **Multifunction** Transducer.

The transducer is used for monitoring and measuring electric quantities of single phase electrical power distribution systems. From the measured values quantities are calculated i.e. voltage, current, frequency, energy, power, power factor, THD phase angles, etc.

The meter is provided with 16 program adjustable alarms, 1 or 2 input or output modules and communication. With the RS232/RS485, Ethernet or USB communication, the meter can be set and measurements can be checked.

6.3.4 **i5ML** class 0.2 communicating **Network Recorder**

The transducer is used for monitoring, measuring and recording measurements of electric quantities of single phase electrical power distribution systems. The **i5ML** measures all the same parameters as the **i5MS** and up to 16 measurements and up to 16 alarms can be recorded in the internal 8MB memory. The memory is separated into two sections for measurements (A and B) and one section for recording alarms. The memory division is defined by the user.

6.3.5 Software:

The QDSP software is used for configuring the devices as on all iSTAT communicating products.

The QDSP software is used for configuration and for browsing values from the devices. In addition the QDSP software is used for downloading and analysing recorded data.

QDSP also offers additional features such as upgrading from a secure web site for both the QDSP software and the transducer firmware.

6.4 Measurements

The **I500** single phase family is ideally suited to applications where continuous monitoring of a single phase system is required:

- **i5MV**: local and remote indication of Voltage and Frequency
- **i5MC**: local and remote indication of Current and Frequency
- **i5MS**: local and remote indication for ac switchboard power measurements, energy metering into a remote energy management system
- **i5ML**: System monitoring and alarm recording, local and remote indication for ac switchboard power measurements, energy metering into a remote energy management system,

6.5 Hardware features

The **i5MC/MV/MS/ML** has a number of hardware features that are designed to make the installation, commissioning and use of the transducers as simple as possible, see TABLE 7-1.

The **I500** has 2 LED indicators, Red for power on and Green for communications activity.

The **I500** has 2 ranges of universal auxiliary supply available and an auto ranging current and voltage measurement input so that it can be used in most site conditions without the need to specify this information at the order stage.

The **i5ML** has 8MB of internal memory to support the data logging functions.

TABLE 7-1 : HARDWARE	i5MV	i5MC	i5MS	i5ML
Auto range V&I input	●	●	●	●
Watchdog (optional)	●	●	●	●
Universal Power supply	HI or LO	HI or LO	HI or LO	HI or LO
4 Energy counters			●	●
Real time clock (battery)				●
Internal Flash Memory				8MB

6.6 Communications

The **I500** family has a wide range of communications options that allow it to integrate with a number of different management systems, see TABLE 7-2.

TABLE 7-2 : COMMUNICATIONS		
COM	Port	Connector
1	RS232/RS485	Both options on one DB9 connector, in addition the RS485 connections are available via terminals
1	Ethernet	RJ-45 connector
1	USB	USB-B connector
2	RS485	Terminals

The **i5MC/MV/MS/ML** have a communications port with the option of an RS232/RS485 wired port, a USB port or a combined Ethernet and USB port that will support MODBUS (RTU or TCP).

6.7 Inputs and Outputs

The **i5MC/MV/MS/ML** has two I/O module positions, each of which can support an I/O module as shown in TABLE 7-3. Each module configuration is specified at the order stage.

TABLE 7-3 : I/O OPTIONS	Quantity	Position	Specification
Alarm output	2 outputs	any I/O	48 V AC/ VDC (+40% max), 1000mA max
Analogue output	2 outputs	any I/O	Fully programmable +/- 20mA, +/- 10V
Watchdog output	2 outputs	any I/O	48 V AC/ VDC (+40% max), 1000mA max
Pulse output (i5MS, i5ML)	2 outputs	any I/O	40 VAC/DC 30mA max 2....1000ms
Digital input	2 inputs	any I/O	48 V AC/DC (+40% max)

6.8 Applications

The **i5MC/MV/MS/ML** can be used in a wide range of different applications depending on the model, the applications are summarised in Table 7-4.

TABLE 7-4 : APPLICATION	i5MV	i5MC	i5MS	i5ML
Voltage / Current Meas.	●	●	●	●
Power measurements			●	●
Energy Metering			●	●
Programmable alarms	●	●	●	●
Measurement recorder				●

7. HARDWARE

7.1 Communications

The **I500** can be supplied with various communications options: RS232/RS485, Ethernet, USB or Ethernet and USB, which must be specified when ordering. The communication protocols that are available are Modbus RTU and Modbus TCP, which are detailed in a separate manual. The communications enables the remote viewing of measurements and viewing and setting of system parameters.



FIGURE 8-1: I500 SINGLE PHASE

The **I500** has a communications port (COM1) mounted under a transparent cover on the front.

7.1.1 RS232 /RS485 communications

The **I500** transducers can be supplied with a combined RS232/RS485 port (COM1) via a front mounted DB9 9 pin. The RS485 communications are also available via terminals for field wiring. The RS232/RS485 port can be used for either RS232 or RS485, but not both since the port cannot support both options at the same time. All RS232 wiring must be removed before the RS485 communications on COM1 will operate correctly

WARNING: DO NOT ATTEMPT TO CONNECT USING RS232 AND RS485 COMMUNICATIONS AT THE SAME TIME AS DAMAGE CAN OCCUR. LEAVE THE UNUSED PINS UNCONNECTED.

Connection information for COM1 will be shown on a label as depicted in table 8-1.

The connection of RS232 communications is usually between the **I500** and a PC, the maximum connection length is 15 metres.

RS485 communications enables simultaneous connection to a maximum of 32 communicating devices; two-wire RS485 only is used. For RS485 communications, the PC will require either an internal RS485 communications port or an external RS232/RS485 or USB/RS485 interface. In both cases the device must provide automatic RS485 data flow control. The maximum connection length is 1000 metres. Conductors A and B should be terminated with a 120Ω terminating resistor on the units at each end of the RS485 network.

Connection Label				
COMMUNICATION				
DB9 - FEMALE				
RS232			RS485	
Tx	Rx	⊥	B	A
2	3	5	7	8

TABLE 8-1A: RS232.RS485 DSUB CONNECTIONS

Connection Label	
COM	
RS485	A ○ 23
	NC ○ 24
	B ○ 25

TABLE 8-2B: RS485 TERMINAL CONNECTIONS

7.1.2 Ethernet and USB communications

The **I500** transducers can be supplied with a USB port, or a combined USB and Ethernet port via front mounted RJ45 and USB type B connectors. If both Ethernet and USB are fitted they can be used simultaneously allowing interrogation locally and remotely at the same time.

Ethernet communication allows for integration of the device into global Ethernet-based networks. The device supports fast Ethernet (10/100 Mbps). For proper operation, standard IEEE 802.3 compliant 100BASE-T CAT5 Ethernet cable is recommended. The device is supplied with a unique MAC address for identification, which is printed on the label.

USB communication serves as a fast peer-to-terminal data link. The instrument is detected by the host as a USB 2.0 compatible device.

Connection information will be shown on a label as depicted in table 8-3.

Connection Label
COMMUNICATION
Ethernet
MAC No.:
USB 2.0 Type B

TABLE 8-3: ETHERNET.USB CONNECTIONS

COM1 RS485 via Terminals 23-25 is not available when Ethernet and/or USB have been selected.

7.1.3 Communication connection details

	Connector	Terminals		Data direction	Description
RS232	DB9		1	Not connected	-
			2	From	Data transmission (Tx)
			3	To	Data reception (Rx)
			4	Not connected	-
			5	-	Ground
			6	Not connected	-
			7	-	Do not connect!
			8	-	Do not connect!
			9	Not connected	-
RS485	DB9		1	Not connected	-
			2	-	Do not connect!
			3	-	Do not connect!
			4	Not connected	-
			5	-	Do not connect!
			6	Not connected	-
			7	To/From	B
			8	To/From	A
			9	Not connected	-
	SCREW-IN		23	To/From	A
			24	Not connected	C
			25	To/From	B
Ethernet	RJ-45		100BASE-T CAT5 cable recommended		
USB	USB-B		Standard USB 2.0 compatible cable recommended (Type B plug)		

TABLE 8-3: PRIMARY COMMUNICATIONS

7.2 Inputs and Outputs

The **i5MC/MV/MS/ML** can be supplied with 1 or 2 hardware I/O modules which are fitted internally during manufacture and need to be specified when ordering. These modules can be factory configured to one of the options shown in TABLE 8-4.

TABLE 8-4: I/O OPTIONS	Quantity	Position
Alarm output	2 outputs	any I/O
Analogue output	2 outputs	any I/O
Watchdog output	2 outputs	any I/O
Pulse output (i5MS, i5ML)	2 outputs	any I/O
Digital input	2 inputs	any I/O

Since each hardware module is independent and isolated from any other, the **i500** can be supplied with any combination of modules.

The terminal connections are 15, 16 for I/O module 1, and 17, 18 for I/O module 2.

7.2.1 Energy Contacts (Pulse outputs)

The energy pulsed outputs that can be used for the external monitoring of energy consumption that is measured by the **i5MS/ML**. The pulsed outputs' energy measurement can be adapted to the customer's needs via the communications link.

I/O 1	
Pulse output	
40 V DC/AC	+~ 15
30 mA	-~ 16

Pulse output (solid state) module for energy counters. (Example of pulse module as I/O module 1)

TABLE 8-5: ENERGY PULSE OUTPUTS

When all hardware modules are used for energy contacts, the **i5MS/ML** will provide a maximum of 2 independent pulse outputs.

7.2.2 Alarm (outputs)

The alarm contacts can be used for external monitoring of any alarm condition. The alarms can be set via the communications link.

Any measurement available from the **i5MC/MV/MS/ML** can be mapped to an alarm group or directly to a contact.

The alarm module has two terminals (see TABLE 8-6).

I/O 1	
Relay output	
48 V DC/AC	+~ 15
1000 mA	-~ 16

Alarm (relay) module. (Example of alarm module as I/O module 1)

TABLE 8-6: ALARM CONTACTS

7.2.3 Analogue (outputs)

The **i5MC/MV/MS/ML** can be supplied with 1 or 2 independent analogue outputs, each of which can be set within the range $\pm 20\text{mA}$ or $\pm 10\text{V}$. The analogue output can be configured to represent any of the instantaneous measured values. The outputs can be set via the communications link.

The analogue module has two terminals (see TABLE 8-7).

I/O 1	
Analogue output	
0...-/±20 mA	+ δ 15
0...-/±10 V	- ϵ 16

Analogue output module with analogue output, proportional to measured quantities. The outputs may be either short or open-circuited. They are electrically insulated from each other and from all other circuits. (Example of analogue output module as I/O module 1)

TABLE 8-7: ANALOGUE OUTPUTS

7.2.4 Digital Input

The **i5MC/MV/MS/ML** can be supplied with 1 or 2 independent digital inputs

I/O 1	
Digital input	
48 V DC/AC	+/~ 15
+ 40% max	-/~ 16

Digital input module enables reception of impulse signal. (Example of digital module as I/O module 1)

TABLE 8-8: DIGITAL INPUTS

7.2.5 Watchdog Output

The **i5MC/MV/MS/ML** can be supplied with 1 or 2 independent Watchdog outputs

The alarm module has two terminals (see TABLE 8-9).

I/O 1	
Watchdog output	
48 V DC/AC	+/~ 15
1000 mA	-/~ 16

Watchdog (relay) module. (Example of Watchdog module as I/O module 1)

TABLE 8-9: WATCHDOG OUTPUTS

7.3 Auxiliary Supply

The **I500** Measuring transducer has a universal (AC/DC) auxiliary power supply. It is supplied in two versions, either LOW (20 VDC – 70 VDC; 48 VAC – 77 VAC) or HIGH (70 VDC – 300 VDC; 80 VAC – 276 VAC), which must be defined at time the order.

Connection details and ratings are shown on a label as detailed in TABLE 8-10.

AUX	
19...70 V DC	⊕ 12
48...77 V AC	+/~L 13
40...65 Hz	-/~N 14
< 5 VA	
Connection of universal power supply (LOW) to terminals 13, 14 and 12	
AUX	
70...300 V DC	⊕ 12
80...276 V AC	+/~L 13
40...65 Hz	-/~N 14
< 5 VA	
Connection of universal power supply (HIGH) to terminals 13, 14 and 12	

TABLE 8-10: AUXILAIRY SUPPLY

NOTE: FOR SAFETY PURPOSES IT IS IMPORTANT THAT ALL THREE WIRES ARE FIRMLY CONNECTED. THEY SHOULD BE CONNECTED ONLY TO THE DESIGNATED TERMINALS AS SHOWN ON THE LABEL ABOVE AS WELL AS ON THE FRONT LABEL OF THE TRANSDUCER.

AN EARTH CONNECTION IS ALWAYS REQUIRED FOR SAFETY AS THERE ARE ACCESSIBLE METAL COMPONENTS.

7.4 Measurement Inputs

The **I500** has an auto-ranging voltage and current input with nominal values of 230V and 5A.

This information is shown on the label as detailed in TABLE 8-11, the wiring connections are shown in section 15.

INPUTS
Current:
Voltage:
Frequency:
Connection:

TABLE 8-11: MEASUREMENT INPUTS

8. SETTINGS

8.1 Introduction

Instrument settings can be remotely modified with the QDSP software, when connected to a PC.

8.2 QDSP Software

QDSP is a software tool for complete monitoring of measuring instruments, connected to a PC via serial, USB or TCP/IP communication. A user-friendly interface consists of five segments: devices management, instrument settings, real-time measurements, data analysis and software upgrading.

A separate QDSP manual is available that defines the operation of QDSP in detail.

8.2.1 Devices Management

The communications parameters for any connected device can be modified. Also included are browsers which scan the communications networks attached to the PC and identify all of the devices connected with their addresses and communications parameters. This can be done on RS232, RS485, USB and Ethernet connections.

8.2.2 Instrument settings

The instrument settings are organized in a tree structure and they can be modified simply as required. In addition to transferring settings to the instrument, QDSP can also store the data to settings files and read it back when required.

8.2.3 Real time measurements

All measurements can be displayed in real time in a table. Harmonics and their time-reconstruct signals are displayed graphically.

If further processing of the measurement data is required it can be copied via a clipboard and inserted into standard Windows formats.

8.2.4 Data Analysis

Analysis can be performed on the recorded data in the i5MR and i5MQ. Recorded values can be displayed in a tabular or graphical form. The events that triggered alarms can be analysed or a report on supply voltage quality can be made. All data can be exported to an Access database, Excel worksheet or a text file.

8.2.5 Software upgrading

It is suggested that the latest version of QDSP should always be used and if the computer is connected to the internet QDSP can be setup to check if an upgrade is available for download.

8.3 Setting Procedure

In order to modify the settings with QDSP the current parameters must be loaded first. Instrument settings can be acquired via a communications link or they can be loaded off-line from a file on a local disk. The QDSP contains sample settings files for each product variant that can be downloaded to show the range of settings available for the specific product. These files can be modified and then stored under a different name allowing an instrument configuration to be generated off-line without an instrument attached, and downloaded at a later date.

Settings are displayed in the QDSP setting window, the left part displays a hierarchical tree structure of settings, the right hand part displays parameter values of the chosen setting group, see Figure 9-1.

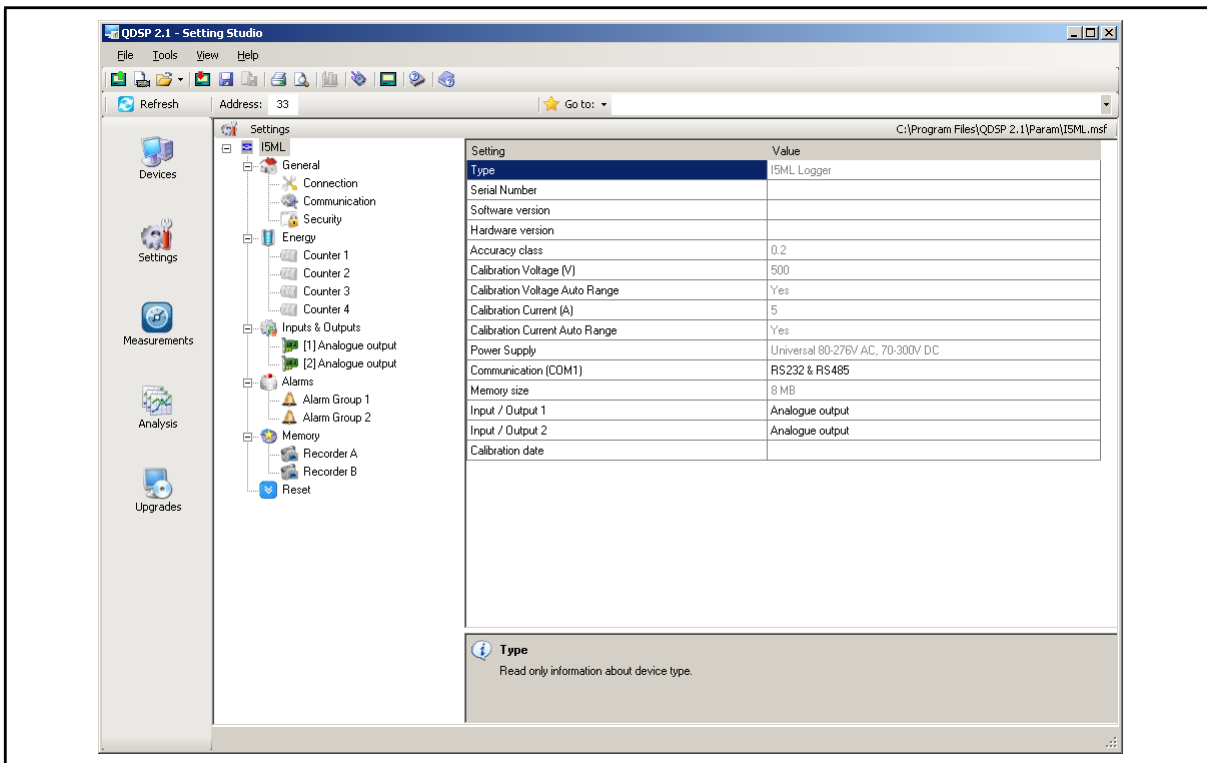

FIGURE 9-1 : QDSP INTERFACE

8.4 General Settings

General Settings are essential for the operation of the measuring transducer. They are divided into three additional sublevels (Connection, Communication and Security).

8.4.1 Description and Location

These are two parameters that are extended for easier recognition of a particular instrument. They allow for the identification or location to be defined where measurements are performed.

8.4.2 Average Interval

The averaging interval defines the refresh rate of measurements for communications.

8.4.3 Date and Time

Set the date and time of the meter, Setting is important for correct data storage operation, maximum values (MD), etc.

8.4.4 Maximum Demand calculation (MD mode)

The **i5MC/MV/MS/ML** provides maximum demand values from a thermal function demand values.

See section 11 for details.

8.4.5 Starting Current for PF and PA (mA)

At all measuring inputs noise is usually present. It usually has consistent amplitude and its influence on the accuracy of the measurement increases as the amplitude of the signal to be measured decreases. It is also present when measuring signals are not connected and can give false readings for all subsequent calculations.

By setting a starting current for Total Power Factor and Power Angle, a minimum level is defined where the measurements and calculations commence, reducing the effect of any input noise.

8.4.6 Starting current for all powers (mA)

By setting a Minimum Starting Current, a level is defined where the measurements of Current and calculation of all powers commence, reducing the effect of any input noise.

8.4.7 Starting voltage for SYNC (V)

This parameter sets a voltage threshold for measurement synchronization.

If the voltage signal is below this threshold or there is no voltage signal, current synchronization is used. If current is also below the starting current value, the fixed (default) frequency value is used for synchronization. This Frequency value is set under 'Connection'.

8.5 Connection

The setting of the connection parameters must reflect the actual applications or the measurements will not be valid.

All of the settings in this section should be defined before the settings for the analogue and alarm outputs, as changes to this section may automatically change the measurements and output settings.

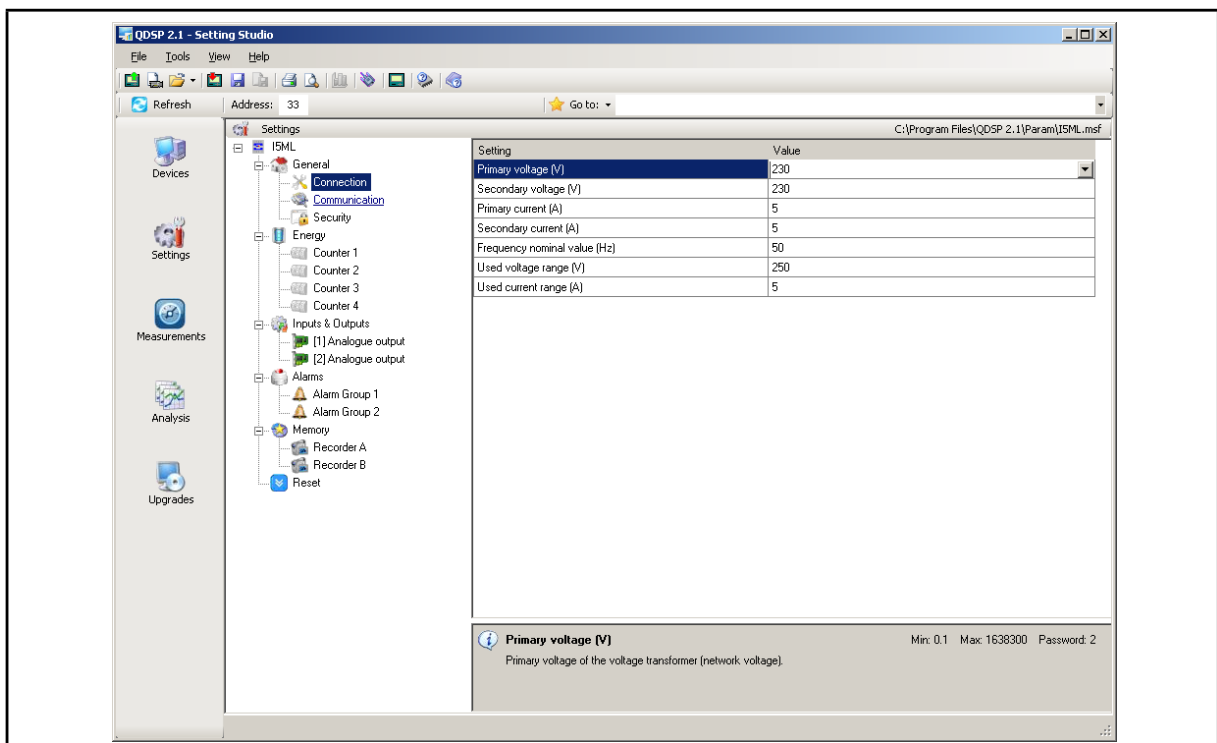

FIGURE 9-2: CONNECTION

8.5.1 Setting of current and voltage ratios

The details of the application must be known to define these settings; all other measurements depend on them. Values with up to 5 numerical digits and a maximum of 3 decimal places can be input.

Settings range	VT primary	VT secondary	CT primary	CT secondary
Maximum value	1638,3 kV	13383 V	1638,3 kA	13383 A
Minimum value	0,1 V	1 mV	0,1 A	1 mA

8.5.2 Used Voltage and Current Range

The setting of this range is connected with the setting of all alarms, analogue outputs and the display (calculation) of energy and measurement recording. Using a value that matches the expected measurement range (with overload) will achieve the highest quality of measurements.

If the 'Used' ranges are changed after the analogue or alarm settings have been defined, then the analogue and alarm settings will be modified automatically, as defined below. It may be necessary to modify the settings for the analogue and alarm outputs.

The 'Used' ranges are used to set the default scaling for the analogue output, which can be subsequently changed to meet the application requirements. Internally the analogue settings are also stored as a percentage of the 'Used' ranges. If the 'Used' ranges are subsequently changed the analogue output settings will be correspondingly changed to maintain the settings as the same percentage of the 'Used' range.

Although the alarm settings are defined in real values on QDSP, the alarms are also calculated as a percentage of the 'Used' range. If the 'Used' ranges are subsequently changed the alarm settings will be correspondingly changed to maintain the settings as the same percentage of the 'Used' range.

8.5.3 Nominal Frequency

A valid frequency measurement is within $\pm 32\text{Hz}$ of the nominal frequency. This setting is used for alarms and recorders and as a default value if the frequency value cannot be measured from the voltage or current input signals.

8.6 Communication

The settings displayed depend on the hardware options on the specific instrument connected or the settings in the specific settings file that is being worked on off-line.

8.6.1 Serial Communication parameters

These parameters are important for the correct operation in RS485 networks or connections with PC via RS232 communications. Factory settings for communication are #33\19200 (or 115200),n,8,2 (address 1 to 247\data rate 2400 to 115200 b/s, parity, data bits, stop bit).

8.6.2 Ethernet Communication

8.6.2.1 Device Address

The device address should be maintained at the default value of 33.

8.6.2.2 IP address

The communication interface should have a unique IP address in the Ethernet network. Two modes for assigning IP are described

- Fixed IP address: In most installations a fixed IP address is required. A system provider usually defines IP addresses. An IP address should be within a valid IP range, unique for your network and in the same sub-network as your PC.
- DHCP: An automatic method of assigning IP addresses (DHCP) is used in most networks. If you are not sure if DHCP is used on your network, check it with your system provider.

8.6.2.3 Local Port

Use a non-reserved port number from 1025 to 65535. Do not set the Local Port to any of the reserved port numbers.

If using Redirector software, the port number should be between 14000 and 14009.

Port numbers	Function
1 – 1024, 9999, 30718, 33333	Reserved numbers
14000 – 14009	Reserved for Redirector

Factory settings for Ethernet Communications are:

IP Address	DHCP (automatically)
TCP Port	10001
Subnet Mask	255.255.255.0

8.6.3 USB

The transducer will be identified as a USB device when connected to a USB port on the PC, refer to the separate QDSP manual for details of the driver installation.

8.7 Security

Parameter settings are divided into 2 groups for regarding security level:

1. If the passwords are set to 'AAAA' (default) there is no restriction to the access of parameter settings.
2. At the first level (PL1), the settings for the real time clock and the reset of the energy registers and MD can be accessed.
3. At the second level (PL2), access is given to all parameter settings.
4. A Backup password (BP) is used if the passwords at level 1 (PL1) and level2 (PL2) have been forgotten, and it differs for each device depending on the serial number of the instrument. The BP password is available from Technical Support and is entered instead of password PL1 and/or PL2. The serial number is stated on the product label or can be read with QDSP and must be supplied when requesting the BP.

8.7.1 Password setting

A password consists of four capital letters taken from the British alphabet from A to Z. When setting a password, only the letter being set is visible, while the others are covered with an asterisk.

Two passwords (PL1, PL2) and the time after which they become active, can be set.

8.7.2 Password modification

A password can be modified; however only the password whose access has been unlocked (password entered) can be modified.

To disable a password previously set, modify the password back to 'AAAA'.

8.8 Energy

The parameters defining the energy measurement and totalising can be modified. After modifications have been done the energy registers must be reset or all subsequent energy measurements will be incorrect.

8.8.1 Common Energy Exponent

The Common energy exponent defines the minimum energy value that can be displayed on the energy counter. On the basis of this and a counter divider, a basic calculation factor for

energy is defined (-3 is $10^{-3}Wh=mWh$, 4 is $10^4Wh = 10 kWh$). The Common energy exponent also affects the setting of pulse outputs and alarm outputs when the instrument is being used as an energy meter.

The Table below defines recommended values for the Common Energy exponent, where the counter divider is at its default value of 10.

Current Voltage	1 A	5 A	50 A	100 A	1000 A
110 V	-1	0	1	1	2
230 V	0	0	1	2	3
1000 V	0	1	2	3	4
30 kV	2	2	3	4	4*

* - Counter divider should be at least 100

8.8.2 Measured Energy

Each counter is enabled or disabled and can be configured to read any energy value from a drop down selection. The Energy counters can operate in all four quadrants; this is chosen using a graphical interface as shown in Figure 9-4.

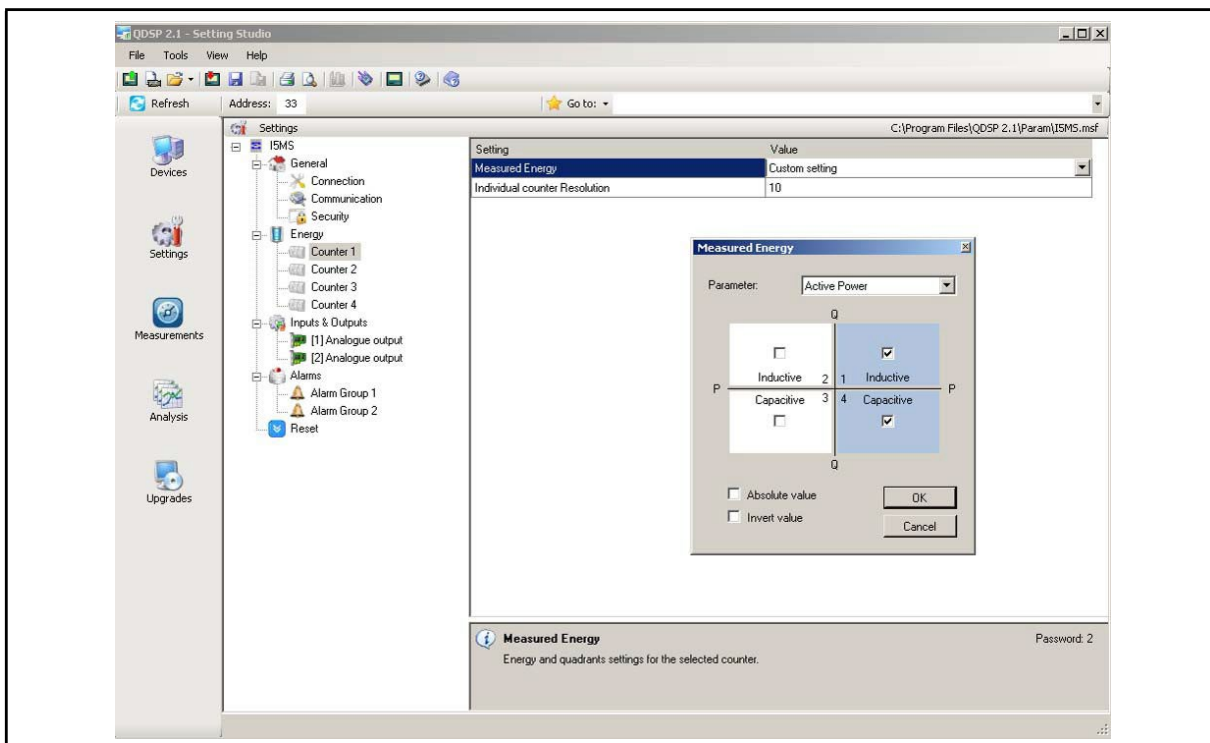

FIGURE 9-4 : MEASURED ENERGY

8.8.3 Counter Divider

The counter divider defines the precision of a specific counter, according to settings of the Common energy exponent.

An example for 12.345kW of consumed active energy in the first tariff (price 0.1567 €/kWh):

Common energy exponent	0	2	2
Counter divider	1	1	100
Example of result, display	12.345 kWh	12.3 kWh	0.01 MWh

8.9 Inputs and Outputs

The module settings displayed will depend on the I/O modules built in to the instrument or defined in the settings file if working off-line.

8.9.1 Analogue output module

Each of up to two analogue outputs is fully programmable.

8.9.1.1 Output parameter

Define the Measured or calculated parameter that is to be output on the specific analogue output.

8.9.1.2 Output range

The analogue output can be configured to one of six hardware output ranges within which the analogue output will operate. To ensure the highest accuracy for the output, the range selected should be the lowest that covers the required analogue output range.

DC current output	DC voltage output
-1...0...1 mA	-1...0...1 V
-5...0...5 mA	
-10...0...10 mA	-10...0...10 V
-20...0...20 mA	

8.9.1.3 Output Signal

This defines the actual range and output curve shape of the required analogue signal. Up to 5 break points can be programmed to achieve the required curve.

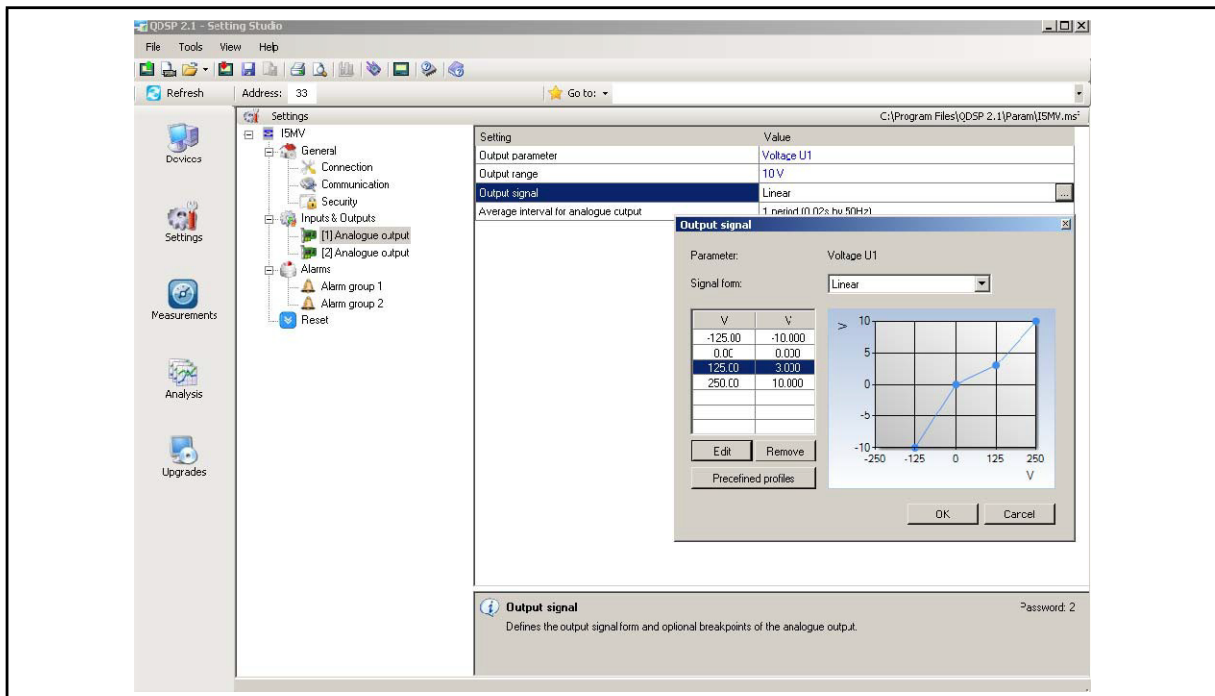

FIGURE 9-7: ANALOGUE OUTPUT SETTINGS

If the Analogue output signal is modified from the full linear range, the accuracy of the output may be reduced due to the reduction in the overall output range.

Note: If the 'Used' ranges are changed after the analogue settings have been defined, then the analogue settings will be modified automatically, see section 9.5.2. It may be necessary to subsequently modify the settings for the analogue outputs.

8.9.1.4 Average interval for analogue output

Defines the time interval over which the measurement used for an analogue output will be averaged.

8.9.2 Alarm/Digital Output Module

Alarm groups that are connected with an alarm module and a signal shape are defined

An alarm module can also function as a pulse output with limited pulse length (min 10ms) or a general purpose digital output. The settings for the pulse option are defined in the same way as for the pulse module. A parallel RC filter with a time constant of at least 150 μ s ($R \cdot C \geq 250 \mu$ s) should be fitted when connected to a sensitive pulse counter, to attenuate the relay transient signals.

8.9.2.1 Output signal

The alarm/digital output can be configured for a number of different signal shapes:

- Normal – The relay is closed until the alarm condition is fulfilled
- Normal Inverse – The relay is open until the alarm condition is fulfilled
- Holds – The relay is closed when the alarm condition is fulfilled, and remains closed until it is reset via communication.
- Pulse – an impulse of the defined length is sent when the alarm condition is fulfilled
- Always switched ON / OFF – The relay is switched ON or OFF irrespective of the alarm condition. This enables remote control via communication to be implemented.

8.9.3 Pulse Output Module

The pulse output module is either defined to an Energy counter or it can be used as an alarm output with limited current load (max 20mA).

When used as a pulse output the number of pulses per energy unit, pulse length and the tariffs in which the output is active are set.

Pulse parameters are defined in EN 62053 – 31, and the following is a simplified rule that satisfies the specification, where 'e' is multiplier.

$$1,5 \dots 15 \text{ eW} \rightarrow 100 \text{ p} \blacksquare 1 \text{ eWh}$$

Examples

Expected power	→	Pulse output settings
150 – 1500 kW	→	1 p/1kWh
1,5 – 15 MW	→	100 p/1MWh
15 – 150 MW	→	10 p/1MWh
150 – 1500 MW	→	1 p/1MWh

8.9.4 Digital Input module

There are no settings for the digital input; they operate by acting as an input to the Alarms 1 to 16. The input therefore can be used to trigger a software alarm and its status is available via the communications.

8.9.5 Watchdog Output module

The purpose is to detect potential malfunction of the transducer or auxiliary power supply failure. This module can be set for normal operation (relay in close position) or for test purposes to open position (manual activation). After test the module should be set back to normal operation.

8.10 Alarms

There are 16 alarms available split into 2 alarm groups. On the **i5ML** the alarm status can be recorded into recorder memory.

8.10.1 Alarm setting

For each of the 2 alarm groups a time constant of maximum values in thermal mode, a delay on time and alarm deactivation hysteresis can be defined.

For each individual alarm a parameter, value (actual value or MD- thermal) and the condition for alarm switching are defined. In addition it is defined if a relay is to be switched.

If a digital input module is fitted to the transducer, then the status of the input can be defined as the parameter.

Note: If the 'Used' ranges are changed after the alarm settings have been defined, then the alarm settings will be modified automatically, see section 9.5.2. It may be necessary to subsequently modify the settings for the alarm outputs.

8.10.2 Types of Alarm

8.10.2.1 Alarm Output (pulse)

According to the alarm signal shape the output relay will behave as shown in Figure 9-9.

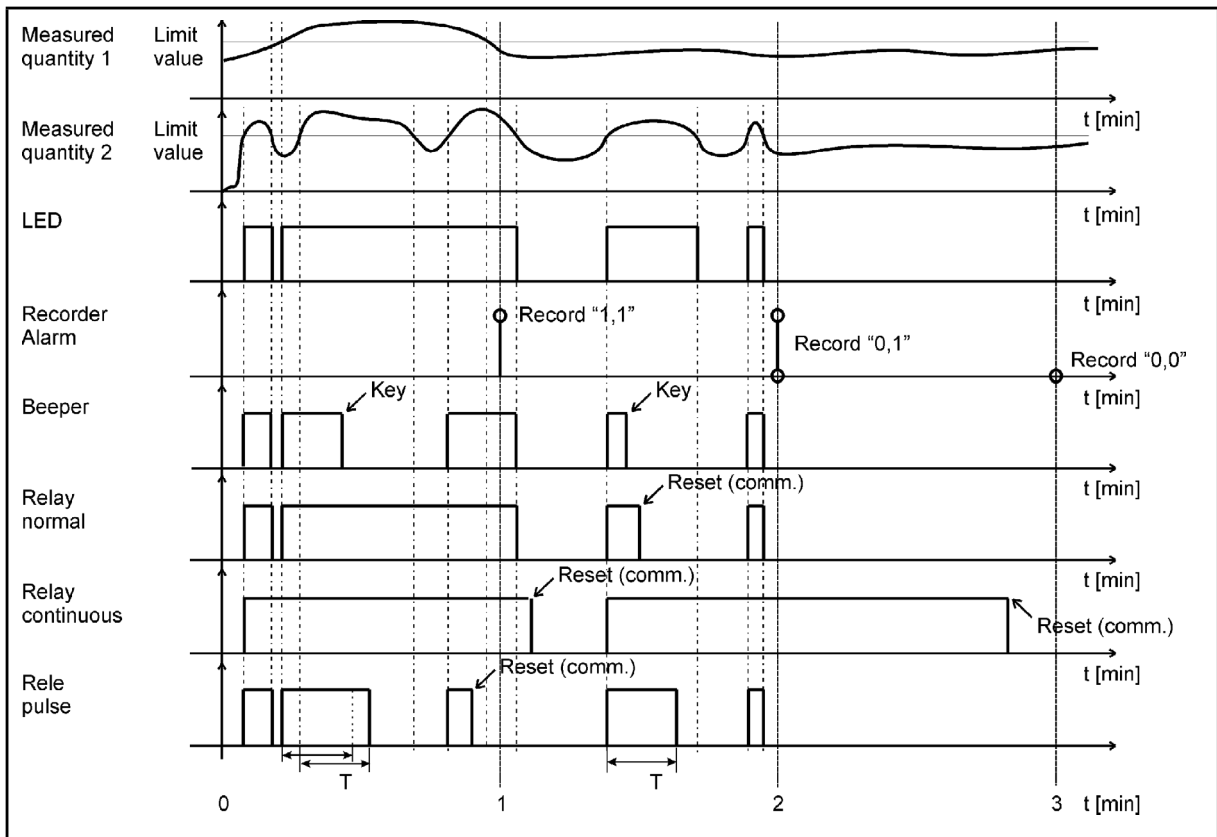

FIGURE 9-9 : ALARM OUTPUTS

8.11 Memory

Measurements, alarms, reports and details of supply voltage quality can be stored in the 8MB of internal memory on the **i5ML**. All records stored in the memory are accessible using QDSP.

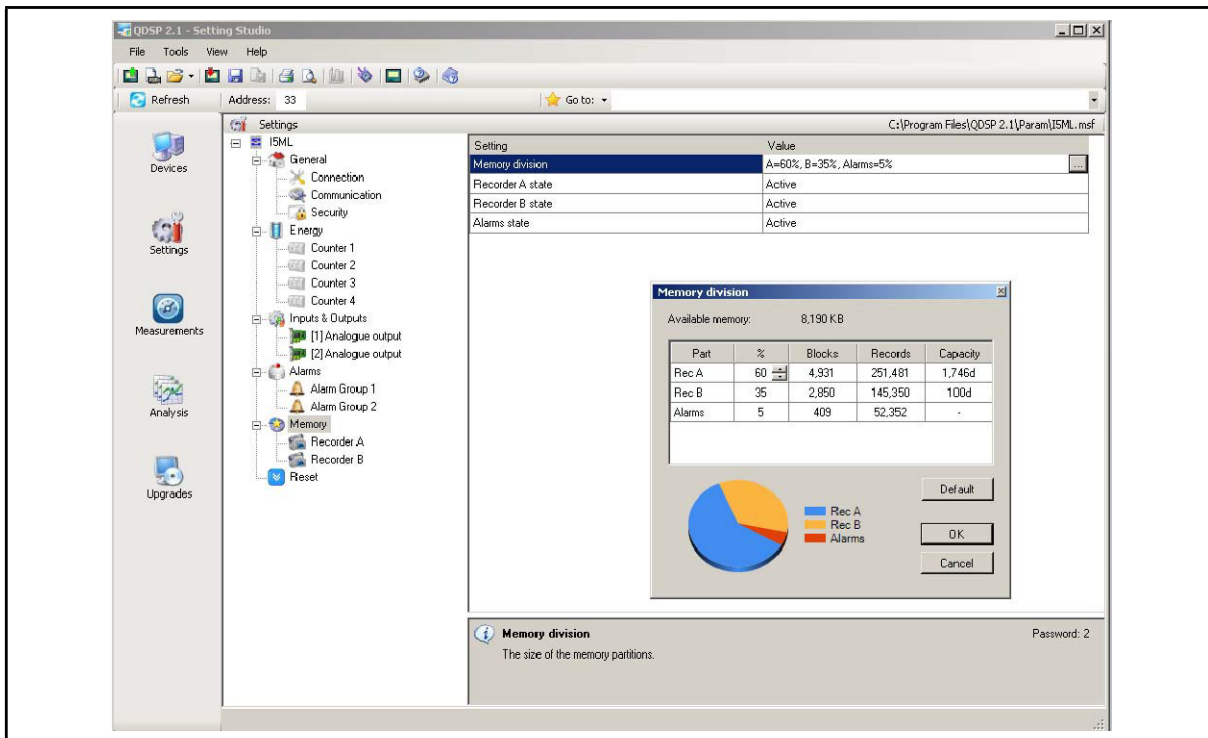

FIGURE 9-10 : MEMORY SETTINGS

8.11.1 Memory division

The internal memory is divided into 3 partitions, recorder A, recorder B and Alarms whose size can be defined by the customer, see Figure 9-10. The A and B recorders are intended for recording measurements, while alarms are recorded in a separate partition.

8.11.2 Memory Operation

Memory functions in a cyclic mode in compliance with the FIFO method. This means that only the latest records are stored in the memory and if necessary these will replace the oldest ones. The number of stored data records or the storage period depends on the selected partition size, the number of recorded quantities and sampling period.

8.11.3 Memory clearing

There is usually no need to clear the memory as it works in cyclic mode in FIFO method with the oldest records being overwritten when new records are stored. If you need to clear memory then follow these steps:

- Read the instrument readings with QDSP and set "Recorder state" in Memory to 'stopped'
- Download the changes to the device and open Memory info form and then click on Clear memory button.
- Select memory partitions to be cleared on Memory form and click OK.
- Set "Recorder state" setting back to 'Active'

8.12 Data Recorders

The **i5ML** has two data recorders A & B, which can only be configured using the QDSP software. These two recorders (A and B) are independent from each other and each can be

configured to record up to 8 different values. The Recorder sample time can be set between 1 and 255 minutes.

Figure 9-11 shows the QDSP Data Recorder menu. This shows the 8 different record values for each of the two recorders, each of which is configurable to any ac measurement.

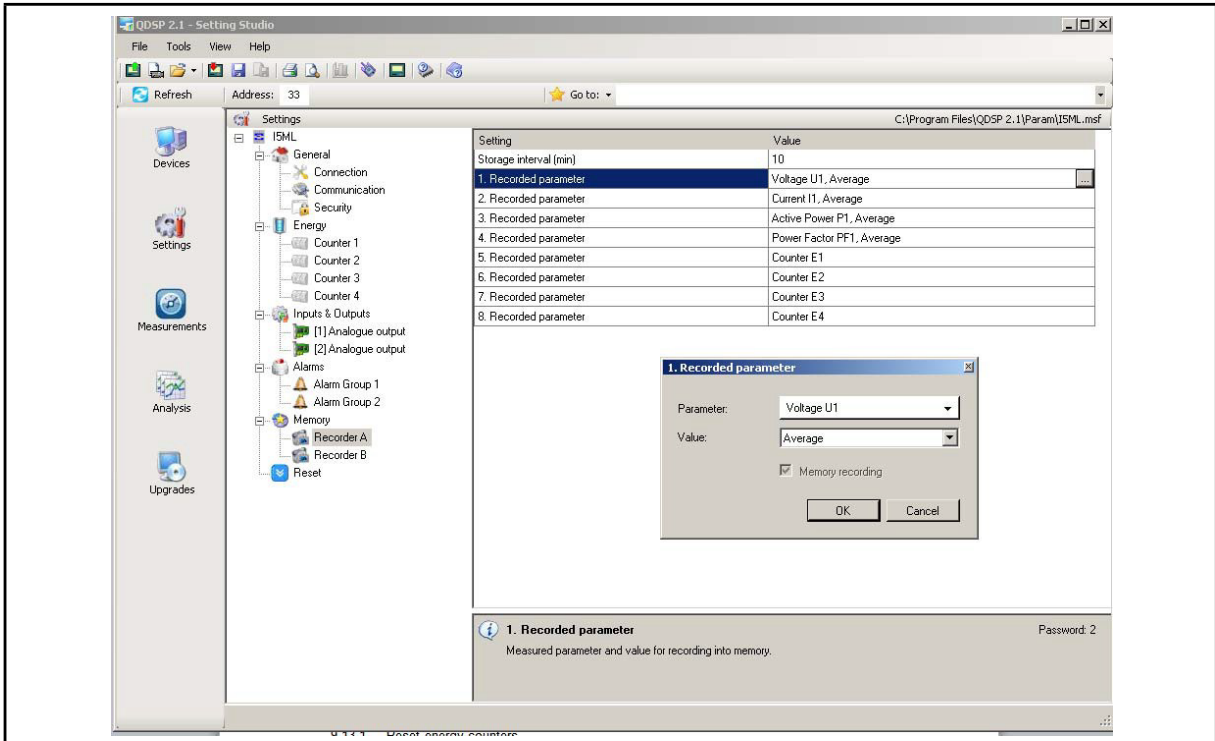

FIGURE 9-11 : DATA RECORDER

8.13 Reset Operations

8.13.1 Reset energy counters

All or individual energy counters are reset.

8.13.2 Reset maximal MD values

Current and stored MD's are reset.

8.13.3 Reset the last MD period

Current MD value is reset.

9. SYSTEM MODES

9.1 Connection mode

The connection mode is: 1b - single phase connection,

9.2 Power mode

The power mode is used for the signing of power measurements. The user cannot set the **I500** power mode. It is defined as follows:

- When active power is calculated, a positive value indicates export power (a consumer) whilst a negative value indicates import power (a generator).
- When reactive power is calculated, a positive value indicates an inductive load (a consumer) whilst a negative value indicates a capacitive load (a generator).

9.3 Operating energy quadrants

The operating energy quadrants are used to determine which types of energy are added to the energy counters. The user may modify the operating energy quadrants via the remote communications interface.

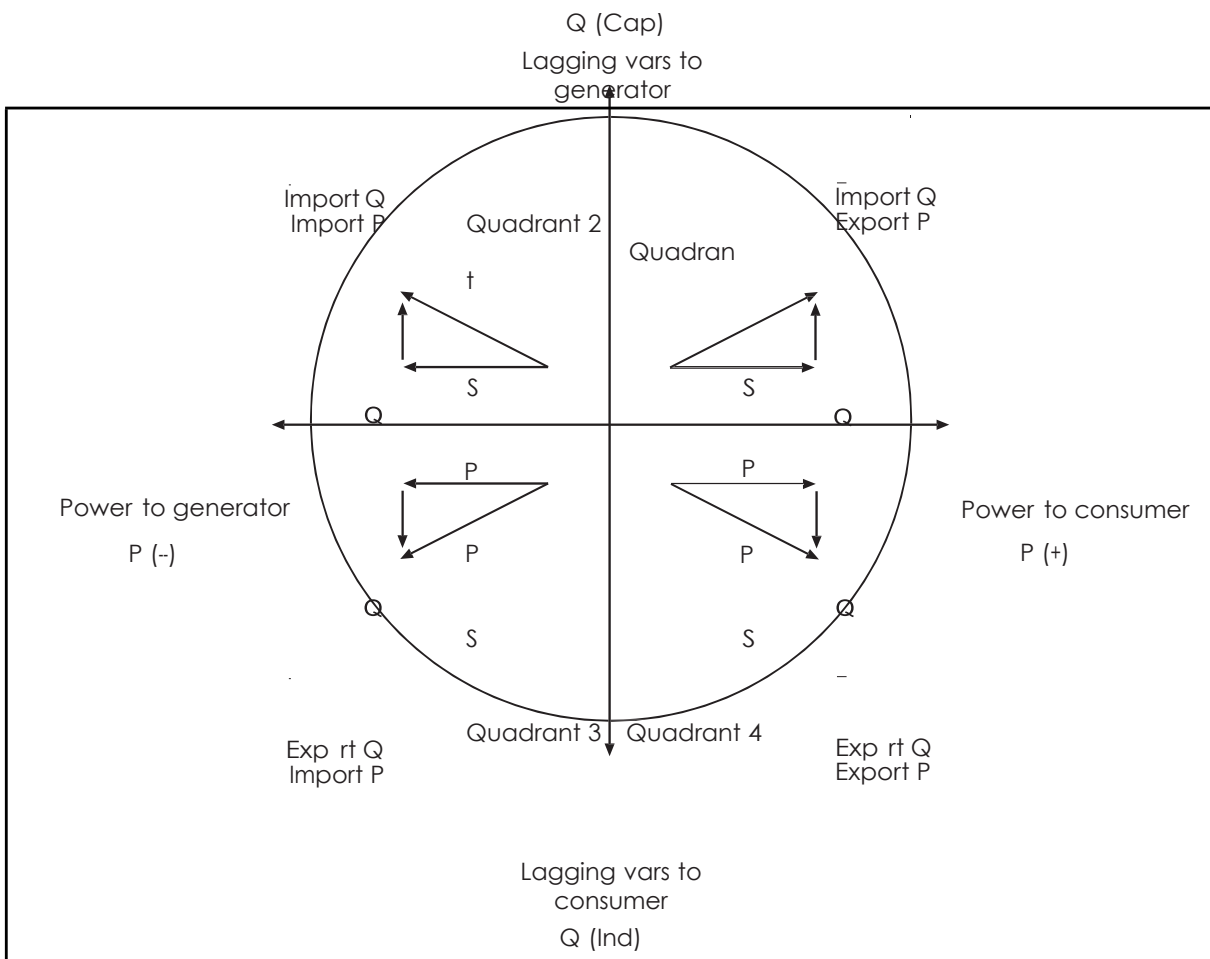

FIGURE 10-1 : POWER FLOW

10. INSTRUMENTATION

10.1 Measurements

With the increase in harmonics present in today's power systems, due to the increased use of electronic loads such as computers, variable frequency drives, etc. it is important, when accurate monitoring of electrical parameters is required, to use a measuring technique that allows for their presence. Conventional measurement methods, that use a mean sensing technique, respond to the mean or average of the input waveform. This is only accurate when the input waveform approaches a pure sinusoid.

The **I500** uses a true RMS (root-mean-square) measurement technique that provides accurate measurement with harmonics present up to the 53rd harmonic. The **I500** reads 128 samples per cycle and the true RMS measurement is obtained using these sampled values.

10.2 Glossary

The following terms and symbols are used:

TABLE 11-1 : SYMBOLS	
M _v	Sample factor
M _P	Averaging interval
U _f	Phase voltage (U ₁ , U ₂ or U ₃)
U _{ff}	Phase-to-phase voltage (U ₁₂ , U ₂₃ or U ₃₁)
N	Total number of samples in a period
n	Sample number (0 ≤ n ≤ N)
i _n	Current sample n
u _{fn}	Phase voltage sample n
φ _f	Power angle between current and phase voltage f (φ ₁ , φ ₂ or φ ₃)
U _c	Agreed supply voltage

TABLE 11-2 : GLOSSARY	
Term	Explanation
RMS	Root Mean Square value
Flash	Type of a memory module that keeps its content in case of power supply failure
Ethernet	IEEE 802.3 data layer protocol
MODBUS	Industrial protocols for data transmission
QDSP	Software for iSTAT family
AC	Alternating current
PA	Power angle (angle between current and voltage)
PF	Power factor
THD	Total harmonic distortion

TABLE 11-2 : GLOSSARY	
MD (maximum demand)	Measurement of average values in time interval
RTC	Real Time Clock
Sample factor (Mv)	Defines a number of periods for measuring calculation on the basis of measured frequency
Averaging interval (Mp)	Defines frequency of refreshing displayed measurements on the basis of a Sample factor

10.3 Supported Measurements

The measurements that the **I500** family supports will depend on the model selected and whether the measurements are available over the communications. The following table shows the measurements that are available on each version.

Basic measurements	i5ML	i5MS	i5MV	i5MC
Voltage U_1	•	•	•	
Current I_1	•	•		•
Active power P_1	•	•		
Reactive power Q_1	•	•		
Apparent power S_1	•	•		
Power factor PF_1	•	•		
Power angle ϕ_1	•	•		
THD of phase voltage U_{f1}	•	•	•	
THD of phase current I_1	•	•		•
Frequency	•	•	•	•
Internal temperature	•	•	•	•
Date & Time	•			
MD	•	•	•	•
Energy Counter 1	•	•		
Energy Counter 2	•	•		
Energy Counter 3	•	•		
Energy Counter 4	•	•		

10.3.1 Voltage

The **i5MC/MV/MS/ML** measure the true RMS value of the phase voltage (U) connected to the unit, average phase voltage (U_f) is calculated from these measured parameters.

$$U_f = \sqrt{\frac{\sum_{n=1}^N u_n^2}{N}}$$

V rms Phase calculation

N = 128 samples in one period (up to 65Hz)

N = 128 samples in M periods (above 65Hz),

eg at 400Hz, n=7

The available phase and average voltages (instantaneous, minimum and maximum values), can be viewed via the remote communications link.

10.3.2 Current

The **I500** measures the true RMS value of the currents connected to the unit.

$$I_{RMS} = \sqrt{\frac{\sum_{n=1}^N i_n^2}{N}}$$

I rms calculation

N = 128 samples in one period (up to 65Hz)

N = 128 samples in M periods (above 65Hz),

eg at 400Hz, n=7

10.3.3 Frequency

The system frequency is calculated from the time period of the measured voltage and can be viewed via the remote communications link..

10.3.4 Harmonics

The percentage total harmonic distortion (%THD) value is the ratio of the sum of the powers of the harmonic frequencies above the fundamental frequency to the power of the fundamental frequency. This sum of the powers is a geometric total, formed by taking the square root of the sum of the squares of the amplitude of each of the harmonics.

$I_f \text{THD}(\%) = \frac{\sqrt{\sum_{n=2}^{63} I_n^2}}{I_1} \cdot 100$
<p>Current THD calculation I1 = value of first harmonic N = number of harmonic</p>
$U_f \text{THD}(\%) = \frac{\sqrt{\sum_{n=2}^{63} U_n^2}}{U_1} \cdot 100$
<p>Phase Voltage THD calculation U1 = value of first harmonic N = number of harmonic</p>

10.4 Power, power factor and energy

10.4.1 Power

The **I500** provides accurate measurement of active (P), reactive (Q) and apparent power (S).

- Active power.

$P = \frac{1}{N} \cdot \sum_{n=1}^N (u_n \times i_n)$
<p>Active Power N = number of periods n = number of samples in a period</p>

- Reactive power.

$Q = \text{Sign}Q(\phi) \times \sqrt{S^2 - P^2}$
<p>Reactive Power S = apparent power P = active power</p>

- Apparent power.

$S = U \times I$
<p>Apparent Power Uf = phase voltage If = phase current</p>

- Power direction.

When displaying active power, a positive sign indicates export power (a consumer) whilst a negative sign indicates import power (a generator).

When displaying reactive power, a coil symbol indicates an inductive load (a consumer) whilst a capacitor symbol indicates a capacitive load (a generator).

$SignQ_f(\varphi)$ $\varphi \in [0^\circ - 180^\circ] \Rightarrow SignQ_f(\varphi) = +1$ <hr style="border: 0.5px solid black;"/> $\varphi \in [180^\circ - 360^\circ] \Rightarrow SignQ_f(\varphi) = -1$ <p>Reactive Power direction Q_f – reactive power φ – power angle</p>

10.4.2 Power factor

$PF = \frac{P}{S}$
Power Factor

10.4.3 Energy

Four counters are available so that energy in each of the four quadrants can be measured. The configuration of the four counters can be adapted to the customer's needs using QDSP..

10.4.4 Maximum demands (MDs)

The instrument provides maximum demand values from the thermal demand values.

10.4.4.1 Thermal Demand

The thermal demand option will provides an exponential thermal characteristic, based on the bimetal element principal.

A time constant (t. c.) can be set from 1 to 255 minutes and is 6–time thermal time constant (t.c. = 6 * thermal time constant).

Example:

Mode: Thermal function

Time constant: 8 min.

Current MD and maximal MD: Reset at 0 min.

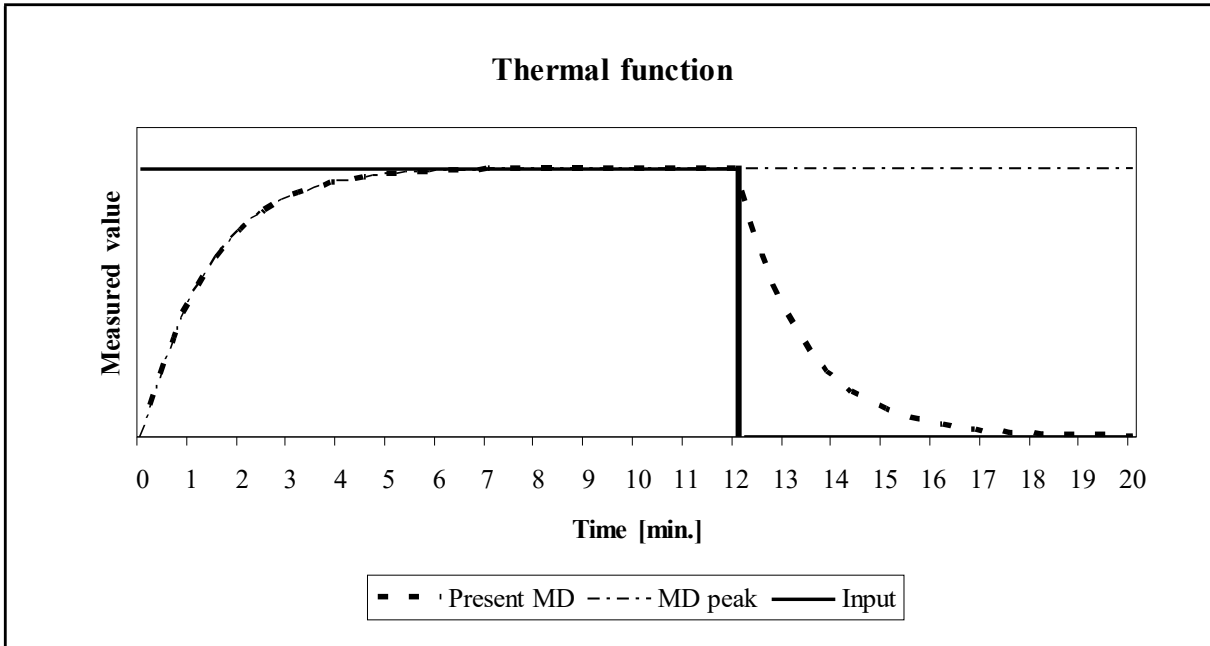

11. COMMUNICATIONS

11.1 Communications ports

The **i5MC/MV/MS/ML** are fitted with a communications port (COM1).

COM1 can be RS232/RS485, USB, or Ethernet and USB

The communications port can be used for settings and the monitoring of data.

The communication parameters of the **i500** can be obtained by using the 'Scan the network' feature in the QDSP setting software.

11.2 QDSP Setting and Monitoring Software

See the separate QDSP Manual for details of how to Install and use the QDSP Software.

11.3 MODBUS

For details, see the separate M2x3 & I500 Communications Manual.

12. BATTERY REPLACEMENT

The **i5ML** contains a lithium battery. It is used to preserve data (date and time) in the device memory when the power supply is off. Life time of battery is approximately 6 years (typical) but high temperatures and humidity can shorten the battery's life.

The Battery has no effect on any functionality of the device, except date and time.

It is recommended that the instrument is sent back in the factory for battery replacement. It is possible that the replacement can be made by a qualified person, but in this case GE Grid Solutions does not take any responsibility for any injuries, malfunction of the instrument or mechanical damage.

Instructions for replacement

1. Disconnect the instrument from measuring grid and power supply (Caution! - Read the safety section!) and take it off the mounting rail..
2. With flat blade screwdriver remove the cover [3] from instrument [1] (see picture 13.1)
3. Remove PCB assembly [2] from case [1] (Read section on 'HANDLING OF ELECTRONIC EQUIPMENT')
4. Remove the battery from its holder on the PCB, and replace it with the same model (Varta, type 6032 CR2032 SLF)
5. To put the instrument together follow steps 2 to 3 in reverse order
6. Set device date and time.

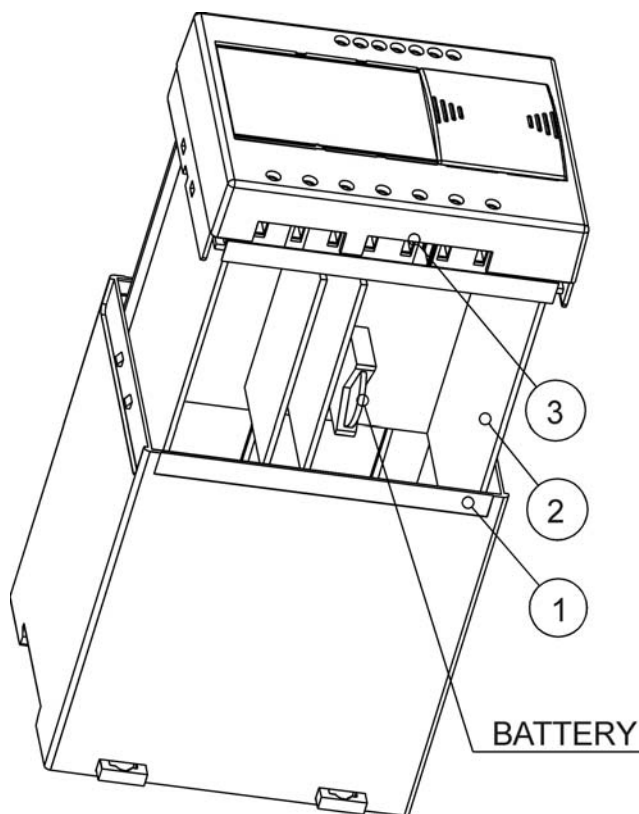

FIGURE 13-1: BATTERY REPLACEMENT

13. TECHNICAL DATA

INPUTS AND SUPPLY		
Voltage Input	Rated Voltage (Un)	57.7.....230 V _{LN}
	Rating	45V/277V _{LN}
	Max. allowed value	277 V _{LN} permanently 2 x Un for 10 seconds
	Minimum range	2 V sinusoidal
	Burden	<0.1 VA per phase
Current Input	Rated current (In)	0.31....5A
	Rating	1A/5A
	Overload (thermal)	15A continuously 20 x In (5 x 1s)
	Minimal range	Set Starting current for power
	Maximum range	12.5A sinusoidal
	Burden	<0.3 VA
Frequency	Nominal Frequency (Fn)	50/ 60Hz
	Measuring range	16 to 400Hz
	Maximum range	10 to 1000 Hz
Power Supply - Universal High	AC voltage range	80 to 276Vac
	Frequency range	40 to 70Hz
	DC voltage range	70 to 300Vdc
	Burden	<5VA
	Power on transient current	< 20A 1ms
Power Supply - Universal Low	AC voltage range	45 to 77Vac
	Frequency range	40 to 70Hz
	DC voltage range	19 to 70Vdc
	Burden	<5VA
	Power on transient current	< 20A 1ms
Battery (i5ML)	Type	CR2032 Li battery
	Nominal voltage	3V
	Life	Approx 6 years @ 23C

CONNECTIONS	
Permitted conductor cross sections	Conductor cross section
Voltage terminals	0.325 ... 2.5 mm ² (22 – 14 AWG) one conductor
Current terminals	0.325 ... 2.5 mm ² (22 – 14 AWG) one conductor
Supply	0.325 ... 2.5 mm ² (22 – 14 AWG) one conductor
I/O Modules and Communications	0.325 ... 2.5 mm ² (22 – 14 AWG) one conductor
Volts, currents and supply: Ring terminal version	M4 connection tag

ACCURACY		
RMS Current I1	1A	Class 0.2 (0.1**)
	5A	Class 0.2 (0.1**)
RMS Line Voltage U1	75V L-N	Class 0.2 (0.1**)
	250V L-N	Class 0.2 (0.1**)
	500V L-N	Class 0.2 (0.1**)
Frequency F - actual	50Hz/60Hz	Class 0.02
Nominal frequency range	16...400 Hz	Class 0.02
Power Angle (φ)	Calculated from U and I	0.1°
Power Factor	-1...0...+1	
	U = 50 ... 120 % U_n	Class 0.5
	I = 2 % ... 20 % I_n I = 20 % ... 200 % I_n	Class 0.1
Maximum Demand	Calculated from U and I	Class 1
THD	5...500 V	
	0.1...10A	Class 0.5
	0...400 %	
Power		
Active power (W) ;P	Calculated from U and I	Class 0.2 (0.15**)
Reactive power (var): Q, Apparent power (VA) : S	Calculated from U and I	Class 0.2 (0.15**)
Energy		
Active W	Calculated from U and I	Class 0.5S to EN 62053-22
Reactive VA	Calculated from U and I	Class 2 to EN 62053-23
Real Time clock		1minute per month (30ppm)
Analogue output (internal supply)	-20...+20 mA	$\pm 20 \mu\text{A}$
	-10...+10 V	$\pm 10\text{mV}$

Total accuracy (measurements and analogue output) according to IEC/EN 60688. Accuracy is defined as percentage of reading of the measurement except when it is stated as an absolute value.

(** - accuracy on communications)

I/O MODULES		
Alarm & Watchdog output	Contact rating	48 Vac/dc (+40% max)
	Maximum switching current	1000 mA
	Insulation	1000V ac between open contacts
		4000V ac between coil and contacts
	Pulse (Alarm Output)	Max 4000 per/hour, Minimum width 100ms
Pulse output (solid state)	Maximum switching	40 Vac/dc, 30mA
	Pulse length	Programmable 2 to 1000 ms
Digital input	Voltage	48 Vac/dc (+40% max)
	Current	< 0.6 mA
	Minimum signal width	20ms
	Minimum pause width	40ms
	SET voltage	40120% of rated voltage
	RESET voltage	010% of rated voltage

ANALOGUE		
General	Linearization	Linear, Quadratic
	No. of break points	5
	Output value limits	± 120% of nominal output
	Response time	Input → output < 100 ms
	Residual ripple	< 0.5 % p.p.
DC Current output	Output range values	-100...0...100%
	-1...0...1 mA	Range 1
	-5...0...5 mA	Range 2
	-10...0...10 mA	Range 3
	-20...0...20 mA	Range 4
	Other ranges	Programmable using QDSP
	Burden voltage	10 V
	External resistance	$RB_{max} = 10 V / I_{outN}$
DC Voltage output	Output range values	-100...0...100%
	-1...0...1 V	Range 5
	-10...0...10 V	Range 6
	Other ranges	Programmable using QDSP
	Burden current	5 mA
	External resistance	$RB_{min} = U_{outN} / 5 mA$

COMMUNICATION				
	Ethernet	USB	RS232	RS485
Connection	Network	Direct	Direct	Network
Max connection length	-	-	3M	1000M
Terminals	RJ45	USB-B	DB9 female	DB9 female and terminals
Transmission mode	Asynchronous			
Protocol	MODBUS TCP	MODBUS RTU		
Insulation	2.2KV, 1minute between terminals and all other circuits			
Transfer rate	10/100Mb/s (autodetect)	USB 2.0	1200 to 115200b/s	

ELECTRONIC FEATURES		
Response time	Input to communications	Calculated during averaging interval setting (8 to 256 periods), resetting (64 periods) typically 1.28 seconds at 50Hz
Memory	i5ML	8MB (recorder A, recorder B, alarm recorder)
Status LED's	Green	Communications in progress
	Red	Instrument power ON

SAFETY FEATURES		
General	Protective earth terminal due to touchable metal parts (USB-B, RJ-45, DB9), current limiting fuse 0,5A on aux. Supply (L terminal) Voltage inputs via high impedance Double insulation on I/O ports and communications port	
Protection Class	1	
Installation category	CAT III: 600Vrms, Measurement Inputs CAT III: 300Vrms, Auxiliary Supply In compliance with EN61010-1:2002	
Pollution degree	2	
Test voltage	U _{AUX↔I/O, COM1} : 2210 VAC _{rms} U _{AUX↔U, I inputs} : 3320 VAC _{rms} U, I inputs↔I/O, COM1,2: 3320 VAC _{rms} U inputs↔I inputs: 3320 VAC _{rms}	
EMC	Directive on electromagnetic compatibility 2004/108/EC In compliance with EN 61000-6-2:2005 and EN 61000-6-4:2002	
Protection	In compliance with EN60529:1997 IP40 (IP20 for terminals)	
Ambient conditions	Climatic	Usage group II
	Ambient Temperature	0...15...30...55°C Acc. To IEC/EN 60688
	Temperature	Operation -30 to +70C Storage -40 to +70C
	Humidity	≤ 93%RH non condensing
Enclosure	Material	PC/ABS incombustibility – self extinguishing in compliance with UL94VO
	Protection	In compliance with EN60529:1997 IP40 (IP20 for terminals)
	Mounting	Rail mounting 35 × 7.5 mm acc. to DIN EN 50 022
	Dimensions	100 × 127 × 75 mm
	Weight	375g

14. WIRING DIAGRAMS

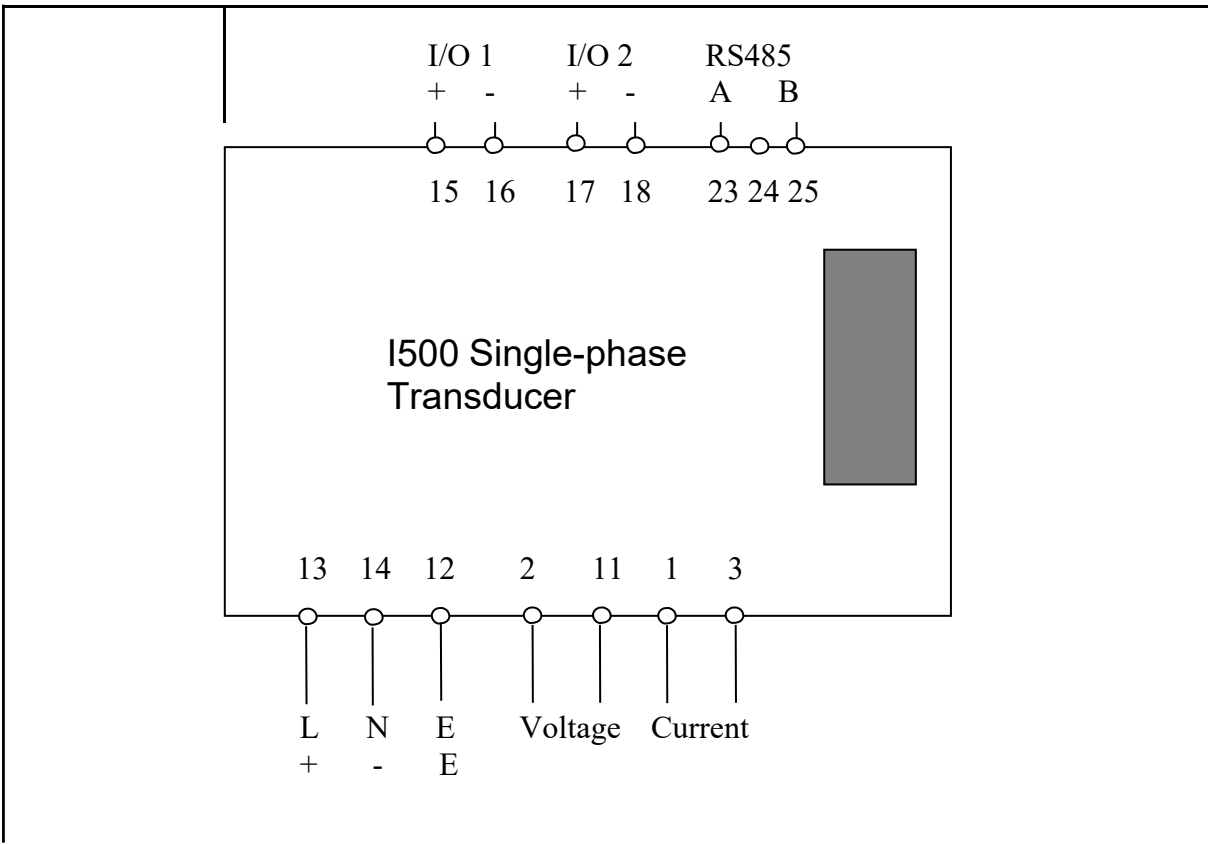

FIGURE 15-1 : CONNECTION DIAGRAM

System/ connection	Terminal assignment
<p>Connection 1b (1W)</p> <p>Single-phase connection</p> <p>i5MS, i5ML</p>	

System/ connection	Terminal assignment
<p>Connection 1b (1W)</p> <p>Single-phase connection</p> <p>Voltage Only</p> <p>i5MV</p>	
<p>Connection 1b (1W)</p> <p>Single-phase connection</p> <p>Current Only</p> <p>i5MC</p>	

FIGURE 15-2 : EXTERNAL WIRING DIAGRAM: SINGLE PHASE (1B)

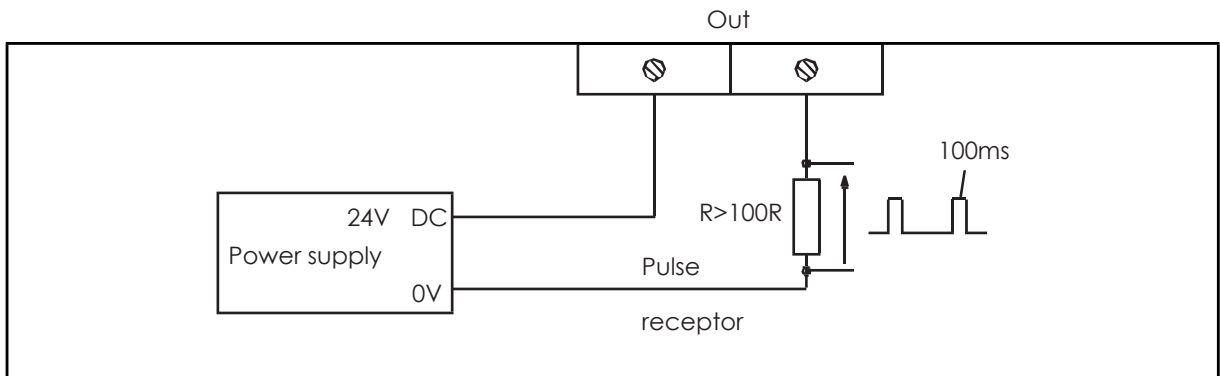

FIGURE 15-3 : TYPICAL CONNECTIONS FOR PULSE OUTPUT

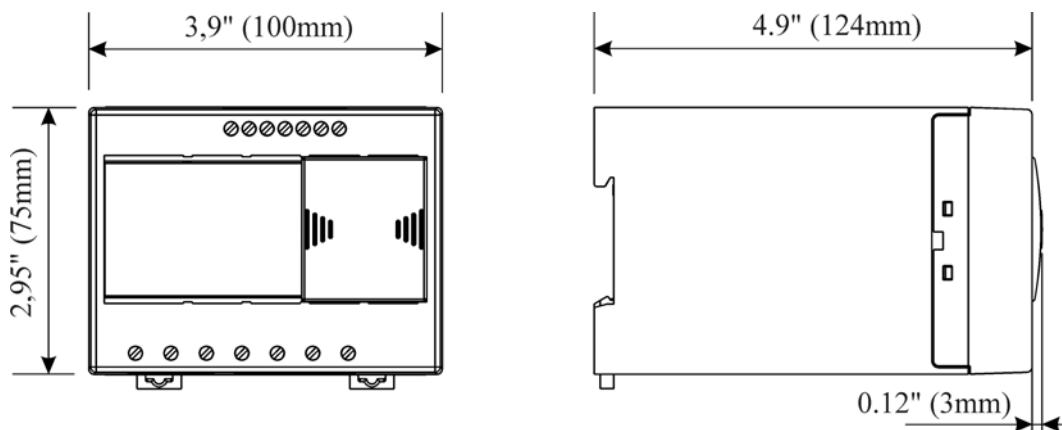

FIGURE 15-4 : ENCLOSURE DIMENSIONS

15. RELATED DOCUMENTS

Ref	Document
1	1500 and M2x3 Communications Manual
2	QDSP Technical Manual



GE VERNOVA

GE Vernova
St Leonards Building
Redhill Business Park
Stafford, ST16 1WT, UK
+44 (0) 1785 250 070
www.governova.com/grid-solutions/contact.htm

© 2025 GE Vernova. All rights reserved. Information contained in this document is indicative only.
No representation or warranty is given or should be relied on that it is complete or correct or will apply to any particular project.
This will depend on the technical and commercial circumstances. It is provided without liability and is subject to change without
notice. Reproduction, use or disclosure to third parties, without express written authority, is strictly prohibited.

I500SP/EN/M/D