

GE Vernova  
Grid Solutions

# iSTAT M2x3

## Enhanced Measurement Centre

### M203, M213, M233, M243, M253

Manual

Publication reference: iSTAT M2x3/EN/M/G



GE VERNOVA



## 1. SAFETY SECTION





This Safety Section should be read before commencing any work on the equipment.

### 1.1 Health and Safety

The information in the Safety Section of the product documentation is intended to ensure that products are properly installed and handled to maintain them in a safe condition. It is assumed that everyone who will be associated with the equipment will be familiar with the contents of the Safety Section.

### 1.2 Explanation of Symbols and Labels

The meaning of symbols and labels may be used on the equipment or in the product documentation, is given below.

	
Caution: refer to product documentation	Caution: risk of electric shock
	
Protective/safety *earth terminal	Functional *earth terminal Note: This symbol may also be used for a protective/safety earth terminal if that terminal is part of a terminal block or sub-assembly e.g. power supply.

\*NOTE: The term earth used throughout the product documentation is the direct equivalent of the North American term ground.

---

## 2. INSTALLING, COMMISSIONING AND SERVICING



### Equipment connections

Personnel undertaking installation, commissioning or servicing work on this equipment should be aware of the correct working procedures to ensure safety. The product documentation should be consulted before installing, commissioning, or servicing the equipment.

Terminals exposed during installation, commissioning and maintenance may present a hazardous voltage unless the equipment is electrically isolated.

If there is unlocked access to the rear of the equipment, care should be taken by all personnel to avoid electrical shock or energy hazards.

Voltage and current connections should be made using insulated crimp terminations to ensure that terminal block insulation requirements are maintained for safety. To ensure that wires are correctly terminated the correct crimp terminal and tool for the wire size should be used.

Before energising the equipment, it must be earthed using the protective earth terminal, or the appropriate termination of the supply plug in the case of plug connected equipment. Omitting or disconnecting the equipment earth may cause a safety hazard.

The recommended minimum earth wire size is 2.5mm<sup>2</sup>, unless otherwise stated in the technical data section of the product documentation.

Before energising the equipment, the following should be checked:

- Voltage rating, frequency, and polarity
- VT ratio and phase sequence
- CT circuit rating and integrity of connections
- Protective fuse rating
- Integrity of earth connection (where applicable)
- Supply voltage

---

### 3. EQUIPMENT OPERATING CONDITIONS

The equipment should be operated within the specified electrical and environmental limits.

#### 3.1 Current Transformer Circuits



Do not open the secondary circuit of a live CT since the high level voltage produced may be lethal to personnel and could damage insulation.

#### 3.2 Battery Replacement



Where internal batteries are fitted, they should be replaced with the recommended type and be installed with the correct polarity, to avoid possible damage to the equipment. The M233, M243 and M253 may have a Varta CR2032 SLF or equivalent fitted with an estimated life of 6 years.

#### 3.3 Insulation and Dielectric Strength Testing



Insulation testing may leave capacitors charged up to a hazardous voltage. At the end of each part of the test, the voltage should be gradually reduced to zero, to discharge capacitors, before the test leads are disconnected.

#### 3.4 Opening Enclosure



There are no customer replaceable PCB cards or components within the enclosure, so the enclosure should not be opened.

---

### 4. DECOMMISSIONING AND DISPOSAL



**Decommissioning:** The auxiliary supply circuit in the relay may include capacitors across the supply or to earth. To avoid electric shock or energy hazards, after completely isolating the supplies to the relay (both poles of any dc supply), the capacitors should be safely discharged via the external terminals prior to decommissioning.

**Disposal:** It is recommended that incineration and disposal to water courses is avoided. The product should be disposed of in a safe manner. Any products containing batteries should have them removed before disposal, taking precautions to avoid short circuits. Regulations within the country of operation, may apply to the disposal of lithium batteries.

## 5. TECHNICAL SPECIFICATIONS

### 5.1 Protective Fuse Rating

The recommended maximum rating of the external protective fuse for this equipment is 6A, Red Spot type or equivalent, unless otherwise stated in the technical data section of the product documentation.

Insulation Class:	IEC 61010-1 : 2002 Class II EN 61010-1 : 2002 Class II	
Insulation Category (Over voltage):	IEC 61010-1 : 2002 Category II (600V), III (300V) EN 61010-1 : 2002 Category II (600V), III (300V)	
Environment:	IEC 61010-1 : 2002 Pollution degree 2 (600V), 3 (300V) EN 61010-1 : 2002 Pollution degree 2 (600V), 3 (300V)	Compliance is demonstrated by reference to generic safety standards.
Product Safety: 	2006/95/EC  EN 61010-1 : 2002	Compliance with the European Commission Low Voltage Directive.  Compliance is demonstrated by reference to generic safety standards.

# CONTENT

<b>1.</b>	<b>SAFETY SECTION</b>	<b>1</b>
1.1	Health and Safety	1
1.2	Explanation of Symbols and Labels	1
<b>2.</b>	<b>INSTALLING, COMMISSIONING AND SERVICING</b>	<b>2</b>
<b>3.</b>	<b>EQUIPMENT OPERATING CONDITIONS</b>	<b>3</b>
3.1	Current Transformer Circuits	3
3.2	Battery Replacement	3
3.3	Insulation and Dielectric Strength Testing	3
3.4	Opening Enclosure	3
<b>4.</b>	<b>DECOMMISSIONING AND DISPOSAL</b>	<b>3</b>
<b>5.</b>	<b>TECHNICAL SPECIFICATIONS</b>	<b>4</b>
5.1	Protective Fuse Rating	4
<b>6.</b>	<b>INTRODUCTION</b>	<b>11</b>
6.1	General	11
6.2	Family	12
6.3	Measurements	13
6.4	Hardware Features	13
6.5	Communication and Inputs/Outputs	14
6.6	User Features	15
6.7	Applications	15
<b>7.</b>	<b>SYSTEM MODES</b>	<b>17</b>
7.1	Connection Mode	17
7.1.1	Valid measurements	17
7.2	Power Mode	20
7.3	Operating Energy Quadrants	20
<b>8.</b>	<b>INSTRUMENTATION</b>	<b>22</b>
8.1	Measurements	22
8.2	Glossary	22
8.3	Supported Measurements	23

8.3.1	Voltage	25
8.3.2	Current	26
8.3.3	Angles between phases	26
8.3.4	Frequency	26
8.3.5	Harmonics	26
<b>8.4</b>	<b>Power, Power Factor and Energy</b>	<b>27</b>
8.4.1	Power	27
8.4.2	Power factor	29
8.4.3	Energy	29
8.4.4	Demand measurements	30
8.4.5	Real time clock (energy clock)	30
8.4.6	Maximum demands (MDs)	30
8.4.7	Average demands	30
<b>8.5</b>	<b>Power Quality</b>	<b>33</b>
8.5.1	Frequency and voltage variations	33
8.5.2	Voltage interruptions and dips	33
8.5.3	Fast voltage changes	33
8.5.4	Flicker - short term	33
8.5.5	Flicker - long term	34
<b>9.</b>	<b>HARDWARE</b>	<b>35</b>
<b>9.1</b>	<b>Communications</b>	<b>35</b>
9.1.1	RS232 /RS485 communications	35
9.1.2	Ethernet communications	36
9.1.3	USB communications	36
<b>9.2</b>	<b>Inputs and Outputs</b>	<b>36</b>
9.2.1	Energy pulse outputs	37
9.2.2	Tariff (inputs)	37
9.2.3	Alarm and bistable contacts (outputs)	38
9.2.4	Analogue (outputs)	38
9.2.5	Digital inputs	39
9.2.6	Watchdog output and alarm output (combined)	39
9.2.7	Analogue input	39
9.2.8	Pulse input	40
9.2.9	2 <sup>nd</sup> RS485 communications (COM2)	40
9.2.10	2 <sup>nd</sup> RS232 communications (COM2)	40
<b>9.3</b>	<b>Memory Card</b>	<b>41</b>
<b>9.4</b>	<b>Auxiliary Supply</b>	<b>41</b>
9.4.1	Inputs and supply	42
<b>10.</b>	<b>PROGRAMMING THE M2X3</b>	<b>43</b>
<b>10.1</b>	<b>Menu Introduction</b>	<b>43</b>
<b>10.2</b>	<b>Measurement Navigation</b>	<b>44</b>

<b>10.3</b>	<b>Settings Navigation</b>	<b>47</b>
<b>10.4</b>	<b>Resets Navigation</b>	<b>49</b>
<b>10.5</b>	<b>Memory Card Navigation</b>	<b>49</b>
<b>10.6</b>	<b>Info Navigation</b>	<b>50</b>
<b>10.7</b>	<b>Installation Navigation</b>	<b>51</b>
<hr/>		
<b>11.</b>	<b>MEASUREMENT MENU FUNCTIONS</b>	<b>52</b>
<b>11.1</b>	<b>Installation Wizard</b>	<b>52</b>
<b>11.2</b>	<b>Demo Cycling</b>	<b>55</b>
<b>11.3</b>	<b>Graphical Display</b>	<b>56</b>
<b>11.4</b>	<b>Cost Energy Management</b>	<b>57</b>
<b>11.5</b>	<b>Power Quality Recorder Report</b>	<b>58</b>
<hr/>		
<b>12.</b>	<b>M2X3 SETTINGS USING KEYPAD/DISPLAY</b>	<b>61</b>
<b>12.1</b>	<b>Setting Navigation</b>	<b>61</b>
<b>12.2</b>	<b>General Navigation</b>	<b>61</b>
<b>12.3</b>	<b>Date and Time Navigation</b>	<b>64</b>
<b>12.4</b>	<b>LCD Navigation</b>	<b>65</b>
<b>12.5</b>	<b>Security Navigation</b>	<b>66</b>
<b>12.6</b>	<b>Inputs and Outputs</b>	<b>67</b>
<hr/>		
<b>13.</b>	<b>M2X3 SETTINGS USING QDSP SOFTWARE</b>	<b>69</b>
<b>13.1</b>	<b>Introduction</b>	<b>69</b>
<b>13.2</b>	<b>QDSP Software</b>	<b>69</b>
13.2.1	Devices management	69
13.2.2	Instrument settings	69
13.2.3	Real time measurements	69
13.2.4	Data analysis	69
13.2.5	Software upgrading	69
<b>13.3</b>	<b>Setting Procedure</b>	<b>69</b>
<b>13.4</b>	<b>General Settings</b>	<b>70</b>
13.4.1	Description and location	70
13.4.2	Average interval	70
13.4.3	Currency (KD)	70
13.4.4	Temperature unit (KD)	70
13.4.5	Date format (KD)	70
13.4.6	Date and time (KD)	70
13.4.7	Auto summer/wintertime (KD)	71
13.4.8	Maximum demand calculation (MD mode) (KD)	71
13.4.9	Resetting min/max (KD)	71
13.4.10	Starting current for PF and PA (mA)	71
13.4.11	Starting current for all powers (mA)	71

13.4.12	Calculation of harmonics	71
13.4.13	Reactive power calculation	71
<b>13.5</b>	<b>Connection</b>	<b>72</b>
13.5.1	Connection (KD)	72
13.5.2	Setting of current and voltage ratios (KD)	72
13.5.3	Used voltage and current range	72
13.5.4	Nominal frequency	73
<b>13.6</b>	<b>Communication</b>	<b>73</b>
13.6.1	Serial communication parameters (COM1) (KD)	73
13.6.2	Ethernet communication	73
13.6.3	USB	74
<b>13.7</b>	<b>Security</b>	<b>74</b>
13.7.1	Password setting (KD)	74
13.7.2	Password modification (KD)	74
<b>13.8</b>	<b>Energy</b>	<b>74</b>
13.8.1	Active tariff (KD)	75
13.8.2	Common energy exponent	75
13.8.3	Common exponent of energy cost	75
13.8.4	Common exponent of tariff price and energy price in tariffs	75
13.8.5	Measured energy	75
13.8.6	Counter divider	76
13.8.7	Tariff selector	76
13.8.8	Tariff clock	77
<b>13.9</b>	<b>Inputs and Outputs</b>	<b>78</b>
13.9.1	Analogue output module	78
13.9.2	Alarm/digital output module (KD)	79
13.9.3	Pulse output module (KD)	80
13.9.4	Tariff input module	80
13.9.5	Digital input module	80
13.9.6	Watchdog output module (KD)	80
13.9.7	Analogue input module	80
13.9.8	Pulse input module	81
13.9.9	2 <sup>nd</sup> communications module (COM2) (KD)	81
<b>13.10</b>	<b>Alarms</b>	<b>81</b>
13.10.1	Alarm setting	81
13.10.2	Types of alarm	82
<b>13.11</b>	<b>Memory</b>	<b>83</b>
13.11.1	Memory division	83
13.11.2	Memory clearing	83
<b>13.12</b>	<b>Data Recorders</b>	<b>83</b>

13.12.1	Storage interval	84
13.12.2	MD time constant	84
13.12.3	Recorded quantities	84
<b>13.13</b>	<b>Power Quality Recorder Report</b>	<b>85</b>
13.13.1	Power supply quality	85
13.13.2	Frequency variations	86
13.13.3	Voltage variations	86
13.13.4	Dips and interruptions	86
13.13.5	Rapid voltage changes	86
13.13.6	Temporary overvoltages, flickers	86
13.13.7	Harmonics and THD	86
13.13.8	Resetting quality parameter reports	86
<b>13.14</b>	<b>Reset Operations</b>	<b>87</b>
13.14.1	Reset min/max values (KD)	87
13.14.2	Set energy counters (KD)	87
13.14.3	Reset energy counter costs (KD)	87
13.14.4	Reset maximal MD values (KD)	87
13.14.5	Reset the last MD period (KD)	87
13.14.6	MD synchronization (KD)	87
13.14.7	Reset alarm output (KD)	87
<b>14.</b>	<b>COMMUNICATIONS</b>	<b>88</b>
<b>14.1</b>	<b>Communications ports</b>	<b>88</b>
<b>14.2</b>	<b>QDSP Setting and Monitoring Software</b>	<b>88</b>
<b>14.3</b>	<b>MODBUS</b>	<b>88</b>
<b>14.4</b>	<b>DNP3</b>	<b>88</b>
<b>15.</b>	<b>SUPPORT POWER FOR REAL TIME CLOCK OPERATION</b>	<b>89</b>
<b>15.1</b>	<b>Battery Replacement</b>	<b>89</b>
15.1.1	Instructions for replacement	89
<b>15.2</b>	<b>Operation with the super capacitor</b>	<b>90</b>
<b>16.</b>	<b>TECHNICAL DATA</b>	<b>91</b>
<b>17.</b>	<b>WIRING DIAGRAMS AND CASE DIMENSIONS</b>	<b>96</b>
<b>18.</b>	<b>RELATED DOCUMENTS</b>	<b>100</b>



---

## 6. INTRODUCTION

### 6.1 General

The **M2x3** is a comprehensive measurement centre family aimed particularly at the medium voltage and industrial market segments throughout the world. It allows the user to select the most appropriate model from the family and customise the features to suit the particular on site conditions.

The **M2x3** measurement centre family integrates several measurements, monitoring, recording and metering functions in the same unit for comprehensive power system management. The use of numerical technology achieves high accuracy over a wide dynamic measuring family for instantaneous and integrated power system parameters. The **M2x3** offers:

- A cost-effective solution for Medium Voltage and Industrial markets
- Power Quality analysis and reporting to EN50160
- Modbus protocol for integrating into energy management and control systems.
- Setup and wrong connection wizards, demonstration screens and user customised display making the **M2x3** family user friendly.
- Tariff and cost management functions for use in secondary metering applications.
- High accuracy measurements
- Multi-lingual menu (English, German, French, Italian, Spanish, Russian etc)
- CE certification

The **M2x3** also provides a host of other measurement, monitoring, recording, and metering facilities as detailed below:

- Digital and analogue inputs and outputs
- High Measurement accuracy
- Power Quality Metering
- Tariff metering and cost management structure

The **M2x3** uses a software package called QDSP. It is suggested that the QDSP software is used, when possible, for programming the **M2x3** as it provides a simple interface for communicating with the product. A separate QDSP manual is available.

- QDSP is used for setting and monitoring all the iSTAT devices with communications, i400, i4Mx, and i500, M2x1, M2x2 and **M2x3**. It can also be used offline with the **M2x3** when used with a memory card. QDSP is also used to provide the interface to the data logging and Power Quality functionality required for **M243** and **M253**.
- QDSP also offers additional features such as upgrading from a secure web site for both the QDSP software and device firmware.

### KEY MESSAGES

- The iSTAT **M2x3** family is **easy to set and test**. In the substation world, more settings increase the chance of misapplication, and the potential for incorrect settings and inaccurate measurements. The iSTAT **M2x3** minimises the chance of an incorrect setting by using a setup wizard to help the operator configure the device.
- The iSTAT **M2x3** is an **economical** choice for measurements, with a family that allows the user to tailor the measurement centre and functions to the application.
- The iSTAT **M2x3** offers **easy fitting**, by using embedded current transformers and a wrong connection warning for the current circuits. It uses a standard 96mm DIN case.

- The **comprehensive** Energy Cost Management Library of functions enables the **M2x3** to energy readings from 4 registers, programme tariff structures and costs. This data can be recorded, communicated (MODBUS) or read via pulse outputs.
- **M2x3** allows connection to MODBUS based systems that are widely used by industrial and utility customers worldwide.
- All models in the **M2x3** family can use a memory card for configuring the meters and extracting data. This means that the “non–communicating” models can be configured offline prior to receipt by the user.

#### **ISTAT - THE standard** measurement platform

- Multiple advanced configuration features fitted as standard.
- Comprehensive choice of features for measurement applications - to satisfy all metering, measurement and data recording and power quality applications.
- Flexible programmable software (QDSP) allows the offline and online settings and data interpretation.
- Complete and informative documentation, QDSP also includes help information.
- A choice of different input and output options.

#### **Simple** to fit, **simple** to set, **simple** to connect

- Standard 96mm DIN
- Set up Wizard to aid configuration
- Wrong connection warning
- Demonstration displays
- User defined customised displays

#### **Advanced** technology

- High sampling rate of 128 samples per cycle
- A frequency family of 16 2/3Hz, 45/65Hz or 400Hz
- A memory card for data transfer
- Non-volatile Flash memory

#### **Economical**

- 5 models in the family tailored with a family of functions
- Universal Power for all site situations
- Common case size permits retrofitting without major re-engineering of the panel.
- 140 measurements available for all applications.

## **6.2 Family**

The **ISTAT M2x3** family provides:

- **M203** class 0.5 non-communicating Power meter. The **M203** is used to monitor and measure electrical parameters in a power system. It can be used in both single and three phase applications and provides voltage, current, frequency, phase angle and power information.
- **M213** class 0.5 non-communicating Power and class 1 Energy Meter. The **M213** adds energy measurement in all four quadrants and includes hardware options of tariff inputs and pulsed energy contact outputs.
- **M233** class 0.5 or 0.2 communicating Measurement Centre. The **M233** adds a tariff structure, alarm indication, class 1 or 0.5S energy measurement function and a range of communications options. This can be used for secondary metering applications.

- **M243** class 0.5 or 0.2 communicating Network Recorder with class 1 or 0.5S energy measurement. The **M243** adds up to 5 Data recorders so that up to 64 different electrical parameters can be monitored and 32 alarms recorded. This is used to monitor the status of plant or an electrical power system and log the required data.
- **M253** class 0.5 or 0.2 communicating Network Analyser with class 1 or 0.5S energy measurement. The **M253** adds Power Quality Compliance monitoring to EN50160.

Software:

- QDSP programming and analysis software

### 6.3 Measurements

The **M2x3** family is therefore ideally suited to applications where continuous monitoring of a single or three-phase system is required:

- **M203**: local indication for ac switchboard power measurements
- **M213**: local indication for ac switchboard power measurements, energy metering into a remote energy management system using pulsed outputs.
- **M233**: local and remote indication for ac switchboard power measurements, energy metering into a remote energy management system via communications.
- **M243**: System monitoring and alarm recording, local and remote indication for ac switchboard power measurements, energy metering into a remote energy management system,
- **M253**: Quality of supply compliance monitoring, system monitoring and alarm recording, local and remote indication for ac switchboard power measurements, energy metering into a remote energy management system.

TABLE 7-1 summarises the measurements available. The **M2x3** can be user configured for either single or three phase connection.

TABLE 7-1 : MEASUREMENTS	M203	M213	M233	M243	M253
V, I, P, Q, S, PF, PA, F, $\varphi$	●	●	●	●	●
Energy kWh class 1 or 0.5S		●	●	●	●
Maximum demand		●TF	●	●	●
Minimum values: V, I, P, Q, S, PF, PA, F, $\varphi$			●	●	●
Maximum values: V, I, P, Q, S, PF, PA, F, $\varphi$			●	●	●
THD (actual, min, max)			●	●	●
Harmonics (up to)			31 <sup>st</sup> or 63 <sup>rd</sup>	31 <sup>st</sup> or 63 <sup>rd</sup>	63 <sup>rd</sup>

NOTE: (TF) The **M213** has a thermal function only for maximum demand

### 6.4 Hardware Features

The **M2x3** family has several hardware features that are designed to make the installation, commissioning, and use of the meters as simple as possible, see TABLE 7-2.

It has a large 128 x 64 pixel Liquid Crystal Display (LCD) that can display information in several different font sizes and is backlit for use in conditions with a low light level. The menu is driven locally by a 5 key function pad on the front of the meter and the **M2x3** family can customise the display and key functions to enable to user to retrieve information as quickly as possible.

The **M2x3** has a LED alarm indicator that indicates the status for several functions depending on the model in the family; Steady RED for Memory Card activity; blinking GREEN for communications activity and blinking RED for an alarm condition.

The **M2x3** has an AC or Universal auxiliary supply and an auto ranging current and voltage measurement input so that it can be used in most site conditions without the need to specify this information at the order stage.

The **M2x3** (excluding **M203**, **M213**) has 4 energy counters and a real time clock so that it supports the comprehensive energy management applications.

The **M243** has 8MB of internal memory to support the data logging functions and the **M253** has 8MB of internal memory to support the data logging and Power Quality Recorder functions.

All the **M2x3** family supports a memory card with capacity up to 1GB which can be used to carry settings and extract records from the **M2x3** family. This means that all the **M2x3** family, including the non-communicating models, can have their settings made offline and downloaded via a memory card using the front card access port. The slot is protected by a cover to prevent humidity and dust ingress.

TABLE 7-2 : HARDWARE	M203	M213	M233	M243	M253
Large backlit LCD 128 x 64	●	●	●	●	●
LED alarm indication	●	●	●	●	●
5 key menu	●	●	●	●	●
Autorange V&I input	●	●	●	●	●
Power supply AC (A) or universal AC/DC (U)	A or U	A or U	A or U	A or U	A or U
Watchdog (optional)			●	●	●
4 Energy counters		●	●	●	●
Real time clock			●	●	●
Internal Flash Memory				8MB	8MB
Memory card	●	●	●	●	●

## 6.5 Communication and Inputs/Outputs

The **M2x3** family has a wide range of communications options that allow it to integrate with several different management systems, see TABLE 7-3.

The communicating meters (**M233**, **M243** and **M253**) have the option of an RS232/RS485 wired port, USB port or an RJ45 Ethernet port that supports MODBUS.

All the **M2x3** family has a front port supporting a memory card so that settings and records (**M243**, **M253** only) can be extracted locally from the meter. It can also be used to upgrade the firmware of the **M2x3**.

The **M2x3** (except for the **M203**) has two rear hardware modules, each of which can support 1 or 2 inputs or outputs as shown in table 7-3. Each module configuration is specified at the order stage, and they are independent from each other.

TABLE 7-3 : COMMUNICATIONS	M203	M213	M233	M243	M253
Memory card port	●	●	●	●	●
RS232/RS485, USB or Ethernet			●	●	●
Modbus RTU & TCP			●	●	●
Rear Hardware modules: 2 modules maximum, each having the option of:					
2x energy contacts		●	●	●	●
2x tariff inputs		●	●	●	●
2x alarm contacts			●	●	●
2x analogue outputs			●	●	●
1x Watchdog & 1x alarm contact			●	●	●
1x bistable alarm contact			●	●	●
2x digital inputs			●	●	●

TABLE 7-3 : COMMUNICATIONS	M203	M213	M233	M243	M253
2x analogue input			●	●	●
2x pulse input			●	●	●
1x RS485 port (COM2)			●	●	●
1x RS232 port (COM2)			●	●	●

## 6.6 User Features

The **M2x3** family has a wide range of user features that are designed to make the installation and commissioning simple. These features are summarised in TABLE 7-4 below.

The Setup Wizard takes the user through the basic settings required to commission the **M2x3**. The benefit of the wizard is that it leads the commissioning engineer through all the basic settings required to install the **M2x3** ensuring that the **M2x3** is correctly setup. This is fully detailed in section 12.1.

The **M2x3** will monitor the voltage and current polarity and when it detects that an input has been incorrectly connected it will display a warning symbol on the display. This is useful when direction is important, such as in energy applications, to ensure that the values calculated are correct.

The **M2x3** provides over 140 different measurements that the operator can scroll through and read on the display. If the operator only wants to see a small number of measurements, they can configure the display to show up to 3 customised screens. The refresh time is programmable to enable the operator time to interpret the information on the display.

To demonstrate the different display options that are available, the **M2x3** has a demo option which will display each of the different screens available. The refresh time is programmable so that the operator is given time to interpret the information shown.

TABLE 7-4 : USER FEATURES	M203	M213	M233	M243	M253
Set up Wizard	●	●	●	●	●
Wrong connection warning	●	●	●	●	●
3 Custom screens	●	●	●	●	●
Reset default settings	●	●	●	●	●
Demonstration screens	●	●	●	●	●
Settable refresh times	●	●	●	●	●

## 6.7 Applications

The **M2x3** family can be used in a wide range of different applications depending on the model, the applications are summarised in TABLE 7-5 below.

TABLE 7-5 : APPLICATION	M203	M213	M233	M243	M253
Power measurements	●	●	●	●	●
Energy Metering		●	●	●	●
Cost Management			●	●	●
Programmable alarms			●	●	●
Measurement recorder				●	●
Quality of supply					●
QDSP setting software	● (Memory card only)	● (Memory card only)	●	●	●

**Power Measurements:** All the **M2x3** family provide a wide range of instantaneous analogue values; Voltage, current, Power, phase angle, power factor and frequency. These are available locally on all the **M2x3** family and remotely on selected models. The **M2x3** therefore replaces several separate instruments and is ideally suited to ac switchboard applications.

**Energy and sub Metering:** With addition of 4 quadrant energy measurement, the **M2x3** can be used in sub metering applications where information is passed to an energy management system to monitor the performance of the ac power system. Depending on the **M2x3** model and options selected, the **M2x3** can use a combination of pulsed energy contacts, analogue tariff inputs and communications to integrate with and provide this data to the control system.

In addition, measurements such as maximum and minimum values and maximum demand information provide valuable information on the operation of plant and system monitoring to ensure that it is performing correctly.

**Cost Management:** The addition of a real time clock and a tariff structure means that the **M2x3** can be used in stand-alone tariff or revenue sub metering applications. This allows the energy consumed to be given a financial cost that can vary depending on the time of day and season of the year. This provides information on the cost of plant operation and can be used to ensure that equipment and processes are used in the most financially efficient manner.

**Measurement Recorder:** The **M243** and **M253** have up to 4 independent data recorders that provide trending information on up to 64 different analogue values. The type of value can be defined for each parameter, i.e. minimum, maximum, or average. Maximum demand and maximum and minimum instantaneous (every cycle) values can also be recorded. The status of all the 32 software alarms can also be recorded within a separate alarm recorder. This provides a comprehensive record of the status of the monitoring system and a timed record of events.

**Quality of supply:** The **M253** provides a quality of supply monitor that complies with the European standard EN50160. This power quality standard is used to monitor electrical systems and ensure that it falls within several different limits ensuring that the user has a consistent and correct supply of electricity. The EN50160 standard monitors the following electrical characteristics:

- Frequency and voltage variations
- Voltage unbalances, interruptions, and dips
- Flicker
- Harmonics and THD

## 7. SYSTEM MODES

### 7.1 Connection Mode

The connection mode of the **M2x3** is menu configurable. The following options are available:

- 1b - single phase connection,
- 3b - three-phase, three-wire connection with balanced load,
- 4b - three-phase, four-wire connection with balanced load,
- 3u - three-phase, three-wire connection with unbalanced load
- 4u - three-phase, four-wire connection with unbalanced load.

#### 7.1.1 Valid measurements

The following tables list the valid measurements for each connection type.

Key: ● - measured, ○ - calculated, × - not supported

TABLE 8-1 : BASIC MEASUREMENTS		Parameter	Unit	Connection				
				1b	3b	3u	4b	4u
Phase	Voltage $U_1$	U1	V	●	×	×	●	●
	Voltage $U_2$	U2	V	×	×	×	○	●
	Voltage $U_3$	U3	V	×	×	×	○	●
	Average voltage $U^-$	$U_{\lambda}$	V	×	×	●	○	●
	Current $I_1$	I1	A	●	●	●	●	●
	Current $I_2$	I2	A	×	○	●	○	●
	Current $I_3$	I3	A	×	○	●	○	●
	Current $I_n$	$I_n$	A	×	○	●	○	●
	Total current $I_t$	I	A	●	○	○	○	●
	Average current $I_a$	$I_{avg}$	A	×	○	○	○	●
	Active power $P_1$	P1	W	●	×	×	●	●
	Active power $P_2$	P2	W	×	×	×	○	●
	Active power $P_3$	P3	W	×	×	×	○	●
	Total active power $P_t$	P	W	●	●	●	○	●
	Reactive power $Q_1$	Q1	var	●	×	×	●	●
	Reactive power $Q_2$	Q2	var	×	×	×	○	●
Reactive power $Q_3$	Q3	var	×	×	×	○	●	
Total reactive power $Q_t$	Q	var	●	●	●	○	●	

TABLE 8-2 : BASIC MEASUREMENTS		Parameter	Unit	Connection Type				
				1b	3b	3u	4b	4u
Phase	Apparent power $S_1$	S1	VA	●	×	×	●	●
	Apparent power $S_2$	S2	VA	×	×	×	○	●
	Apparent power $S_3$	S3	VA	×	×	×	○	●
	Total apparent power $S_t$	S	VA	●	●	●	○	●
	Power factor $PF_1$	PF1/ePF1		●	×	×	●	●

	TABLE 8-3 : BASIC MEASUREMENTS	Parameter	Unit	Connection Type				
				1b	3b	3u	4b	4u
Phase	Power factor PF2	PF2/ePF2		x	x	x	○	●
	Power factor PF <sub>3</sub>	PF3/ePF3		x	x	x	○	●
	Total power factor PF <sup>~</sup>	PF/ePF		●	●	●	○	●
	Power angle φ <sub>1</sub>	φ <sub>1</sub>	°	●	x	x	●	●
	Power angle φ <sub>2</sub>	φ <sub>2</sub>	°	x	x	x	○	●
	Power angle φ <sub>3</sub>	φ <sub>3</sub>	°	x	x	x	○	●
	Total power angle φ <sup>~</sup>	φ	°	●	●	●	○	●
	THD of phase voltage U <sub>f1</sub>	U1%	%THD	●	x	x	●	●
	THD of phase voltage U <sub>f2</sub>	U2%	%THD	x	x	x	○	●
	THD of phase voltage U <sub>f3</sub>	U3%	%THD	x	x	x	○	●
	THD of phase current I <sub>1</sub>	I1%	%THD	●	●	●	●	●
	THD of phase current I <sub>2</sub>	I2%	%THD	x	○	●	○	●
	THD of phase current I <sub>3</sub>	I3%	%THD	x	○	●	○	●
Phase-to-phase	Phase-to-phase voltage U <sub>12</sub>	U12	V	x	●	●	○	●
	Phase-to-phase voltage U <sub>23</sub>	U23	V	x	●	●	○	●
	Phase-to-phase voltage U <sub>31</sub>	U31	V	x	●	●	○	●
	Average phase-to-phase voltage (U <sub>f</sub> )	U <sub>Δ</sub>	V	x	x	x	○	●
	Phase-to-phase angle φ <sub>12</sub>	φ <sub>12</sub>	°	x	x	x	○	●
	Phase-to-phase angle φ <sub>23</sub>	φ <sub>23</sub>	°	x	x	x	○	●
	Phase-to-phase angle φ <sub>31</sub>	φ <sub>31</sub>	°	x	x	x	○	●
	Voltage unbalance U <sub>u</sub>	U <sub>u</sub>	%	x	●	●	x	●
	THD of phase-to-phase voltage THD <sub>U12</sub>	U12%	%THD	x	●	●	○	●
	THD of phase-to-phase voltage THD <sub>U23</sub>	U23%	%THD	x	●	●	○	●
THD of phase-to-phase voltage THD <sub>U31</sub>	U31%	%THD	x	●	●	○	●	
Energy	Counters 1-4	E1, E2, E3, E4	Wh Vah varh	●	●	●	●	●
	Active tariff	Atar		●	●	●	●	●
	Cost by meters	E1\$, E2\$, E3\$, E4\$	XXXX	●	●	●	●	●
	Total cost			●	●	●	●	●
Max. values MD	MD current I <sub>1</sub>	I1	A	x	○	●	○	●
	MD current I <sub>2</sub>	I2	A	x	○	●	○	●
	MD current I <sub>3</sub>	I3	A	●	●	●	●	●
	MD active power P (positive)	P+	W	●	●	●	●	●
	MD active power P (negative)	P-	W	●	●	●	●	●
	MD reactive power Q-L	Q <sub>≡</sub>	var	●	●	●	●	●

	TABLE 8-4 : BASIC MEASUREMENTS	Parameter	Unit	Connection Type				
				1b	3b	3u	4b	4u
	MD reactive power Q-C	$Q \frac{1}{3}$	var	●	●	●	●	●
	MD apparent power S	S	VA	●	●	●	●	●

	TABLE 8-5 : MIN/MAX MEASUREMENTS	Connection Type				
		1b	3b	3u	4b	4u
Instantaneous/Maximal/Minimal values	Voltage U <sub>1</sub>	●	x	x	●	●
	Voltage U <sub>2</sub>	x	x	x	○	●
	Voltage U <sub>3</sub>	x	x	x	○	●
	Phase-to-phase voltage U <sub>12</sub>	x	●	●	○	●
	Phase-to-phase voltage U <sub>23</sub>	x	○	●	○	●
	Phase-to-phase voltage U <sub>31</sub>	x	○	●	○	●
	Phase current I <sub>1</sub>	●	●	●	●	●
	Phase current I <sub>2</sub>	x	○	●	○	●
	Phase current I <sub>3</sub>	x	○	●	○	●
	Active power P <sub>1</sub>	●	x	x	●	●
	Active power P <sub>2</sub>	x	x	x	○	●
	Active power P <sub>3</sub>	x	x	x	○	●
	Common active power P	x	●	●	○	●
	Apparent power S <sub>1</sub>	●	x	x	●	●
	Apparent power S <sub>2</sub>	x	x	x	○	●
	Apparent power S <sub>3</sub>	x	x	x	○	●
	Common apparent power S	x	●	●	○	●
	Frequency f	●	●	●	●	●
Internal temperature	●	●	●	●	●	

Key ● - measured, ○ - calculated, x - not supported

	TABLE 8-6 : HARMONIC MEASUREMENTS	Connection type				
		1b	3b	3u	4b	4u
Harmonics up to 31/63	Phase voltage U <sub>1</sub>	●	x	x	●	●
	Phase voltage U <sub>2</sub>	x	x	x	○	●
	Phase voltage U <sub>3</sub>	x	x	x	○	●
	Phase-to-phase voltage U <sub>12</sub>	x	●	●	○	●
	Phase-to-phase voltage U <sub>23</sub>	x	●	●	○	●
	Phase-to-phase voltage U <sub>31</sub>	x	●	●	○	●
	Phase current I <sub>1</sub>	●	●	●	●	●
	Phase current I <sub>2</sub>	x	○	●	○	●
	Phase current I <sub>3</sub>	x	○	●	○	●

Key: ● - measured, ○ - calculated, x - not supported

TABLE 8-7 : GRAPHICAL DISPLAY		Connection type				
		1b	3b	3u	4b	4u
Time/FT	Phase voltage U <sub>1</sub>	●	x	x	●	●
	Phase voltage U <sub>2</sub>	x	x	x	○	●
	Phase voltage U <sub>3</sub>	x	x	x	○	●
	Phase-to-phase voltage U <sub>12</sub>	x	●	●	○	●
	Phase-to-phase voltage U <sub>23</sub>	x	●	●	○	●
	Phase-to-phase voltage U <sub>31</sub>	x	●	●	○	●
	Phase current I <sub>1</sub>	●	●	●	●	●
	Phase current I <sub>2</sub>	x	○	●	○	●
	Phase current I <sub>3</sub>	x	○	●	○	●

Key: ● - measured, ○ - calculated, x - not supported

TABLE 8-8 : POWER QUALITY		Connection Type				
		1b	3b	3u	4b	4u
Quality parameters	Frequency variations 1/2	●	●	●	●	●
	Voltage variations 1/2	●	●	●	●	●
	Voltage unbalances	●	x	x	●	●
	Voltage dips	x	x	x	○	●
	Voltage interruptions	x	x	x	○	●
	Long interruptions	x	●	●	○	●
	Transients	x	●	●	○	●
	Flickers Pst / Plt	x	●	●	○	●
	Temporary overvoltages	●	●	●	●	●
	THD's	x	○	●	○	●
	Harmonics	x	○	●	○	●

Key: ● - measured, ○ - calculated, x - not supported

NOTE: For 3b and 3u connection mode, only phase-to-phase voltages are measured. Because of that, factor  $\sqrt{3}$  is applied to calculation of quality considering nominal phase voltage.  
For 4u connection mode measurements support is same as for 1b.

## 7.2 Power Mode

The power mode is used for the signing of power measurements. The user cannot set the **M2x3** power mode. It is defined as follows:

- When displaying active power, a positive sign indicates export power (a consumer) whilst a negative sign indicates import power (a generator).
- When displaying reactive power, a coil symbol indicates an inductive load (a consumer) whilst a capacitor symbol indicates a capacitive load (a generator).

## 7.3 Operating Energy Quadrants

The operating energy quadrants are used to determine which types of energy are added to the energy counters. The user may modify the operating energy quadrants via the remote communications interface or by using the front menu and buttons.

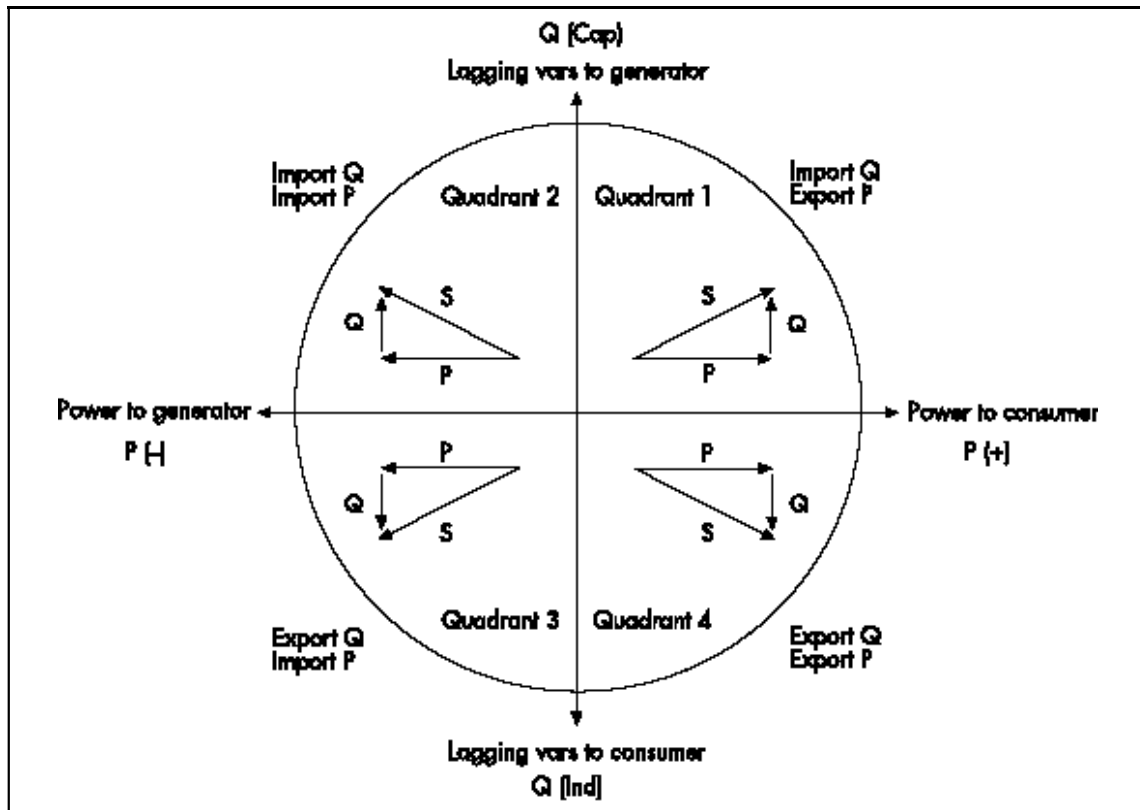

FIGURE 8-1 : POWER FLOW

## 8. INSTRUMENTATION

### 8.1 Measurements

With the increase in harmonics present in today's power systems, due to the increased use of electronic loads such as computers, variable frequency drives, etc. it is important, when accurate monitoring of electrical parameters is required, to use a measuring technique that allows for their presence. Conventional measurement methods, that use a mean sensing technique, respond to the mean or average of the input waveform. This is only accurate when the input waveform approaches a pure sinusoid.

The **M2x3** uses a true RMS (root-mean-square) measurement technique that provides accurate measurement with harmonics present up to the 63<sup>rd</sup>. The **M2x3** reads 128 samples per cycle and the true RMS measurement is obtained using these sampled values.

Individual harmonics up to 31<sup>st</sup> (or 63<sup>rd</sup>) on the **M233/M243** and 63<sup>rd</sup> on the **M253** can be displayed using the QDSP Software and downloaded on the communications.

The **M2x3** display can display the measured values in a number of pre-set display views, or the user can customise the display. An example is shown in figure 9.1 below.

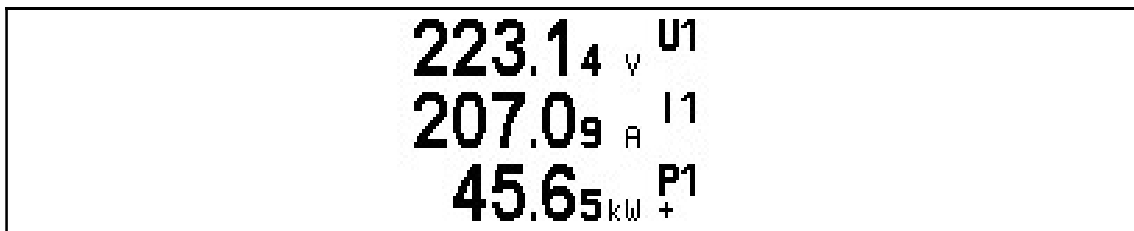

FIGURE 9-1 : PRESET DISPLAY SHOWING VOLTAGE, CURRENT AND POWER IN PHASE 1

### 8.2 Glossary

The following terms and symbols are used:

TABLE 9-1 : SYMBOLS	
MD	Sample factor
M <sub>P</sub>	Averaging interval
U <sub>f</sub>	Phase voltage (U <sub>1</sub> , U <sub>2</sub> or U <sub>3</sub> )
U <sub>ff</sub>	Phase-to-phase voltage (U <sub>12</sub> , U <sub>23</sub> or U <sub>31</sub> )
N	Total number of samples in a period
n	Sample number (0 ≤ n ≤ N)
x, y	Phase number (1, 2 or 3)
i <sub>n</sub>	Current sample n
u <sub>fn</sub>	Phase voltage sample n
u <sub>ffn</sub>	Phase-to-phase voltage sample n
φ <sub>f</sub>	Power angle between current and phase voltage f (φ <sub>1</sub> , φ <sub>2</sub> or φ <sub>3</sub> )
U <sub>u</sub>	Voltage unbalance
U <sub>c</sub>	Agreed supply voltage

TABLE 9-2 : GLOSSARY	
Term	Explanation
RMS	Root Mean Square value
Flash	Type of a memory module that keeps its content in case of power supply failure
Ethernet	IEEE 802.3 data layer protocol
MODBUS/DNP3	Industrial protocol for data transmission
Memory Card	Multi-Media Card (MMC) or SD Card
QDSP	Software for iSTAT family
AC	Alternating voltage
PA	Power angle (angle between current and voltage)
PF	Power factor
THD	Total harmonic distortion
MD	Measurement of average values in time interval
Harmonic voltage - harmonic	Sine voltage with frequency equal to integer multiple of basic frequency
Hand-over place	Connection spot of consumer installation in public network
Flicker	Voltage fluctuation causes changes of luminous intensity of lamps, which causes the so-called flicker affect
RTC	Real Time Clock
Sample factor	Defines several periods for measuring calculation based on measured frequency
Averaging interval	Defines frequency of refreshing displayed measurements based on a Sample factor

### 8.3 Supported Measurements

The measurements that the **M2x3** family supports will depend on the model selected and whether the measurements are available on the display or over the communications. The following tables show which measurements are available on each **M2x3** model.

TABLE 9-3 : MEASUREMENTS		M203	M213	M233	M243	M253
Phase	Voltage $U_1, U_2, U_3$ in $U^-$	●	●	●	●	●
	Current $I_1, I_2, I_3, I_n, I_t$ in $I_a$	●	●	●	●	●
	Active power $P_1, P_2, P_3,$ and $P_t$	●	●	●	●	●
	Reactive power $Q_1, Q_2, Q_3,$ and $Q_t$	●	●	●	●	●
	Apparent power $S_1, S_2, S_3,$ and $S_t$	●	●	●	●	●
	Power factor $PF_1, PF_2, PF_3$ and $PF^-$	●	●	●	●	●
	Power angle $\varphi_1, \varphi_2, \varphi_3$ and $\varphi^-$	●	●	●	●	●
	THD of phase voltage $U_{r1}, U_{r2}$ and $U_{r3}$	×	×	●	●	●
	THD of power angle $I_1, I_2$ and $I_3$	×	×	●	●	●

TABLE 9-4 : MEASUREMENTS		M203	M213	M233	M243	M253
Phase-to-phase	Phase-to-phase voltage $U_{12}, U_{23}, U_{31}$	●	●	●	●	●
	Average phase-to-phase voltage $U_{ff}$	●	●	●	●	●
	Phase-to-phase angle $\varphi_{12}, \varphi_{23}, \varphi_{31}$	●	●	●	●	●
	Voltage unbalance $U_u$	x	x	●	●	●
	THD of phase-to-phase voltage	x	x	●	●	●
Energy	Counter 1	x	●	●	●	●
	Counter 2	x	●	●	●	●
	Counter 3	x	●	●	●	●
	Counter 4	x	●	●	●	●
	Total	x	●	●	●	●
	Active tariff	x	●	●	●	●
	Cost by counters	x	x	●	●	●
	Total cost	x	x	●	●	●
Maximal values MD	Phase current $I_1$	x	○	●	●	●
	Phase current $I_2$	x	○	●	●	●
	Phase current $I_3$	x	○	●	●	●
	Active power P (Positive)	x	○	●	●	●
	Active power P (Negative)	x	○	●	●	●
	Reactive power Q - L	x	○	●	●	●
	Reactive power Q - C	x	○	●	●	●
	Apparent power S	x	○	●	●	●

● - measured, x - not supported

TABLE 9-5 : MEASUREMENTS		M203	M213	M233	M243	M253
Min./max. measurements	Voltage $U_1$	x	x	●	●	●
	Voltage $U_2$	x	x	●	●	●
	Voltage $U_3$	x	x	●	●	●
	Phase-to-phase voltage $U_{12}$	x	x	●	●	●
	Phase-to-phase voltage $U_{23}$	x	x	●	●	●
	Phase-to-phase voltage $U_{31}$	x	x	●	●	●
	Phase current $I_1$	x	x	●	●	●
	Phase current $I_2$	x	x	●	●	●
	Phase current $I_3$	x	x	●	●	●
	Active power $P_1$	x	x	●	●	●
	Active power $P_2$	x	x	●	●	●
	Active power $P_3$	x	x	●	●	●
	Common active power P	x	x	●	●	●
	Apparent power $S_1$	x	x	●	●	●
	Apparent power $S_2$	x	x	●	●	●
Apparent power $S_3$	x	x	●	●	●	

TABLE 9-5 : MEASUREMENTS		M203	M213	M233	M243	M253
	Common apparent power S	x	x	●	●	●
	Frequency f	x	x	●	●	●
	Internal temperature	x	x	●	●	●
Other functions	Frequency	●	●	●	●	●
	Internal temperature	●	●	●	●	●
	RTC date	x	x	●	●	●
	RTC	x	x	●	●	●
	Time graphs (I <sub>1</sub> , I <sub>2</sub> , I <sub>3</sub> , U <sub>1</sub> , U <sub>2</sub> , U <sub>3</sub> , U <sub>12</sub> , U <sub>23</sub> and U <sub>31</sub> )	x	x	●	●	●
	FFT graphs (I <sub>1</sub> , I <sub>2</sub> , I <sub>3</sub> , U <sub>1</sub> , U <sub>2</sub> , U <sub>3</sub> , U <sub>12</sub> , U <sub>23</sub> and U <sub>31</sub> )	x	x	x	x	●
	Phase voltage harmonics	x	x	To 31 <sup>st</sup> or 63 <sup>rd</sup>	To 31 <sup>st</sup> or 63 <sup>rd</sup>	To 63 <sup>rd</sup>
	Phase-to-phase voltage harmonics	x	x	To 31 <sup>st</sup> or 63 <sup>rd</sup>	To 31 <sup>st</sup> or 63 <sup>rd</sup>	To 63 <sup>rd</sup>
	Current harmonics	x	x	To 31 <sup>st</sup> or 63 <sup>rd</sup>	To 31 <sup>st</sup> or 63 <sup>rd</sup>	To 63 <sup>rd</sup>
	Analysis in compliance with EN 50160	x	x	x	x	●

● - thermal function, ○ - measured, x - not supported

8.3.1 Voltage

All versions of the **M2x3** except for the 3-phase 3-wire versions, measure the true RMS value of the phase voltages (U<sub>a</sub>, U<sub>b</sub>, U<sub>c</sub>) connected to the unit. The three line voltages (U<sub>ab</sub>, U<sub>bc</sub>, U<sub>ca</sub>), average phase voltage (U) and average line voltage (U<sub>Δ</sub>) are calculated from these measured parameters. For 3-phase 3-wire balanced systems, the **M2x3** creates a virtual neutral internally.

The 3-phase 3-wire versions of the **M2x3** measure the true RMS value of the phase to phase voltage.

$U_f = \sqrt{\frac{\sum_{n=1}^N u_n^2}{N}}$	$U_{xy} = \sqrt{\frac{\sum_{n=1}^N (u_{xn} - u_{yn})^2}{N}}$
<p><b>V rms Phase calculation</b>                      N = 128 samples in one period (up to 65Hz)                      N = 128 samples in M periods (above 65Hz),                      eg at 400Hz, n=7</p>	<p><b>V rms Phase to Phase calculation</b>                      N = samples in one period                      U<sub>x</sub>, U<sub>y</sub> = phase voltages U<sub>f</sub></p>

The available phase, line and average voltages (instantaneous, minimum and maximum values) can be viewed on the **M2x3** display or via the remote communications link.

The voltage unbalance is measured as:

$$U_u = \sqrt{\frac{1 - \sqrt{3 - 6\beta}}{1 + \sqrt{3 - 6\beta}}} \cdot 100\%$$

$$\beta = \frac{U_{12fund}^4 + U_{23fund}^4 + U_{31fund}^4}{(U_{12fund}^4 + U_{23fund}^4 + U_{31fund}^4)^2}$$

**Voltage unbalance**  
Ufund = first harmonic of the phase to phase voltage

### 8.3.2 Current

The **M2x3** measures the true RMS value of the phase currents ( $I_a$ ,  $I_b$ ,  $I_c$ ) connected to the unit. The neutral current ( $I_n$ ), the average of all phase currents and the sum of all phase currents ( $I_t$ ) are calculated from the three phase currents.

The available phase currents, average current and neutral current (instantaneous, minimum, and maximum values) can be viewed on the **M2x3** display or via the remote communications link whilst the sum of all phase currents is only available via the remote communications link.

$I_{RMS} = \sqrt{\frac{\sum_{n=1}^N i_n^2}{N}}$	$I_n = \sqrt{\frac{\sum_{n=1}^N (i_{1n} + i_{2n} + i_{3n})^2}{N}}$
<p><b>I rms calculation</b></p> <p>N = 128 samples in one period (up to 65Hz)</p> <p>N = 128 samples in M periods (above 65Hz), e.g. at 400Hz, n=7</p>	<p><b>RMS Neutral calculation</b></p> <p>i-n samples in phase current 1, 2 or 3</p> <p>N = 128 samples in a period (up to 65Hz)</p>

### 8.3.3 Angles between phases

Angles between phases indicate the angles between the vectors of phase voltages. A positive mark indicates correct phase sequence, while a negative mark indicates an opposite phase sequence of the measured system.

The Phase Angles can be viewed on the **M2x3** display or via the remote communications link.

### 8.3.4 Frequency

The system frequency is calculated from the time of the measured voltage and can be viewed from both the **M2x3** display (also the frequency with instantaneous 10 second average) and the remote communications link.

### 8.3.5 Harmonics

The percentage total harmonic distortion (%THD) value is the ratio of the sum of the powers of the harmonic frequencies above the fundamental frequency to the power of the fundamental frequency. This sum of the powers is a geometric total, formed by taking the square root of the sum of the squares of the amplitude of each of the harmonics.

The **M2x3** provides %THD values for each phase current, each phase voltage, and for the line voltages (instantaneous, minimum, and maximum values).

$I_f \text{THD}(\%) = \frac{\sqrt{\sum_{n=2}^{63} I_n^2}}{I_1} \cdot 100$	
<b>Current THD calculation</b> $I_1$ = value of first harmonic $N$ = number of harmonic	<b>M2x3 display</b>

$U_f \text{THD}(\%) = \frac{\sqrt{\sum_{n=2}^{63} U_n^2}}{U_1} \cdot 100$	
<b>Phase Voltage THD calculation</b> $U_1$ = value of first harmonic $N$ = number of harmonic	<b>M2x3 display</b>

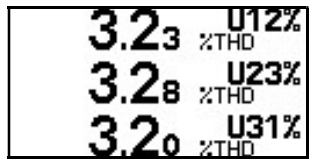
$U_{ff} \text{THD}(\%) = \frac{\sqrt{\sum_{n=2}^{63} U_n^2}}{U_1} \cdot 100$	
<b>Line to Line Voltage THD calculation</b> $U_1$ = value of first harmonic $N$ = number of harmonic	<b>M2x3 display</b>

The **M233** and **M243** can display harmonics up to the 31<sup>st</sup> (or 63<sup>rd</sup>) on the display and via QDSP; the values are also available via the communications.

The **M253** Power Quality Analyser that can record up to the 63<sup>rd</sup> Harmonic values as part of the EN50160 Compliance monitoring. The harmonic values can be shown on the display, via QDSP and via the communications.

## 8.4 Power, Power Factor and Energy

### 8.4.1 Power

The **M2X3** provides accurate measurement of active ( $P_a$ ,  $P_b$ ,  $P_c$ ,  $P_t$ ), reactive ( $Q_a$ ,  $Q_b$ ,  $Q_c$ ,  $Q_t$ ) and apparent power ( $S_a$ ,  $S_b$ ,  $S_c$ ,  $S_t$ ). For a four-wire system the powers are calculated both for each phase separately and as a total. For a three-wire system only total power values are measured.

- Total active power ( $P_t$ )

$P_f = \frac{1}{N} \cdot \sum_{n=1}^N (u_f N_n \times i_f N_n)$
<b>Active Power</b> $N$ = number of periods $n$ = several samples in a period $f$ = phase designation

$$P_t = P_1 + P_2 + P_3$$

**Total Active Power**

t = total power

1,2,3 phase designation

- Total reactive power ( $Q_t$ )
  - Reactive Power by Phases (Standard)

$$Q_f = \text{Sign}Q_f(\phi) \times \sqrt{S_f^2 - P_f^2}$$

**Reactive Power** $S_f$  = apparent power by phase $P_f$  = active power by phase

- Reactive Power by Phases (Delayed current method)

$$Q_f = \frac{1}{N} \cdot \sum_{n=1}^N (u_{f_n} \times i_{f_{[n+N/4]}})$$

**Reactive Power**

N - several samples in a period

N - sample number ( $0 \leq n \leq N$ )

f - phase designation

$$Q_t = Q_1 + Q_2 + Q_3$$

**Total Reactive Power** $Q_f$  = reactive power by phase

- Total apparent power ( $S_t$ )

$$S_f = U_f \times I_f$$

**Apparent Power** $U_f$  = phase voltage $I_f$  = phase current

$$S_t = S_1 + S_2 + S_3$$

**Total Apparent Power** $S_f$  = apparent power by phase

- Power direction

When displaying active power, a positive sign indicates export power (a consumer) whilst a negative sign indicates import power (a generator).

When displaying reactive power, a coil symbol indicates an inductive load (a consumer) whilst a capacitor symbol indicates a capacitive load (a generator).

All the available power parameters can be viewed using either the M2x3 display or via the remote communications link.

$\text{Sign}Q_f(\varphi)$ $\varphi \in [0^\circ - 180^\circ] \Rightarrow \text{Sign}Q_f(\varphi) = +1$ $\varphi \in [180^\circ - 360^\circ] \Rightarrow \text{Sign}Q_f(\varphi) = -1$
<p><b>Reactive Power direction</b></p> <p><math>Q_f</math> - reactive power (by phases)</p> <p><math>\varphi</math> - power angle</p>

$\varphi_s = a \tan 2(P_t, Q_t)$ $\varphi_s = [-180^\circ, 179,99^\circ]$
<p><b>Total Power angle</b></p>

#### 8.4.2 Power factor

The power factor is calculated as a quotient of active and apparent power for each phase separately ( $\cos\varphi_a$ ,  $\cos\varphi_b$ ,  $\cos\varphi_c$ ) and as a total ( $\cos\varphi_t$ ). A positive sign and a coil symbol denote an inductive load (a consumer) whilst a negative sign and a capacitor symbol defines a capacitive load (a generator).

$\text{PF} = \frac{P}{S}$
<p><b>Power Factor</b></p>

All available power factor parameters can be read from the **M2x3** display or via the remote communications link.

#### 8.4.3 Energy

Four counters are available so that energy in each of the four quadrants can be measured. The configuration of the four counters can be adapted to the customer's needs via the front menu or via the remote communications link.

All four energy measurements may be viewed using either the **M2x3** display or a remote communications link.

- Energy Tariff Price

The tariff calculation used in the Cost Management function is derived as follows:

$\text{Price in tariff} = \text{Price} \cdot 10^{\text{Tariff price exponent}}$
<p>Energy Tariff Price</p>

#### 8.4.4 Demand measurements

The **M2x3** (except for the **M203**) provides maximum demand values from a variety of average demand values (fixed window, sliding window and thermal) for the following electrical parameters:

TABLE 9-6 : DEMAND VALUES	M203	M213	M233	M243	M253
Max Demand		● TF	●	●	●
Tariff Clock			●	●	●
Cost Management			●	●	●

NOTE: TF = thermal function

#### 8.4.5 Real time clock (energy clock)

The **M233**, **M243** and **M253** are provided with a built-in real time clock. It is intended for registration of time of the occurrence of Maximum demands, and for synchronisation of the time interval. The clock is also used by the Cost Management feature when allocating different cost or tariff structures throughout the day and for periodic (seasonal) times throughout the year.

#### 8.4.6 Maximum demands (MDs)

The **M2x3** (except for the **M203**) stores the maximum demand value since last reset and its corresponding time stamp. The unit also displays the present or 'dynamic' maximum demand.

#### 8.4.7 Average demands

##### 8.4.7.1 Fixed window

The fixed interval method calculates an average demand value over a fixed time. The period can be set over the family 1 to 255 minutes. This is available in the **M233**, **M243** and **M253** as a selectable function.

»TIME IN A PERIOD« will actively show the remaining time until the end of the period, until a current MD and maximal MD from the last reset are calculated. When displays for Pt(+/-), Qt(L/C), St, I1, I2 and I3 are updated, a new period and measurement of new average values are started. »TIME IN A PERIOD« then shows 0 of X min.

A new period also starts after a longer interruption of power supply (more than 1 s). If time constant is set to one of the values of 2, 3, 4, 5, 6, 10, 12, 15, 20, 30 or 60 minutes, »TIME IN A PERIOD« is set to such value that one of the following intervals will be terminated at a full hour. In other cases of time constants, »TIME IN A PERIOD« is set to 0.

Example:

Mode: Fixed window  
 Time constant: 8 min.  
 Current MD and maximal MD: Reset at 0 min.

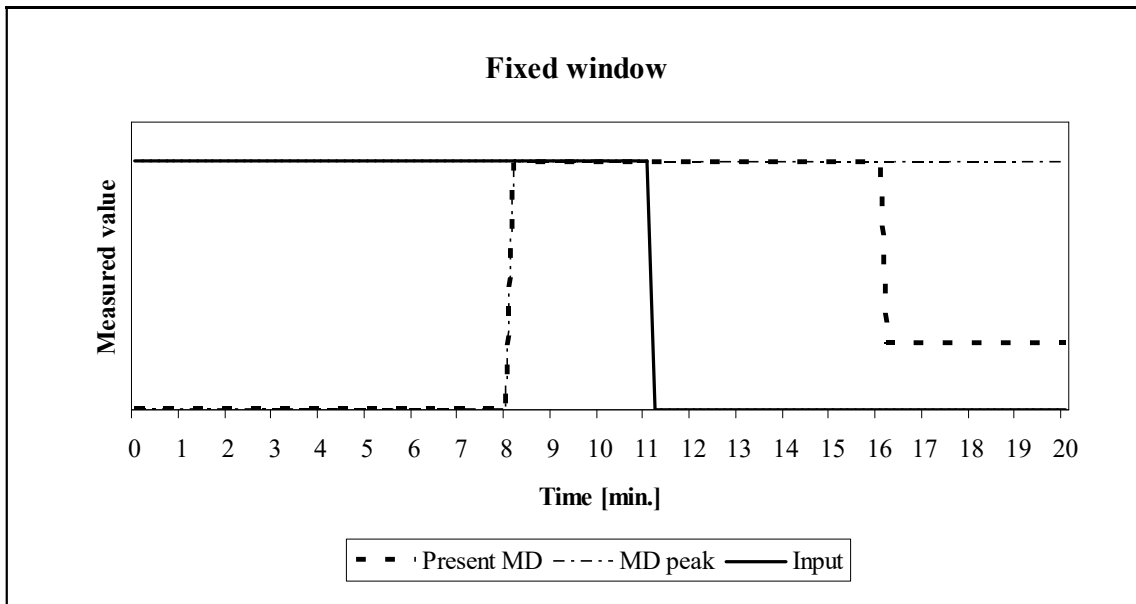

#### 8.4.7.2 Sliding window

The sliding window technique allows the user to divide the time into several sub-periods. The average demand value over the demand period is displayed, however, after the initial demand period has elapsed, the demand value will be updated by the addition of a further sub-period, thus creating a 'sliding window' measurement.

For example, if the total period is 30 minutes (consisting of 5 sub-periods of 6 minutes duration), after the first 5 sub-periods have elapsed a new window will be added and the oldest window will be deleted, thus creating a sliding window.

A new period also starts after a longer interruption of power supply (more than 1 s). If time constant is set to one of the values of 2, 3, 4, 5, 6, 10, 12, 15, 20, 30 or 60 minutes, »TIME IN A PERIOD« is set to such value that one of the following intervals will be terminated at a full hour. In other cases of time constants, »TIME IN A PERIOD« is set to 0.

The number of sub-periods may be set between 2 to 15, with each period set between 1 to 255 minutes.

This is available in the **M233**, **M243** and **M253** as a selectable function.

Example:

Mode: Sliding windows  
 Time constant: 2 min.  
 No. of sub-periods: 4  
 Current MD and maximal MD: Reset at 0 min.

A complete period lasts for 8 minutes and consists of 4 sub-periods that are 2 minutes long. A current MD and a maximal MD are reset at 0 min. "TIME IN A PERIOD" is data for a sub-period so that the values for a current MD and a maximal MD are regenerated every two minutes. After 4 sub-periods (1 complete period) the oldest sub-period is eliminated when a new one is added, so that average (a window) always covers the last 4 sub-periods.

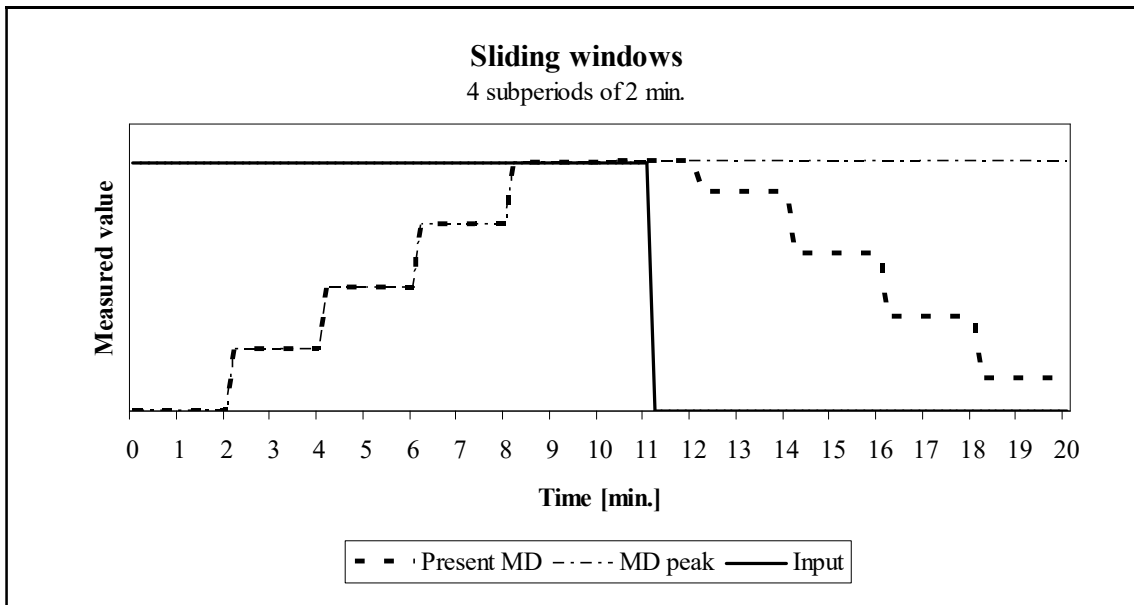

#### 8.4.7.3 Thermal demand

The thermal demand option will provide an exponential thermal characteristic, based on the bimetal element principal. Maximum demand and the time of its occurrence are stored in the unit. Note that the **M213** only has this technique.

Maximal values and time of their occurrence are stored in **M2x3**. A time constant (t. c.) can be set from 1 to 255 minutes and is 6-time thermal time constant (t.c. = 6 \* thermal time constant).

Example:

Mode: Thermal function  
Time constant: 8 min.  
Current MD and maximal MD: Reset at 0 min.

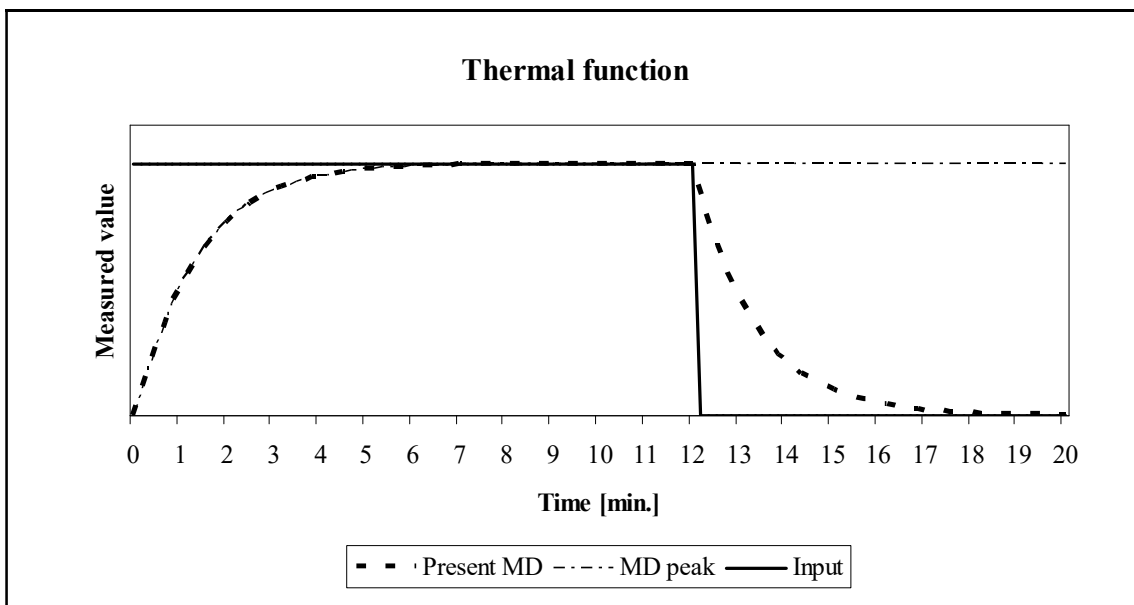

#### 8.4.7.4 Resetting min/max values

The Min/Max demand values can be reset using either manual or automatic modes. The automatic mode can reset the period each day at midnight (time 00:00), weekly (Monday at 00:00), monthly (first day at 00:00) or yearly (first day of the year at 00:00)

## 8.5 Power Quality

The **M253** provides a quality of supply monitor that complies with the European standard EN50160. This power quality standard is used to monitor electrical systems and ensure that it falls within several different limits ensuring that the user has a consistent and correct supply of electricity. The **M253** has 2MB of non-volatile memory reserved for storing data with a capacity for storing 170,000 variations from standard.

The EN50160 standard monitors the following electrical characteristics:

- Frequency and voltage variations
- Voltage unbalances, interruptions, and dips
- Long and Transient (fast) interruptions
- Flicker, short and long term
- Individual Harmonics and %THD

All the Power Quality settings, extraction and tabulation of findings require the **QDSP Professional** software.

The following definitions are used in Power Quality applications:

Un = nominal supply voltage for the electrical system

Uc = agreed supply voltage for the electrical system, this may be the same as Un.

The Power Quality information can be displayed on the graphical LCD display, see section 12.3 for the available options and section 12.7 for the Power Quality report functions.

### 8.5.1 Frequency and voltage variations

All frequency and voltage variations are averaged over a 10 second interval. The measured value is defined as a % from the nominal value and the number of variations over time is also defined by the user.

### 8.5.2 Voltage interruptions and dips

All interruptions and dips are defined as a % change from the nominal voltage, the difference is that an interruption is classified as falling to 1% of nominal whilst a dip is generally about 90% of nominal. The time that the variation occurs is also classified over time, generally between ½ cycle to 1 minute.

### 8.5.3 Fast voltage changes

A limit is defined as the number of variations within a pre-set time, each variation is measured as a %change from the nominal slope over time (%Un/t).

### 8.5.4 Flicker - short term

Short term flicker intensity is measured over a 10 minute period and is calculated as:

$$P_{50S} = (P_{30} + P_{50} + P_{80})/3$$

$$P_{10S} = (P_6 + P_8 + P_{10} + P_{13} + P_{17})/5$$

$$P_{3S} = (P_{2,2} + P_3 + P_4)/3$$

$$P_{1S} = (P_{1,7} + P_1 + P_{1,5})/3$$

$$P_{st} = \sqrt{0,0314P_{0,1} + 00525P_{1S} + 0,0657P_{3S} + 0,28P_{10S} + 0,08P_{50S}}$$

#### **Flicker - short term intensity**

P<sub>x</sub> - flicker levels that are exceeded by x% in a ten-minute period.

(e.g. P<sub>0,1</sub> represents a flicker level that is exceeded by 0.1% samples)

## 8.5.5 Flicker - long term

$$P_{lt} = \sqrt[3]{\sum_{i=1}^{12} \frac{P_{sti}^3}{12}}$$

**Flicker - long term intensity**

Calculated from twelve successive values of short-term flicker intensity in a two-hour period

## 9. HARDWARE

### 9.1 Communications

The **M2x3** can be supplied with either an RS232/RS485, USB or Ethernet electrically isolated communications that must be specified at ordering. The communication protocols that are available are MODBUS RTU and TCP, which are detailed in a separate manual. The communications service enables remote viewing of measurements and viewing and setting of system parameters. Figure 10-1 shows the DB9 connector on the rear of the **M2x3** case, Serial via terminals, Ethernet and/or USB connectors can replace the DB9 connector.

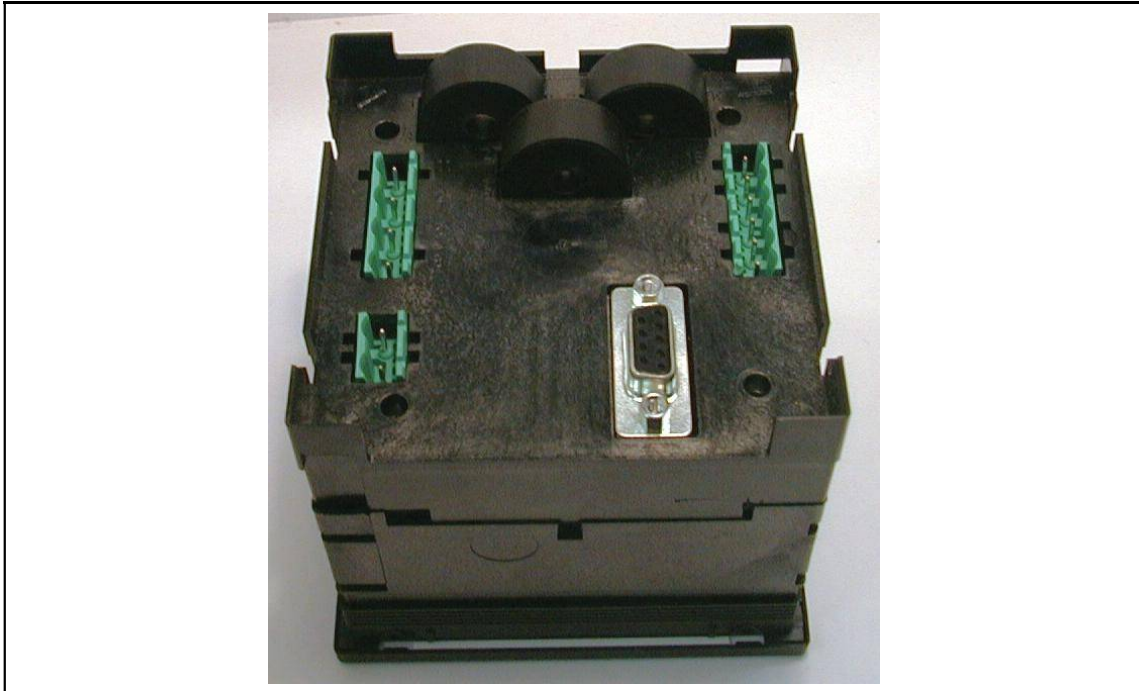

FIGURE 10-1 : M2X3 REAR CASE VIEW

#### 9.1.1 RS232 /RS485 communications

The **M233**, **M243** and **M253** communicating meters have the option of either a rear mounted DB9 9 pin connector that is used for both RS232 and RS485 communications, or separate terminals for RS232 or RS485 communications.

The DB9 port must be user wired as either RS232 or RS485 since the port cannot support both options at the same time. With the terminal connections, although connectors for both RS232 and RS485 are provided only one connector can be wired at one time.

**WARNING: DO NOT ATTEMPT TO CONNECT USING RS232 AND RS485 COMMUNICATIONS AT THE SAME TIME AS DAMAGE CAN OCCUR. LEAVE THE UNUSED PINS IN DB9 AND ON TERMINALS UNCONNECTED.**

The connection of RS232 communications has a maximum cable length is 15 metres.

Two-wire RS485 communications enables simultaneous connection to a maximum of 32 communicating devices, over distances of 1000m. For long cable distances a terminating resistor (120 ohm) may have to be connected between the 2 wires at the extreme ends of the cable network.

Connection information will be shown on the label as depicted in table 10-1.

Connection					DB9 connector																										
<table border="1"> <tr><th colspan="5">COMMUNICATION</th></tr> <tr><th colspan="3">RS232</th><th colspan="2">RS485</th></tr> <tr><th>Tx</th><th>Rx</th><th>⏏</th><th>B</th><th>A</th></tr> <tr><td>2</td><td>3</td><td>5</td><td>7</td><td>8</td></tr> </table>					COMMUNICATION					RS232			RS485		Tx	Rx	⏏	B	A	2	3	5	7	8							
COMMUNICATION																															
RS232			RS485																												
Tx	Rx	⏏	B	A																											
2	3	5	7	8																											
Connection					Terminals																										
<table border="1"> <tr><th colspan="5">COMMUNICATION</th></tr> <tr><th colspan="5">TERMINAL</th></tr> <tr><th colspan="3">RS485</th><th colspan="2">RS232</th></tr> <tr><th>A</th><th>B</th><th>Rx</th><th>⏏</th><th>Tx</th></tr> <tr><td>21</td><td>22</td><td>23</td><td>24</td><td>25</td></tr> </table>					COMMUNICATION					TERMINAL					RS485			RS232		A	B	Rx	⏏	Tx	21	22	23	24	25		
COMMUNICATION																															
TERMINAL																															
RS485			RS232																												
A	B	Rx	⏏	Tx																											
21	22	23	24	25																											

TABLE 10-1 : RS232/RS485 CONNECTIONS

9.1.2 Ethernet communications

The **M233**, **M243** and **M253** communicating meters can have a rear mounted RJ45 Ethernet connector.

If both Ethernet and USB ports are fitted, they can be used simultaneously allowing interrogation locally and remotely at the same time.

Note that each **M2x3** will have a unique MAC number indicated on the label that can be used when configuring the Ethernet communications.

Connections									
<table border="1"> <tr><th colspan="2">COMMUNICATION</th></tr> <tr><td colspan="2">Ethernet</td></tr> <tr><td colspan="2">MAC No.: 00-1B-DF-54-7B-4A</td></tr> <tr><td colspan="2">USB 2.0 Type B</td></tr> </table>		COMMUNICATION		Ethernet		MAC No.: 00-1B-DF-54-7B-4A		USB 2.0 Type B	
COMMUNICATION									
Ethernet									
MAC No.: 00-1B-DF-54-7B-4A									
USB 2.0 Type B									

TABLE 10-1B : ETHERNET/USB

9.1.3 USB communications

The **M233**, **M243** and **M253** communicating meters can be supplied with a USB port, via a rear mounted USB type B connector.

USB communication serves as a fast peer-to-terminal data link. The instrument is detected by the host as a USB 2.0 compatible device.

If both Ethernet and USB ports are fitted, they can be used simultaneously allowing interrogation locally and remotely at the same time.

9.2 Inputs and Outputs

The **M2x3** (except for the **M203**) can be supplied with two hardware modules situated on the rear of the case. These ports can be factory configured to one of the following options as shown in table 10-2:

TABLE 10-2 : I/O OPTIONS	M203	M213	M233	M243	M253
2x energy contacts		●	●	●	●
2x tariff inputs		●	●	●	●
2x alarm contacts			●	●	●
2x analogue outputs			●	●	●
1x Watchdog & 1x alarm contact			●	●	●
1x bistable alarm contact			●	●	●
2x digital inputs			●	●	●
2x analogue input			●	●	●
2x pulse input			●	●	●
1x RS485 port			●	●	●
1x RS232 port			●	●	●

Since each hardware module is independent from the other, the **M2x3** can be supplied with two different modules (for example 2 energy contacts and 2 alarm contacts) or with two similar modules (for example 4 analogue outputs or 4 tariff inputs).

**I/O hardware module 1 uses terminals 15/16/17 and module 2 uses 18/19/20.**

9.2.1 Energy pulse outputs

The 2 energy pulsed outputs that can be used for external monitoring of energy consumption. The energy measuring via the pulsed outputs corresponds to the basic energy measurement on the **M2x3** display. The pulsed outputs' energy measurement can be adapted to the customer's needs via the remote communications link.

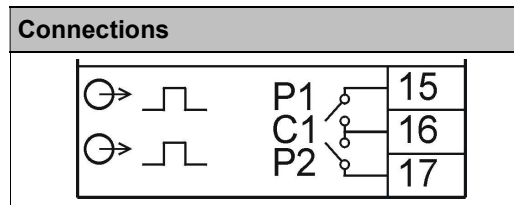

TABLE 10-3 : DUAL ENERGY CONTACTS

The hardware module has three terminals, the energy contacts will share a common connection, but each contact can be individually set. When both hardware modules are used for energy contacts, the **M2x3** will provide a maximum of 4 independent outputs.

9.2.2 Tariff (inputs)

The 2 tariff inputs can be used for signalling different tariff periods. The tariff period would be used in conjunction with the Cost Management feature to determine the financial value of energy being monitored. This corresponds to the energy costs on the **M2x3** display. The tariff structure can be adapted to the customer's needs via the remote communications link.

The hardware module has three terminals (see table 10-4), the tariff voltage input is 230Vac ± 20% and share a common connection but each input can be individually set. When both hardware modules are used for tariff applications, the **M2x3** will provide a maximum of 4 independent inputs.

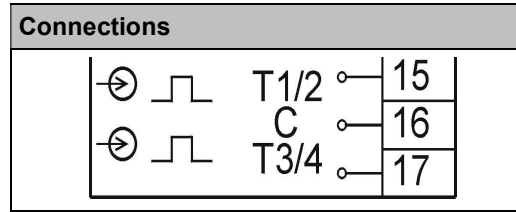

TABLE 10-4 : TARIFF INPUTS

9.2.3 Alarm and bistable contacts (outputs)

The 2 alarm contacts can be used for external monitoring of an alarm condition. The alarms can be set via the front menu on the **M2x3** display or can be adapted to the customer's needs via the remote communications link.

The hardware port has three terminals (see table 10-5), the alarm contacts will share a common connection, but each contact can be individually set. When both hardware ports are used for the alarm contacts, the **M2x3** will provide a maximum of 4 independent outputs.

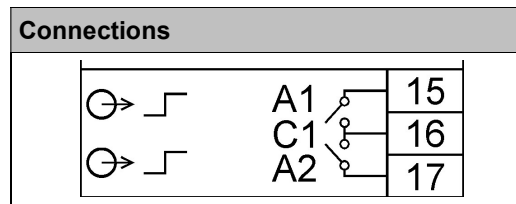

TABLE 10-5 : ALARM CONTACTS

Alternatively, the **M2x3** can be supplied with each port as a bistable or change-over contact, in this application there will be a maximum of 2 independent outputs, see table 10-6.

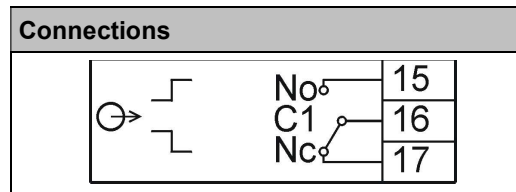

TABLE 10-6 : BISTABLE ALARM

9.2.4 Analogue (outputs)

The **M2x3** hardware port can be supplied as 2 analogue outputs, each of which can be set within the range 0...20mA. The analogue output can be configured to represent any of the instantaneous measured values. The outputs can be set via the front menu on the **M2x3** display or can be adapted to the customer's needs via the remote communications link.

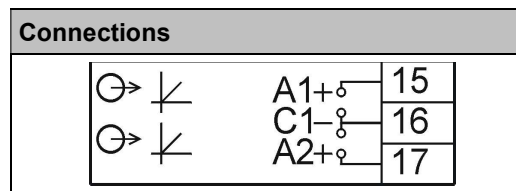

TABLE 10-7 : ANALOGUE OUTPUTS

The hardware port has three terminals (see table 10-7), the analogue outputs will share a common connection, but each output can be individually set. When both hardware ports are used as an analogue output, the **M2x3** will provide a maximum of 4 independent outputs.

9.2.5 Digital inputs

The **M2x3** hardware port can be supplied as 2 digital inputs able to read the status of the line. Various voltage values are available, see the ordering cortec. The status of a digital input is defined as one of the 32 alarms available on the system and can be monitored remotely via the communications.

The hardware port has 3 terminals (see table 10-8) sharing an input common terminal. When both hardware ports are used as a digital input, the **M2x3** will provide a maximum of 4 independent inputs.

Connections		
	D1	15
	C	16
	D2	17

TABLE 10-8 : DIGITAL INPUTS

9.2.6 Watchdog output and alarm output (combined)

The **M2x3** can be supplied with a module that combines a Watchdog output and an Alarm Relay. The Alarm relay operates as if it is a part of an Alarm Output module.

The module has 3 terminals (see TABLE 10-9) sharing an output common terminal.

When both hardware ports use this module, the **M2x3** can have 2 Watchdog outputs and 2 Alarm outputs.

Connections		
<b>I/O 1/2</b>		
<b>Watchdog / Relay output</b>		
35 V DC	WD 1	15
40 V AC	RE 2	16
1000 mA		17

TABLE 10-9: WATCHDOG AND ALARM OUTPUTS

9.2.7 Analogue input

The **M2x3** hardware port can be supplied as 2 analogue inputs. Various options are available, see the ordering cortec.

The module has 3 terminals (see TABLE 10-10).

When both hardware ports are analogue inputs, the **M2x3** can provide a maximum of 4 analogue inputs.

Connections		
<b>I/O 1/2</b>		
<b>2 x Analogue input</b>		
0...-/±10 V	+	15
	-	16
	+	17

TABLE 10-10: ANALOGUE INPUTS

9.2.8 Pulse input

The **M2x3** hardware port can be supplied as 2 pulse inputs.

The module has 3 terminals (see TABLE 10-11).

When both hardware ports are pulse inputs, the **M2x3** can provide a maximum of 4 pulse inputs.

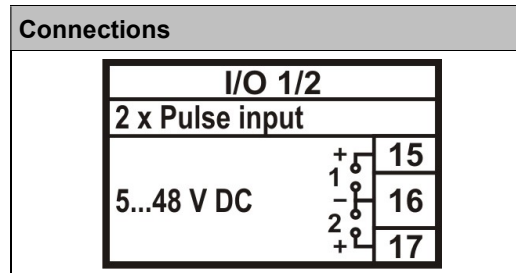

TABLE 10-11: PULSE INPUTS

9.2.9 2<sup>nd</sup> RS485 communications (COM2)

The **M2x3** hardware port 2 can be supplied as a second RS485 communications port (COM2) which is completely independent of the main communications port (COM1)

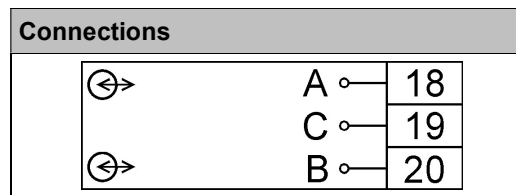

TABLE 10-12 : RS485 (COM2)

The hardware port has 3 terminals (see table 10-12) to provide a RS485 port. Only one additional RS485 port (COM2) can be fitted, and it must be in hardware port 2.

9.2.10 2<sup>nd</sup> RS232 communications (COM2)

The **M2x3** hardware port 2 can be supplied as a second RS232 communications port (COM2) which is completely independent of the main communications port (COM1)

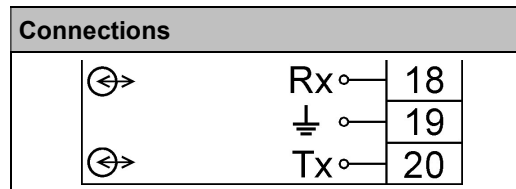

TABLE 10-13 : RS232 (COM2)

The hardware port has 3 terminals (see table 10-13) to provide a RS232 port. Only one additional RS232 port (COM2) can be fitted, and it must be in hardware port 2.

### 9.3 Memory Card

All the **M2x3** family have a memory card slot located on the front display where the memory card is inserted, see figure 10-2. Section 11.5 describes the operation of the memory card.

The memory card slot on all **M2x3** products will accept a MultiMediaCard (MMC). In addition, **M233**, **M243** and **M253** products using Version 'C' Hardware will also accept an SD card. Cards with memory sizes up to 1GB are supported.

The memory card is only used for transferring data; it cannot be used as an extension to the logging memory of the meter. Therefore, the memory card should not be left in the slot in the meter and the slot cover should be fitted to prevent ingress of moisture and dust.

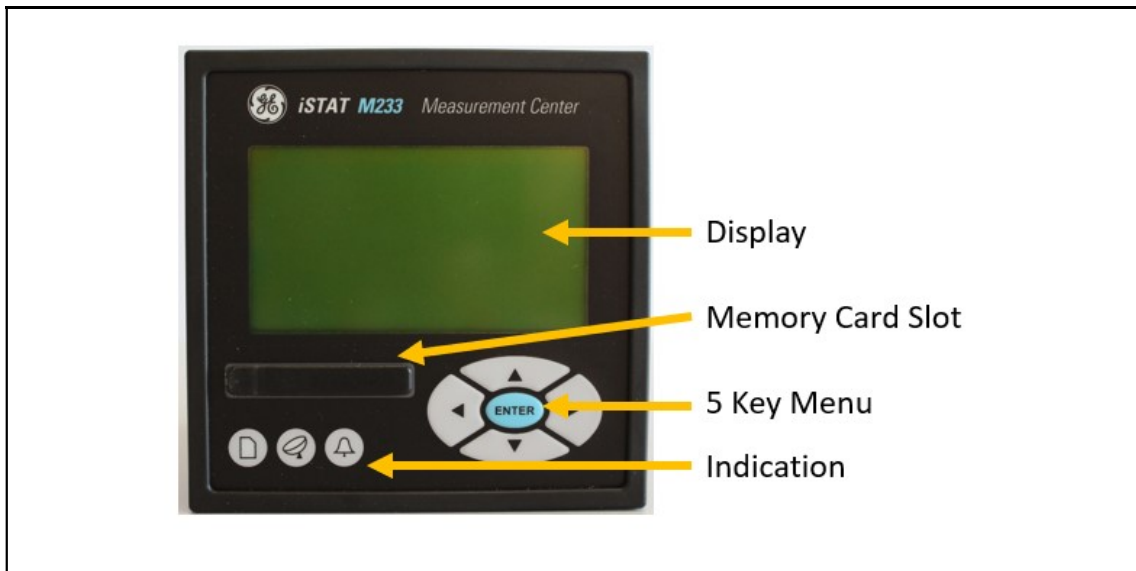

FIGURE 10-2 : M2X3 FRONT PANEL

The memory card is used to load the **M2x3** settings and to extract records from the **M243** and **M253**. This means that the settings for all the **M2x3** can be made offline using QDSP and loaded into the **M2x3**, including the **M203** and **M213** which are non-communicating.

The options available for the memory card are fully described in section 11.5: Memory Card Status, Save Data, Load Settings, and Software Update.

**Memory Card Status:** the **M2x3** can check the status of the memory card ensuring that it is correctly located in the front slot and that it can be read from and written to.

**Save Data:** Where the **M2x3** has a recording function, such as the **M243** data logger or the **M253** Power Quality recorder, this data can be saved to the memory card for offline analysis using the QDSP software.

**Load Settings:** the settings for the **M2x3** are compiled in QDSP using a .msf file suffix. This file can be saved on a computer or onto the memory card. The memory card is then inserted into the **M2x3**, and these settings loaded into the **M2x3**. The **M2x3** will only load the appropriate .msf file so that the settings from one meter cannot be inadvertently loaded into another inappropriate meter.

**Software Update:** QDSP has an upgrade function for the **M2x3** firmware. This firmware can be saved onto the memory card and then transferred to the **M2x3** so that the meter firmware can be upgraded. This removes the need for the **M2x3** (especially non communicating versions) to be returned to the factory for an upgrade.

### 9.4 Auxiliary Supply

The **M2x3** family can either have an AC auxiliary voltage that must be specified or a single Universal ac/dc auxiliary voltage supply.

Parameter	AC Auxiliary Voltage	Universal Auxiliary Voltage
AC Nominal Voltage	57.7V, 63.5V, 100V, 110V, 230V or 400Vac	48 – 276V ac
Frequency	45 – 65Hz	40 – 70Hz
DC Nominal Voltage	n/a	20 – 300Vdc
urden	< 8 VA	< 12 VA

TABLE 10-14: AUXILIARY SUPPLY

9.4.1 Inputs and supply

The **M2x3** has an auto-ranging voltage and current input with a nominal 500V and 5A. Since the **M2x3** also has a fully configurable connection mode the default information is shown as 4u (3 phase 4 wire unbalanced), and the default connection diagram also shows this connection. This information is combined with the auxiliary supply and shown on the label as follows; the different wiring connections are shown in section 15.

SUPPLY:		
20...300 V DC <12VA		
48...276 V; 40...70 Hz		
Terminal	13	≅
	14	≅

TABLE 10-15: UNIVERSAL POWER SUPPLY

SUPPLY:		
230 V AC		
45...65 Hz		
Terminal	13	~
	14	~

Table 10-16: AC POWER SUPPLY

## 10. PROGRAMMING THE M2X3

The basic programming **M2x3** can be programmed using the display and keypad on the device. The **M233**, **M243** and **M253**, which are always fitted with communications, can also be programmed using the QDSP software. There are many options on the **M233**, **M243** and **M253** that can only be programmed using the QDSP software. See section 14 for details.

### 10.1 Menu Introduction

The settings, measurements, and functions of the **M2x3** can be accessed from either the front panel or the remote communications link. The menu structure of the **M2x3** is navigated using the five keys on the front panel as shown in figure 11-1 below:

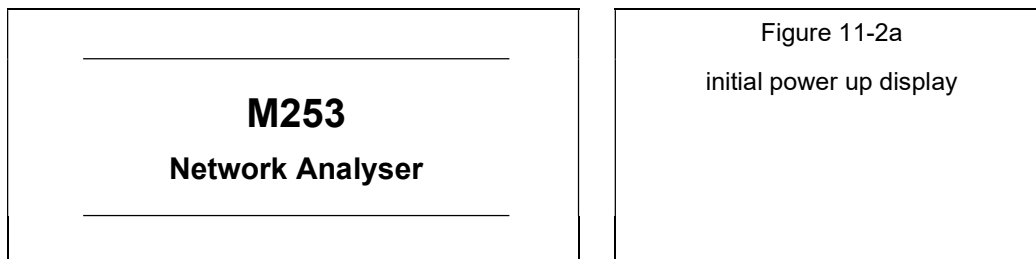

FIGURE 11-1: M2X3 FRONT VIEW

Throughout this section the following symbols are used to relate to pressing the corresponding key on the front panel.

Key	Left	Right	Down	Up	Enter
Symbol	◀	▶	▼	▲	OK

The **M2x3** is supplied with the Level 1 and Level 2 passwords set to AAAA. AAAA passwords offer no level of protection; all measurements and settings can be modified. The passwords must be changed from AAAA to activate password level protection.



When the **M2x3** is first connected to the auxiliary power system, the user is greeted with the message shown in Figure 11-2a above. This information will be displayed for a few seconds before the main menu is shown, see Figure 11-2b below.



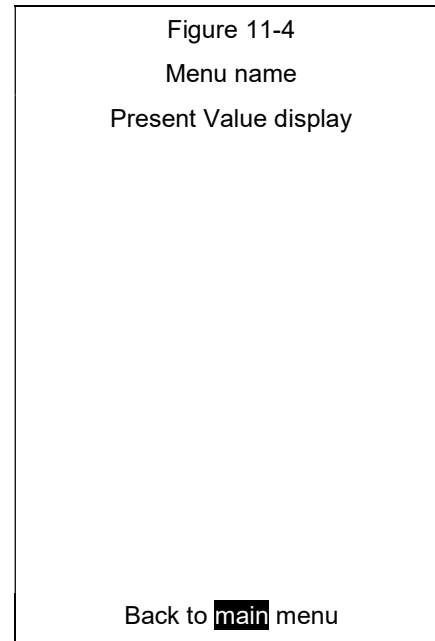
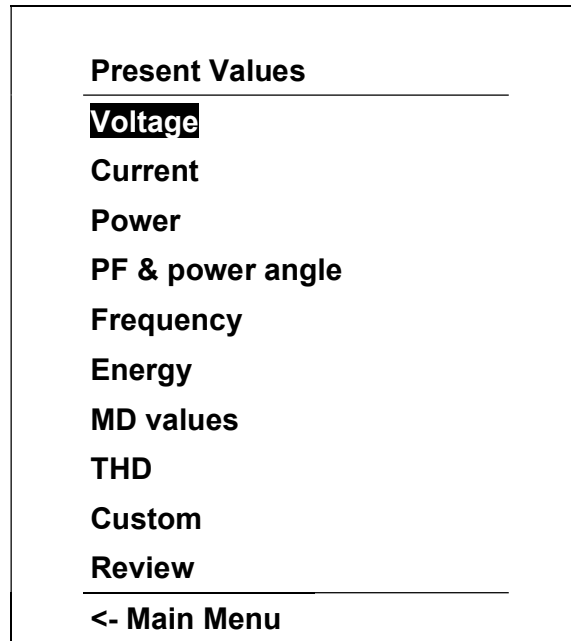

table 11-1 illustrates the **Measurement Menu** information structure. The user can browse through all the available menus using the direction keys. Pressing the **OK** key returns to the **Measurement Menu**

	Information	<Left									Right>
▲	Voltage		Phase Voltage	Line Voltage							
	Current	Average Current	Phase Current								
	Power	W, VA and VAR total	W per phase	VA per Phase	VAR per phase						
	PF and power angle	PF total Power angle total	PF per Phase	Power angle per Phase							
	Frequency	Frequency									
	Energy	Counters 1 & 2	Counters 3 & 4	Counter 1 history	Counter2 history	Counter3 history	Counter4 history	Energy Price			
	MD values	w	w	va	va	var	var	Iphase1	Iphase2	Iphase3	
	THD	Phase Current	Phase Voltage	Line Voltage							
	Custom	User defined 1	User defined 2	User defined 3							
▼	Overview	Voltage current, Watts and VARs	Voltage current, Watts and VARs	Voltage current, Watts and VARs							

TABLE 11-1 : **MEASUREMENT MENU** INFORMATION STRUCTURE

### 10.3 Settings Navigation

Figure 11-5 illustrates the **settings** menu structure. The user can browse through the 8 available menus using the direction keys, by pressing the DOWN▼ or UP▲ keys and then pressing the **OK** key to select. The ◀LEFT key is pressed to return to the **Main Menu**.

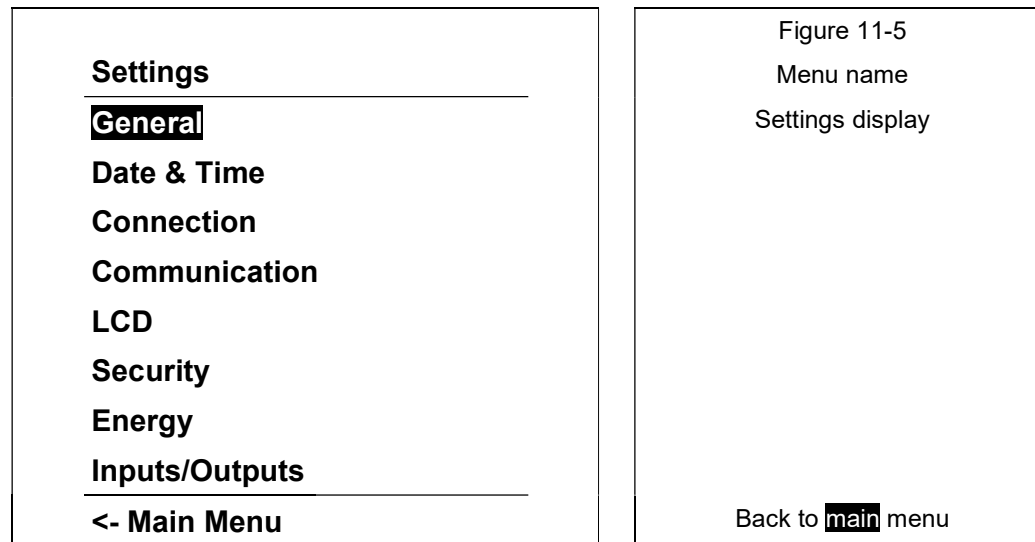

table 11-2 illustrates the **Settings Menu** information structure. The user can browse through all the available menus using the direction keys. Pressing the **OK** key returns to the **Settings Menu**. The settings that appear will depend on the model and the optional modules fitted.

	◀Left							Right▶
▲	General	Date & Time	Connection	Communication	LCD	Security	Energy	Inputs/ Outputs
	Language	Date	Connection mode	Device address	Contrast	Password level 1	Active tariff	I/O 1
	Currency	Time	VT primary	Baud rate	Backlight	Password level 2	Common en. component	I/O 2
	Temperature unit	Date format	VT secondary	Parity	Backlight time off	Password lock time		I/O 3
	MD mode	Auto S/W time	CT primary	Stop bit	Demo cycling period	Lock instrument		I/O 4
	MD time constant		CT secondary		Custom screen 1	Unlock instrument		
	Average interval				Custom screen2			
▼	Min/Max reset mode				Custom screen3			

TABLE 11-2 : **SETTINGS MENU** INFORMATION STRUCTURE.

**10.4 Resets Navigation**

Figure 11-6 illustrates the **resets menu** structure. The user can browse through the 6 available menus using the direction keys, by pressing the DOWN▼ or UP▲ keys and then pressing the **OK** key to select. The **LEFT** key is pressed to return to the **Main Menu**

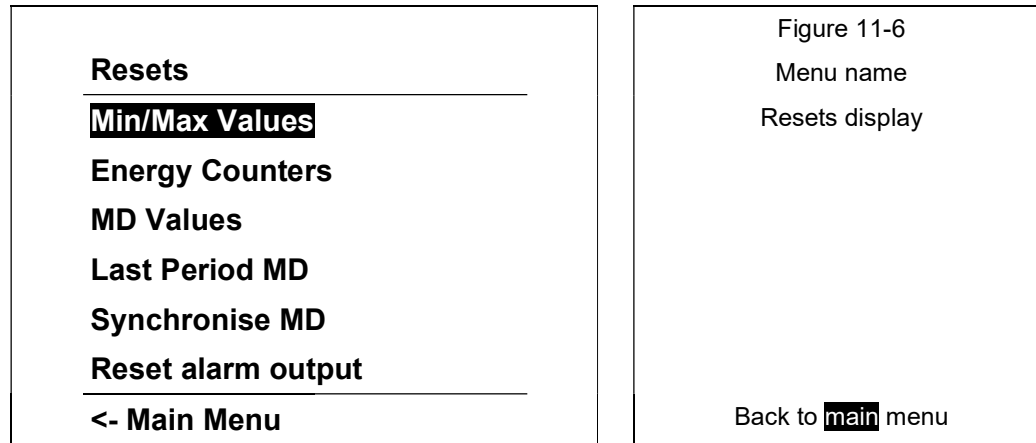

table 11-3 illustrates the **Resets Menu** information structure. The user can browse through all the available menus using the direction keys. Pressing the **OK** key returns to the **Resets Menu**. The settings that appear will depend on the model and the optional modules fitted.

	◀Left					Right▶
▲	Min/max values	Energy counters	MD values	Last period MD	Synchronise MD	Reset Alarm output
	No/Yes	All energy counters	No/Yes	No/Yes	No/Yes	No/Yes
		All cost counters				
		Energy counter E1				
		Energy counter E2				
		Energy counter E3				
		Energy counter E4				
		Cost counter E1				
		Cost counter E2				
		Cost counter E3				
▼		Cost counter E4				

TABLE 11-3 : **RESETS MENU** INFORMATION STRUCTURE

**10.5 Memory Card Navigation**

Figure 11-7 illustrates the **Memory card** menu structure; the same controls apply to the SD Card if accepted. The user can browse through the 4 available menus using the direction keys, by pressing the ▼DOWN or ▲ UP keys and then pressing the **OK** key to select. The **LEFT** key is pressed to return to the **Main Menu**

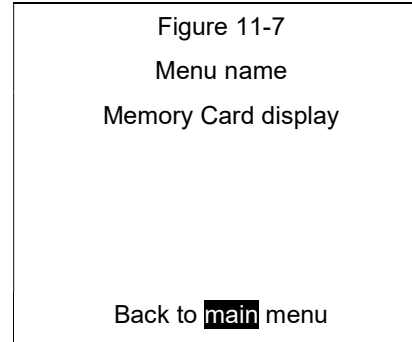
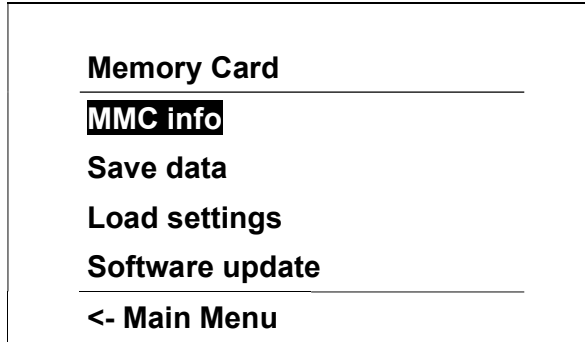

Table 11-4 illustrates the **MMC Menu** information structure. The user can browse through all the available menus using the direction keys. Pressing the **OK** key returns to the **MMC Menu**. The settings that appear will depend on whether the MMC card is inserted. If the MMC is not inserted the message **MMC not inserted!** will appear.

	<Left			Right>
▲	MMC info	Save data	Load settings	Software update
	?	Recorder A	?	?
		Recorder B		
		Alarms		
		Q details		
		Q reports		
▼				

TABLE 11-4 : **MMC MENU** INFORMATION STRUCTURE

10.6 Info Navigation

Figure 11-8 illustrates the **Product Identify** display; this is also the default display during power up. This will not refresh back to the main menu, so the user has to press the **< LEFT** key to get back to the **Main Menu**.

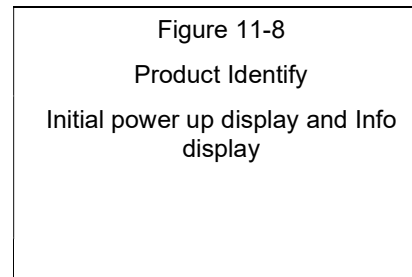
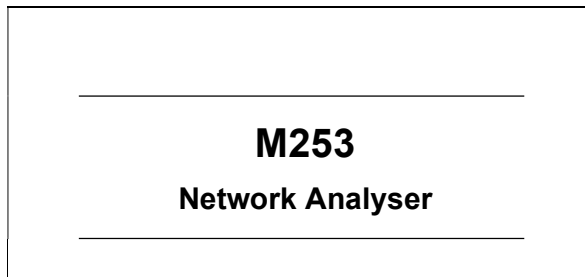
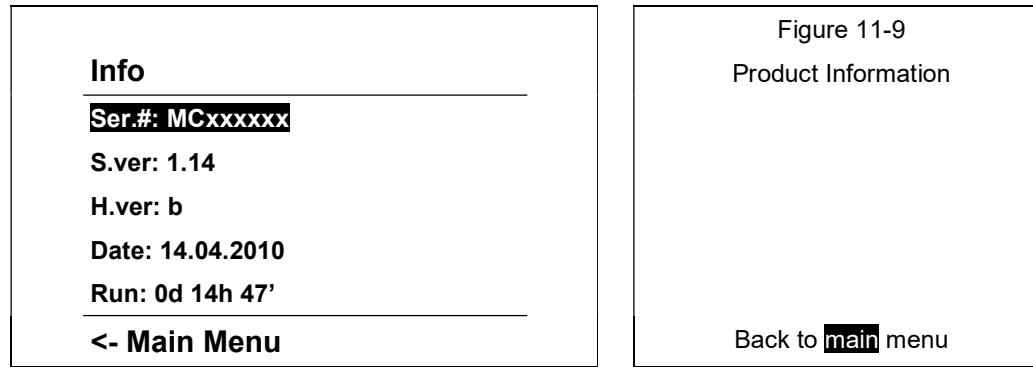

Figure 11-9 illustrates the **Product Information** display. This is viewed by pressing either the **▼ DOWN** or **▲ UP** keys. Pressing the **< LEFT** key to takes the user back to the **Main Menu**.



The information shown on the **Product Information** display is:

**Ser.#: MCxxxxxx** this is the **M2x3** serial number.

**S.ver: 1.14:** this is the software version loaded in the **M2x3**

**H.ver: b** this is the hardware version of the **M2x3**

**Date: 14.04.2010:** this is the date that the **M2x3** software was last upgraded

**Run: 0d 14h 47':** this is the total time that the **M2x3** has been operating

## 10.7 Installation Navigation

Figure 11-10 illustrates the **Installation** menu structure. The user presses **OK** key to select. The **<LEFT** key is pressed to return to the **Main Menu**

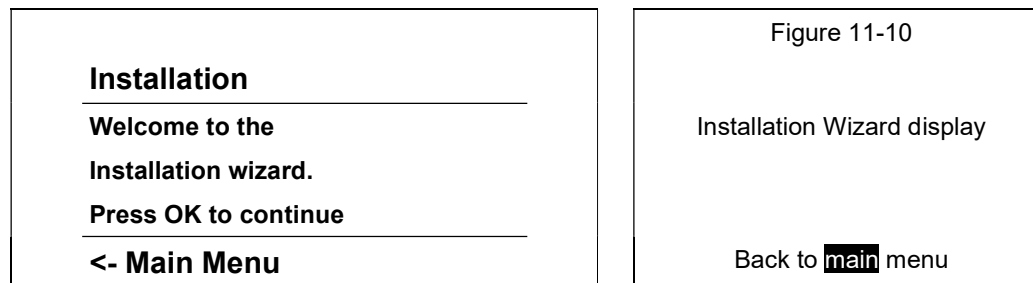

The Installation Wizard is described in section 12.1.

## 11. MEASUREMENT MENU FUNCTIONS

### 11.1 Installation Wizard

The Installation Wizard is designed to take the user through the minimum functions necessary to install the **M2x3**. By pressing the **OK** key, the following functions can be set: Language; Date; Time; Connection Mode; VT Primary; VT Secondary; CT Primary; CT Secondary; Device Address; Baud Rate; Parity; Stop Bit.

From the Installation Wizard located on the Main Menu, press **OK** to activate the Wizard.

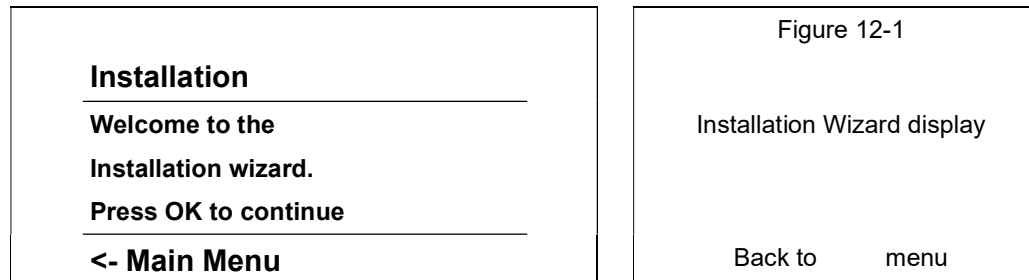

Figure 12-2 shows the **Language** setting structure. The selection is made by pressing either the **▼ DOWN** or **▲ UP** keys until the desired language is selected and then press **OK** key to select.

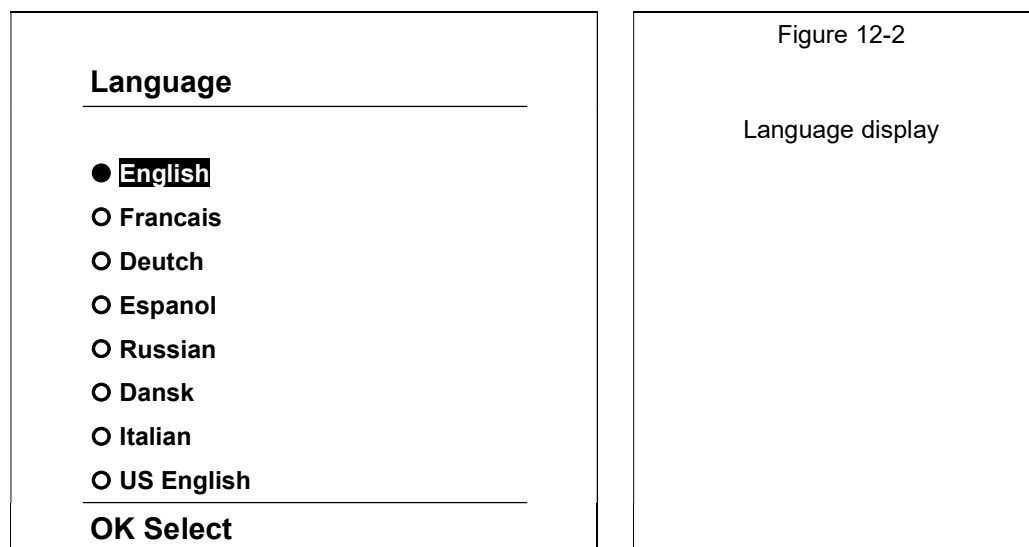

Figure 12-3 shows the **Date** setting structure, the format is date: month: year. An underscore shows the position of the cursor. Move along the date by using the **► RIGHT** or **◀ LEFT** key, changes are made by pressing either the **▼ DOWN** or **▲ UP** keys until the desired setting is shown, then press **OK** key to confirm. The **◀ LEFT** key can be pressed to return to the **Language** menu.

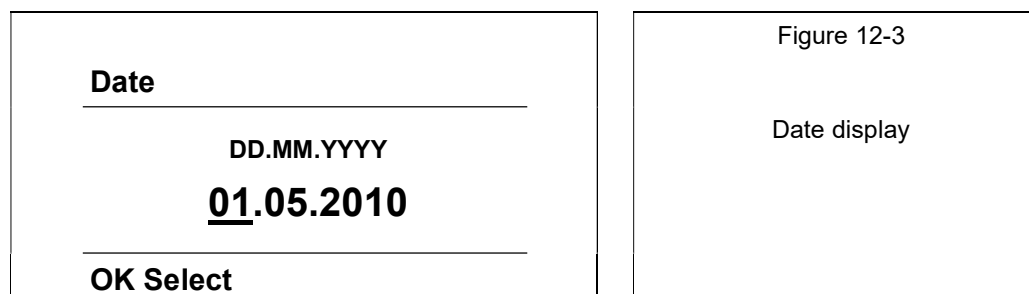

Figure 12-4 shows the **Time** setting structure, the format is hours: minutes: seconds. An underscore shows the position of the cursor. Move along the date by using the ► RIGHT or ◀ LEFT key, changes are made by pressing either the ▼ DOWN or ▲ UP keys until the desired setting is shown, then press **OK** key to confirm. The ◀ LEFT key can be pressed to return to the **Date** setting.

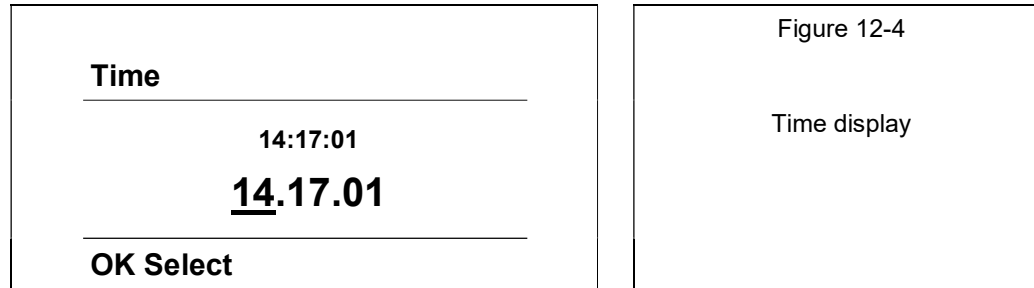

Figure 12-5 shows the **Connection Mode** setting structure. The selection is made by pressing either the ▼ DOWN or ▲ UP keys until the desired connection mode is selected and then press **OK** key to confirm. The ◀ LEFT key can be pressed to return to the **Time** setting.

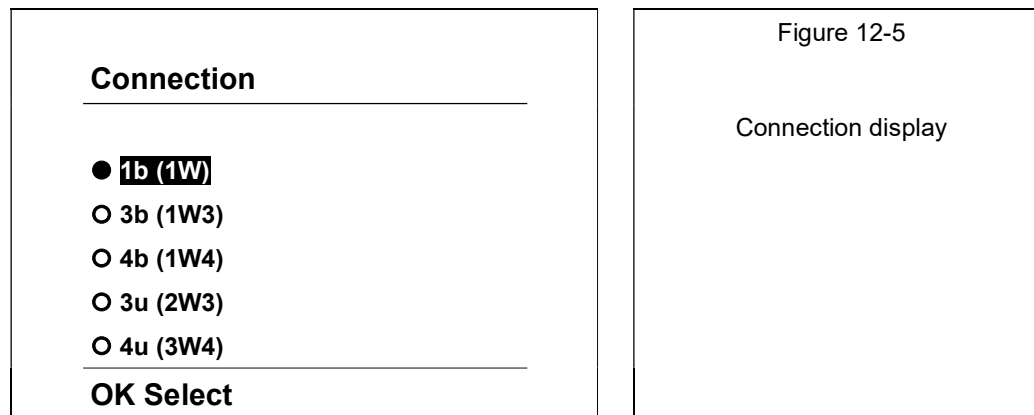

Figure 12-6 shows the **VT Primary** setting structure. An underscore shows the position of the cursor. Move along by using the ► RIGHT or ◀ LEFT key, changes are made by pressing either the ▼ DOWN or ▲ UP keys until the desired setting is shown, then press **OK** key to confirm. When the cursor is under the decimal point, the engineering units (V, KV) can be changed. The ◀ LEFT key can be pressed to return to the **Connection Mode** setting.



Figure 12-7 shows the **VT Secondary** setting structure. An underscore shows the position of the cursor. Move along by using the ► RIGHT or ◀ LEFT key, changes are made by pressing either the ▼ DOWN or ▲ UP keys until the desired setting is shown, then press **OK** key to confirm. The ◀ LEFT key can be pressed to return to the **VT Primary** setting.

**VT secondary**

---

**\_110.0V**

---

**OK Select**

Figure 12-7

VT Secondary display

Figure 12-8 shows the **CT Primary** setting structure. An underscore shows the position of the cursor. Move along by using the ► RIGHT or ◀ LEFT key, changes are made by pressing either the ▼ DOWN or ▲ UP keys until the desired setting is shown, then press **OK** key to confirm. When the cursor is under the decimal point, the engineering units (A, KA) can be changed. The ◀ LEFT key can be pressed to return to the **VT Secondary** setting.

**CT primary**

---

**\_2800.0A**

---

**OK Select**

Figure 12-8

CT Primary display

Figure 12-9 shows the **CT Secondary** setting structure. An underscore shows the position of the cursor. Move along by using the ► RIGHT or ◀ LEFT key, changes are made by pressing either the ▼ DOWN or ▲ UP keys until the desired setting is shown, then press **OK** key to confirm. The ◀ LEFT key can be pressed to return to the **CT Primary** setting.

**CT secondary**

---

**\_5.0A**

---

**OK Select**

Figure 12-9

CT Secondary display

Figure 12-10 shows the **Device address** setting structure. An underscore shows the position of the cursor. Move along by using the ► RIGHT or ◀ LEFT key, changes are made by pressing either the ▼ DOWN or ▲ UP keys until the desired setting is shown, then press **OK** key to confirm. The ◀ LEFT key can be pressed to return to the **CT secondary** setting. The default address is 33.

**Device address**

---

**\_33**

---

**OK Select**

Figure 12-10

Device address display

Figure 12-11 shows the **Baud Rate** setting structure. Changes are made by pressing either the ▼ DOWN or ▲ UP keys until the desired setting is shown, then press **OK** key to confirm. The ◀ LEFT key can be pressed to return to the **Device Address** setting.

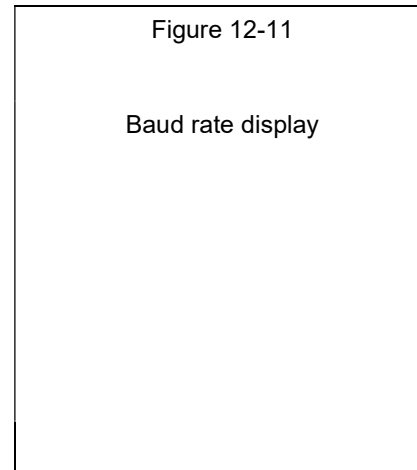
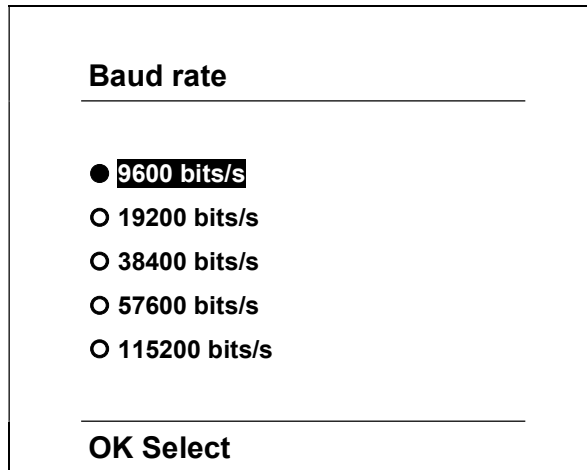

Figure 12-12 shows the **Parity** setting structure. Changes are made by pressing either the **▼** DOWN or **▲** UP keys until the desired setting is shown, then press **OK** key to confirm. The **◀** LEFT key can be pressed to return to the **Baud Rate** setting.

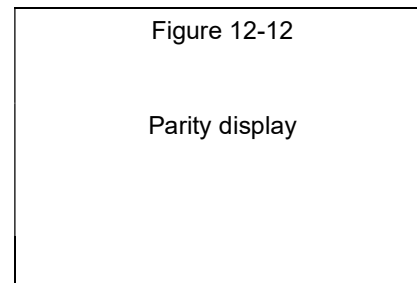
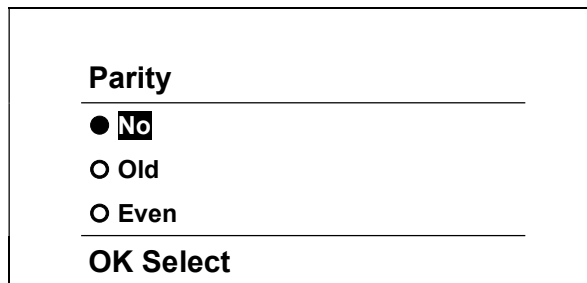

Figure 12-13 shows the **Stop Bit** setting structure. Changes are made by pressing either the **▼** DOWN or **▲** UP keys until the desired setting is shown, then press **OK** key to confirm. The **◀** LEFT key can be pressed to return to the **Parity** setting.

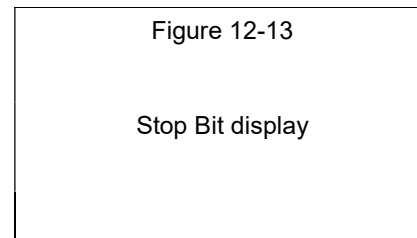
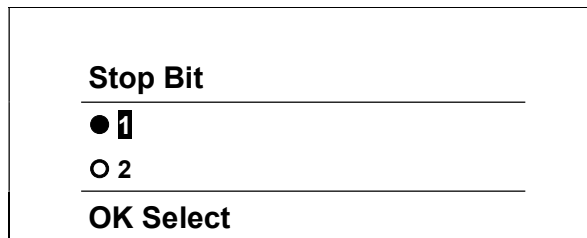
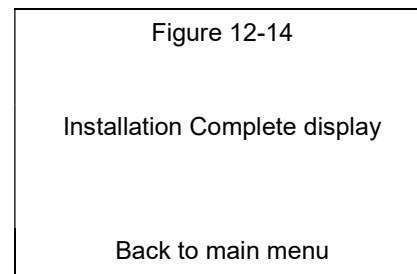
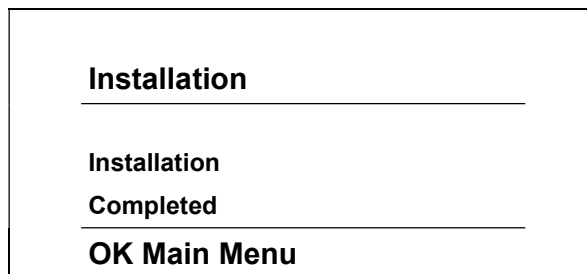

Figure 12-14 shows the **Installation Completed** display. Press **OK** key to confirm all the changes and complete the installation.



## 11.2 Demo Cycling

The function polls through several different displays that show the different features that are in the **M2x3**. The features shown will depend on the model of **M2x3** that is used.

Figure 12-15 illustrates the **Measurement** menu structure. The user can browse through the 7 available menus using the direction keys, by pressing either the DOWN **▼** or UP **▲** keys and then pressing the **OK** key to select the **Demo Cycling** Menu.

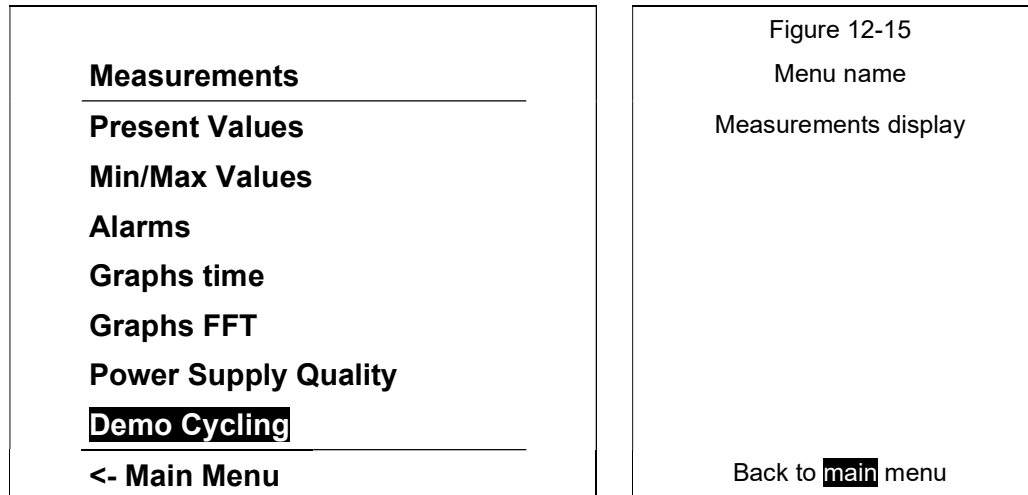
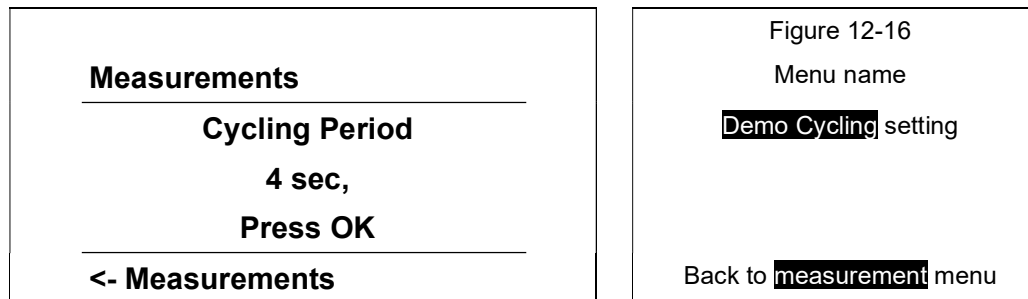

Figure 12-16 illustrates the **Demo Cycling** setting. The user presses the **OK** key to activate the **Demo Cycling** feature.



The **Demo Cycling** feature will then show various features of the **M2x3**, for example the **M253** Network Analyser will cycle through the following information:

- Meter identify
- Info page
- Memory status
- Quality report summary (current and last period)
- Graphical Voltage harmonic
- Alarm groups and status
- Voltage actual, maximum, and minimum values
- Current actual, maximum, and minimum values
- Energy values
- Cost management information
- MD values
- THD information

The user presses the **OK** key to deactivate the **Demo Cycling** feature.

### 11.3 Graphical Display

The graphical function activates a graphical display on the front of the **M2x3** that shows the instantaneous voltage and current waveform, either the RMS value or the harmonic content.

Figure 12-17 illustrates the **measurement** menu structure. The user can browse through the 7 available menus using the direction keys, by pressing either the DOWN ▼ or UP ▲ keys and then pressing the **OK** key to select the **Graphs time** or **Graphs FFT** setting.

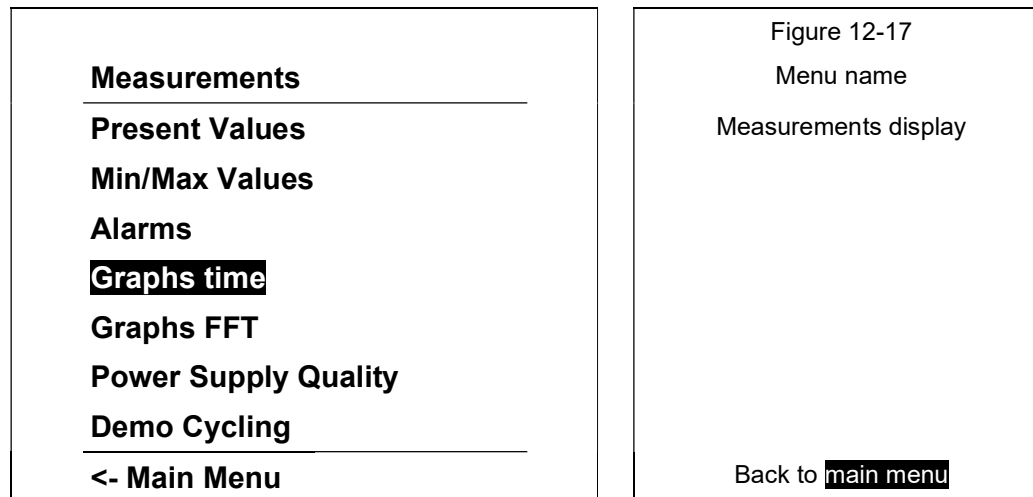
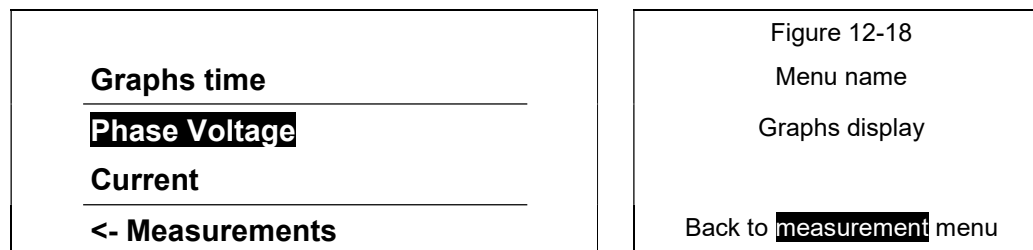

Figure 12-18 illustrates the **Graphs time** menu structure. The user can browse through the 7 available menus using the direction keys, by pressing the DOWN ▼ or UP ▲ keys and then pressing the OK key to select the **Graphs time** or **Graphs FFT** setting.



#### 11.4 Cost Energy Management

The first operation is to activate the tariff structure. Figure 12-19 shows the main menu, select the **settings** menu. From this menu scroll down to select the **Energy** Menu.

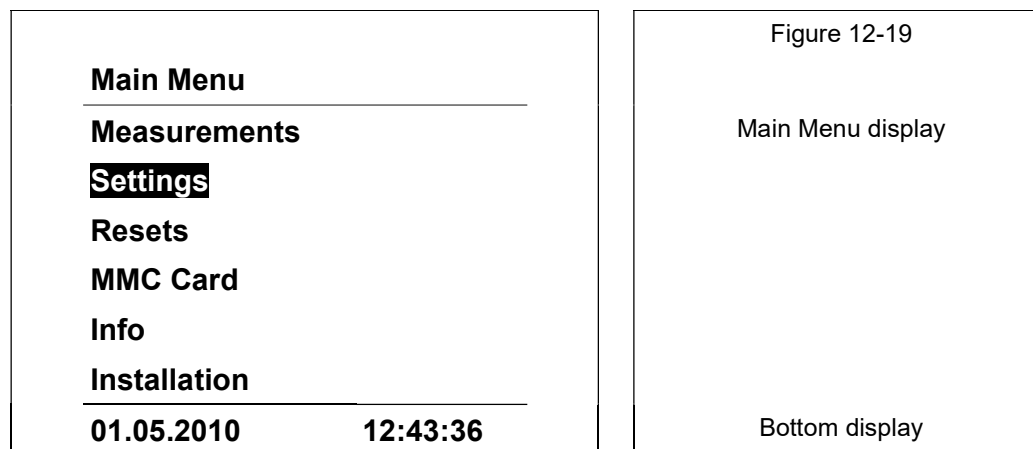

Figure 12-20 illustrates the **Energy menu** structure. The user can browse through the 2 available menus using the direction keys, by pressing the DOWN ▼ or UP ▲ keys and then pressing the OK key to select. The ◀ LEFT key is pressed to return to the **Settings** Menu.

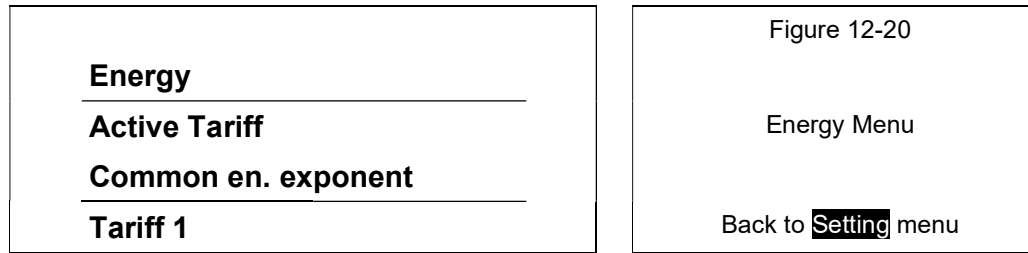

Figure 12-21 illustrates the **Active Tariff menu** structure. The user can browse through the 5 available menus using the direction keys, by pressing the DOWN ▼ or UP ▲ keys and then pressing the OK key to select. The ◀ LEFT key is pressed to return to the **Settings** Menu.

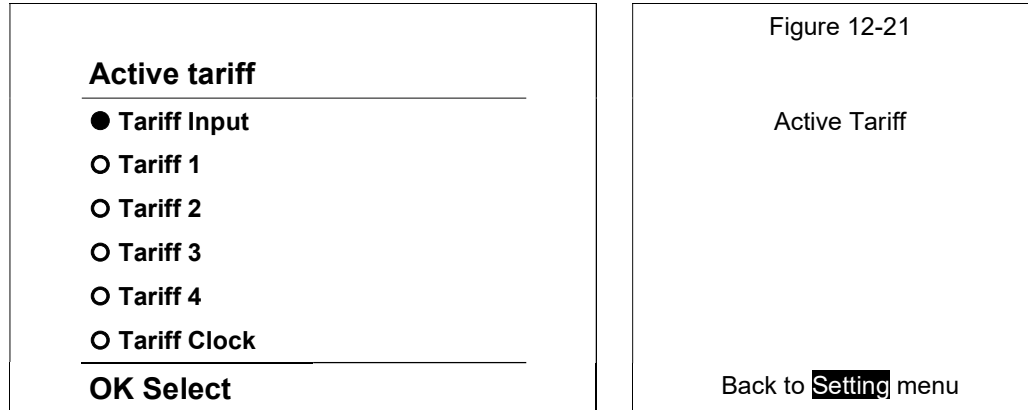
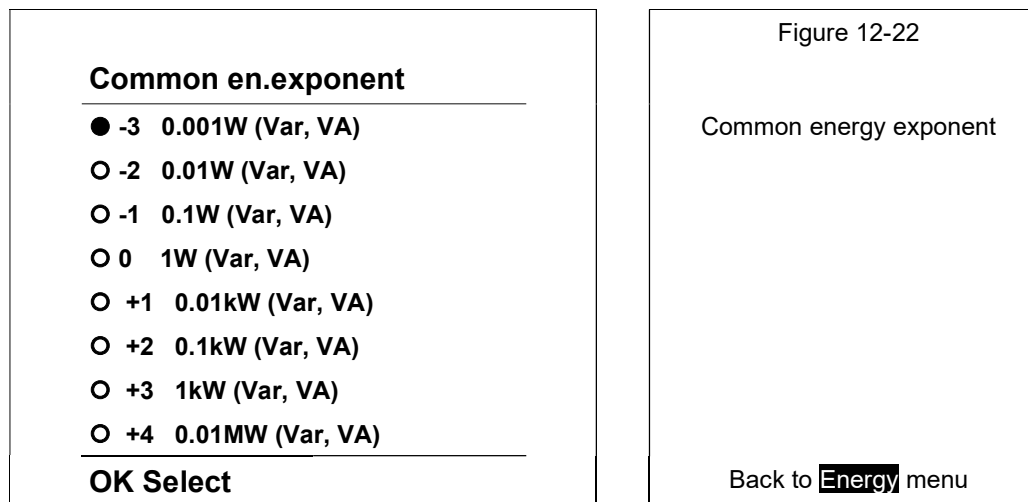

Figure 12-22 illustrates the **Common en.exponent menu** structure. The user can browse through the 5 available menus using the direction keys, by pressing the DOWN ▼ or UP ▲ keys and then pressing the OK key to select. The ◀ LEFT key is pressed to return to the **Energy** Menu.



The energy tariff structure can only be configured using QDSP.

## 11.5 Power Quality Recorder Report

The **M253** incorporates a power quality measurement function that monitors compliance to the European standard EN50160. To make the Power Quality settings and to extract the data and generate the reports the QDSP Professional software is required.

The power quality measurements can also be viewed using the **M2x3** display and keypad.

Figure 12-23 illustrates the **measurement** menu structure. The user can browse through the 7 available menus using the direction keys, by pressing the DOWN ▼ or UP ▲ keys and then pressing the OK key to select the **Power Supply Quality** Menu.

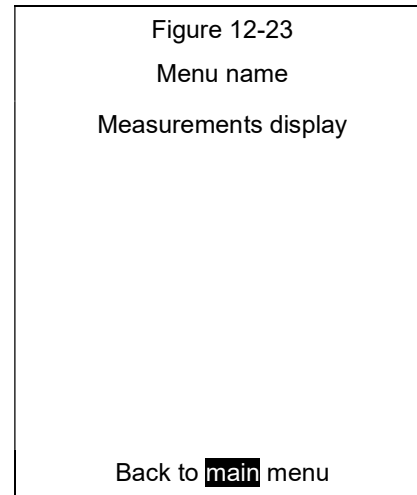
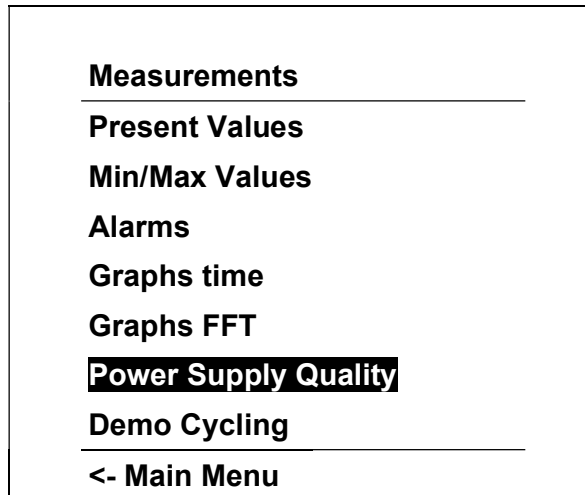

Figure 12-24 illustrates the **Power Supply Quality** Menu settings. The user selects a report on either the Actual (or current) and previous time periods. Press the **OK** key to select the required option.

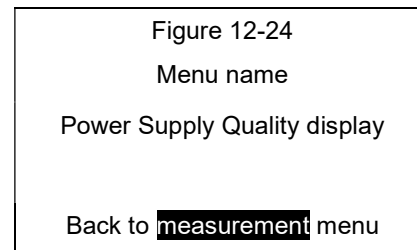
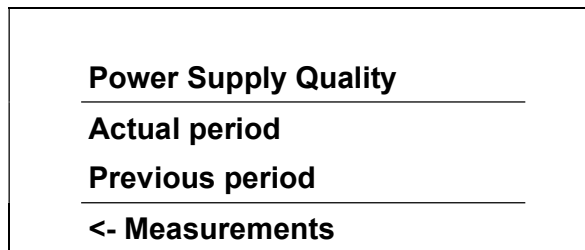

Figure 12-25 illustrates page 1 of 4 from **Actual Period** report. The **Previous period** report uses the same format as this and the next illustrations. The user moves through the report information using the **>** RIGHT or **<** LEFT keys. Press the **OK** key to return to the **Power Supply Quality** Menu.

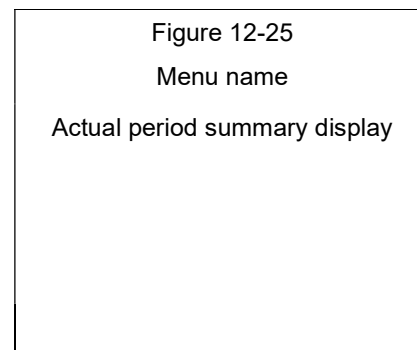
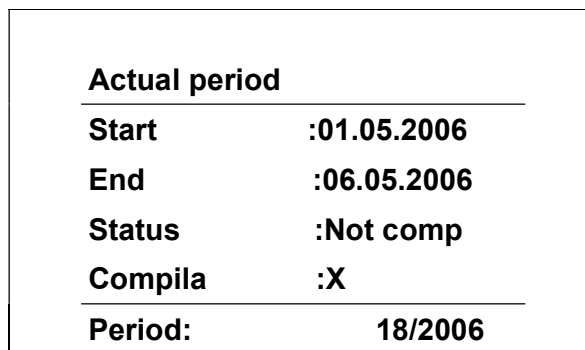

Figure 12-26 illustrates page 2 of 4 from **Actual Period** report. The user moves through the report information using the **>** RIGHT or **<** LEFT keys. Press the **OK** key to return to the **Power Supply Quality** Menu.

<b>Actual period</b>	
<b>Frequency 1</b>	: X
<b>Frequency 2</b>	: X
<b>Unbalance</b>	: X
<b>Voltage 1</b>	: ✓
<b>Voltage 2</b>	: X
<b>Period:</b>	<b>18/2006</b>

<b>Figure 12-26</b>	
Menu name	
Actual period summary display	

Figure 12-27 illustrates page 3 of 4 from **Actual Period** report. The user moves through the report information using the ► RIGHT or ◀ LEFT keys. Press the **OK** key to return to the **Power Supply Quality** Menu.

<b>Actual period</b>	
<b>THD</b>	: ✓
<b>Harmonics</b>	: X
<b>Short flicker</b>	: ✓
<b>Long flicker</b>	: X
<b>Transients</b>	: X
<b>Period:</b>	<b>18/2006</b>

<b>Figure 12-27</b>	
Menu name	
Actual period summary display	

Figure 12-28 illustrates page 4 of 4 from **Actual Period** report. The user moves through the report information using the ► RIGHT or ◀ LEFT keys. Press the **OK** key to return to the **Power Supply Quality** Menu.

<b>Actual period</b>	
<b>Overvoltage</b>	: ✓
<b>Dips</b>	: X
<b>Short inter.</b>	: ✓
<b>Long inter</b>	: X
<b>Period:</b>	<b>18/2006</b>

<b>Figure 12-28</b>	
Menu name	
Actual period summary display	

## 12. M2X3 SETTINGS USING KEYPAD/DISPLAY

**M2x3** settings can be remotely modified using the QDSP software, or with the use of the keypad on the **M2x3**.

All settings in the **M2x3** can be modified using the QDSP software, but only the basic settings can be programmed using the keypad and display. See section 14 for full details.

The Installation Wizard described in 12.1 is designed to take the user through the minimum functions necessary to install the **M2x3**; the following functions can be set:

Language

Date & Time

Connection Mode: VT Primary: VT Secondary: CT Primary: CT Secondary

Device Address: Baud Rate: Parity: Stop Bit

All these functions can be set individually from the settings menu. Each setting is described in the following sections.

### 12.1 Setting Navigation

Figure 13-1 illustrates the **Settings menu** structure. The user can browse through the 6 available menus using the direction keys, by pressing the DOWN ▼ or UP ▲ keys and then pressing the **OK** key to select. The ◀ LEFT key is pressed to return to the **Main Menu**

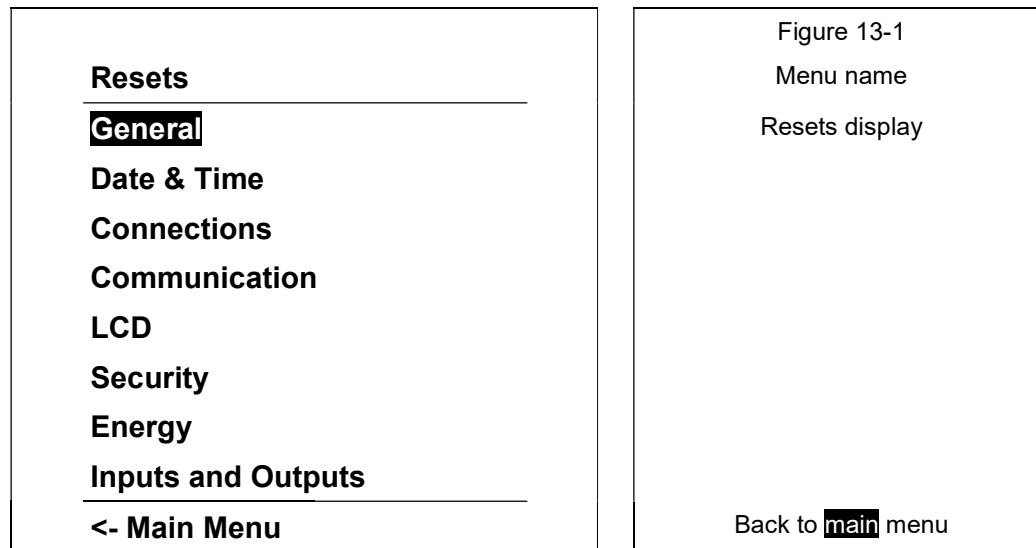

### 12.2 General Navigation

Figure 13-2 illustrates the **General menu** structure. The user can browse through the 7 available menus using the direction keys, by pressing the DOWN ▼ or UP ▲ keys and then pressing the **OK** key to select. The ◀ LEFT key is pressed to return to the **Settings Menu**

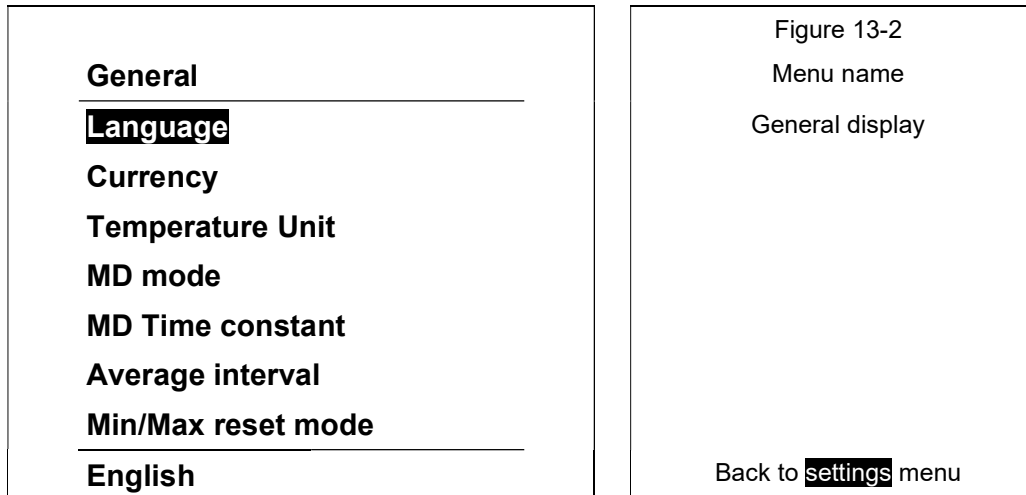

Figure 12-1 in the Installation Wizard section describes the language selection. Once selected, the language option appears in the lower menu when the cursor highlights the language option.

Figure 13-3 illustrates the **Currency** setting. The user can enter the 3 characters of to describe the unit of currency that they require. This is used with the Energy cost management application. Pressing the DOWN ▼ or UP ▲ keys scrolls through the alphabet. The ► RIGHT or ◀ LEFT keys are used to move the cursor. Press the **OK** key to return to the **General Menu**

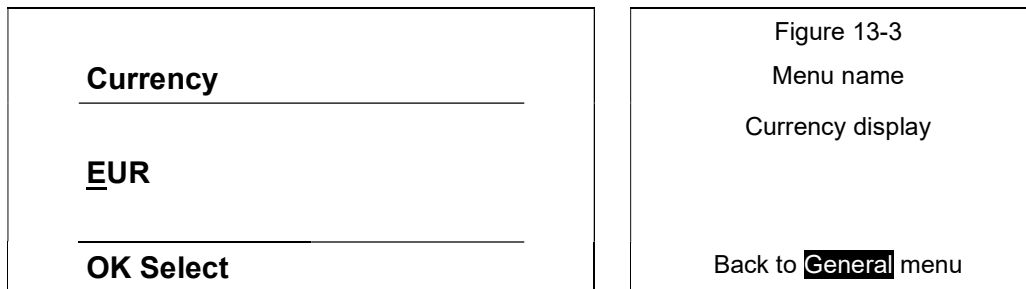

Figure 13-4 illustrates the **Temperature Unit** setting. The user can select either Centigrade or Fahrenheit as the unit of measure. Press the **OK** key to return to the **General Menu**

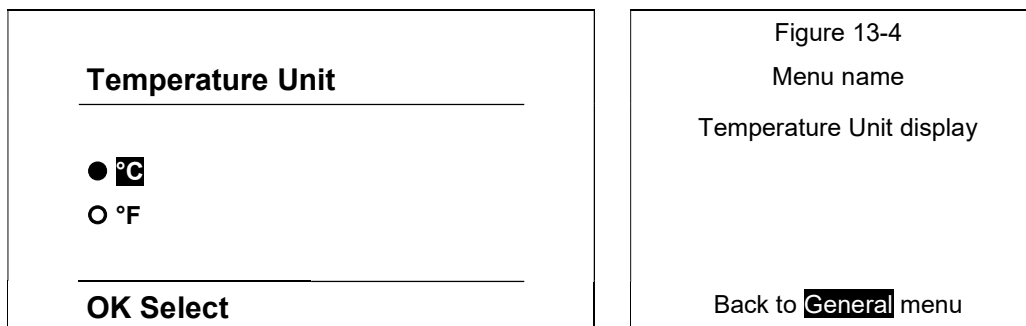

Figure 13-5 illustrates the **MD Mode** setting. The user can select from 6 different methods of calculating MD or Maximum Demand. Pressing the DOWN ▼ or UP ▲ keys scrolls through the options. Press the **OK** key to return to the **General Menu**

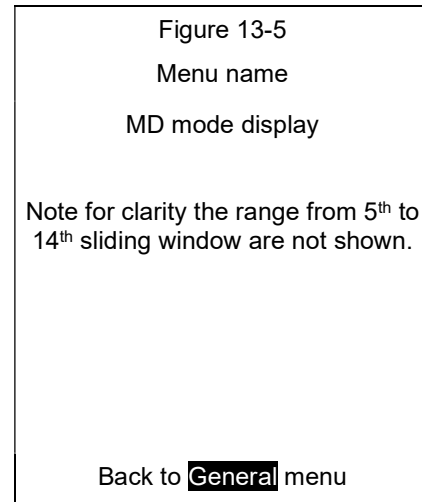
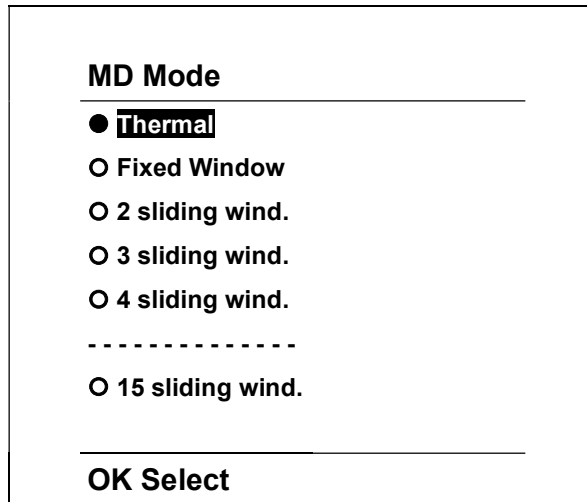

Figure 13-6 illustrates the **MD time constant** setting. The user can select a time constant setting from 1 minute up to 255 minutes. Pressing the DOWN ▼ or UP ▲ keys scrolls through the options. Press the **OK** key to return to the **General Menu**

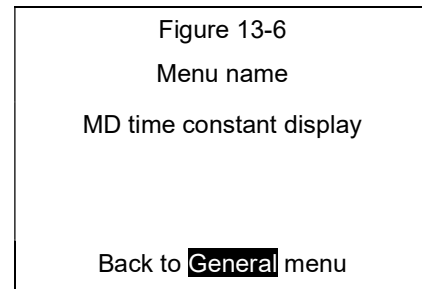
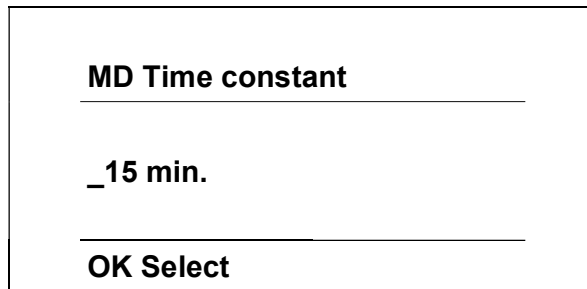

Figure 13-7 illustrates the **Average Interval** setting. The user can select from 6 different settings, from 8 periods to 256 periods. Pressing the DOWN ▼ or UP ▲ keys scrolls through the options. Press the **OK** key to return to the **General Menu**

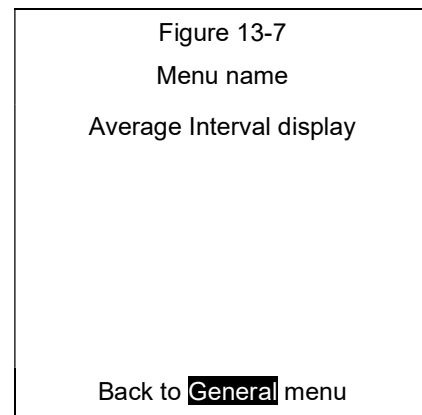
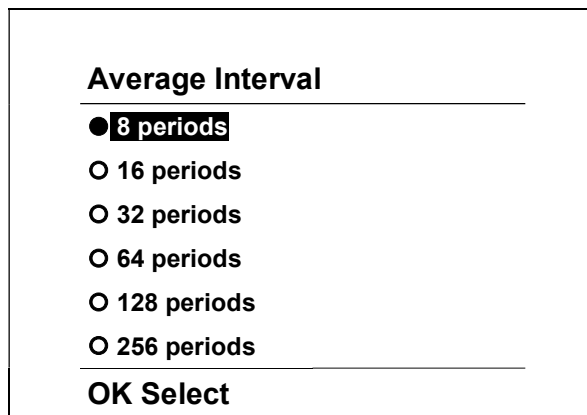
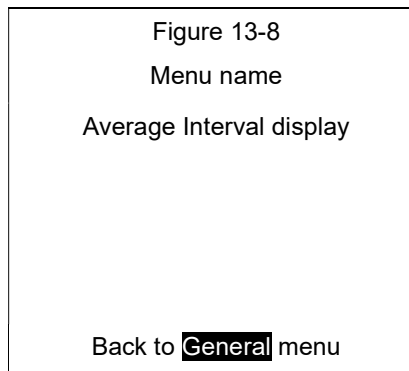
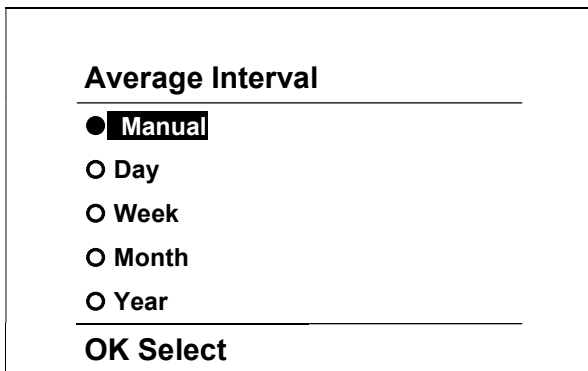

Figure 13-8 illustrates the **Min/Max reset mode** setting. The user can select from 5 different settings, manual, day, week, month, and year. Pressing the DOWN ▼ or UP ▲ keys scrolls through the options. Press the **OK** key to return to the **General Menu**



**12.3 Date and Time Navigation**

Figure 13-9 illustrates the **Date & Time menu** structure. The user can browse through the 4 available menus using the direction keys, by pressing the DOWN ▼ or UP ▲ keys and then pressing the **OK** key to select. The ◀ LEFT key is pressed to return to the **General Menu**

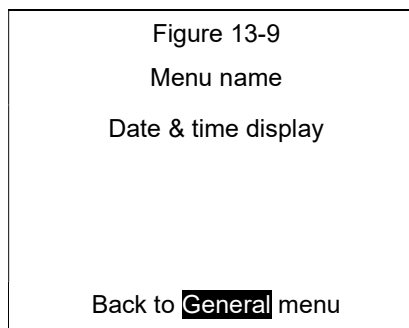
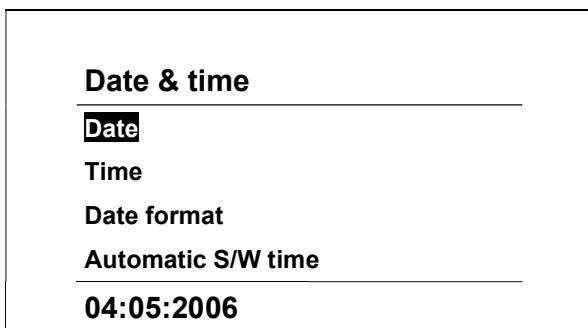

Figure 12-2 in the Installation Wizard section describes date setting. This is shown in the lower menu when the cursor highlights the Date option.

Figure 12-3 in the Installation Wizard section describes time setting. This is shown in the lower menu when the cursor highlights the time option.

Figure 13-10 illustrates the **Date format** setting. The user can select from 2 options: Day:Month:Year or Month:Day:Year, by pressing the DOWN ▼ or UP ▲ keys and then pressing the **OK** key to select. The ◀ LEFT key is pressed to return to the **General Menu**

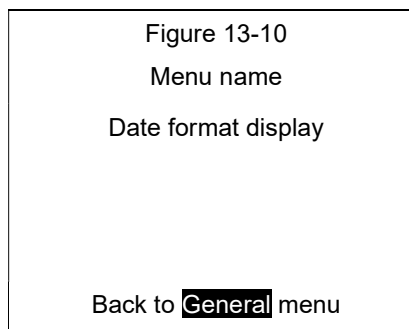
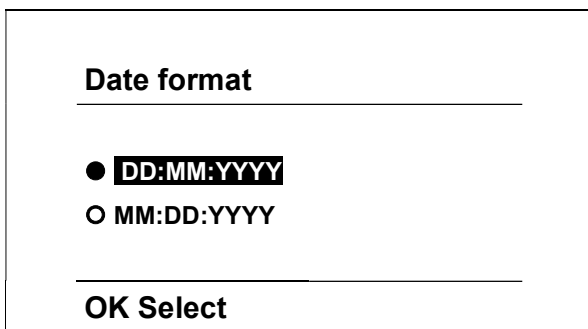
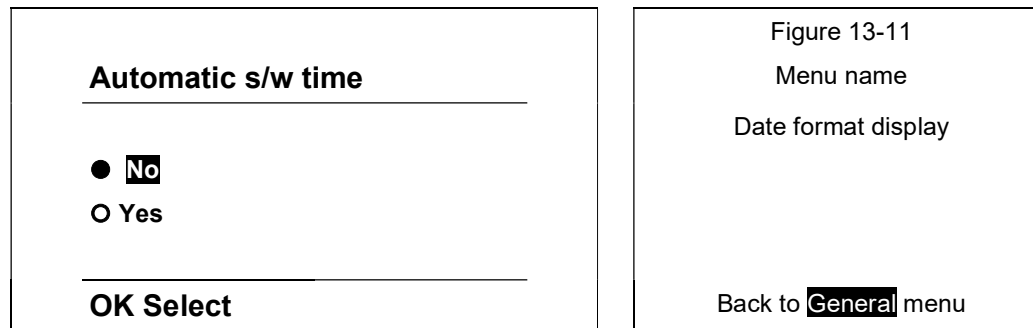
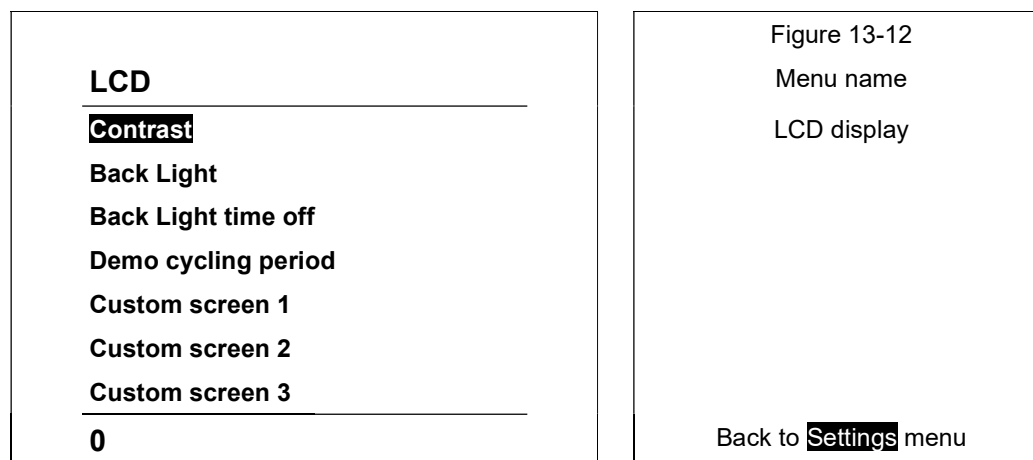

Figure 13-11 illustrates the **Automatic s/w time** setting. The user can activate the automatic summer/wintertime setting. This is used with the Energy cost management application. Press the DOWN ▼ or UP ▲ keys to select and press **OK** confirm selection. The ◀ LEFT key is pressed to return to the **General Menu**



## 12.4 LCD Navigation

Figure 13-12 illustrates the **LCD menu** structure. The user can browse through the 7 available settings using the direction keys, by pressing the DOWN ▼ or UP ▲ keys and then pressing the **OK** key to select. The ◀ LEFT key is pressed to return to the **Settings Menu**



**Contrast:** this is adjusted using the DOWN ▼ or UP ▲ keys until the desired contrast has been reached, the scale is from -10 to +10 with 0 being the normal value. Pressing the **OK** key confirms the selection. The numeric value is shown in the lower menu when the **Contrast** setting is selected.

**Back Light:** this is adjusted using the DOWN ▼ or UP ▲ keys until the desired lighting has been reached, the scale is from 1 to +10. Pressing the **OK** key confirms the selection. The numeric value is shown in the lower menu when the **Back Light** setting is selected.

**Back Light time off:** this is adjusted using the DOWN ▼ or UP ▲ keys until the desired time off setting has been reached. The setting is from 0 to 60 minutes. Pressing the **OK** key confirms the selection. The numeric value is shown in the lower menu when the **Back Light time off** setting is selected.

**Demo cycling period:** this is adjusted using the DOWN ▼ or UP ▲ keys until the desired time period has been reached. The setting is from 1 to 60 seconds. Pressing the **OK** key confirms the selection. The numeric value is shown in the lower menu when the **Demo Cycling period** setting is selected.

Figure 13-13 illustrates the **Custom screen menu** structure. The user can browse customise 3 screens to show important information. The desired measurement is selected using the DOWN ▼ or UP ▲ keys and then pressing the **OK** key to confirm. The RIGHT ► or LEFT ◀ keys are used to move the cursor to the next measurement. Pressing the **OK** key confirms the selection and returns to the **LCD Menu**

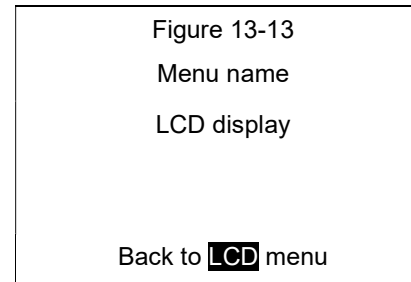
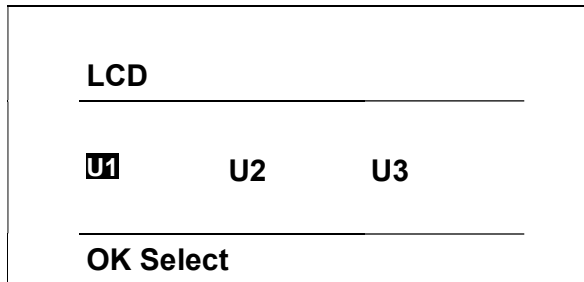

## 12.5 Security Navigation

Figure 13-14 illustrates the **Security menu** structure. The user can browse through the 5 available settings using the direction keys, by pressing the DOWN ▼ or UP ▲ keys and then pressing the OK key to select. The ◀ LEFT key is pressed to return to the **Settings Menu**.

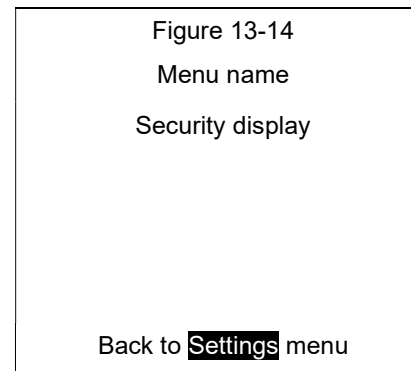
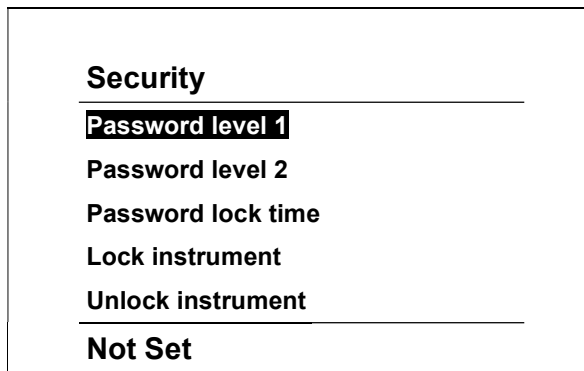
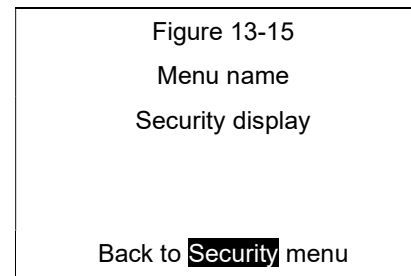
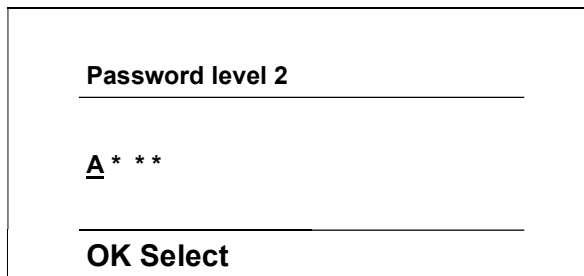

Figure 13-15 illustrates the **Password level 2** setting. The user can change the password, which is 4 characters long, by pressing the DOWN ▼ or UP ▲ keys and then pressing the OK key to select. The ◀ LEFT key is pressed to return to the **Security Menu**. Password level 1 has the same structure.



There are 3 levels of security:

L0 - no password required so the user can view and change any of the M2x3 settings.

L1 - level 1 password: the user can only change the following settings: Date format, Date and Time setting, Automatic summer/wintertime on/off setting, reset all the maximum demand measurements, synchronise maximum demand on/off setting, and alarm relays on/off setting.

L2 - level 2 password: the user cannot change any of the settings without a password.

If the password is lost or forgotten, ask GE Vernova Grid Solutions technical support for the factory allocated password and provide the serial number of the **M2x3** instrument.

**Password lock time:** this is adjusted using the DOWN ▼ or UP ▲ keys until the desired lock time setting has been reached. The setting is from 0 to 60 minutes. Pressing the OK key confirms the selection. The numeric value is shown in the lower menu when the **Password Lock time** setting is selected.

**Lock instrument:** by entering the password the security is activated. This is adjusted using the DOWN ▼ or UP ▲ keys until each desired character is displayed, then RIGHT ► or LEFT ◀ keys for each position. Pressing the **OK** key confirms the selection. The **Enabled Level ?** will appear in the lower menu when the **Lock instrument** or **unlock instrument** setting is selected.

**12.6 Inputs and Outputs**

Figure 13-16 illustrates the **Settings menu** structure. To select the Input/Output options the user presses the DOWN ▼ or UP ▲ keys and then pressing the **OK** key to select **Inputs and Outputs**. The ◀ LEFT key is pressed to return to the **Main Menu**.

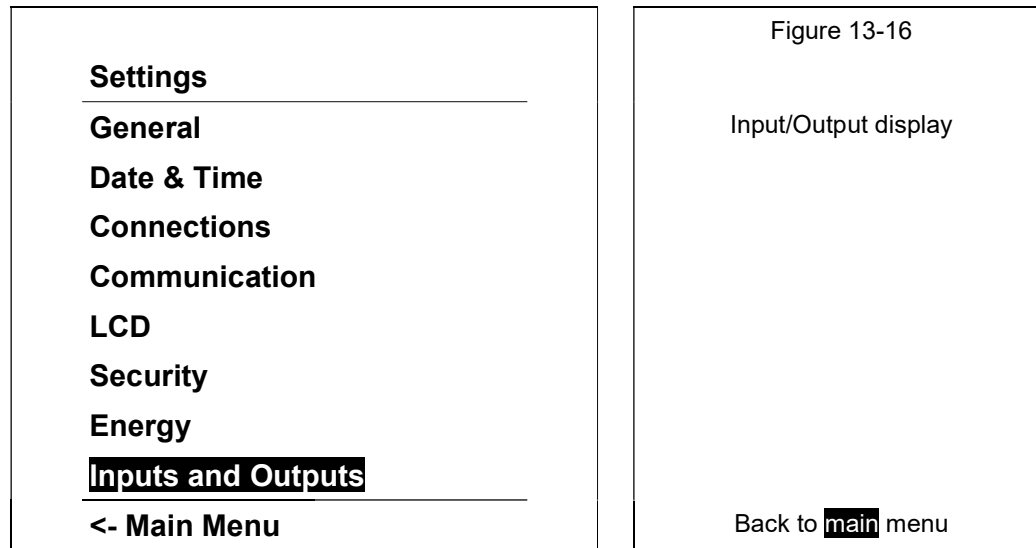

Figure 13-17 illustrates the **I/O menu** structure. To select the Input/Output options the user presses the DOWN ▼ or UP ▲ keys and then pressing the **OK** key to select. The bottom menu indicates what type of I/O is fitted in each of the four modules. The ◀ LEFT key is pressed to return to the **Setting Menu**.

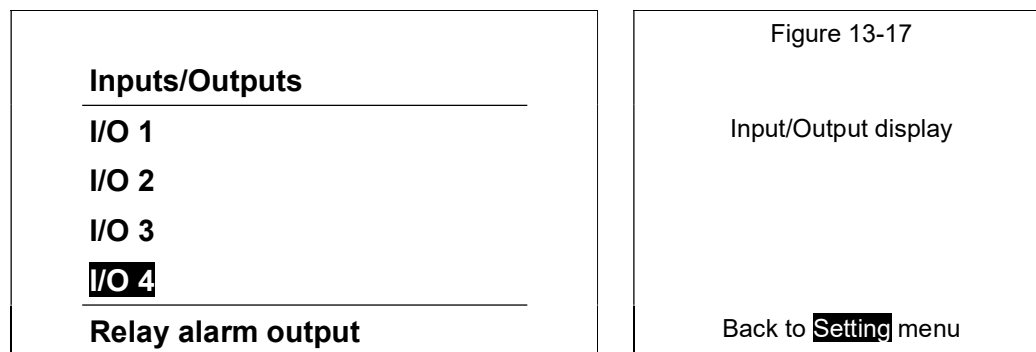
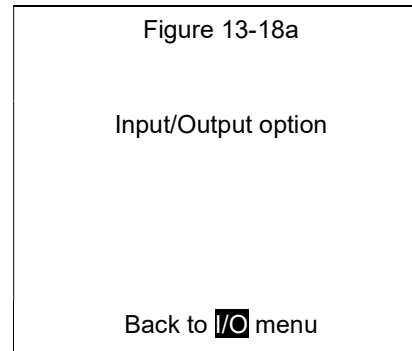
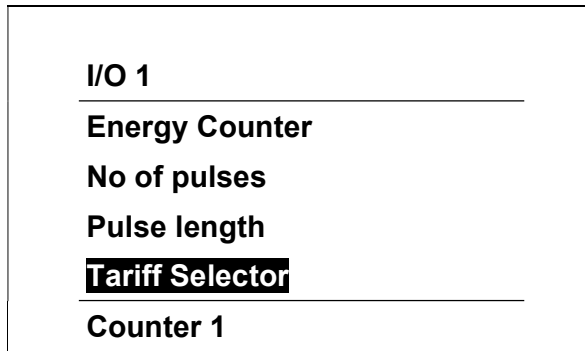
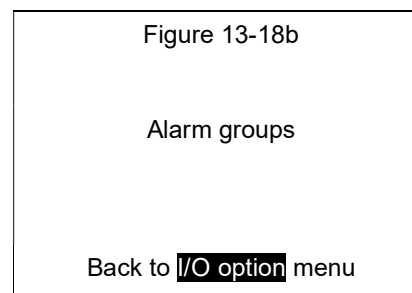
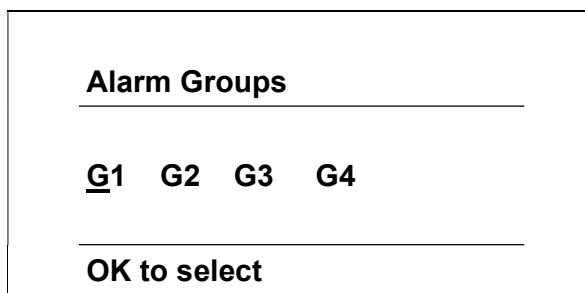

Figure 13-18a illustrates the **I/O option** structure. To select the Input/Output options the user presses the DOWN ▼ or UP ▲ keys and then pressing the **OK** key to select. The bottom menu indicates what type of I/O is fitted. The ◀ LEFT key is pressed to return to the **I/O Menu**.



The Energy counter is fully configured by setting the energy counter:

This maps which energy counter is used for each pulsed contact and whether the alarm is enabled. When the alarm function is enabled the options for alarm groups and an output signal appear on the menu structure. The alarm group menu is shown in Figure13-18b.



This output signal has several options as shown in Figure 13-18c, press the DOWN ▼ or UP ▲ keys to move between options and then pressing the **OK** key to select.

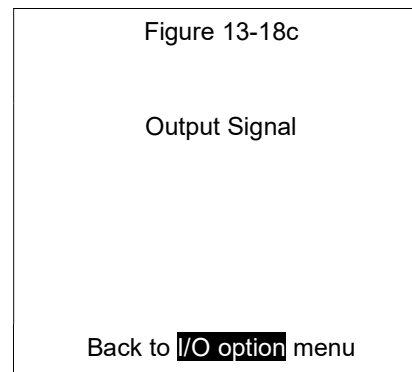
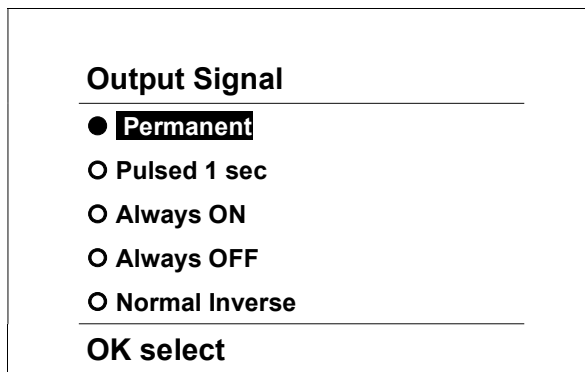

The analogue output is configured using the QDSP setting software see section 14.

---

## 13. M2X3 SETTINGS USING QDSP SOFTWARE

### 13.1 Introduction

**M2x3** settings can be remotely modified using the QDSP software, when connected to a PC, or with the use of the keypad on the **M2x3**.

All settings in the **M2x3** can be modified using the QDSP software, but only the basic settings can be programmed using the keypad and display. The settings that can be modified using the **M2x3** keypad are indicated by (KD) in the sections below.

### 13.2 QDSP Software

QDSP is a software tool for complete monitoring of measuring instruments, connected to a PC via serial, USB, or TCP/IP communication. A user-friendly interface consists of five segments: devices management, instrument settings, real-time measurements, data analysis and software upgrading.

A separate QDSP manual is available that defines the operation of QDSP in detail.

#### 13.2.1 Devices management

The communications parameters for any connected device can be modified. Also included are browsers which scan the communications networks attached to the PC and identify all the devices connected with their addresses and communications parameters. This can be done on RS232, RS485, USB and Ethernet connections.

#### 13.2.2 Instrument settings

The instrument settings are organized in a tree structure, and they can be modified simply as required. In addition to transferring settings to the instrument, QDSP can also store the data to settings files and read it back when required.

#### 13.2.3 Real time measurements

All measurements can be displayed in real time in a table or graphically. Harmonics and their time-reconstruct signals are displayed graphically.

If further processing of the measurement data is required, it can be copied via a clipboard and inserted into standard Windows formats.

#### 13.2.4 Data analysis

Analysis can be performed on the recorded data in the **M243** and **M253**. Recorded values can be displayed in a tabular or graphical form. The events that triggered alarms can be analysed or a report on supply voltage quality can be made. All data can be exported to an Access database, Excel worksheet or a text file.

#### 13.2.5 Software upgrading

It is suggested that the latest version of QDSP should always be used and if the system is also connected to the internet it will define if an upgrade is available for download.

### 13.3 Setting Procedure

To modify the settings with QDSP the current parameters must be loaded first. Instrument settings can be acquired via a communications link, or they can be loaded off-line from a file on a local disk. The QDSP contains sample settings files for each product variant that can be downloaded to show the range of settings available for the specific product. These files can be modified and then stored under a different name allowing an instrument configuration to be generated off-line without an instrument attached and downloaded later.

Settings are displayed in the QDSP setting window, the left part displays a hierarchical tree structure of settings, the right hand part displays parameter values of the chosen setting group, see Figure 14-1.

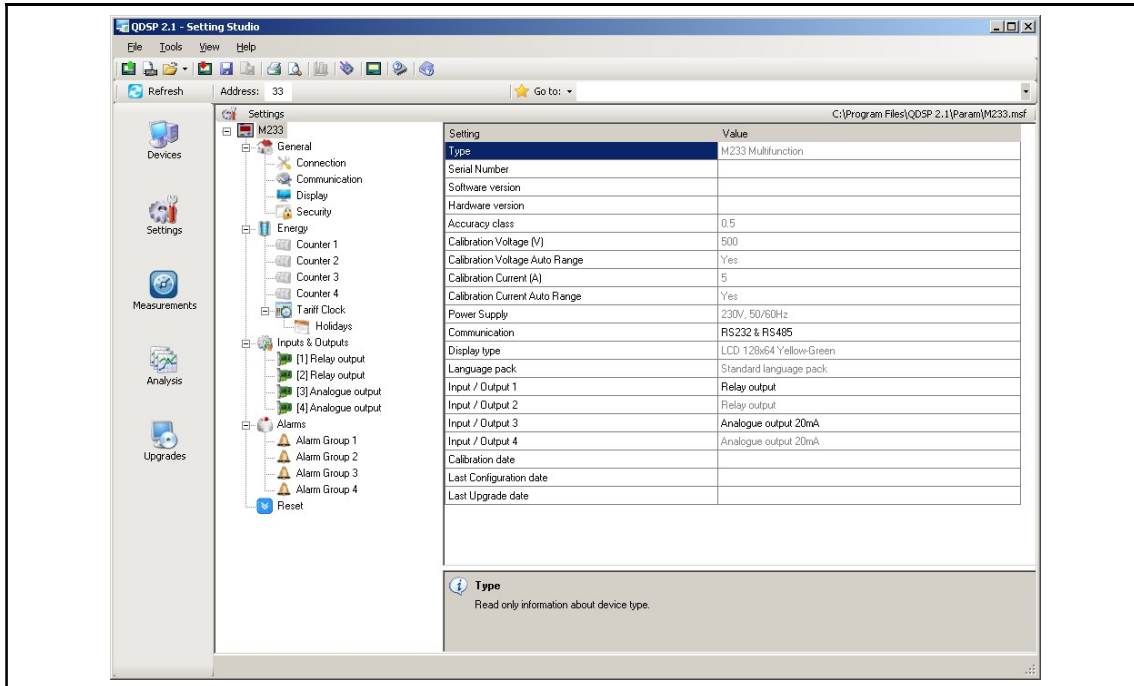

FIGURE 14-1: QDSP INTERFACE

**13.4 General Settings**

General Settings are essential for the operation of the **M2x3**. They are divided into three additional sublevels (Connection, Communication, and Security).

**13.4.1 Description and location**

These are two parameters that are extended for easier recognition of a particular instrument. They allow for the identification or location to be defined where measurements are performed.

**13.4.2 Average interval**

The averaging interval defines the refresh rate of measurements for communications and **M2x3** display.

**13.4.3 Currency (KD)**

Define currency for evaluating energy costs. A currency designation consists of up to 4 letters taken from the English or Russian alphabet and numbers and symbols stated in the table below.

English	A	B	C	D	E	F	G	H	I	J	K	L	M	N	O	P	Q	R	S	T	U	V	W	X	Y	Z
	a	b	c	d	e	f	g	h	i	j	k	l	m	n	o	p	q	r	s	t	u	v	w	x	y	z
Symbols		!	"	#	\$	%	&	'	(	)	*	+	,	-	.	/	0 to 9	:	;	<	=	>	?	@		
Russian	А	Б	В	Г	Д	Е	Ж	З	И	Й	К	Л	М	Н	О	П	Р	С	Т	У	Ф	Х	Ц	Ч	Ш	Щ
	а	б	в	г	д	е	ж	з	и	й	к	л	м	н	о	п	р	с	т	у	ф	х	ц	ч	ш	щ

**13.4.4 Temperature unit (KD)**

Choose temperature units for display °C or °F.

**13.4.5 Date format (KD)**

Set a date format.

**13.4.6 Date and time (KD)**

Set the date and time of the meter, Setting is important for correct data storage operation, maximum values (MD), etc.

#### 13.4.7 Auto summer/wintertime (KD)

If selected, the time will automatically shift to Winter or Summer time when required.

#### 13.4.8 Maximum demand calculation (MD mode) (KD)

The **M2x3** provides maximum demand values from several different demand values.

- Thermal Function
- Fixed Window
- Sliding Windows (up to 15)

See section 9.4 for details.

#### 13.4.9 Resetting min/max (KD)

Defines how and when the stored Min/Max values will be reset.

The reset can either be Manual or in Automatic mode (daily, weekly, monthly, or yearly reset)

In Automatic mode the resets are performed at the beginning of the defined period at midnight.

- Daily - every day at 00:00
- Weekly - every Monday at 00:00
- Monthly - the first day of the month at 00:00
- Yearly - the first day of the year (1<sup>st</sup> January) at 00:00

#### 13.4.10 Starting current for PF and PA (mA)

At all measuring inputs noise is usually present. It usually has consistent amplitude and its influence on the accuracy of the measurement increases as the amplitude of the signal to be measured decreases. It is also present when measuring signals are not connected and can give false readings for all subsequent calculations.

By setting a starting current for Total Power Factor and Power Angle, a minimum level is defined where the measurements and calculations commence, reducing the effect of any input noise.

#### 13.4.11 Starting current for all powers (mA)

By setting a Minimum Starting Current, a level is defined where the measurements of Current and calculation of all powers commence, reducing the effect of any input noise.

#### 13.4.12 Calculation of harmonics

The selection of the reference for the calculation of harmonics is important for the calculation of the absolute values. It is possible to select harmonics:

- As a percentage of the RMS signal value where a value is calculated for all harmonics
- Or relative to the fundamental (first harmonic) where all other harmonics are calculated relative to the 1<sup>st</sup> harmonic.

#### 13.4.13 Reactive power calculation

Two different principles of reactive power and energy calculation are used:

**Standard method:**

With this method a reactive power and energy are calculated based on assumption that all power (energy) that is not active is reactive.

$$Q^2 = S^2 - P^2$$

This means also that all higher harmonics will be measured as reactive power (energy).

**Delayed current method:**

With this method, reactive power (energy) is calculated by multiplication of voltage samples and delayed current samples.

$$Q = U \times I_{+90^\circ}$$

With this method, reactive power (energy) represents only true reactive component of apparent power (energy).

**13.5 Connection**

The setting of the connection parameters must reflect the actual applications, or the measurements will not be valid.

All the settings in this section should be defined before the settings for the analogue and alarm outputs, as changes to this section may automatically change the measurements and output settings.

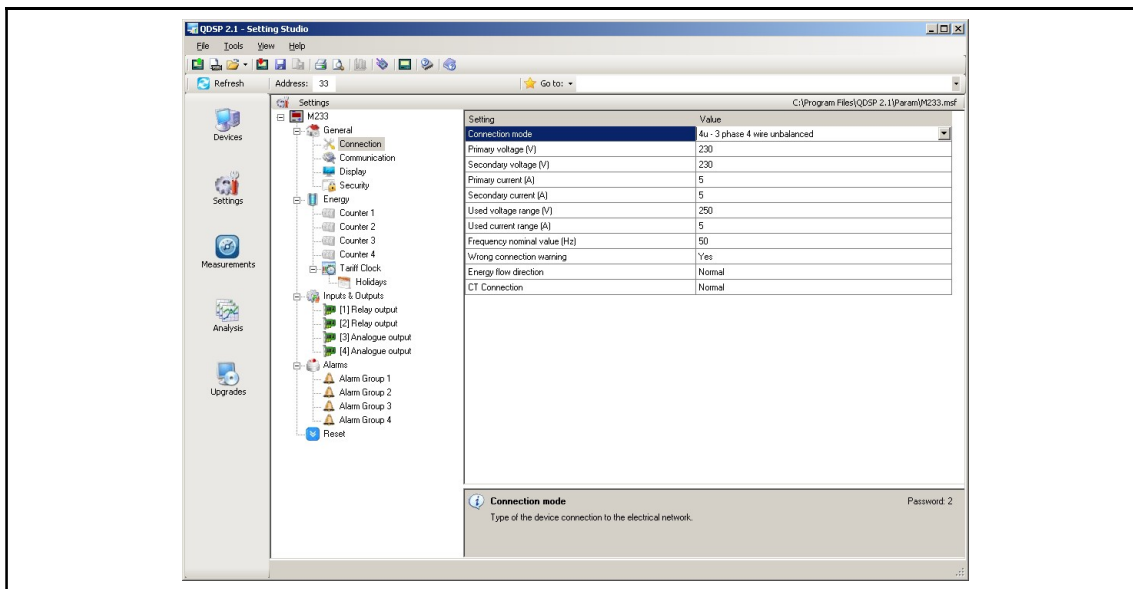

FIGURE 14-2: CONNECTION

**13.5.1 Connection (KD)**

When the connection is selected, the load connection and the supported measurements are defined (see section 8).

When the Connection is modified all other settings must be reviewed to ensure that they are still valid for the new Connection selected.

**13.5.2 Setting of current and voltage ratios (KD)**

The details of the application must be known to define these settings; all other measurements depend on them. Values with up to 5 numerical digits and a maximum of 3 decimal places can be input.

Settings range	VT primary	VT secondary	CT primary	CT secondary
Maximum value	1638,3 kV	13383 V	1638,3 kA	13383 A
Minimum value	0,1 V	1 mV	0,1 A	1 mA

**13.5.3 Used voltage and current range**

The setting of this range relates to the setting of all alarms, analogue outputs, and the display (calculation) of energy and measurement recording. Using a value that matches the expected measurement range (with overload) will achieve the highest quality of measurements.

If the 'Used' ranges are changed after the analogue or alarm settings have been defined, then the analogue and alarm settings will be modified automatically, as defined below. It may be necessary to modify the settings for the analogue and alarm outputs.

The 'Used' ranges are used to set the default scaling for the analogue output, which can be subsequently changed to meet the application requirements. Internally the analogue settings are also stored as a percentage of the 'Used' ranges. If the 'Used' ranges are subsequently changed the analogue output settings will be correspondingly changed to maintain the settings as the same percentage of the 'Used' range.

Although the alarm settings are defined in real values on QDSP, the alarms are also calculated as a percentage of the 'Used' range. If the 'Used' ranges are subsequently changed the alarm settings will be correspondingly changed to maintain the settings as the same percentage of the 'Used' range.

#### 13.5.4 Nominal frequency

A valid frequency measurement is within  $\pm 32\text{Hz}$  of the nominal frequency. This setting is only used for alarms and recorders.

### 13.6 Communication

The settings displayed depend on the hardware options on the specific instrument connected or the settings in the specific settings file that is being worked on off-line.

#### 13.6.1 Serial communication parameters (COM1) (KD)

These parameters are important for the correct operation in RS485 networks or connections with PC via RS232 communications. Factory settings for communication are #33\19200 (or 115200),n,8,2 (address 1 to 247\data rate 2400 to 115200 b/s, parity, data bits, stop bit).

#### 13.6.2 Ethernet communication

##### 13.6.2.1 Device address (KD)

The device address should be maintained at the default value of 33.

##### 13.6.2.2 IP address (KD)

The communication interface should have a unique IP address in the Ethernet network. Two modes for assigning IP are described:

- **Fixed IP address:** In most installations a fixed IP address is required. A system provider usually defines IP addresses. An IP address should be within a valid IP range, unique for your network and in the same sub-network as your PC.
- **DHCP:** An automatic method of assigning IP addresses (DHCP) is used in most networks. If you are not sure if DHCP is used on your network, check it with your system provider.

##### 13.6.2.3 Local port (KD)

Use a non-reserved port number from 1025 to 65535. Do not set the Local Port to any of the reserved port numbers.

If using Redirector software, the port number should be between 14000 and 14009.

Port numbers	Function
1 – 1024, 9999, 30718, 33333	Reserved numbers
14000 – 14009	Reserved for Redirector

Factory settings for Ethernet Communications are:

IP Address	DHCP (automatically)
TCP Port	10001
Subnet Mask	255.255.255.0

### 13.6.3 USB

The **M2x3** will be identified as a USB device when connected to a USB port on the PC, refer to the separate **QDSP** manual for details of the driver installation.

## 13.7 Security

Parameter settings are divided into 2 groups for regarding security level:

1. If the passwords are set to 'AAAA' (default) there is no restriction to the access of parameter settings.
2. At the first level (PL1), the settings for the real time clock and the reset of the energy registers and MD can be accessed.
3. At the second level (PL2), access is given to all parameter settings.
4. Change to the language setting is possible without inputting a password. When language is changed to or from Russian, character transformation has to be taken in to account, see section 14.4.3.
5. A Backup password (BP) is used if the passwords at level 1 (PL1) and level2 (PL2) have been forgotten, and it is different for each device depending on the serial number of the instrument. The BP password is available from GE Vernova Grid Solutions technical support, and is entered instead of password PL1 and/or PL2. The serial number is stated on the product label or can be read with QDSP and must be supplied when requesting the BP.

### 13.7.1 Password setting (KD)

A password consists of four capital letters taken from the British alphabet from A to Z. When setting a password, only the letter being set is visible, while the others are covered with an asterisk.

Two passwords (PL1, PL2) and the time after which they become active, can be set.

### 13.7.2 Password modification (KD)

A password can be modified; however, only the password whose access has been unlocked (password entered) can be modified.

To disable a password previously set, modify the password back to 'AAAA'.

## 13.8 Energy

The parameters defining the energy measurement and totalising can be modified. After modifications have been done the energy meters must be reset or all subsequent energy measurements will be incorrect.

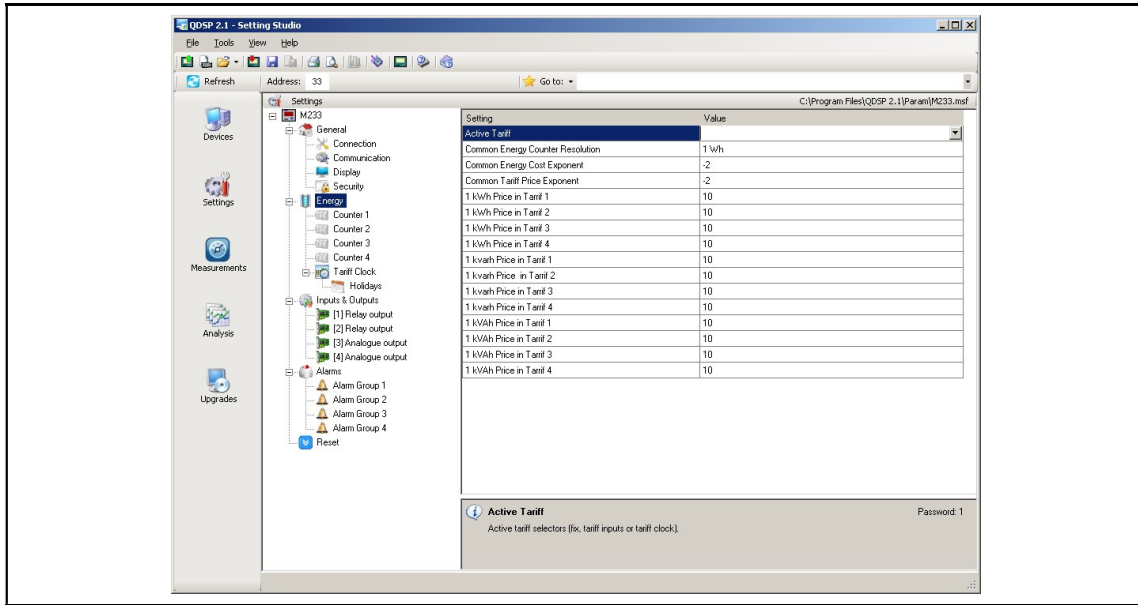

FIGURE 14-3: ENERGY

13.8.1 Active tariff (KD)

When active tariff is set, one of the tariffs is defined as active, switching between tariffs is done with a tariff clock or a tariff input. For the operation of the tariff clock other parameters of the tariff clock that are accessible only via the communications must be set correctly.

13.8.2 Common energy exponent

The Common energy exponent defines the minimum energy value that can be displayed on the energy counter. Based on this and a counter divider, a basic calculation factor for energy is defined (-3 is  $10^{-3}\text{Wh}=\text{mWh}$ , 4 is  $10^4\text{Wh} = 10 \text{ kWh}$ ). The Common energy exponent also affects the setting of pulse outputs and alarm outputs when the instrument is being used as an energy meter.

The Table below defines recommended values for the Common Energy exponent, where the counter divider is at its default value of 10.

Current Voltage	1 A	5 A	50 A	100 A	1000 A
110 V	-1	0	1	1	2
230 V	0	0	1	2	3
1000 V	0	1	2	3	4
30 kV	2	2	3	4	4*

\* - Counter divider should be at least 100

13.8.3 Common exponent of energy cost

Defines the number of decimal places used for the energy cost calculation and storage. The cost exponent is used for recording the cost without decimal places.

13.8.4 Common exponent of tariff price and energy price in tariffs

The exponent and price represent the energy price (active, reactive, common) in a tariff. The price exponent is used for recording the price without decimal places.

13.8.5 Measured energy

Each counter is enabled or disabled and can be configured to read any energy value from a drop down selection. The Energy counters can operate in all four quadrants; this is chosen using a graphical interface as shown in Figure 14-4.

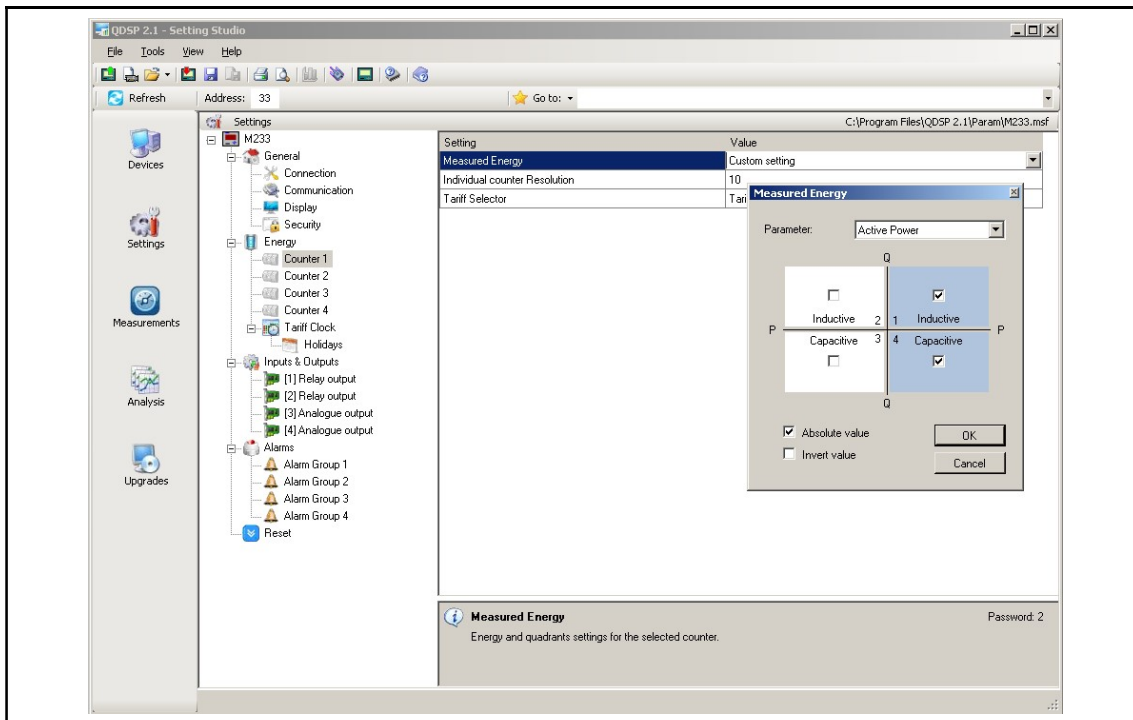

FIGURE 14-4: MEASURED ENERGY

### 13.8.6 Counter divider

The counter divider defines the precision of a specific counter, according to settings of the Common energy exponent.

An example for 12.345kWh of consumed active energy in the first tariff (price 0.1567 €/kWh):

Common energy exponent	0	2	2
Counter divider	1	1	100
Common energy cost exponent	-2	-3	0
Common tariff price exponent	-4	-4	-4
Price for energy in tariff 1	1567	1567	1567
Unit	EUR	EUR	EUR
Example of result, display	12.345 kWh 1.93 EUR	12.3 kWh 1.934 EUR	0.01 MWh 1 EUR

### 13.8.7 Tariff selector

The tariffs selected to be applicable to the specified counter can be defined.

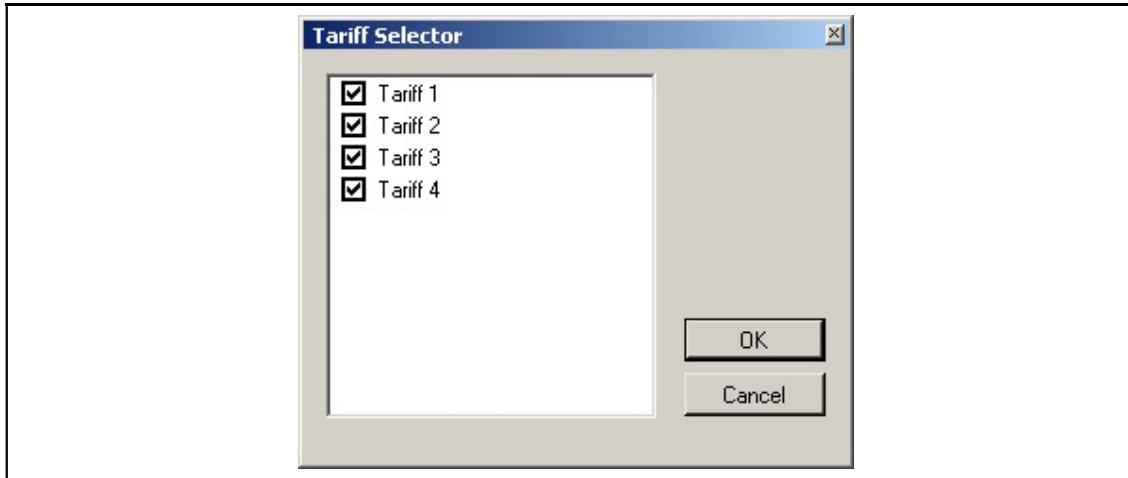

FIGURE 14-5: TARIFF SELECTION

### 13.8.8 Tariff clock

Basic Characteristics of the program tariff clock:

- 4 tariffs (T1 to T4)
- Up to 4 specific times in each day for tariff switching
- A combination of valid days in a week or holidays for each program
- Combining of day groups (use of more than 4 specific times for certain days in a week)
- Separate settings for 4 seasons a year
- Up to 20 settable dates for holidays

Figure 14-6 shows the QDSP Tariff menu. This enables a full tariff structure with 4 seasons and 4 day groups that are configurable. Within each day or season times can also be specified to show rates within the period. The Holiday sub menu is used to specify tariff holidays.

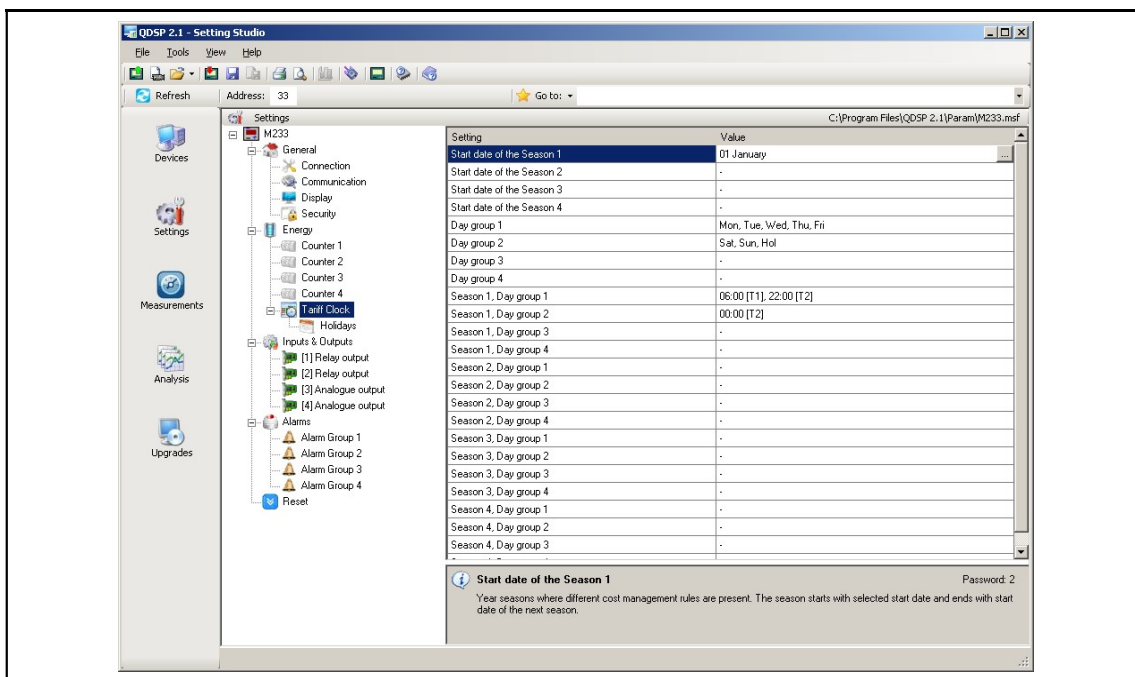

FIGURE 14-6: TARIFF STRUCTURE

The order of seasons and starting dates is not important, except when 2 dates are the same. In that case the season with the highest number will have priority, while the season with a lower number will never be active.

If the actual date is before the first starting date defined for any period, the period with the last starting date becomes active.

Example of settings:

Season	Season start day
Season 1:	15.02
Season 2:	30.10
Season 3:	–
Season 4:	01.06
Date	Active season
01.01. – 14.02.	2 (last in the year)
15.02. – 31.05.	1
01.06. – 29.10.	4
30.10. – 31.12.	2

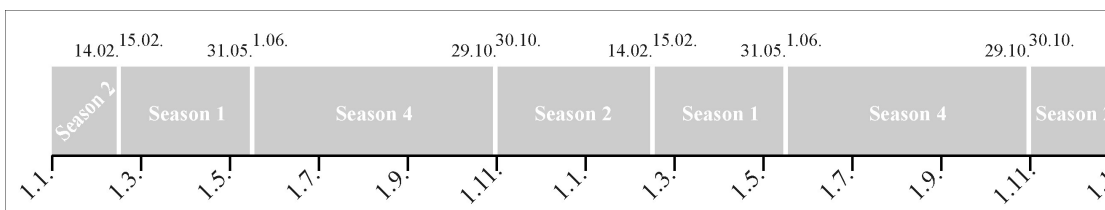

Several daily groups can be active simultaneously, which enables more than 4 time slots in one day (Combination of day programs)

### 13.9 Inputs and Outputs

The module settings displayed will depend on the I/O modules built into the instrument or defined in the settings file if working off-line.

#### 13.9.1 Analogue output module

Each of up to four analogue outputs is fully programmable.

##### 13.9.1.1 Output parameter

Define the Measured or calculated parameter that is to be output on the specific analogue output.

##### 13.9.1.2 Output range

The analogue output can be configured to one of six hardware output ranges within which the analogue output will operate. To ensure the highest accuracy for the output, the range selected should be the lowest that covers the required analogue output range.

DC current output	DC voltage output
-1...0...1 mA	-1...0...1 V
-5...0...5 mA	
-10...0...10 mA	-10...0...10 V
-20...0...20 mA	

### 13.9.1.3 Output signal

This defines the actual range and output curve shape of the required analogue signal. Up to 5 break points can be programmed to achieve the required curve.

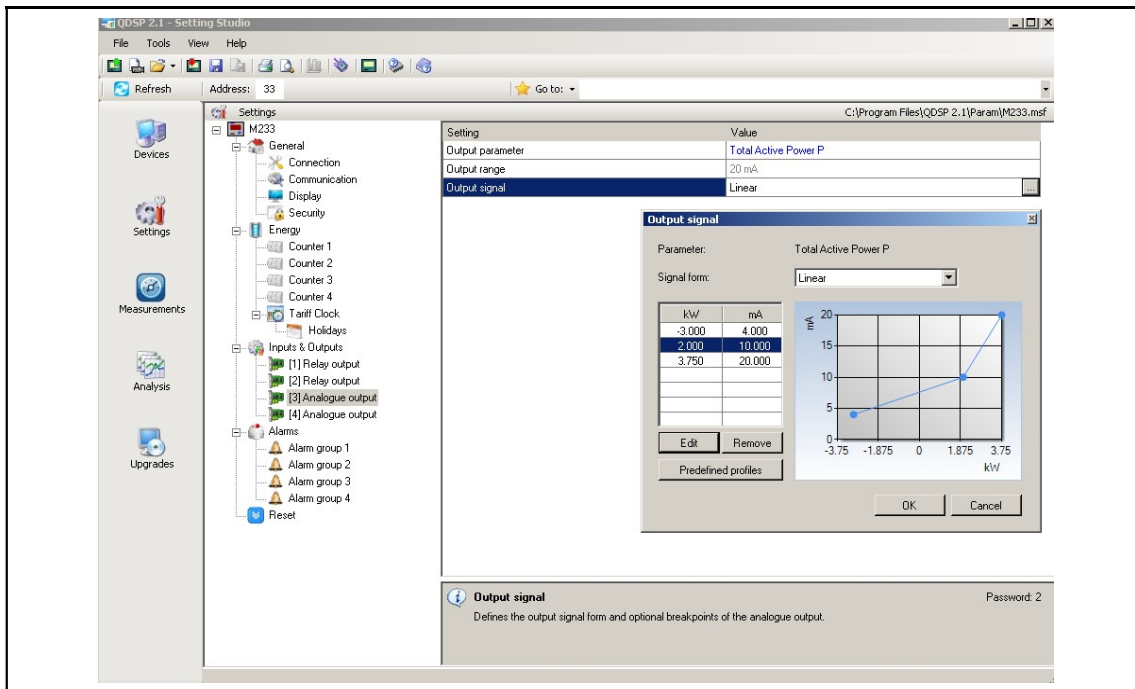

FIGURE 14-7: ANALOGUE OUTPUT SETTINGS

If the Analogue output signal is modified from the full linear range, the accuracy of the output may be reduced due to the reduction in the overall output range.

**Note:** If the 'Used' ranges are changed after the analogue settings have been defined, then the analogue settings will be modified automatically, see section 14.5.3. It may be necessary to subsequently modify the settings for the analogue outputs.

### 13.9.1.4 Average interval for analogue output

Defines the time interval over which the measurement used for an analogue output will be averaged.

### 13.9.2 Alarm/digital output module (KD)

Alarm groups connected with an alarm module and a signal shape are defined.

An alarm module can also function as a pulse output with limited pulse length (min 10ms) or a general purpose digital output. The settings for the pulse option are defined in the same way as for the pulse module. A parallel RC filter with a time constant of at least 150  $\mu$ s ( $R \cdot C \geq 250 \mu$ s) should be fitted when connected to a sensitive pulse counter, to attenuate the relay transient signals.

#### 13.9.2.1 Output signal

The alarm/digital output can be configured for several different signal shapes:

- Normal - The relay is closed until the alarm condition is fulfilled.
- Normal Inverse - The relay is open until the alarm condition is fulfilled.
- Holds - The relay is closed when the alarm condition is fulfilled and remains closed until it is reset via communication.
- Pulse - an impulse of the defined length is sent when the alarm condition is fulfilled.

- Always switched ON/OFF - The relay is switched ON or OFF irrespective of the alarm condition. This enables remote control via communication to be implemented.

### 13.9.3 Pulse output module (KD)

The pulse output module is either defined to an Energy counter or it can be used as an alarm output with limited current load (max 20mA).

When used as a pulse output the number of pulses per energy unit, pulse length and the tariffs in which the output is active are set.

Pulse parameters are defined in EN 62053 - 31, and the following is a simplified rule that satisfies the specification, where 'e' is multiplier.

$$1,5...15 \text{ eW} \rightarrow 100 \text{ p}/1 \text{ eWh}$$

Examples:

Expected power	→	Pulse output settings
150 – 1500 kW	→	1 p/1kWh
1,5 – 15 MW	→	100 p/1MWh
15 – 150 MW	→	10 p/1MWh
150 – 1500 MW	→	1 p/1MWh

### 13.9.4 Tariff input module

There are no settings for the tariff input; they operate by setting the active tariff. With two tariff inputs available a maximum of 4 tariffs can be selected.

### 13.9.5 Digital input module

There are no settings for the digital input; they operate by acting as an input to the Alarms 1 to 32. The input therefore can be used to trigger a software alarm and is available via the communications and can be stored in the alarm data recorder.

### 13.9.6 Watchdog output module (KD)

The purpose is to detect potential malfunction of the transducer or auxiliary power supply failure. This module can be set for normal operation (relay in close position) or for test purposes to open position (manual activation). After test the module should be set back to normal operation.

### 13.9.7 Analogue input module

Three analogue input options are available for acquisition of low voltage DC signals from external sensors. According to the application requirements it is possible to choose current, voltage or resistance (temperature) analogue input options. They all use the same input terminals.

QDSP allows setting of an appropriate calculation factor, exponent and required unit for representation of primary measured value (temperature, pressure, flux...etc. )

#### DC current range:

Range setting allows bipolar  $\pm 20$  mA or  $\pm 2$  mA max. input value.

#### DC voltage range:

Range setting allows bipolar  $\pm 10$  V or  $\pm 1$  V max. input value.

#### Resistance / temperature range:

Range setting allows  $2000\Omega$  or  $200 \Omega$  maximum input value.

It is also possible to choose temperature sensor (PT100 or PT1000) with direct translation into temperature (-200°C to +850°C). Since only two-wire connection is possible it is recommended that the wire resistance is also set, when long leads are used.

The measured input can be used to set alarms or generate an analogue output with different scaling. The value is available via communications and can be stored in the data recorder.

### 13.9.8 Pulse input module

There are no settings for the Pulse Input module. It acts as a general purpose pulse counter from external meters (water, gas, heat ...). Its value can be assigned to any of the four energy counters.

### 13.9.9 2<sup>nd</sup> communications module (COM2) (KD)

The module is fitted as RS485 or RS232 communications and is fitted as Module 2.

The module settings define parameters that are important for the operation. Factory settings for the communication parameters are #33\19200 (or 115200), n, 8, 1 (address 1 to 247/rate 2400 to 115200, parity, data bits, stop bit).

The COM2 communications port has a device address that is set independently of that used by COM1. This allows two independent communications networks to be connected to the same transducer.

## 13.10 Alarms

There are 32 alarms available split into 4 alarm groups. On the **M243** and **M253** changes in the status of any alarm can be stored into the Alarm recorder.

### 13.10.1 Alarm setting

For each of the 4 alarm groups a time constant of maximum values in thermal mode, a delay on time and alarm deactivation hysteresis can be defined.

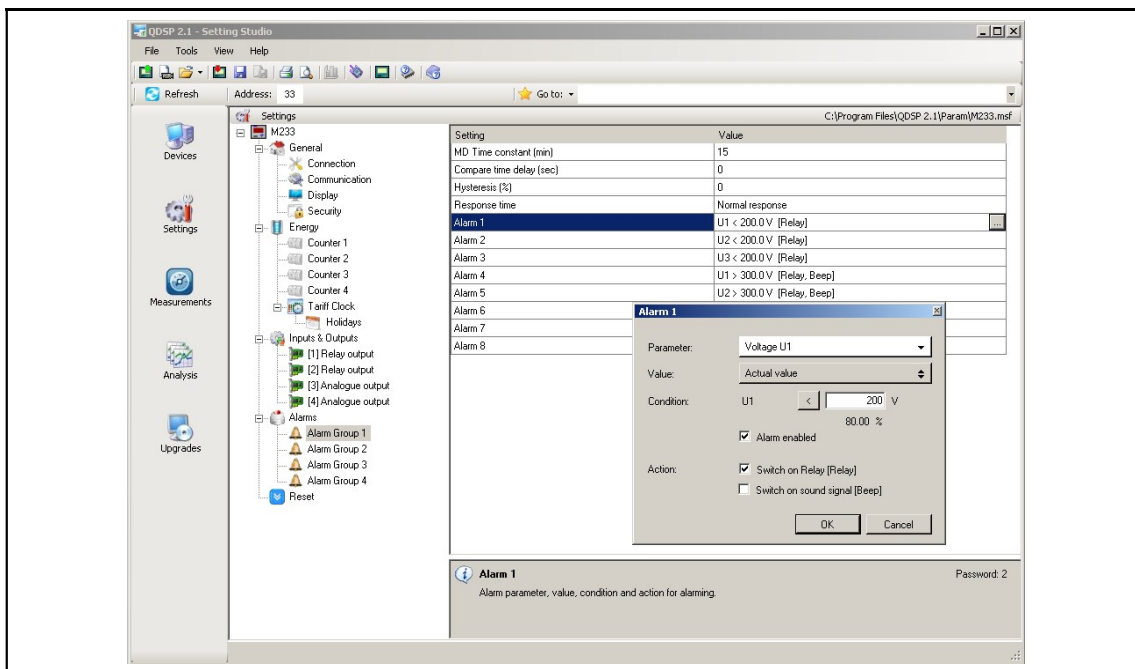

FIGURE 14-8: QDSP ALARM SETTINGS

For each individual alarm a parameter, value (actual value or MD- thermal) and the condition for alarm switching are defined. In addition, it is defined if a relay is to be switched and, a beep on alarm.

**Note:** If the 'Used' ranges are changed after the alarm settings have been defined, then the alarm settings will be modified automatically, see section 14.5.3. It may be necessary to subsequently modify the settings for the alarm outputs.

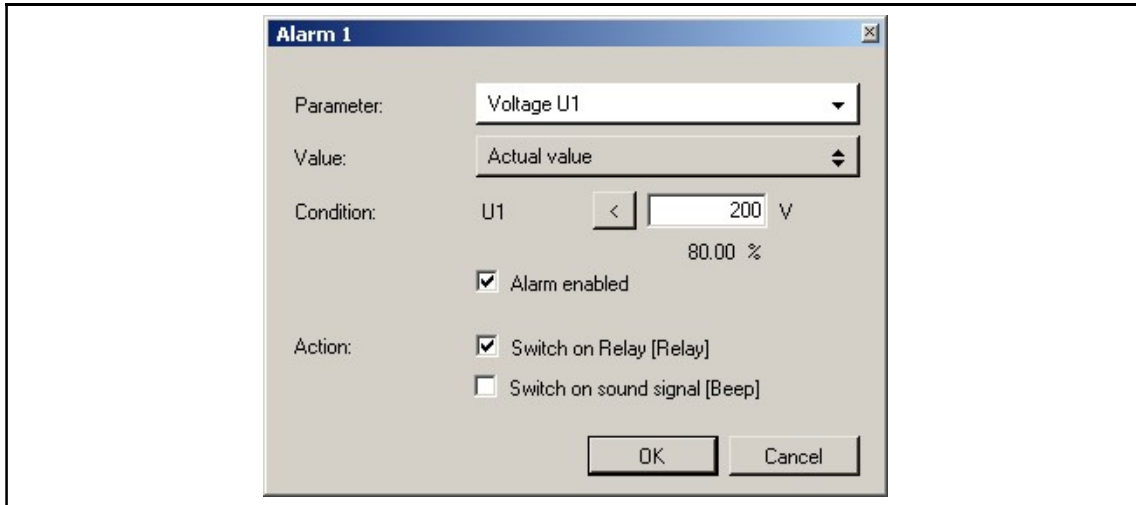

FIGURE 14-9: ALARM SETTINGS

If a digital input module is fitted to the unit, then the status of the input can be defined as the parameter.

13.10.2 Types of alarm

13.10.2.1 Visual alarm

When an alarm is switched on, a red LED on the front of the device will blink.

13.10.2.2 Audible alarm

When an alarm is switched on, an audible alarm is given by the device (a beep). It can be switched off by pressing any key on the front plate.

13.10.2.3 Alarm output (pulse)

According to the alarm signal shape the output relay will behave as shown below.

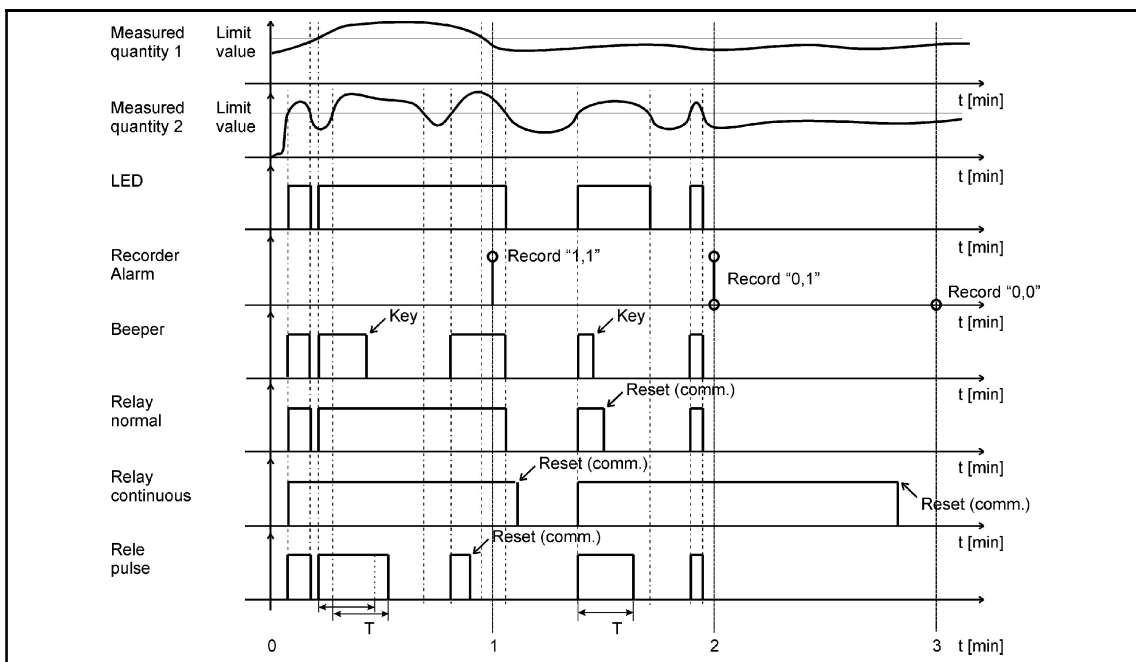

FIGURE 14-10: ALARM OUTPUTS

## 13.11 Memory

Measurements, alarms, reports, and details of supply voltage quality can be stored in the 8MB of internal memory on the **M243** and **M253**. All records stored in the memory are accessible using QDSP.

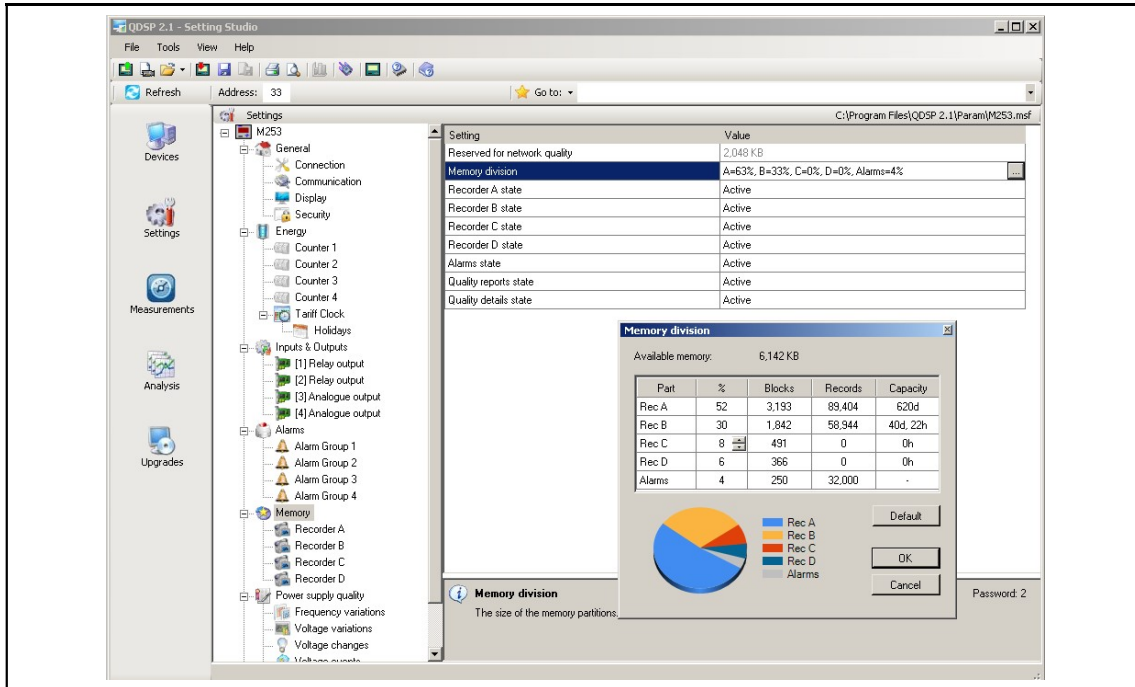

FIGURE 14-11: MEMORY SETTINGS

### 13.11.1 Memory division

The internal memory is divided into up to 5 partitions, recorders A - D and Alarms, whose size can be defined by the customer, see Figure 14-11. Recorders A - D are intended for recording measurements, while alarms are recorded in a separate partition. The **M253** has 2 additional partitions for recording reports and details on the quality of supply voltage.

### 13.11.2 Memory clearing

There is usually no need to clear the memory as it works in cyclic mode in FIFO method with the oldest records being overwritten when new records are stored. If you need to clear memory, then follow these steps:

- Read the instrument readings with QDSP and set "Recorder state" in Memory to 'stopped'.
- Download the changes to the device and open Memory info form and then click on Clear memory button.
- Select memory partitions to be cleared on Memory form and click OK.
- Set "Recorder state" setting back to 'Active'.

## 13.12 Data Recorders

The **M243** and **M253** have up to four data recorders, which can only be configured using the QDSP software. These recorders are independent from each other, and each can be configured to record up to 16 different values. The Maximum Demand Integration time can be set between 1 and 255 minutes and the Recorder sample time can be set between 1 and 255 minutes.

Figure 14-12 shows the QDSP Data Recorder menu. This shows the 16 different record values for each of the recorders, each of which is configurable to any ac measurement or analogue /digital input to the **M2x3**.

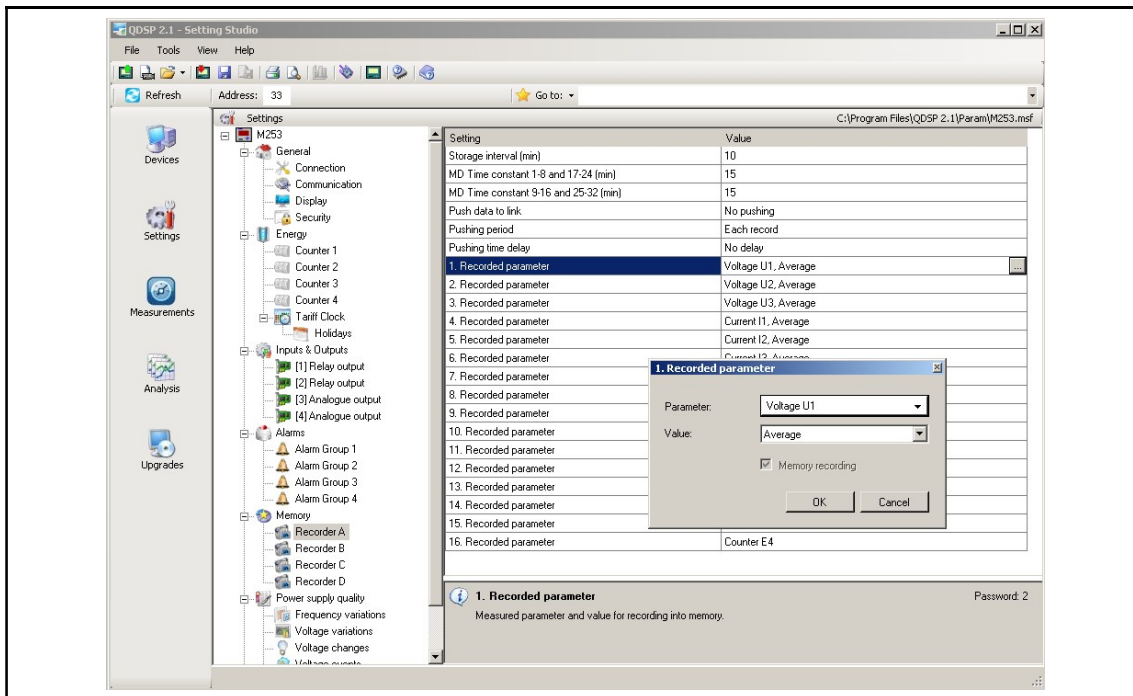

FIGURE 14-12: DATA RECORDER

### 13.12.1 Storage interval

The storage interval sets a time interval for readings to be recorded. This can be different for each recorder partition.

### 13.12.2 MD time constant

When maximum demand values are to be recorded, this setting sets a period for calculation of maximum and minimum value in thermal mode (Minimum (MD) or Maximum (MD)). Different parameters can be set for Recorded parameters 1-8 and 9-16.

### 13.12.3 Recorded quantities

For each measurement to be recorded it is possible to set the required quantity and its type.

#### Parameter

The required monitoring quantity can be selected from a list of supported measurements. Besides the primary electrical quantities, auxiliary quantities from the input modules can also be selected.

#### Value

The type of the selected quantity to be recorded can be defined.

- **Minimum and Maximum** value represents minimum or maximum of the recorded averaged values within the selected storage interval. Note that the minimum and maximum values are not single period values but an average (0.1 s to 5 s).
- **Minimum (MD) and Maximum (MD)** value represents the calculation of a MD value with applied thermal function.
- **Average** value represents the calculated average value within the selected storage interval.
- **Actual** value represents the first momentary value within the selected storage interval. Note that momentary values are not a single period value but an average (0.1s to 5s). (recommended for Pst and Plt measurements).
- **Minimum and Maximum (Period)** values represent the minimum or maximum values within the selected storage interval calculated in a single period. This function allows recording of very fast changes.

### 13.13 Power Quality Recorder Report

The **M253** has a power quality measurement function that monitors compliance to the European standard EN50160. The power quality features can be set on the **M253**, and this then determines what data is communicated.

The EN 50160 standard deals with voltage characteristics of electricity supplied by public distribution systems. This specifies the limits or values within which a customer can expect voltage characteristics to lie. Within this definition the **M253** Network Analyser supervises the compliance of distribution systems with the EN 50160 standard.

Based on the requirements stated in the standard, default parameters are set in the meter according to which supervision of all required parameters is done. Parameters can also be changed in detailed setting of individual characteristics.

The **M253** has 2MB of non-volatile memory reserved for storing power quality data with a capacity for storing 170,000 variations from standard.

The EN50160 standard monitors the following electrical characteristics:

- Frequency and voltage variations
- Voltage unbalances, interruptions, and dips
- Long and Transient (fast) interruptions
- Flicker, short and long term
- Individual Harmonics and %THD

All the Power Quality settings, extraction and tabulation of findings require the **QDSP** software.

The following definitions are used in Power Quality applications:

Un = nominal supply voltage for the electrical system

Uc = agreed supply voltage for the electrical system, this may be the same as Un.

#### 13.13.1 Power supply quality

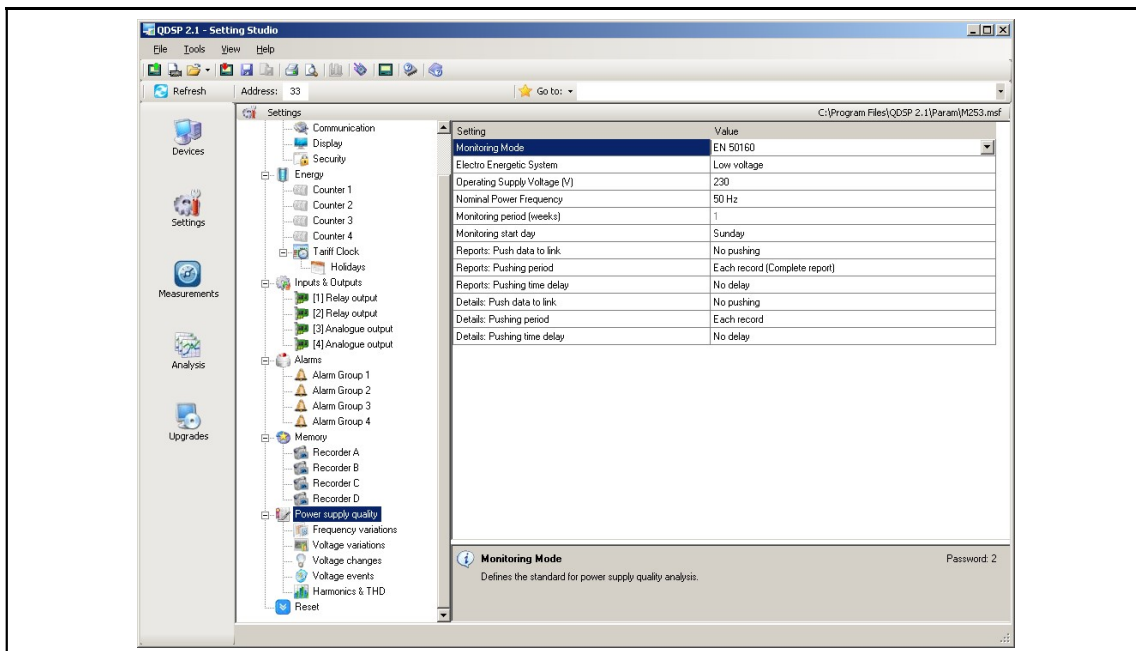

FIGURE 14-13: POWER SUPPLY QUALITY

Basic parameters are defined that influence other settings.

#### 13.13.1.1 Monitoring mode

This defines that the instrument performs measurements for network compliance with the standard.

#### 13.13.1.2 Electric energetic system

Public distribution system and if necessary, all default settings are selected.

#### 13.13.1.3 Nominal supply voltage

A value that is usually equal to nominal network voltage is entered.

#### 13.13.1.4 Nominal power frequency

Nominal frequency of supply voltage is selected.

#### 13.13.1.5 Monitoring period

For a report of electric voltage quality, a monitoring period is defined. Several monitored weeks are entered.

#### 13.13.1.6 Monitoring start day

A starting day in the week is selected. It starts at 00:00 (midnight). The selected day will be the first day in a report.

#### 13.13.1.7 Voltage hysteresis

Hysteresis for voltage dips, interruptions and overvoltages is set in percentage from nominal voltage.

#### 13.13.2 Frequency variations

All frequency measurements are performed in 10-second averaging intervals. There are two variation classes and for each a variation is defined as a percentage of nominal and the percentage of measurements which must be within the variation limits (required quality).

#### 13.13.3 Voltage variations

All Voltage measurements are performed in 10-second averaging intervals. There are two variation classes and for each a variation is defined as a percentage of nominal and the percentage of measurements which must be within the variation limits (required quality).

#### 13.13.4 Dips and interruptions

Limits for voltage dips and interruptions are defined as a percentage of the nominal voltage. A threshold between short-term and long-term interruptions is defined in seconds. Also, the allowable number of dips and interruptions are defined by other parameters.

#### 13.13.5 Rapid voltage changes

The limits and the number of allowable changes is defined.

#### 13.13.6 Temporary overvoltages, flickers

There are two types of flicker: short-term flicker intensity ( $P_{st}$ ) and long-term flicker intensity ( $P_{lt}$ ) for each a monitoring period, performance limit and required signal quality are defined.

#### 13.13.7 Harmonics and THD

The permitted limits for the first 25 harmonic components and the THD are defined with the required quality in the monitoring period.

#### 13.13.8 Resetting quality parameter reports

Some quality parameter reports are made on a weekly basis and others on a yearly basis. The parameter reports are reset at the end of each observed period. Weekly based reports will be reset every week. Even if the instruments' location or mode of operation is altered, the weekly report will reset at the end of the week. But yearly reports will not be reset until the end of the year. Therefore, when required the yearly reports must be reset manually.

To reset reports, choose setting <Power supply quality>< Monitoring mode> and change the value to "No monitoring". Download settings to instrument. Then choose the same setting and change the value back to "EN50160". Again, download the settings to the instrument. Then all yearly reports (anomaly counters) will have been reset

### 13.14 Reset Operations

#### 13.14.1 Reset min/max values (KD)

All Min/Max values are reset.

#### 13.14.2 Set energy counters (KD)

All or individual energy counters are reset.

#### 13.14.3 Reset energy counter costs (KD)

All or individual energy costs are reset.

#### 13.14.4 Reset maximal MD values (KD)

##### 13.14.4.1 Thermal mode

Current and stored MDs are reset.

##### 13.14.4.2 Fixed interval/sliding window

The values in the current time interval, in all sub-windows and stored MD are reset. At the same time, synchronization of the time interval to the beginning of the first sub-window is also performed.

#### 13.14.5 Reset the last MD period (KD)

##### 13.14.5.1 Thermal mode

Current MD value is reset.

##### 13.14.5.2 Fixed interval/sliding windows

Values in the current time interval and in all sub-windows for sliding windows are reset. At the same time, synchronization of the time interval is also performed.

#### 13.14.6 MD synchronization (KD)

##### 13.14.6.1 Thermal mode

In this mode, synchronization does not have any influence.

##### 13.14.6.2 Fixed interval/sliding windows

Synchronisation sets time in a period or a sub-period for sliding windows to 0 (zero). If the interval is set to 2, 3, 4, 5, 6, 10, 12, 15, 20, 30 or 60 minutes, time set in a period is set to such a value that some intervals will be terminated at completed hour.

Example:

Time constant (interval)	15 min	10 min	7 min
Synchronization start time	10:42	10:42	10:42
Time in a period	12 min	2 min	0 min
First final interval	10:45	10:50	10:49

#### 13.14.7 Reset alarm output (KD)

All alarm outputs are reset.

---

## **14. COMMUNICATIONS**

### **14.1 Communications ports**

The **M233**, **M243** and **M253** are fitted with a primary communications (COM1) port and an optional secondary port (COM2).

COM1 can be RS232/RS485, USB, Ethernet, or Ethernet and USB

COM2 can be RS232 or RS485

Both communications ports can be used for settings and the monitoring of data, they operate completely independently of each other.

The communication parameters of the **M2x3** can be obtained by using the keypad and display or by using the 'Scan the network' feature in the QDSP setting software.

### **14.2 QDSP Setting and Monitoring Software**

See the separate QDSP Manual for details of how to Install and use the QDSP Software.

### **14.3 MODBUS**

For details, see the separate **M2x3 & I500** Communications Manual.

### **14.4 DNP3**

The implementation of DNP3 in the **M2x3** is basic and some DNP3 Masters may have difficulty interfacing to the **M2x3**.

For details, see the separate **M2x3 & I500** Communications Manual.

## 15. SUPPORT POWER FOR REAL TIME CLOCK OPERATION

To maintain the operation of the Real Time Clock (not in **M203**, **M213**) during periods when the Auxiliary power supply is not connected an internal power source is required.

**M2x3** products using Hardware version 'B' or earlier use a replaceable battery. M2x3 products labelled as Hardware version 'C' use a super capacitor that is not replaceable.

### 15.1 Battery Replacement

The measuring centre may contain a lithium battery. It is used to power the Real Time Clock (date and time) in the device when the auxiliary power supply is not connected. The Lifetime of the battery is approximately 6 years (typical) but high temperatures and humidity can shorten the battery's life.

When the battery is expired and the power supply is interrupted, the flashing battery indicator appears in the top right corner of the display (before that it is not visible). **The Battery has no effect on other functionality of the device, except date and time.**

It is recommended that the instrument is sent back in the factory for battery replacement. Please note that the battery is soldered into the PCB.

#### 15.1.1 Instructions for replacement

1. Disconnect the instrument from measuring grid and power supply (Caution! - Read the safety section!) and take it out of the panel.
2. Remove frame [1] from the instrument (see Figure 16.1).
3. Pull out front assembly [2+3].
4. Remove PCB [3] from case [2] (Read section on 'HANDLING OF ELECTRONIC EQUIPMENT').
5. Remove the battery (soldered) from the board, be careful to use proper tools, and replace it with the same model (Varta, type 6032 CR2032 SLF).
6. To put the instrument together follow steps 2 to 4 in reverse order.
7. Set device date and time.

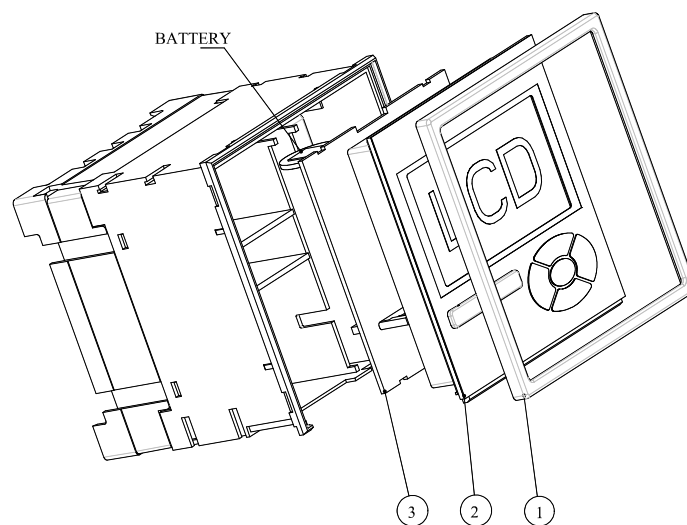

FIGURE 16-1: BATTERY REPLACEMENT

## 15.2 Operation with the super capacitor

A Super Capacitor has the advantage that it should never need to be replaced during the life of the product it is fitted in.

But, unlike a battery which could support the operation of the clock for a long time, the Super Capacitor, when fully charged, can only support the clock for a period of 72 hours when auxiliary power is not connected, after which the clock will stop working. When power is re-connected the clock will need to be reprogrammed, and this can be easily done using the product keypad or the QDSP setting software.

When powering up an **M2x3** after the clock has stopped working, the clock setting will be displayed showing that it needs to be set. A message will be displayed on QDSP, if connected, defining that the clock needs to be set. And the status of the clock can be checked by an external SCADA to confirm if the clock needs to be set.

Only the clock operation is affected, all settings and data are maintained in non-volatile memory, which does not require any power to maintain the data.

The **M2x3** will continue to operate correctly when the clock has stopped, except that any measurements which are stored with a time stamp will have an incorrect time stamp and Energy Tariffs based on time and date will not give the correct results. This is the same if a battery fails or the Super Capacitor becomes discharged.

## 16. TECHNICAL DATA

INPUTS AND SUPPLY		
Voltage input	Nominal Rating (Un)	230 V <sub>LN</sub> , 415 V <sub>LL</sub>
	Max. allowed value	277 V <sub>LN</sub> , 480 V <sub>LL</sub> permanently 2 x Un for 10 seconds
	Minimum range	2.0V sinusoidal
	Burden	<0.1 VA per phase
Current input	Nominal current (In)	5A
	Rating (Auto-ranging)	1A/5A
	Overload	3 x In continuously 25 x In for 3 seconds 50 x In for 1 second
	Minimal range	Starting current for power
	Maximum range	12.5A sinusoidal
	Burden	<0.1 VA per phase
Frequency	Nominal Frequency (Fn)	50/ 60Hz
	Measuring range	16 to 400Hz
	Rating	10 to 1000 Hz
Supply - universal	Nominal AC voltage	48 to 276Vac
	Nominal frequency	40 to 70Hz
	Nominal DC voltage	20 to 300Vdc
	Burden	< 12 VA
Supply - AC	Nominal AC voltage	57.7V, 63.5V, 100V, 110V, 230V, 400V, 500V
	Nominal frequency	40 to 65Hz
	Burden	< 8 VA
Battery (if fitted)	Type	CR2032 Li battery
	Nominal voltage	3V
	Life	Approx. 6 years @ 23C

CONNECTIONS	
Permitted conductor cross sections	Maximum conductor cross section
Voltage terminals (4)	≤ 5mm <sup>2</sup> one conductor
Current terminals (3)	≤ 6mm diameter conductor with insulation
Supply (2)	≤ 2.5mm <sup>2</sup> one conductor
Modules (2 x 3)	≤ 2.5mm <sup>2</sup> one conductor

<b>ACCURACY</b>		<b>(of range unless specified)</b>
RMS current ( $I_1, I_2, I_3, I_{avg}, I_n$ )	1A	Class 0.2 or 0.5
	5A	Class 0.2 or 0.5
RMS line voltage ( $U_1, U_2, U_3, U_{avg}$ )	75V L-N	Class 0.2 or 0.5
	250V L-N	Class 0.2 or 0.5
RMS phase-phase voltage ( $U_{12}, U_{23}, U_{31}, U_{avg}$ )	120V L-L	Class 0.2 or 0.5
	400V L-L	Class 0.2 or 0.5
Frequency		
F (current)	50Hz	0.01Hz
F (10 second average)	50Hz	0.01Hz
Power angle	-180...0...180°	Class 0.5
Power factor	-1...0...+1	
	U = 50 ... 120 % $U_n$	Class 2.0
	I = 2 % ... 20 % $I_n$ I = 20 % ... 200 % $I_n$	Class 1.0
Maximum demand	Calculated from U and I	Class 1.0
THD	5 to 500V	Class 0.5
	0 to 400%	Class 0.5
Power		
Active W	Calculated from U and I	Class 0.2 or 0.5
Reactive VAR: Q, apparent VA : S	Calculated from U and I	Class 0.5 or 1
Energy		
Active energy	Calculated from U and I	Class 0.5S or 1 to EN 62053-22
Reactive energy	Calculated from U and I	Class 2 to EN 62053-23
Real time clock (if powered)		1minute per month (30ppm)
Analogue output (internal supply)	0...20mA	± 200 $\mu$ A

<b>MODULES</b>			
Alarm module	No of outputs	2	
Watchdog/alarm module	Rated voltage	48 V AC/DC (+40%)	
	Max switching current	1000 m A	
	Insulation		1000V ac between open contacts
			4000V ac between coil and contacts
	Pulse	Max 4000 imp/hour, Min width 100ms	
	Modes	Normal, pulsed or permanent	

MODULES		
Bi-stable alarm module	No of outputs	1
	Max. switching power	40 VA
	Max. switching voltage AC	40 V
	Max. switching voltage DC	35 V
	Max switching current	1 A
	Modes	Normal, pulsed or permanent
Energy pulse module	No of outputs	2
	Maximum voltage	40 V AC/DC
	Maximum current	30 mA
Analogue output module	No of outputs	2
	Maximum load	150Ω
	Output range	0 ... 20mA
Tariff module	No of inputs	2
	Voltage	230V/110V ± 20% AC
Pulse input module	No of inputs	2
	Rated voltage	5 - 48 V DC (± 20%)
	Max. current	8 mA (at 48 VDC + 20%)
	Min. pulse width	0.5 ms
	Min. pulse period	2 ms
	SET voltage	40...120 % of rated voltage
	RESET voltage	0...10 % of rated voltage
Digital input module	No of inputs	2
	Voltage	230V/110V ± 20% AC/DC
2 <sup>nd</sup> communications module RS232/RS485	No. of channels	1
	Type of connection	Direct / Network
	Maximum connection length	3 m / 1000 m
Analogue input module	Number of Inputs	2
	Nominal input range 1	-20...0...20 mA (±20%)
	Nominal input range 2	-2...0...2 mA (± 20%)
	input resistance	20 Ω
	accuracy	0.5 % of range
	temperature drift	0.1% / °C (for range 2 only)
	conversion resolution	16 bit (sigma-delta)
	Analogue input mode	internally referenced Single-ended
	Nominal input range1	-10...0...10 V (±20%)
	Nominal input range 2	-1...0...1 V (±20%)
input resistance	100 kΩ	
accuracy	0.5 % of range	
temperature drift	0.1% / °C (for range 2 only)	
conversion resolution	16 bit (sigma-delta)	
Analogue input mode	internally referenced Single-ended	

MODULES	
Nominal input range (low)*	0 - 200 $\Omega$ (max. 400 $\Omega$ ) PT100 (-200°C-850°C)
Nominal input range (high)*	0 - 2 k $\Omega$ (max. 4 k $\Omega$ ) PT1000 (-200°C-850°C)
connection	2-wire
accuracy	0.5 % of range
conversion resolution	16 bit (sigma-delta)
Analogue input mode	internally referenced Single-ended
* Low or high input range and primary input value (resistance or temperature) are set by the QDSP setting software	

COMMUNICATION				
	Ethernet	USB	RS232	RS485
Connection	Direct	Direct	Direct	Network
Max connection length	-	-	3M	1000M
Terminals	RJ45	USB-B	DB9 female or terminals	
Transmission mode	Asynchronous			
Protocol	MODBUS TCP/RTU & DNP3 (autodetect)	MODBUS RTU / DNP3 (autodetect)		
Insulation	3.7KV, 1 minute between terminals and all other circuits			
Transfer rate	10/100Mb/s (autodetect)	USB 2.0	2400 to 115200b/s	

ELECTRONIC FEATURES		
LCD	Type	Graphic, 128 x 64 pixels
	Refresh time	200 mS
Response time	Input to LCD	Calculated during averaging interval setting (8 to 256 periods), resetting (64 periods) typically 1.28 seconds at 50Hz
	Input to communications	
	Input to relay output	
Memory	M243 (sampling period 1 to 60min)	8MB (recorder A, recorder B, alarm recorder)
	M253 (sampling period 1 to 60min)	8MB (recorder A, recorder B, alarm recorder, Power Quality reports)
LED	Memory card	Green for activity
	Communications	Green for transmission
	Alarm	Red for alarm

SAFETY FEATURES	
General	In compliance with EN61010-1:2004 600Vrms, installation category II 300Vrms, installation category III Pollution degree 2
Test voltage	3.7KV, 1minute In compliance with EN61010-1:2004

SAFETY FEATURES		
EMC	Directive on electromagnetic compatibility 2004/108/EC In compliance with EN 61326-1: 1998	
Protection	In compliance with EN60529:1997 Front with protection cover for Memory Card slot fitted: IP52 Rear with protection cover: IP20	
Ambient conditions	Climatic	Class 3, in compliance with EN62052-11:2004 and EN62052-21:2005
	Temperature	Operation -5 to +55C Storage -25 to +70C
	Humidity	≤ 90%RH
	Height	0 to 2000M
Enclosure	DIN	PC incombustibility - self-extinguishing in compliance with UL94VO
	Mass	Approx 600g

**17. WIRING DIAGRAMS AND CASE DIMENSIONS**

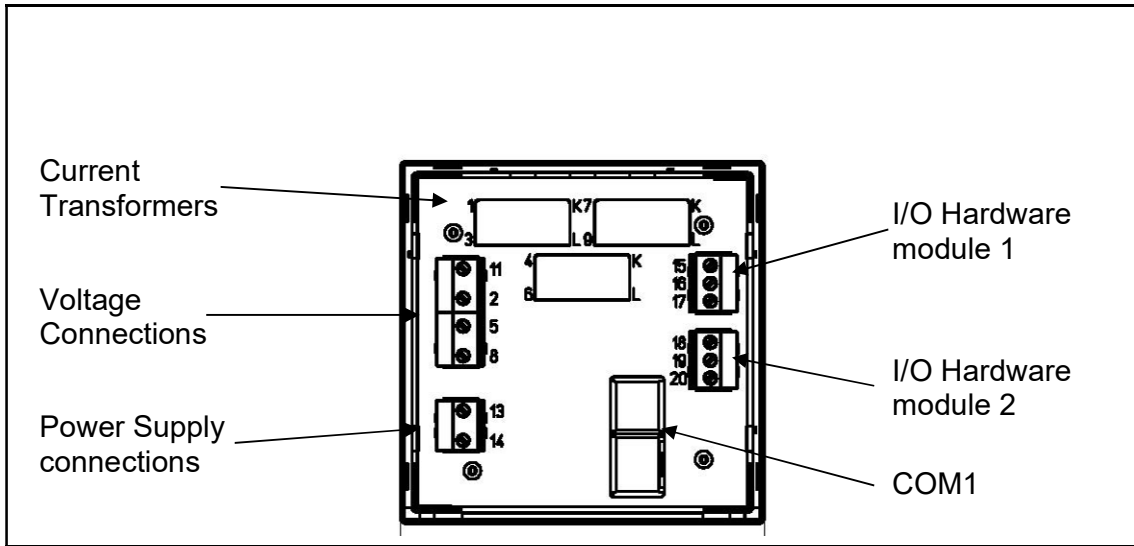

FIGURE 18-1: CONNECTIONS

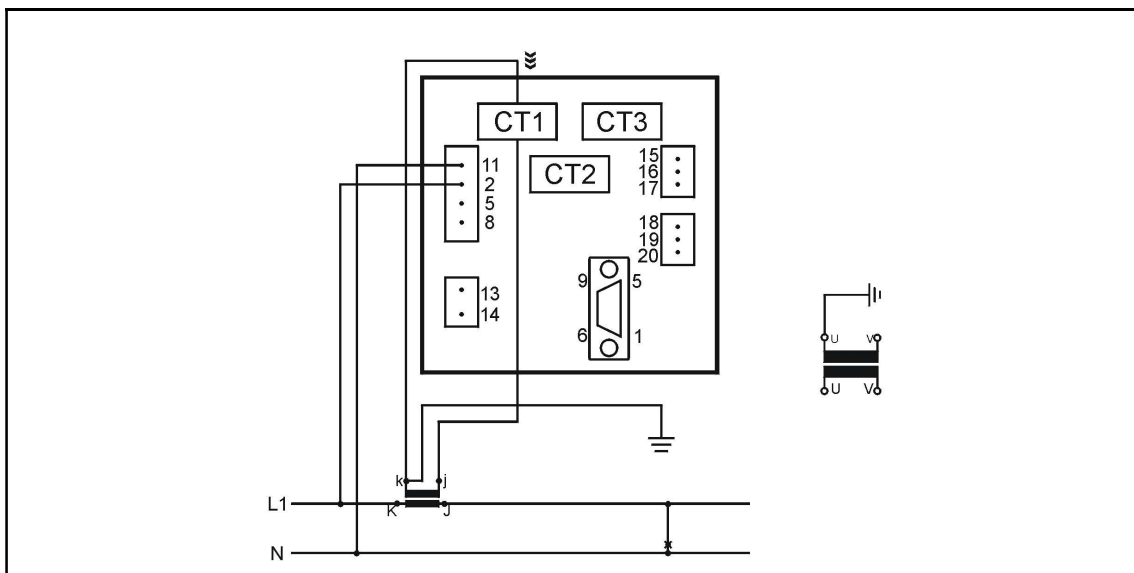

FIGURE 18-2: EXTERNAL WIRING DIAGRAM: SINGLE PHASE (1B)

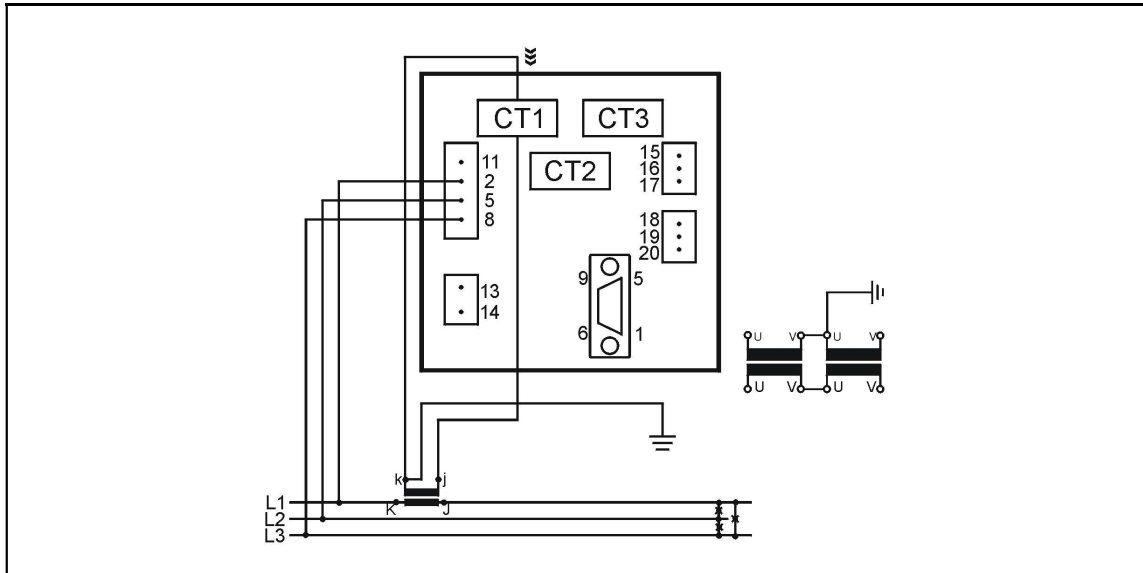

FIGURE 18-3: EXTERNAL WIRING DIAGRAM: 3-PHASE, 3-WIRE BALANCED LOAD (3B)

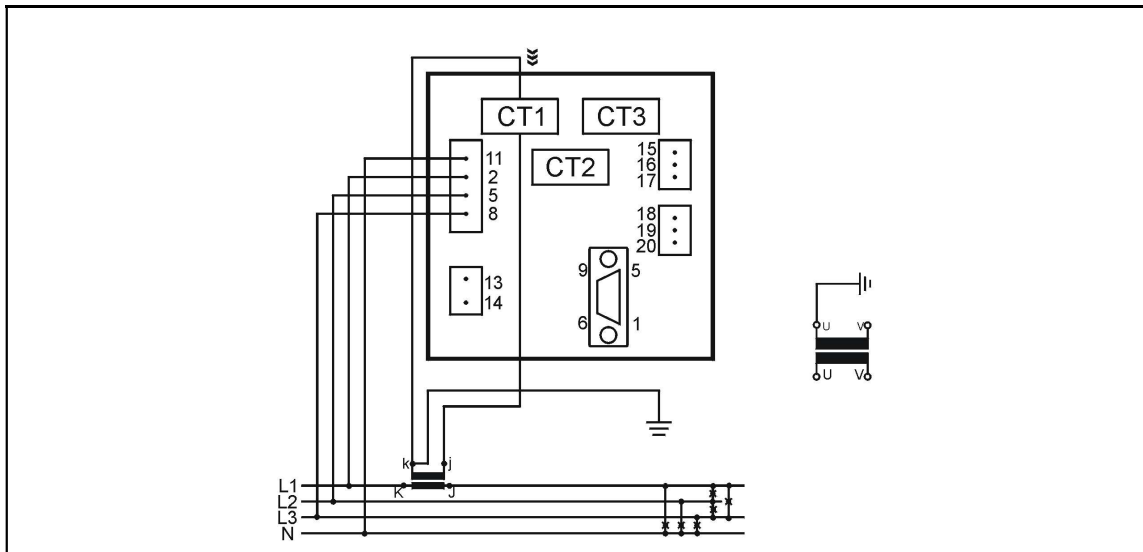

FIGURE 18-4: EXTERNAL WIRING DIAGRAM: 3-PHASE, 4-WIRE BALANCED LOAD (4B)

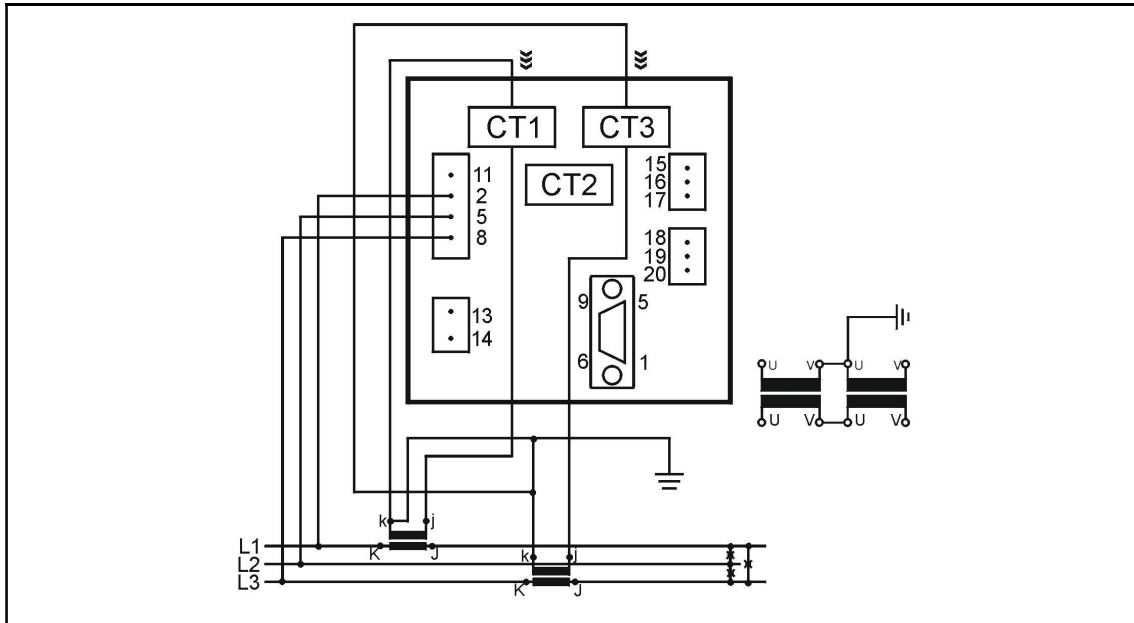

FIGURE 18-5: EXTERNAL WIRING DIAGRAM: 3-PHASE, 3-WIRE UNBALANCED LOAD (3U)

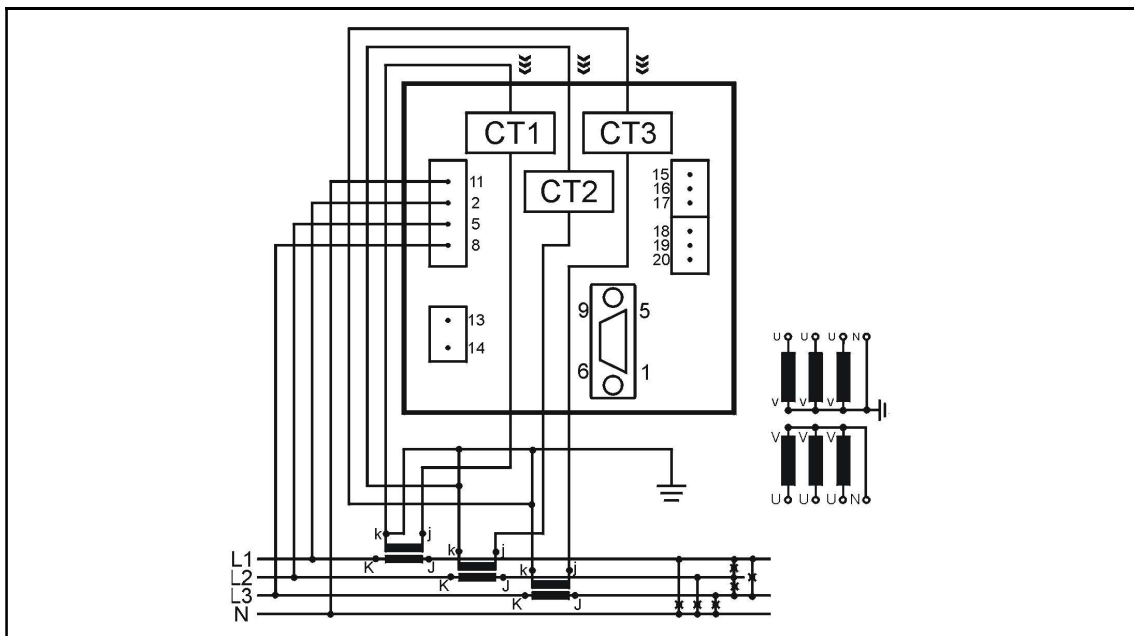

FIGURE 18-6: EXTERNAL WIRING DIAGRAM: 3-PHASE, 4-WIRE UNBALANCED LOAD (4U)

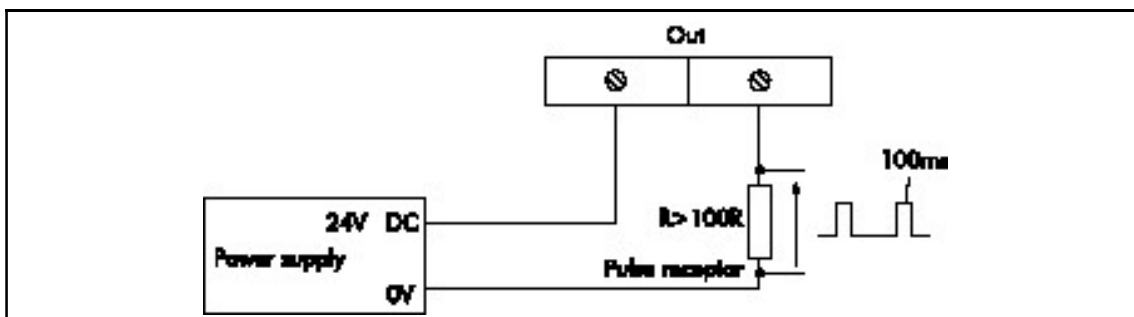

FIGURE 18-7: TYPICAL CONNECTIONS FOR PULSE OUTPUT

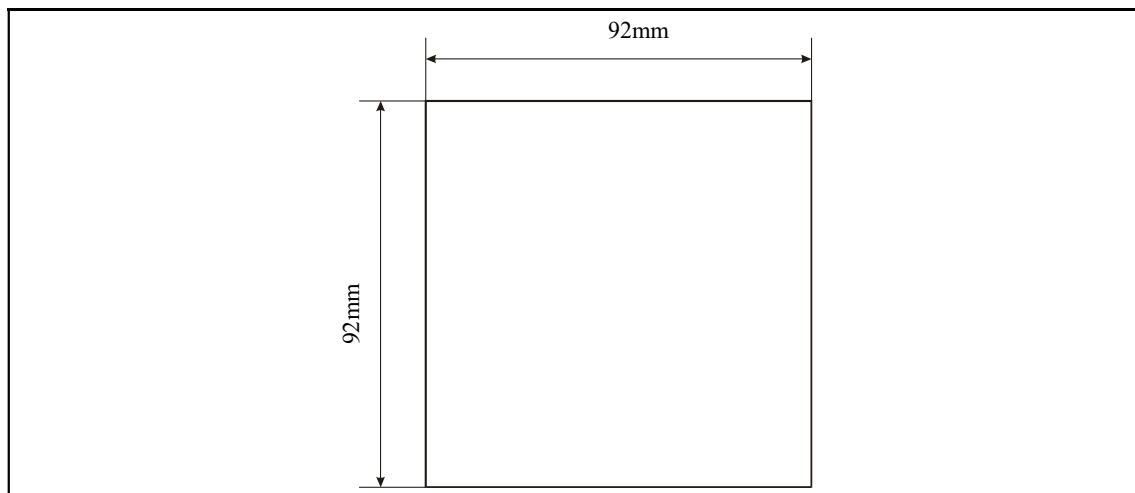

FIGURE 18-8: CUT OUT

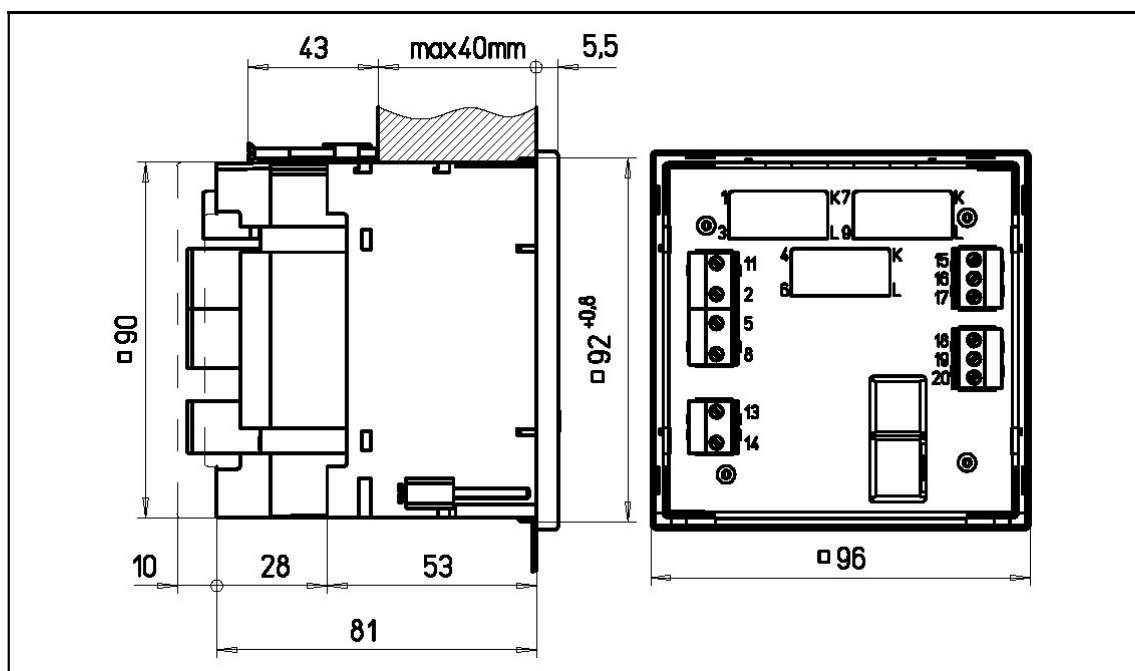

FIGURE 18-9: CASE DIMENSIONS

---

**18. RELATED DOCUMENTS**

<b>Ref</b>	<b>Document</b>
1	M2x3 and I500 Communications Manual
2	QDSP: iSTAT Configuration and Analysis Software Manual





GE VERNOVA

GE Vernova  
St Leonards Building  
Redhill Business Park  
Stafford, ST16 1WT, UK  
+44 (0) 1785 250 070  
[www.gevernova.com/grid-solutions/contact.htm](http://www.gevernova.com/grid-solutions/contact.htm)

© 2025 GE Vernova. All rights reserved. Information contained in this document is indicative only.  
No representation or warranty is given or should be relied on that it is complete or correct or will apply to any particular project.  
This will depend on the technical and commercial circumstances. It is provided without liability and is subject to change without  
notice. Reproduction, use or disclosure to third parties, without express written authority, is strictly prohibited.

iSTAT M2x3/EN/M/G