

GE Vernova  
Grid Solutions

# iSTAT M365A/M365B

## Power Quality Analyzer

**Technical Manual**

Publication reference: M365A/B-TM-EN-1.1



GE VERNOVA



# Table of contents

<b>ISTAT M365A/M365B</b> .....	<b>1</b>
<b>WARNINGS, INFORMATION AND NOTES</b> .....	<b>2</b>
<b>BEFORE SWITCHING THE DEVICE ON</b> .....	<b>3</b>
<b>DEVICE SWITCH OFF WARNING</b> .....	<b>4</b>
<b>HEALTH AND SAFETY</b> .....	<b>5</b>
<b>REAL TIME CLOCK</b> .....	<b>6</b>
<b>DISPOSAL</b> .....	<b>7</b>
<b>BASIC DESCRIPTION AND OPERATION</b> .....	<b>8</b>
CONTENTS .....	8
DESCRIPTION OF THE ISTAT M365A/M365B .....	9
ABBREVIATION/GLOSSARY .....	11
PURPOSE AND USE OF THE ISTAT M365A/M365B .....	12
ISTAT M365A/M365B APPLICATION AND BENEFITS.....	13
MAIN FEATURES, SUPPORTED OPTIONS AND FUNCTIONALITY OF ISTAT M365A/M365B.....	14
<b>CONNECTION</b> .....	<b>18</b>
MOUNTING .....	18
ELECTRICAL CONNECTION FOR ISTAT M365A/M365B.....	20
CONNECTION OF INPUT/OUTPUT MODULES.....	22
COMMUNICATION CONNECTION.....	25
CONNECTION OF REAL TIME SYNCHRONIZATION MODULE C.....	25
CONNECTION OF AUX. POWER SUPPLY .....	27
<b>FIRST STEPS</b> .....	<b>28</b>
KEYBOARD NAVIGATION .....	28
INSTALLATION WIZARD.....	29
NOTIFICATION ICONS (M365B ONLY).....	33
SCREEN NAVIGATION.....	34
SETTINGS.....	35
QDSP2.1 SOFTWARE.....	35
Device Management.....	36
Settings.....	38

---

Measurements.....	39
Data Analysis.....	41
My Devices.....	41
Upgrades.....	41
Software upgrading.....	42
Setting procedure.....	44
GENERAL SETTINGS.....	45
Description and Location.....	45
Average interval.....	45
Language.....	45
Currency.....	45
Temperature unit.....	45
Date format.....	45
Date and Time.....	46
Time Synchronization Source.....	46
Time Zone.....	47
Auto Summer/Winter Time.....	47
Maximum Demand (MD) Calculation.....	47
Maximum Demand Reset Mode.....	49
Min/Max Reset Mode.....	50
Starting Current for PF and PA (mA).....	50
Starting current for all powers (mA).....	50
Starting voltage for all Powers (V).....	50
Starting voltage for SYNC.....	50
Harmonics calculation.....	50
Reactive power & energy calculation.....	51
LCD navigation.....	51
CONNECTION.....	53
Connection mode.....	53
Setting of current and voltage ratios.....	53
Neutral line Primary/Secondary current (A).....	53
Used voltage/current range (V/A).....	53
Frequency nominal value (Hz).....	53
Max. demand current for TDD (A).....	53
Wrong connection warning.....	53
Energy flow direction.....	54
CT connection.....	54
LCD navigation.....	54
COMMUNICATION.....	55
USB Communication.....	55

Ethernet communication .....	55
MAC Address .....	55
Device Address .....	55
Firmware version .....	55
IP Address .....	55
IP Hostname .....	56
Local port .....	56
Subnet Mask .....	57
Gateway Address .....	57
NTP Server .....	57
Communication modes .....	58
LCD navigation .....	58
DISPLAY .....	60
Contrast/Black light intensity .....	60
Saving mode (min) .....	60
Demo cycling period (sec) .....	60
Custom screen 1/2/3 .....	60
LCD navigation .....	61
SECURITY .....	62
Password - Level 0 >PL0) .....	62
Password - Level 1 >PL1) .....	62
Password - Level 2 >PL2) .....	62
A Backup Password->BP) .....	62
Password lock time >min) .....	62
Password setting .....	62
Password modification .....	62
Password disabling .....	62
Password and language .....	63
LCD navigation .....	63
ENERGY .....	65
Active Tariff .....	65
Common Energy Counter Resolution .....	65
Common Energy Cost Exponent .....	65
Counter divider .....	65
Common Tariff Price Exponent .....	65
1 kWh Price in Tariff (1,2,3,4) .....	66
1 kvarh Price in Tariff (1,2,3,4) .....	66
1 kVAh Price in Tariff (1,2,3,4) .....	66
LED Energy Counter .....	66
LED Number of pulses .....	66

LED Pulse Length (ms).....	66
Measured Energy .....	66
Individual counter Resolution .....	66
Tariff Selector .....	66
Tariff Clock .....	67
Holidays/Holiday date 1-20.....	68
LCD navigation .....	68
<b>INPUTS AND OUTPUTS .....</b>	<b>70</b>
Options for I/O module 1 and 2 .....	70
Options for I/O module 3 and 4: .....	70
Auxiliary I/O Modules A & B.....	73
RTC Synchronization Module C.....	74
LCD navigation .....	76
<b>ALARMS .....</b>	<b>77</b>
Alarm statistics reset.....	77
Alarms group settings.....	79
<b>ADVANCED RECORDERS.....</b>	<b>81</b>
Logical Inputs and Logical Functions.....	81
Triggers.....	84
Recorders .....	102
<b>CONFORMITY OF VOLTAGE WITH EN 50160 STANDARD .....</b>	<b>114</b>
General PQ settings.....	114
EN 50160 parameters settings .....	117
<b>RESET.....</b>	<b>119</b>
LCD navigation .....	120
<b>MEASUREMENTS .....</b>	<b>121</b>
ONLINE MEASUREMENTS.....	121
WEB SERVER.....	122
INTERACTIVE INSTRUMENT .....	123
SUPPORTED MEASUREMENTS .....	123
AVAILABLE CONNECTIONS.....	124
SELECTION OF AVAILABLE QUANTITIES.....	124
<b>EXPLANATION OF BASIC CONCEPTS .....</b>	<b>128</b>
Sample factor $M_v$ .....	128
Average interval MP.....	128
Sample frequency .....	128
Average interval.....	128
Average interval for measurements and display.....	128

Average interval for min/max values .....	128
Average (storage) interval for recorders.....	128
Average (aggregation) interval for PQ parameters.....	129
Power and energy flow .....	129
CALCULATION AND DISPLAY OF MEASUREMENTS .....	130
KEYBOARD AND LCD (M365B) DISPLAY PRESENTATION.....	130
KEYBOARD AND TFT (M365A) DISPLAY PRESENTATION.....	130
MEASUREMENTS MENU ORGANIZATION .....	132
MEASUREMENTS MENU M365B .....	132
MEASUREMENTS MENU M365A .....	133
PRESENT VALUES .....	135
PRESENT VALUES ON LCD AND TFT DISPLAY .....	135
Voltage.....	135
Current.....	136
Active, reactive and apparent power.....	136
Power factor and power angle .....	136
Frequency .....	137
Energy counters.....	137
MD values.....	137
Harmonic distortion.....	137
Harmonic distortion parameters.....	137
Flicker evaluation .....	138
Flicker.....	138
Customized screens.....	139
MIN/MAX VALUES .....	140
Average interval for min/max values.....	140
Display of min/max values on M365B.....	140
Display of min/max values on M365A.....	140
Display of min/max values – QDSP2.1 software .....	141
ALARMS.....	142
SURVEY OF ALARMS .....	144
DEMO CYCLING .....	145
HARMONIC ANALYSIS .....	145
Display of harmonic parameters.....	146
Harmonic analysis – QDSP2.1 .....	148
PQ ANALYSIS .....	150
LCD navigation .....	159
PQDIF AND COMTRADE FILES ON M365A/M365B – CONCEPT DESCRIPTION .....	161

---

WORKING WITH PQDIF AND COMTRADE FILES ON THE DEVICE.....	161
Accessing PQDIF files.....	161
Accessing COMTRADE files.....	167
PQDiffactor - PQDIF and COMTRADE file viewer.....	169
<b>TECHNICAL DATA .....</b>	<b>170</b>
ACCURACY.....	170
MEASUREMENT INPUTS.....	172
CONNECTION.....	173
Connection table.....	173
COMMUNICATION.....	173
INPUT/OUTPUT MODULES.....	175
SAFETY.....	178
TIME SYNCHRONIZATION INPUT.....	178
AUXILIARY POWER SUPPLY.....	178
MECHANICAL.....	179
AMBIENT CONDITIONS.....	179
REAL TIME CLOCK.....	180
OPERATING CONDITIONS.....	180
DIMENSIONS.....	181
<b>APPENDICES .....</b>	<b>182</b>
APPENDIX A: MODBUS COMMUNICATION PROTOCOL.....	182
APPENDIX B: DNP3 COMMUNICATION PROTOCOL.....	192
APPENDIX C: EQUATIONS.....	199
APPENDIX D: PQDIF AND COMTRADE RECORDER DATA STORAGE ORGANIZATION.....	204
APPENDIX E: IEC61850 ED.2 PROTOCOL SUPPORT OVERVIEW.....	207
APPENDIX F: CORTEC.....	214

# ISTAT M365A/M365B

M365A





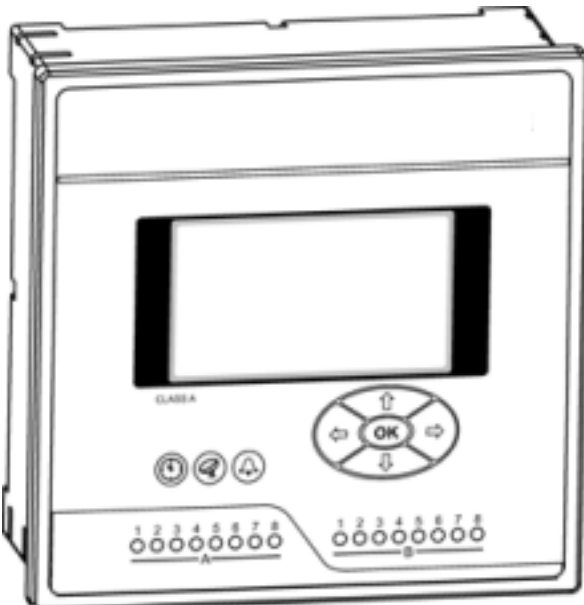

M365B



# WARNINGS, INFORMATION AND NOTES

Used symbols:

	See ISTAT M365A/M365B documentation.
	Double insulation in compliance with the EN 61010–1 standard.
	Functional ground potential. Note: This symbol is also used for marking a terminal for protective ground potential if it is used as a part of connection terminal or auxiliary supply terminals.
	Compliance of the product with directive 2002/96/EC, as first priority, the prevention of waste electrical and electronic equipment (WEEE), and in addition, the reuse, recycling and other forms of recovery of such wastes so as to reduce the disposal of waste. It also seeks to improve the environmental performance of all operators involved in the life cycle of electrical and electronic equipment.
	Compliance of the product with European CE directives.

# BEFORE SWITCHING THE DEVICE ON

Check the following before switching on the ISTAT M365A/M365B:

- Nominal voltage,
- Supply voltage,
- Nominal frequency,
- Voltage ratio and phase sequence,
- Current transformer ratio and terminals integrity,
- Protection fuse for voltage inputs (recommended maximal external fuse size is 6 A)
- External switch or circuit-breaker must be included in the installation for disconnection of the devices' aux. power supply. It must be suitably located and properly marked for reliable disconnection of the device when needed.
- Integrity of earth terminal
- Proper connection and voltage level of I/O modules

Important: A current transformer secondary should be short circuited before connecting the ISTAT M365A/M365B.

# DEVICE SWITCH OFF WARNING

Auxiliary supply circuits for (external) relays can include capacitors between supply and ground. In order to prevent electrical shock hazard, the capacitors should be discharged via external terminals after having completely disconnected auxiliary supply (both poles of any DC supply).

# HEALTH AND SAFETY

The purpose of this chapter is to provide a user with information on safe installation and handling with the ISTAT M365A/M365B in order to assure its correct use and continuous operation.

We expect that everyone using the product will be familiar with the contents of chapter » WARNINGS, INFORMATION AND NOTES «.

If equipment is used in a manner not specified by the manufacturer, the protection provided by the equipment may be impaired.

# REAL TIME CLOCK

As a backup power supply for Real time clock super-cap is built in. Support time is up to 2 days (after each power supply down).

# DISPOSAL

It is strongly recommended that electrical and electronic equipment is not deposit as municipal waste. The manufacturer or provider shall take waste electrical and electronic equipment free of charge. The complete procedure after lifetime should comply with the Directive 2002/96/EC about restriction on the use of certain hazardous substances in electrical and electronic equipment.

# BASIC DESCRIPTION AND OPERATION

This chapter presents all relevant information about the ISTAT M365A/M365B required to understand its purpose, applicability and basic features related to its operation.

Apart from this, it also contains navigational tips, description of used symbols and other useful information for understandable navigation through this manual.

Regarding the options of this ISTAT M365A/M365B, different chapters should be considered since a particular sub variant might vary in functionality. More detailed description of ISTAT M365A/M365B functions is given in chapters Main Features, Supported options and Functionality.

ISTAT M365A/M365B is available in 144mmx144mm panel mounting enclosure.

Specifications of housing and panel cut out for housing is specified in chapter.

---

## Contents

Packaging contains the following items:

- ISTAT M365A/M365B
- Fixing screws
- Pluggable terminals for connection of inputs, aux. Power supply and I/O modules
- Quick installation guide

All related product documentation and QDSP2.1 setup software can be found at [www.gegridsolutions.com](http://www.gegridsolutions.com) or obtained via our Contact Centre.

### CAUTION

Please examine the equipment carefully for potential damage which might have occurred during transport.

---

## Description of the ISTAT M365A/M365B

### M365A

Power Quality Analyzer M365A is a comprehensive device intended for permanent monitoring of power quality from its production, transmission, distribution all the way to the final consumers, who are most affected by inadequate voltage quality. It is mostly applicable in medium and low voltage applications.

Lack of information regarding supplied voltage quality can lead to unexplained production problems and malfunction or can even damage equipment being used during factory production process. Therefore, this device can be used for the needs of electrical utilities (evaluation against standards) as well as for industrial purposes (e.g. for monitoring the level of supplied power quality).

#### Appearance

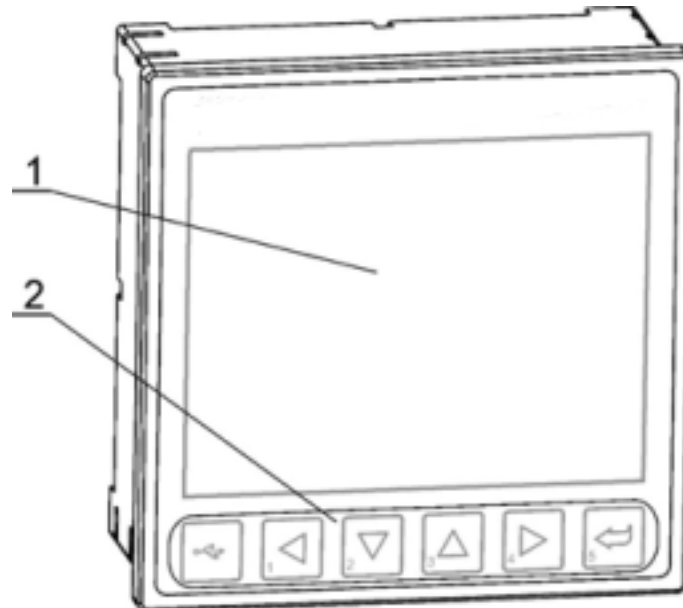

#### 1 Color TFT display:

5.7 inch color TFT display is used for displaying measuring quantities and for a display of selected functions when setting the Power Quality Analyzer M365A.

#### 2 Navigation keyboard:

The "Enter" key is used for confirming/selecting the settings. Direction keys are used for navigating between screens and menus. Function of individual key may vary depending on the selected screen.

## M365B

Power Quality Analyzer M365B is a comprehensive device intended for permanent monitoring of power quality from its production, transmission, distribution all the way to the final consumers, who are most affected by inadequate voltage quality. It is mostly applicable in medium and low voltage applications.

Lack of information regarding supplied voltage quality can lead to unexplained production problems and malfunction or can even damage equipment being used during factory production process. Therefore, this device can be used for the needs of electrical utilities (evaluation against standards) as well as for industrial purposes (e.g. for monitoring the level of supplied power quality).

Appearance

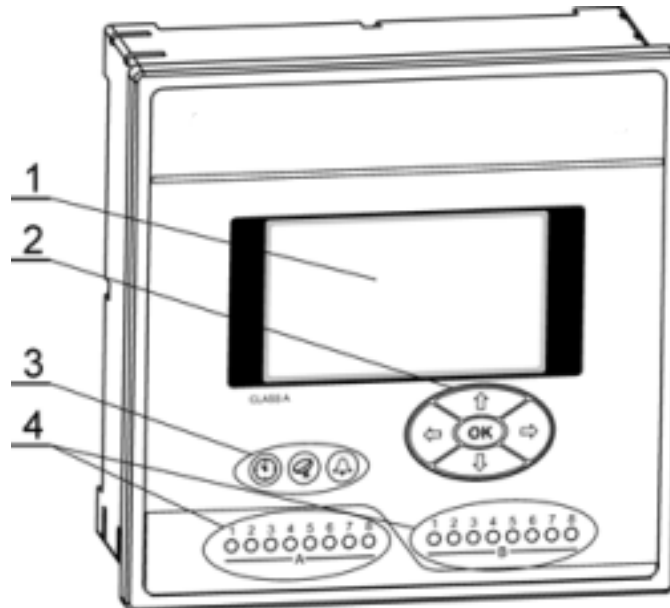

### 1 Graphical LCD:

A graphical LCD with back-light is used for displaying measuring quantities and for a display of selected functions when setting the Power Quality Analyzer M365B.

### 2 Navigation keyboard:

The "OK" key is used for confirming the settings, selecting and exiting the display. Direction keys are used for shifting between screens and menus.

### 3 LED indicators:

There are two types of LED indicators positioned on the front panel. General operation LED indicators and I/O status LED indicators.

General operation LED indicators warn on certain device status. The left-most (red) indicator indicates that the device internal clock is synchronized (via GPS, IRIG-B or NTP protocol). The middle (green) one is blinking when transmitting MC data via communication to the server. The right-most (red) one is blinking when any of the alarm conditions is fulfilled.

I/O state LED indicators are in operation when additional Modules A and/or B are built-in. These modules can have the functionality of Digital input or Relay output. They are indicating the state of a single I/O. Red LED is lit in either of the following conditions:

- Relay output is activated
- Signal is present on Digital input

## Abbreviation/Glossary

Abbreviations are explained within the text where they appear the first time. Most common abbreviations and expressions are explained in the following table:

Term	Explanation
RMS	Root Mean Square value
Flash	Type of a memory module that keeps its content in case of power supply failure
Ethernet	IEEE 802.3 data layer protocol
MODBUS / DNP3	Industrial protocol for data transmission
Memory card	Multimedia memory card. Type MMC and SD supported.
QDSP2.1	Setting Software for GE Vernova instruments
PA total	Power Angle calculated from total active and apparent power
PA <sub>phase</sub>	Angle between fundamental phase voltage and phase current
PF <sub>phase</sub>	Power factor, calculated from apparent and active power (affected by harmonics)
THD (U, I)	Total harmonic distortion
TDD (I)	Total demand distortion (according to IEEE Std. 519-1992). Indicates harmonic distortion at full load.
K factor (I)	Indicates a weighting of the harmonic load currents according to their effects on transformer heating. (according to IEEE C57.110)
CREST factor (I)	Indicates a ratio between the peak amplitude of the waveform and the RMS value of the waveform.
MD	Max. Demand; Measurement of average values in time interval
FFT graphs	Graphical display of presence of harmonics
Harmonic voltage – harmonic	Sine voltage with frequency equal to integer multiple of basic frequency
InterHarmonic voltage – interharmonics	Sine voltage with frequency NOT equal to integer multiple of basic frequency
Flicker	Voltage fluctuation causes changes of luminous intensity of lamps, which causes the so-called flicker
RTC	Real Time Clock
Sample factor	Defines a number of periods for measuring calculation on the basis of measured frequency
M <sub>p</sub> – Average interval	Defines frequency of refreshing displayed measurements
Hysteresis [%]	Percentage specifies increase or decrease of a measurement from a certain limit after exceeding it.
IRIG-B	Serial Inter-range instrumentation group time code
GPS	Satellite navigation and time synchronization system
PO	Pulse output module
TI	Tariff input module
RO	Relay output module
BO	Bistable alarm output module
AO	Analogue output module
DI	Digital input module
PI	Pulse input module
AI	Analogue input module
WO	Status (watchdog) module – for supervision of proper operation
PQDIF	Power Quality Data Interchange Format, which is a binary file format (according to IEEE Std 1159.3-2003) that is used to exchange power quality data among different SW products.
COMTRADE	Common format for Transient Data Exchange for power systems is a file format for storing oscillography and status data related to transient power system disturbances.
Waveform	Represents the detailed time-dependent shape and form of a voltage, current or logical input signal
Transient	Represents power quality disturbances that involve destructive high magnitudes of current and voltage or even both. They exist in a very short duration from less than 50 nanoseconds to as long as 50 milliseconds.
Disturbance	These are used for monitoring long-term disturbances. Every half/full cycle, RMS value is calculated, based on the previous cycle.
PQ	Power Quality

List of common abbreviations and expressions

## Purpose and use of the ISTAT M365A/M365B

ISTAT M365A/M365B performs measurements in compliance with regulatory requested standard EN 61000-4-30 and evaluates recorded parameters for analysis according to parameters defined in European power quality standard EN50160. It enables storage of a wide variety of highly detailed oscillography data in 8GB of internal flash memory based on a sophisticated trigger settings mechanism. Data can be stored in standardized PQDIF (IEEE 1159-3) and COMTRADE (IEEE C37.111) file formats which can easily be exchanged with third party PQ analysis SW systems.

Moreover ISTAT M365A/M365B stores measurements and quality reports in internal memory for further analysis. By accessing recorded or real time values from multiple instruments installed on different locations it is possible to gain the overall picture of the complete systems' behavior. This can be achieved with regard to ISTAT M365A/M365B accurate internal real time clock and wide range of synchronization sources support, which assure accurate, time-stamped measurements from dislocated units.

Stored data can then be transferred to a PC or server for post analysis. The simplest way this is done is by directly connecting a PC with installed QDSP2.1 Setting Studio SW via USB cable. To save server space high precision data can also be transferred from a selected device on-demand using FTP.

The following characteristics are measured and recorded:

Monitored Power Quality indices as defined by EN 50160

Phenomena	PQ Parameters
Frequency variations	Frequency distortion
Voltage variations	Voltage fluctuation
	Voltage unbalance
Voltage changes	Rapid voltage changes
	Flicker
Voltage events	Voltage dips
	Voltage interruptions
	Voltage swells
Harmonics & THD	THD
	Harmonics
	Inter-harmonics
	Signaling voltage

## **ISTAT M365A/M365B application and benefits**

ISTAT M365A/M365B can be used as a standalone PQ monitoring device for detection and analysis of local PQ deviations, transients, alarms and periodic measurements. For this purpose it is normally positioned at the point-of-common-coupling (PCC) of industrial and commercial energy consumers to monitor quality of delivered electric energy or at medium or low voltage feeders to monitor, detect and record possible disturbances caused by operation of consumers.

Identifying relevant fixed measuring points is the most important task prior to complete system installation. The implementation of a PQ system itself will not prevent disturbances in network but rather help diagnose their origins and effects by comparing and scrutinizing data from multiple time synchronized measurement points.

## Main Features, supported options and functionality of ISTAT M365A/M365B

ISTAT M365A/M365B is a perfect tool for monitoring and analyzing medium or low voltage systems in power distribution and industrial segments. It can be used as a standalone PQ monitoring device for detection of local PQ deviations. For this purpose it is normally positioned at the point-of-common-coupling (PCC) of small and medium industrial and commercial energy consumers to monitor quality of delivered electric energy or at medium or low voltage feeders to monitor, detect and record possible disturbances caused by (unauthorized) operation of consumers.

User can select different hardware modules that can be implemented in device. Wide range of variants can cover practically every user's requirements.

ISTAT M365A/M365B is a compact, user friendly and cost effective device that offers various features to suit most of the requirements for a demanding power system management:

- Evaluation of the electricity supply quality in compliance with EN50160 with automatic report generation
- Class A (0.1%) accuracy in compliance with EN61000-4-30 Ed.3
- Instantaneous evaluation of over 700 electrical measurement quantities values including PQ related parameters, harmonics (voltage/current THDs, TDDs, up to 63rd voltage(PP, PN)/current harmonics and inter-harmonics)
- Automatic range selection of 4 current and 4 voltage channels (max. 12.5 A and 1000 VRMS) with 32 kHz sampling rate
- Oscillography capability for recording waveforms with up to 625 samples/cycle sampling frequency
- Recording of disturbance, trend and Power Quality (PQ) events in trigger related recorders
- All trigger related recorder data available on-demand through FTP
- A sophisticated triggering mechanism to register and record events of various nature:
  - Current and voltage transient event generated triggers based on hold-off time (in ms), absolute peak value (in % of Un) and fast change (in %Un/ $\mu$ s)
  - PQ event generated triggers based on the following events: voltage dip, voltage swell, voltage interruption, end of voltage interruption, rapid voltage change and inrush current
  - External Ethernet triggers enabling trigger events with up to 8 different devices within the network
  - External Digital triggers based on logical/digital inputs
  - Up to 16 combined triggers enabling logical operation on previously configured triggers of various nature
- Recording a wide variety of data in the internal device 8GB flash memory based on trigger settings:
  - All activated triggers together with timestamp, duration, condition as well as a reference to an (optionally) generated transient, waveform, disturbance and fast trend record
  - Waveform recorder with PQDIF/COMTRADE data format selection, selectable recorded channels (4xVoltage, 4xCurrent, 16xDigital input), 19 samples/cycle to 625 samples/cycle resolution, pre-trigger time from 0,01s up to 1s, post-trigger time from 0,01s up to 40s (20s for 625 samples/cycle)
  - Disturbance recorder with PQDIF/COMTRADE data format selection, selectable recorded channels (4xP-N Voltage, 3xP-P Voltage, 4xCurrent, 8xLogical inputs), half/full cycle averaging interval, pre-trigger time up to 3000 cycles, post trigger time up to 60000 cycles
  - Periodic measurements in 4 standard trend recorders A through D each containing up to 32 arbitrarily evaluated (maximum, minimum, average, maximum demand, minimum demand, actual) quantities with periods ranging from 1min to 60min
  - Periodic measurements in advanced fast trend recorders 1 through 4 each containing over 700 arbitrarily evaluated (maximum, minimum, average, actual) quantities with periods ranging from 1s to 60min. The recorder can be set to PQDIF data format selection
  - 32 adjustable alarms in 4 alarm groups each containing up to 8 alarms. Alarms relate to a particular quantity over/under threshold and serve the purpose of controlling on-device relay outputs as well as informing the server about the occurrence of alarm events
  - Recording and on-board evaluation of PQ anomalies and PQ reports based on EN50160
- Four quadrant energy measurement in 8 programmable counters with class 0.2S accuracy with up to four tariffs and an advanced tariff clock. Every Counters' resolution and range can be defined. The counter content can be configured as:
  - Active energy (Wh) import

- Active energy (Wh) export
  - Reactive energy (varh) import
  - Reactive energy (varh) export
  - Total absolute active energy (Wh)
  - Total absolute reactive energy (varh)
  - Total absolute apparent energy (VAh)
  - Custom settings (phase dependent, four quadrant – P/Q/import/export selection)
- Automatic range selection of 4 current and 4 voltage channels (max. 12.5 A and 1000 VRMS) with 32 kHz sampling rate
  - Measurements of 40 minimal and maximal values in different time intervals (from 1 to 256 periods)
  - Frequency range from 16 Hz to 400 Hz
  - Ethernet and USB 2.0 communication support
  - Communication - MODBUS, DNP3, FTP, upgradeable to EN61850 Ed.2 (optionally – see Appendix E)
  - Support for GPS, IRIG-B (modulated and digital) and NTP real time clock synchronization
  - Up to 4 inputs/outputs on I/O module 1/2 and 3/4 (analogue inputs/outputs, digital inputs/outputs, alarm/watchdog outputs, pulse input/outputs, tariff inputs, bistable alarm outputs, relay output)
  - Up to 20 inputs/outputs on I/O module A and B (relay output, digital input)
  - QDSP2.1 Setting studio User-friendly setting and analysis software with FTP communication feasibility for seamless device settings and single device advanced analysis
  - On-board Web server support for basic measurement overview
  - Multilingual support (M365B only)
  - Auxiliary power supply
  - 144 mm square panel mounting
  - Available with:
    - 5.7 inch color TFT display (M365A)
    - 128x64 pixel display (M365B)

General hardware Features	Default / Optional
<b>General</b>	
Class A measuring accuracy (0.1%) according to EN 61000-4-30 Ed.3	●
Voltage auto range up to 1000Vp-p <sub>RMS</sub>	●
Current auto range up to 12.5 A	●
4 voltage and 4 current channels with 32 us sampling time	●
Auxiliary power supply	●
Two independent communication ports (see data below)	○
Support for GPS / IRIG-B / NTP real time synchronization	● / ● / ●
Up to 20 additional inputs and outputs (see data below)	○
Internal flash memory (8MB+8GB)	●
Real time clock (RTC)	●
standard 144 mm DIN square panel mounting	●
<b>Front panel</b>	
Graphical LCD display with back light – M365B	●
LED indicator (sync/com./alarm) – M365B	●
I/O status LED indicator – M365B	●
Control keys on front panel (5 keys)	●
<b>Communication</b>	
COM1: Ethernet +USB	●
COM2: Serial (RS232/ RS485 on slot C if other synchronization modes are in use)	●
<b>Input and output modules</b>	
<b>Input / output module 1</b>	
2×AO / 2×AI / 2×RO / 2×PO / 2×PI / 2×TI / 1×BO / 2×DI / WO+RO	○/○○○○○○○○○○
<b>Input / output module 2</b>	
2×AO / 2×AI / 2×RO / 2×PO / 2×PI / 2×TI / 1×BO / 2×DI / WO+RO	○/○○○○○○○○○○
<b>Auxiliary input / output module A</b>	
I/O A   (1-8) DI / RO	○ / ○
<b>Auxiliary input / output module B</b>	
I/O B   (1-8) DI	○
<b>Synchronization module C</b>	
I/O C   GPS + 1pps / IRIG-B / COM2	● / ● / ●

- Function is supported (default)
- Optional (to be specified with an order)

PO	Pulse output module
TI	Tariff input module
RO	Relay output module
BO	Bistable relay output module
AO	Analogue output module
DI	Digital input module
PI	Pulse input module
AI	Analogue input module – U, I or R (PT100/1000)
WO	Status (watchdog) module – for supervision of proper operation

General hardware Features	Default / Optional
EN 50160 power quality evaluation	●
Automatic PQ report generation	●
Disturbance, trend & PQ event recording	●
Waveform recorder with programmable sampling time (max 625 samples / cycle)	●
Standardized PQDIF and COMTRADE format support	●
QDSP2.1 user friendly setting & analysis software	●
Setup wizard	●
Wrong connection warning	●
Custom screen settings (3 user defined screens on LCD)	●
Demonstration screen cycling	●
Programmable refresh time	●
MODBUS and DNP3 communication protocols	●
Tariff clock	●
MD calculation (TF, FW, SW)	●
Wide frequency measurement range 16 – 400 Hz	●
Programmable alarms (32 alarms)	●
Alarms recording	●
Measurements recording (128 quantities)	●
Measurements graphs (time / FFT)	●
Evaluation of voltage quality in compliance with EN 50160	●
Real time clock synchronization (GPS/IRIG-B/NTP)	●
5.7 inch color TFT display (M365A)	○
EN61850 Ed.2 Server	○

- Function is supported (default)
- Optional (to be specified with an order)

# CONNECTION

This chapter deals with the instructions for measuring instrument connection. Both the use and connection of the ISTAT M365A/M365B includes handling with dangerous currents and voltages. Connection shall therefore be performed ONLY a by a qualified person using an appropriate equipment. GE Vernova does not take any responsibility regarding the use and connection. If any doubt occurs regarding connection and use in the system which device is intended for, please contact a person who is responsible for such installations.

A person qualified for installation and connection of a device should be familiar with all necessary precaution measures described in this document prior to its connection.

Before use please check the following:

- Nominal voltage ( $U_{P-Pmax} = 1000V_{ACrms}$ ;  $U_{P-Nmax} = 600V_{ACrms}$ ),
- Supply voltage (rated value),
- Nominal frequency,
- Voltage ratio and phase sequence,
- Current transformer ratio and terminals integrity,
- Protection fuse for voltage inputs (recommended maximal external fuse size is 6 A)
- External switch or circuit-breaker must be included in the installation for disconnection of the devices' aux. power supply. It must be suitably located and properly marked for reliable disconnection of the device when needed. See CAUTION below.
- Integrity of earth terminal
- Proper connection and voltage level of I/O modules

## WARNING

Wrong or incomplete connection of voltage or other terminals can cause non-operation or damage to ISTAT M365A/M365B.

## WARNING

It is imperative that terminal 12 which represents fourth voltage measurement channel is connected to earth pole ONLY. This terminal should be connected to EARTH potential at all times! This input channel is used only for measuring voltage between neutral end earth line.

## CAUTION

Aux. Supply inrush current can be as high as 20A for short period of time (<1 ms). Please choose an appropriate MCB for disconnection of aux. supply.

## PLEASE NOTE

After connection, settings have to be performed via a keyboard on the front side of the device that reflects connection of device to voltage network (connection mode, current and voltage transformers ratio ...). Settings can also be done via communication or a memory card (where available).

## Mounting

ISTAT M365A/M365B is intended only for panel mounting. Pluggable connection terminals allow easier installation and quick replacement should that be required.

This device is not intended for usage as portable equipment and should be used only as a fixed panel mounted device.

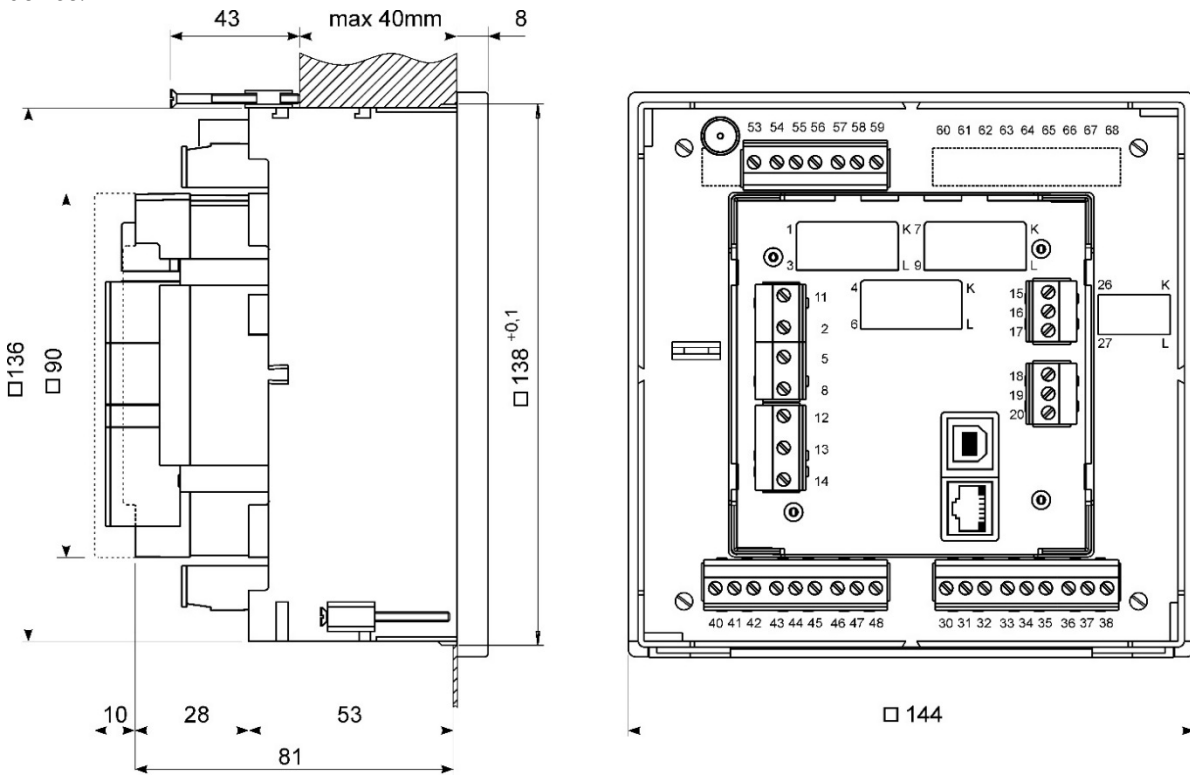

Dimensional drawing and rear connection terminals position

Recommended panel cut out is:

138 x 138 mm + 0.8

Please remove protection foil from the screen.

## Electrical connection for ISTAT M365A/M365B

Voltage inputs of ISTAT M365A/M365B can be connected directly to low-voltage network or via a voltage measuring transformer to a high-voltage network.

Current inputs of a device are led through a hole in current transformers to allow uninterrupted current connection. Connection to network is performed via a corresponding current transformer.

Choose corresponding connection from the figures below and connect corresponding voltages and currents. Information on electrical consumption of current and voltage inputs is given in a chapter Technical Data.

### CAUTION

For accurate operation and to avoid measuring signal crosstalk it is important to avoid driving voltage measuring wires close to current measuring transformers.

#### System/ connection

#### Terminal assignment

Connection 1b (1W)  
Single phase connection

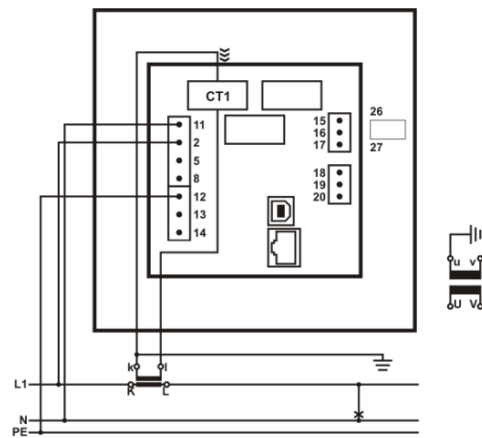

Connection 3b (1W3b)  
Three phase, three wire connection  
with balanced load

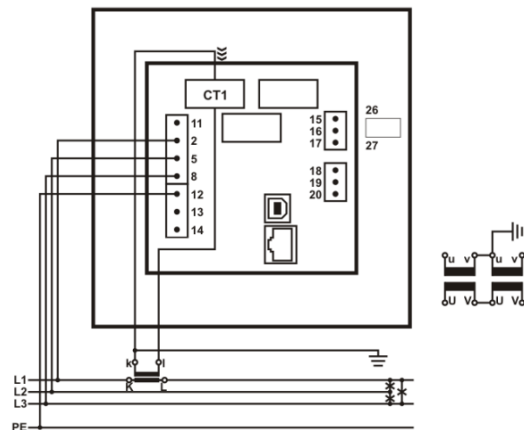

System/ connection

Terminal assignment

Connection 3u (2W3u)  
 Three phase, three wire connection  
 with unbalanced load

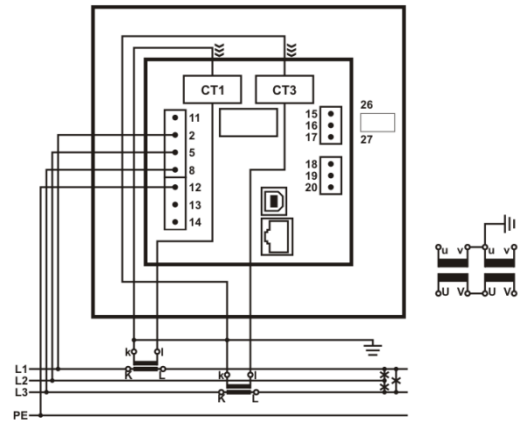

Connection 4b (1W4b)  
 Three phase, four wire connection  
 with balanced load

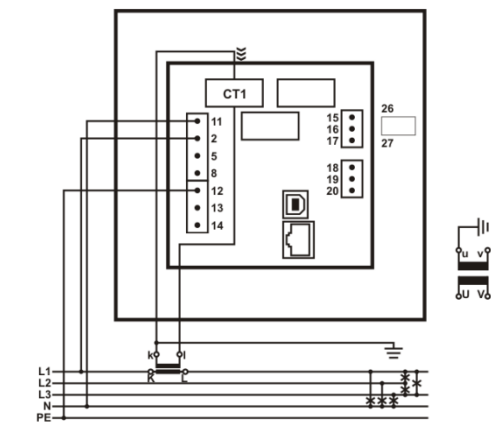

Connection 4u (3W4u)  
 Three phase, four wire connection  
 with unbalanced load

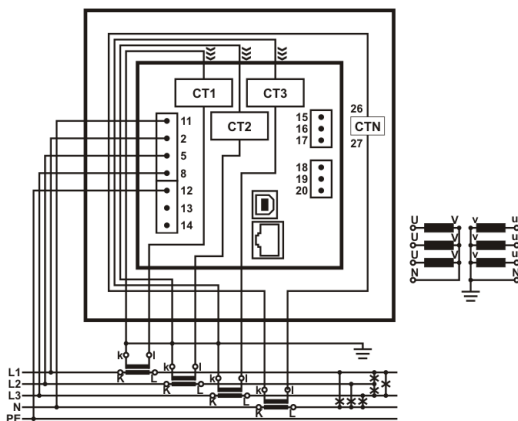

**PLEASE NOTE**

With all connection schemes must be terminal 12 (PE) ALWAYS connected. Fourth voltage channel is dedicated for measuring voltage between EARTH (PE, terminal 12) and NEUTRAL (N, terminal 11).

## Connection of input/output modules

### WARNING

Check the module features that are specified on the label, before connecting module contacts. Wrong connection can cause damage or destruction of module and/or device.

### PLEASE NOTE

Examples of connections are given for device with built in two input/output modules and Ethernet/USB communication. Connection does not depend on a number of built-in modules and communication, and is shown on the devices' label.

Connect module contacts as specified on the label. Examples of labels are given below and describe modules built in the device. Information on electrical properties of modules is given in a chapter Technical Data – Input/output modules.

### I/O module 1/2 and 3/4 (terminal numbers 15-20)

<table border="1"> <thead> <tr> <th colspan="2">I/O 1/2</th> </tr> </thead> <tbody> <tr> <td colspan="2">2 x Analogue output</td> </tr> <tr> <td>0...20 mA</td> <td>1+ 15</td> </tr> <tr> <td></td> <td>2- 16</td> </tr> <tr> <td>R<sub>max</sub>=150 Ω</td> <td>2+ 17</td> </tr> </tbody> </table>	I/O 1/2		2 x Analogue output		0...20 mA	1+ 15		2- 16	R <sub>max</sub> =150 Ω	2+ 17	<table border="1"> <thead> <tr> <th colspan="2">I/O 3/4</th> </tr> </thead> <tbody> <tr> <td colspan="2">2 x Analogue output</td> </tr> <tr> <td>0...20 mA</td> <td>3+ 18</td> </tr> <tr> <td></td> <td>4- 19</td> </tr> <tr> <td>R<sub>max</sub>=150 Ω</td> <td>4+ 20</td> </tr> </tbody> </table>	I/O 3/4		2 x Analogue output		0...20 mA	3+ 18		4- 19	R <sub>max</sub> =150 Ω	4+ 20	Analogue output module with two analogue outputs (0...20mA), proportional to measured quantities.
I/O 1/2																						
2 x Analogue output																						
0...20 mA	1+ 15																					
	2- 16																					
R <sub>max</sub> =150 Ω	2+ 17																					
I/O 3/4																						
2 x Analogue output																						
0...20 mA	3+ 18																					
	4- 19																					
R <sub>max</sub> =150 Ω	4+ 20																					
<table border="1"> <thead> <tr> <th colspan="2">I/O 1/2</th> </tr> </thead> <tbody> <tr> <td colspan="2">2 x Pulse output</td> </tr> <tr> <td>40 V DC/AC</td> <td>1+ 15</td> </tr> <tr> <td>30 mA</td> <td>2- 16</td> </tr> <tr> <td></td> <td>2+ 17</td> </tr> </tbody> </table>	I/O 1/2		2 x Pulse output		40 V DC/AC	1+ 15	30 mA	2- 16		2+ 17	<table border="1"> <thead> <tr> <th colspan="2">I/O 3/4</th> </tr> </thead> <tbody> <tr> <td colspan="2">2 x Pulse output</td> </tr> <tr> <td>40 V DC/AC</td> <td>3+ 18</td> </tr> <tr> <td>30 mA</td> <td>4- 19</td> </tr> <tr> <td></td> <td>4+ 20</td> </tr> </tbody> </table>	I/O 3/4		2 x Pulse output		40 V DC/AC	3+ 18	30 mA	4- 19		4+ 20	Pulse output (solid state) module with two pulse outputs for energy counters.
I/O 1/2																						
2 x Pulse output																						
40 V DC/AC	1+ 15																					
30 mA	2- 16																					
	2+ 17																					
I/O 3/4																						
2 x Pulse output																						
40 V DC/AC	3+ 18																					
30 mA	4- 19																					
	4+ 20																					
<table border="1"> <thead> <tr> <th colspan="2">I/O 1/2</th> </tr> </thead> <tbody> <tr> <td colspan="2">2 x Relay output</td> </tr> <tr> <td>35 V DC</td> <td>1+ 15</td> </tr> <tr> <td>40 V AC</td> <td>2- 16</td> </tr> <tr> <td>1000 mA</td> <td>2+ 17</td> </tr> </tbody> </table>	I/O 1/2		2 x Relay output		35 V DC	1+ 15	40 V AC	2- 16	1000 mA	2+ 17	<table border="1"> <thead> <tr> <th colspan="2">I/O 3/4</th> </tr> </thead> <tbody> <tr> <td colspan="2">2 x Relay output</td> </tr> <tr> <td>35 V DC</td> <td>3+ 18</td> </tr> <tr> <td>40 V AC</td> <td>4- 19</td> </tr> <tr> <td>1000 mA</td> <td>4+ 20</td> </tr> </tbody> </table>	I/O 3/4		2 x Relay output		35 V DC	3+ 18	40 V AC	4- 19	1000 mA	4+ 20	Relay output module with two outputs.
I/O 1/2																						
2 x Relay output																						
35 V DC	1+ 15																					
40 V AC	2- 16																					
1000 mA	2+ 17																					
I/O 3/4																						
2 x Relay output																						
35 V DC	3+ 18																					
40 V AC	4- 19																					
1000 mA	4+ 20																					
<table border="1"> <thead> <tr> <th colspan="2">I/O 1/2</th> </tr> </thead> <tbody> <tr> <td colspan="2">Bistable al. output</td> </tr> <tr> <td>35 V DC</td> <td>+ 15</td> </tr> <tr> <td>40 V AC</td> <td>- 16</td> </tr> <tr> <td>1000 mA</td> <td>+ 17</td> </tr> </tbody> </table>	I/O 1/2		Bistable al. output		35 V DC	+ 15	40 V AC	- 16	1000 mA	+ 17	<table border="1"> <thead> <tr> <th colspan="2">I/O 3/4</th> </tr> </thead> <tbody> <tr> <td colspan="2">Bistable al. output</td> </tr> <tr> <td>35 V DC</td> <td>+ 18</td> </tr> <tr> <td>40 V AC</td> <td>- 19</td> </tr> <tr> <td>1000 mA</td> <td>+ 20</td> </tr> </tbody> </table>	I/O 3/4		Bistable al. output		35 V DC	+ 18	40 V AC	- 19	1000 mA	+ 20	Bistable alarm output module; keeps the state also in case of device power supply failure.
I/O 1/2																						
Bistable al. output																						
35 V DC	+ 15																					
40 V AC	- 16																					
1000 mA	+ 17																					
I/O 3/4																						
Bistable al. output																						
35 V DC	+ 18																					
40 V AC	- 19																					
1000 mA	+ 20																					
<table border="1"> <thead> <tr> <th colspan="2">I/O 1/2</th> </tr> </thead> <tbody> <tr> <td colspan="2">2 x Analogue input</td> </tr> <tr> <td>-20...0...20 mA</td> <td>1+ 15</td> </tr> <tr> <td></td> <td>2- 16</td> </tr> <tr> <td></td> <td>2+ 17</td> </tr> </tbody> </table>	I/O 1/2		2 x Analogue input		-20...0...20 mA	1+ 15		2- 16		2+ 17	<table border="1"> <thead> <tr> <th colspan="2">I/O 3/4</th> </tr> </thead> <tbody> <tr> <td colspan="2">2 x Analogue input</td> </tr> <tr> <td>-20...0...20 mA</td> <td>3+ 18</td> </tr> <tr> <td></td> <td>4- 19</td> </tr> <tr> <td></td> <td>4+ 20</td> </tr> </tbody> </table>	I/O 3/4		2 x Analogue input		-20...0...20 mA	3+ 18		4- 19		4+ 20	Analogue input module enables measurements of DC I or temp. (PT100, PT1000) values from external sources. Modules have different hardware, so programming is possible within one quantity.
I/O 1/2																						
2 x Analogue input																						
-20...0...20 mA	1+ 15																					
	2- 16																					
	2+ 17																					
I/O 3/4																						
2 x Analogue input																						
-20...0...20 mA	3+ 18																					
	4- 19																					
	4+ 20																					
<table border="1"> <thead> <tr> <th colspan="2">I/O 1/2</th> </tr> </thead> <tbody> <tr> <td colspan="2">2 x Analogue input</td> </tr> <tr> <td>-10...0...10 V</td> <td>1+ 15</td> </tr> <tr> <td></td> <td>2- 16</td> </tr> <tr> <td></td> <td>2+ 17</td> </tr> </tbody> </table>	I/O 1/2		2 x Analogue input		-10...0...10 V	1+ 15		2- 16		2+ 17	<table border="1"> <thead> <tr> <th colspan="2">I/O 3/4</th> </tr> </thead> <tbody> <tr> <td colspan="2">2 x Analogue input</td> </tr> <tr> <td>-10...0...10 V</td> <td>3+ 18</td> </tr> <tr> <td></td> <td>4- 19</td> </tr> <tr> <td></td> <td>4+ 20</td> </tr> </tbody> </table>	I/O 3/4		2 x Analogue input		-10...0...10 V	3+ 18		4- 19		4+ 20	Analogue input module enables measurements of DC U or temp. (PT100, PT1000) values from external sources. Modules have different hardware, so programming is possible within one quantity.
I/O 1/2																						
2 x Analogue input																						
-10...0...10 V	1+ 15																					
	2- 16																					
	2+ 17																					
I/O 3/4																						
2 x Analogue input																						
-10...0...10 V	3+ 18																					
	4- 19																					
	4+ 20																					
<table border="1"> <thead> <tr> <th colspan="2">I/O 1/2</th> </tr> </thead> <tbody> <tr> <td colspan="2">2 x Analogue input</td> </tr> <tr> <td>0...2 kΩ</td> <td>1 15</td> </tr> <tr> <td></td> <td>2 16</td> </tr> <tr> <td></td> <td>2 17</td> </tr> </tbody> </table>	I/O 1/2		2 x Analogue input		0...2 kΩ	1 15		2 16		2 17	<table border="1"> <thead> <tr> <th colspan="2">I/O 3/4</th> </tr> </thead> <tbody> <tr> <td colspan="2">2 x Analogue input</td> </tr> <tr> <td>0...2 kΩ</td> <td>3 18</td> </tr> <tr> <td></td> <td>4 19</td> </tr> <tr> <td></td> <td>4 20</td> </tr> </tbody> </table>	I/O 3/4		2 x Analogue input		0...2 kΩ	3 18		4 19		4 20	Analogue input module enables measurements of R or temp. (PT100, PT1000) values from external sources. Modules have different hardware, so programming is possible within one quantity.
I/O 1/2																						
2 x Analogue input																						
0...2 kΩ	1 15																					
	2 16																					
	2 17																					
I/O 3/4																						
2 x Analogue input																						
0...2 kΩ	3 18																					
	4 19																					
	4 20																					
<table border="1"> <thead> <tr> <th colspan="2">I/O 1/2</th> </tr> </thead> <tbody> <tr> <td colspan="2">2 x Digital input</td> </tr> <tr> <td>230 V DC/AC</td> <td>1+ 15</td> </tr> <tr> <td>± 20%</td> <td>2- 16</td> </tr> <tr> <td></td> <td>2+ 17</td> </tr> </tbody> </table>	I/O 1/2		2 x Digital input		230 V DC/AC	1+ 15	± 20%	2- 16		2+ 17	<table border="1"> <thead> <tr> <th colspan="2">I/O 3/4</th> </tr> </thead> <tbody> <tr> <td colspan="2">2 x Digital input</td> </tr> <tr> <td>230 V DC/AC</td> <td>3+ 18</td> </tr> <tr> <td>± 20%</td> <td>4- 19</td> </tr> <tr> <td></td> <td>4+ 20</td> </tr> </tbody> </table>	I/O 3/4		2 x Digital input		230 V DC/AC	3+ 18	± 20%	4- 19		4+ 20	Digital input module with two digital inputs enables reception of impulse signals.
I/O 1/2																						
2 x Digital input																						
230 V DC/AC	1+ 15																					
± 20%	2- 16																					
	2+ 17																					
I/O 3/4																						
2 x Digital input																						
230 V DC/AC	3+ 18																					
± 20%	4- 19																					
	4+ 20																					

## I/O module 1/2 and 3/4 (terminal numbers 15-20)

<table border="1"> <thead> <tr><th colspan="2">I/O 1/2</th></tr> </thead> <tbody> <tr><td colspan="2">2 x Digital input</td></tr> <tr><td>110 V DC/AC ± 20%</td><td>1 <math>\frac{+}{\sim}</math> 15 2 <math>\frac{-}{\sim}</math> 17</td></tr> </tbody> </table>	I/O 1/2		2 x Digital input		110 V DC/AC ± 20%	1 $\frac{+}{\sim}$ 15 2 $\frac{-}{\sim}$ 17	<table border="1"> <thead> <tr><th colspan="2">I/O 3/4</th></tr> </thead> <tbody> <tr><td colspan="2">2 x Digital input</td></tr> <tr><td>110 V DC/AC ± 20%</td><td>3 <math>\frac{+}{\sim}</math> 18 4 <math>\frac{-}{\sim}</math> 20</td></tr> </tbody> </table>	I/O 3/4		2 x Digital input		110 V DC/AC ± 20%	3 $\frac{+}{\sim}$ 18 4 $\frac{-}{\sim}$ 20	Digital input module with two digital inputs enables reception of impulse signals.								
I/O 1/2																						
2 x Digital input																						
110 V DC/AC ± 20%	1 $\frac{+}{\sim}$ 15 2 $\frac{-}{\sim}$ 17																					
I/O 3/4																						
2 x Digital input																						
110 V DC/AC ± 20%	3 $\frac{+}{\sim}$ 18 4 $\frac{-}{\sim}$ 20																					
<table border="1"> <thead> <tr><th colspan="2">I/O 1/2</th></tr> </thead> <tbody> <tr><td colspan="2">2 x Digital input</td></tr> <tr><td>5...48 V DC/AC</td><td>1 <math>\frac{+}{\sim}</math> 15 2 <math>\frac{-}{\sim}</math> 17</td></tr> </tbody> </table>	I/O 1/2		2 x Digital input		5...48 V DC/AC	1 $\frac{+}{\sim}$ 15 2 $\frac{-}{\sim}$ 17	<table border="1"> <thead> <tr><th colspan="2">I/O 3/4</th></tr> </thead> <tbody> <tr><td colspan="2">2 x Digital input</td></tr> <tr><td>5...48 V DC/AC</td><td>3 <math>\frac{+}{\sim}</math> 18 4 <math>\frac{-}{\sim}</math> 20</td></tr> </tbody> </table>	I/O 3/4		2 x Digital input		5...48 V DC/AC	3 $\frac{+}{\sim}$ 18 4 $\frac{-}{\sim}$ 20	Digital input module with two digital inputs enables reception of impulse signals.								
I/O 1/2																						
2 x Digital input																						
5...48 V DC/AC	1 $\frac{+}{\sim}$ 15 2 $\frac{-}{\sim}$ 17																					
I/O 3/4																						
2 x Digital input																						
5...48 V DC/AC	3 $\frac{+}{\sim}$ 18 4 $\frac{-}{\sim}$ 20																					
<table border="1"> <thead> <tr><th colspan="2">I/O 1/2</th></tr> </thead> <tbody> <tr><td colspan="2">2 x Pulse input</td></tr> <tr><td>5...48 V DC</td><td>1 <math>\frac{+}{-}</math> 15 2 <math>\frac{-}{+}</math> 17</td></tr> </tbody> </table>	I/O 1/2		2 x Pulse input		5...48 V DC	1 $\frac{+}{-}$ 15 2 $\frac{-}{+}$ 17	<table border="1"> <thead> <tr><th colspan="2">I/O 3/4</th></tr> </thead> <tbody> <tr><td colspan="2">2 x Pulse input</td></tr> <tr><td>5...48 V DC</td><td>3 <math>\frac{+}{-}</math> 18 4 <math>\frac{-}{+}</math> 20</td></tr> </tbody> </table>	I/O 3/4		2 x Pulse input		5...48 V DC	3 $\frac{+}{-}$ 18 4 $\frac{-}{+}$ 20	Pulse input module enables reception of pulses from various counters (water, gas, heat, flow ...).								
I/O 1/2																						
2 x Pulse input																						
5...48 V DC	1 $\frac{+}{-}$ 15 2 $\frac{-}{+}$ 17																					
I/O 3/4																						
2 x Pulse input																						
5...48 V DC	3 $\frac{+}{-}$ 18 4 $\frac{-}{+}$ 20																					
<table border="1"> <thead> <tr><th colspan="2">I/O 1/2</th></tr> </thead> <tbody> <tr><td colspan="2">Watchdog / Relay output</td></tr> <tr><td>35 V DC</td><td>1 <math>\frac{+}{\sim}</math> 15</td></tr> <tr><td>40 V AC</td><td>2 <math>\frac{-}{\sim}</math> 16</td></tr> <tr><td>1000 mA</td><td>2 <math>\frac{+}{\sim}</math> 17</td></tr> </tbody> </table>	I/O 1/2		Watchdog / Relay output		35 V DC	1 $\frac{+}{\sim}$ 15	40 V AC	2 $\frac{-}{\sim}$ 16	1000 mA	2 $\frac{+}{\sim}$ 17	<table border="1"> <thead> <tr><th colspan="2">I/O 3/4</th></tr> </thead> <tbody> <tr><td colspan="2">Watchdog / Relay output</td></tr> <tr><td>35 V DC</td><td>3 <math>\frac{+}{\sim}</math> 18</td></tr> <tr><td>40 V AC</td><td>4 <math>\frac{-}{\sim}</math> 19</td></tr> <tr><td>1000 mA</td><td>4 <math>\frac{+}{\sim}</math> 20</td></tr> </tbody> </table>	I/O 3/4		Watchdog / Relay output		35 V DC	3 $\frac{+}{\sim}$ 18	40 V AC	4 $\frac{-}{\sim}$ 19	1000 mA	4 $\frac{+}{\sim}$ 20	Watchdog output and alarm (relay) module enables proper device operation supervision
I/O 1/2																						
Watchdog / Relay output																						
35 V DC	1 $\frac{+}{\sim}$ 15																					
40 V AC	2 $\frac{-}{\sim}$ 16																					
1000 mA	2 $\frac{+}{\sim}$ 17																					
I/O 3/4																						
Watchdog / Relay output																						
35 V DC	3 $\frac{+}{\sim}$ 18																					
40 V AC	4 $\frac{-}{\sim}$ 19																					
1000 mA	4 $\frac{+}{\sim}$ 20																					
<table border="1"> <thead> <tr><th colspan="2">I/O 1/2</th></tr> </thead> <tbody> <tr><td colspan="2">2 x Tariff input</td></tr> <tr><td>230 V AC ± 20%</td><td>1 <math>\frac{\sim}{\sim}</math> 15 2 <math>\frac{\sim}{\sim}</math> 17</td></tr> </tbody> </table>	I/O 1/2		2 x Tariff input		230 V AC ± 20%	1 $\frac{\sim}{\sim}$ 15 2 $\frac{\sim}{\sim}$ 17	Tariff input module with two tariff inputs for changeover between up to four tariffs.															
I/O 1/2																						
2 x Tariff input																						
230 V AC ± 20%	1 $\frac{\sim}{\sim}$ 15 2 $\frac{\sim}{\sim}$ 17																					
<table border="1"> <thead> <tr><th colspan="2">I/O 1/2</th></tr> </thead> <tbody> <tr><td colspan="2">2 x Tariff input</td></tr> <tr><td>110 V AC ± 20%</td><td>1 <math>\frac{\sim}{\sim}</math> 15 2 <math>\frac{\sim}{\sim}</math> 17</td></tr> </tbody> </table>	I/O 1/2		2 x Tariff input		110 V AC ± 20%	1 $\frac{\sim}{\sim}$ 15 2 $\frac{\sim}{\sim}$ 17	Tariff input module with two tariff inputs for changeover between up to four tariffs.															
I/O 1/2																						
2 x Tariff input																						
110 V AC ± 20%	1 $\frac{\sim}{\sim}$ 15 2 $\frac{\sim}{\sim}$ 17																					
<table border="1"> <thead> <tr><th colspan="2">I/O 1/2</th></tr> </thead> <tbody> <tr><td colspan="2">2 x Tariff input</td></tr> <tr><td>5...48 V AC</td><td>1 <math>\frac{\sim}{\sim}</math> 15 2 <math>\frac{\sim}{\sim}</math> 17</td></tr> </tbody> </table>	I/O 1/2		2 x Tariff input		5...48 V AC	1 $\frac{\sim}{\sim}$ 15 2 $\frac{\sim}{\sim}$ 17	Tariff input module with two tariff inputs for changeover between up to four tariffs.															
I/O 1/2																						
2 x Tariff input																						
5...48 V AC	1 $\frac{\sim}{\sim}$ 15 2 $\frac{\sim}{\sim}$ 17																					

**⚠ WARNING**

In case when only one resistance-temperature analogue input is used, the other must be short-circuited.



## Auxiliary I/O module A and B – output options

<table border="1"> <tr> <td colspan="2"><b>I/O A</b></td> <td colspan="8"><b>8 x Relay output</b></td> </tr> <tr> <td colspan="10">230 V DC/AC 100 mA</td> </tr> <tr> <td>C</td> <td>1-</td> <td>2-</td> <td>3-</td> <td>4-</td> <td>5-</td> <td>6-</td> <td>7-</td> <td>8-</td> <td></td> </tr> <tr> <td></td> <td>+</td> <td>+</td> <td>+</td> <td>+</td> <td>+</td> <td>+</td> <td>+</td> <td>+</td> <td></td> </tr> <tr> <td></td> <td>30</td> <td>31</td> <td>32</td> <td>33</td> <td>34</td> <td>35</td> <td>36</td> <td>37</td> <td>38</td> </tr> </table>	<b>I/O A</b>		<b>8 x Relay output</b>								230 V DC/AC 100 mA										C	1-	2-	3-	4-	5-	6-	7-	8-			+	+	+	+	+	+	+	+			30	31	32	33	34	35	36	37	38	Relay output module with eight outputs enables alarm functionality.
<b>I/O A</b>		<b>8 x Relay output</b>																																																	
230 V DC/AC 100 mA																																																			
C	1-	2-	3-	4-	5-	6-	7-	8-																																											
	+	+	+	+	+	+	+	+																																											
	30	31	32	33	34	35	36	37	38																																										
<table border="1"> <tr> <td colspan="2"><b>I/O B</b></td> <td colspan="8"><b>8 x Digital input</b></td> </tr> <tr> <td colspan="10">230 V DC/AC <math>\pm 20\%</math></td> </tr> <tr> <td>C</td> <td>1</td> <td>2</td> <td>3</td> <td>4</td> <td>5</td> <td>6</td> <td>7</td> <td>8</td> <td></td> </tr> <tr> <td></td> <td>+</td> <td>+</td> <td>+</td> <td>+</td> <td>+</td> <td>+</td> <td>+</td> <td>+</td> <td></td> </tr> <tr> <td></td> <td>40</td> <td>41</td> <td>42</td> <td>43</td> <td>44</td> <td>45</td> <td>46</td> <td>47</td> <td>48</td> </tr> </table>	<b>I/O B</b>		<b>8 x Digital input</b>								230 V DC/AC $\pm 20\%$										C	1	2	3	4	5	6	7	8			+	+	+	+	+	+	+	+			40	41	42	43	44	45	46	47	48	Digital input module with eight digital inputs enables reception of digital signals.
<b>I/O B</b>		<b>8 x Digital input</b>																																																	
230 V DC/AC $\pm 20\%$																																																			
C	1	2	3	4	5	6	7	8																																											
	+	+	+	+	+	+	+	+																																											
	40	41	42	43	44	45	46	47	48																																										

### PLEASE NOTE

Relay output only possible on I/O module A.

## Synchronization module C

<table border="1"> <tr> <td colspan="2"><b>I/O C</b></td> </tr> <tr> <td><b>IRIG-B</b></td> <td></td> </tr> <tr> <td><b>1PPS</b></td> <td><b>53</b></td> </tr> <tr> <td rowspan="2"><b>RS485</b></td> <td>A <b>54</b></td> </tr> <tr> <td>B <b>55</b></td> </tr> <tr> <td rowspan="3"><b>MODEM</b></td> <td>Rx <b>56</b></td> </tr> <tr> <td>↓ <b>57</b></td> </tr> <tr> <td>Tx <b>58</b></td> </tr> <tr> <td></td> <td>+5V <b>59</b></td> </tr> </table>	<b>I/O C</b>		<b>IRIG-B</b>		<b>1PPS</b>	<b>53</b>	<b>RS485</b>	A <b>54</b>	B <b>55</b>	<b>MODEM</b>	Rx <b>56</b>	↓ <b>57</b>	Tx <b>58</b>		+5V <b>59</b>	<p>The Synchronization module is equipped to support two different synchronization methods: IRIG-B and GPS modem.</p> <p>The BNC connector only supports modulated IRIG-B.</p> <p>The 1PPS terminal supports unmodulated (level-shift) IRIG-B and is also used when in the case of a GPS modem.</p> <p>In case of GPS modem, 1PPS signal should be connected to 1PPS terminal and serial RS232 signal should be connected to RS232 terminals.</p> <p>When IRIG-B (modulated or unmodulated (level-shift)) or the 1PPS signal is used for time synchronization the serial communication interface (RS232 or RS485) can be used as a devices' secondary communication port (COM2).</p>
<b>I/O C</b>																
<b>IRIG-B</b>																
<b>1PPS</b>	<b>53</b>															
<b>RS485</b>	A <b>54</b>															
	B <b>55</b>															
<b>MODEM</b>	Rx <b>56</b>															
	↓ <b>57</b>															
	Tx <b>58</b>															
	+5V <b>59</b>															

### PLEASE NOTE

Communication port on Module C is primarily dedicated to receive serial coded date and time telegram from a GPS receiver in order to synchronize internal real time clock (RTC). When other methods are used for synchronizing RTC this communication port can be used as a secondary general purpose communication port.

Please note that either RS232 or RS485 should be used and not both at a time. Connector terminals that are not used should remain unconnected otherwise the communication could not work properly.

### CAUTION

RTC synchronization is essential part of Class A instrument. If no proper RTC synchronization is provided device operates as Class S instrument.

### CAUTION

Max consumption of +5V supply terminal is 100mA. When GPS with consumption greater the 100mA is used it is advisable to use external power supply.

## Communication connection

Primary communication interface (COM1) type is normally specified when placing an order. ISTAT M365A/M365B supports Ethernet communication designed as standard RJ-45 terminal and USB communication designed as standard USB-B type terminal



Beside primary communication port, ISTAT M365A/M365B has built in a secondary communication port (COM2) as a part of a real time synchronization module C. Its operation is described in a chapter referring to a real time synchronization Serial communication via Synchronization module C (COM2).

Connect a communication line by means of a corresponding terminal. Communication parameters are stated on the device label, regarding the selected/equipped type of communication. Connector terminals are marked on the label on a devices' rear side. More detailed information on communication is given in chapter Settings – Communications.

<b>COMMUNICATION</b>
Ethernet
MAC No.: 00-1B-DF-54-7B-4A
USB 2.0 Type B

Example of a label for Ethernet/USB communication module equipped with RJ-45 and USB-B type connector

### Survey of communication connection

	Connector	Terminals	Description
<b>Ethernet</b>	RJ-45		100BASE-T CAT5 cable recommended
<b>USB</b>	USB-B		Standard USB 2.0 compatible cable recommended (Type B plug)

## Connection of Real Time Synchronization module C

Synchronized real-time clock (RTC) is an essential part of any Class A analyzer for proper chronological determination of various events. To distinct cause from consequence, to follow a certain event from its origin to manifestation in other parameters it is very important that each and every event and recorded measurement on one instrument can be compared with events and measurements on other devices. Even if instruments are dislocated, which is normally the case in electro distribution network events have to be time-comparable with accuracy better than a single period.

Synchronization module is used to synchronize RTC of the device and to maintain its accuracy for correct aggregation intervals and time stamps of recorded events appearing in monitored electro distribution network.

Different types of RTC synchronization are possible:

- IRIG-B modulated (BNC); 1 kHz modulation with <1ms resolution.
- IRIG-B unmodulated (level shift) (1PPS)
- 1PPS + RS232 Date & Time telegram (from GPS)

### PLEASE NOTE

For safety purposes it is important that all three wires (Line, Neutral and Protective Earth) are firmly connected. They should be connected only to the designated terminals as shown on the label above as well as on the front foil.

The iSTAT M365 supports multiple types of time synchronization to ensure accuracy and synchronization of various measurements and events to meet standards.

GE Reason RT43x GNSS clocks are recommended to provide accurate time synchronization. More details on GE Reason products can be found at [www.gegridsolutions.com](http://www.gegridsolutions.com)

### GPS Time Synchronization (PPS and NMEA)

1pps and serial RS232 communication with NMEA 0183 sentence support

The interface is designed as 5 pole pluggable terminal (+5V for receiver supply, 1pps input and standard RS232 communication interface).

### IRIG time code B (IRIG-B)

Unmodulated (DC 5V level shift) and modulated (1 kHz) serial coded format with support for 1pps, day of year, current year and straight seconds of day as described in standard IRIG-200-04.

Supported serial time code formats are IRIG-B007 and IRIG-B127 Interface for modulated IRIG-B is designed as BNC-F terminal with 600 Ohm input impedance.

Interface for unmodulated IRIG-B is designed as pluggable terminal.

### Network time protocol (NTP):

Synchronization via Ethernet requires access to a NTP server.

#### PLEASE NOTE

NTP can usually maintain time to within tens of milliseconds over the public Internet, but the accuracy depends on infrastructure properties - asymmetry in outgoing and incoming communication delay affects systematic bias. It is recommended that dedicated network rather than public network is used for synchronization purposes.

#### CAUTION

RTC synchronization is essential part of Class A instrument. If no proper RTC synchronization is provided device operates as Class S instrument.

### Survey of synchronization connection

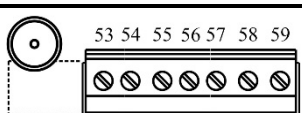
Terminals	Connector type
	BNC for modulated IRIG-B and Pluggable screw terminals for level-shift IRIG-B, GPS modem or serial RS232 or RS485

Connector	Position	Data direction	Description
BNC connector	600 Ohm input impedance: standard Coaxial cable (55 Ohm) recommended		
Screw terminal	53	1PPS (GPS) or IRIG-B (level shift)	Synchronization pulse
	54	To/From (A)	RS485
	55	To/From (B)	RS485
	56	To	Data reception (Rx)
	57	GND	Grounding
	58	From	Data transmission (Tx)

	59	+5V	AUX voltage +5V (supply for GPS modem)
--	----	-----	---

When IRIG-B or 1PPS signal is used for time synchronization serial communication interface (RS232 or RS485) can be used as a devices' secondary communication port (COM2).

More information regarding use of Synchronization module C please see chapter Inputs and Outputs - RTC Synchronization module C.

## Connection of Aux. Power supply

ISTAT M365A/M365B is equipped with auxiliary power supply.

**Voltage range:** 80...300 V DC  
80...276 V AC;  
40...65 Hz

Information on electric consumption is given in chapter Technical Data - Auxiliary Power Supply. Choose and connect the power supply voltage according to power supply voltage specification on the label:

SUPPLY		
80...300 V DC	⏚	12
80...276 V AC	+~L	13
40...65 Hz	-~N	14
< 8 VA		
300V CAT III		

Connection of auxiliary power supply to terminals 13 and 14.

### CAUTION

Aux. supply inrush current can be as high as 20A for short period of time (<1 ms). Please choose an appropriate MCB for connection of aux. supply.

# FIRST STEPS

Programming the iSTAT M365B/M365A is designed to be user-friendly through the keypad display on the meter front panel or through the provided QDSP2.1 setup software for iSTAT meters. This chapter provides basic programming steps for the keypad display on meter front panel.

Only certain settings can be programmed through the keypad display on the meter front panel while all settings can be programmed using the QDSP2.1 setup software.

## Keyboard navigation

### M365A

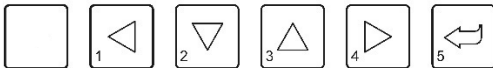

The Enter key (5) is used for confirming/selecting the settings. Direction keys (1 ... 4) are used for navigating between screens and menus. Function of individual key may vary depending on the selected screen.

### M365B

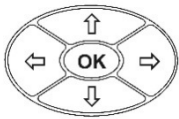

The "OK" key is used for confirming the settings, selecting and exiting the display. Direction keys are used for shifting between screens and menus.

#### Hold function:

Screen displaying measurements can be frozen using hold function. When measurements screen is selected, pressing OK button activates Hold function. Screen is frozen for 1 min. To exit hold function Press OK button again. Screen will return to previous menu.

Vertical line on the right side of the screen indicates frozen screen – hold function:

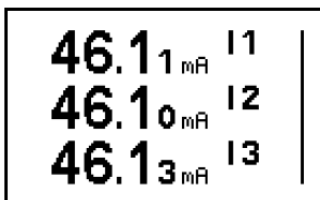

# Installation wizard

## M365A

After installation and electrical connection, basic parameters have to be set in order to assure correct operation. The easiest way to achieve that is use the Installation wizard. When entering the Installation menu, settings follow one another when the previous one is confirmed. All required parameters shall be entered and confirmed. Exit from the menu is possible when all required settings are confirmed or with back key without changes.

Installation wizard menu may vary, depending on built in communication modules. In description below is marked which menu appears for specific option.

---

### PLEASE NOTE

All settings that are performed through the Installation wizard can be subsequently changed by means of the Settings menu or via QDSP2.1 software.

---

When entering installation wizard following display is shown:

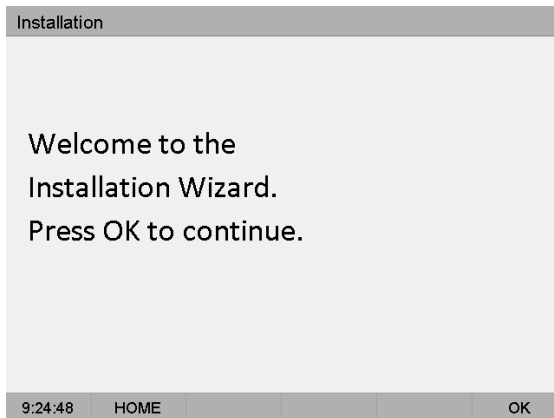

## Language

Set device language.

## Date

Set device date.

## Time

Set device time. If instrument is connected to one of supported time synchronization sources, date and time are automatically set.

## Connection mode

Choose connection from a list of supported connection modes.

## Primary voltage

Set primary voltage of monitored system if a device is connected indirectly by means of a voltage transformer. If device is connected to directly to a low voltage enter this value.

## Secondary voltage

Set secondary voltage if a voltage transformer is used; set voltage of low voltage network if connection is direct.

**Primary current**

Set primary current of monitored system if a device is connected indirectly by means of a current transformer. Otherwise primary and secondary current should remain the same.

**Secondary current**

Set secondary current of current transformer or the value of nominal current if connection is direct.

**Common energy counter resolution**

Define Common energy counter resolution as recommended in table below, where Individual counter resolution is at default value 10. Values of primary voltage and current determine proper Common energy counter resolution. For detailed information about setting energy parameters see chapter

Suggested Common energy counter resolutions:

Current Voltage	1 A	5 A	50 A	100 A	1000 A
110 V	100 mWh	1 Wh	10 Wh	10 Wh	100 Wh
230 V	1 Wh	1 Wh	10 Wh	100 Wh	1 kWh
1000 V	1 Wh	10 Wh	100 Wh	1 kWh	10 kWh
30 kV	100 Wh	100 Wh	1 kWh	10 kWh	10 kWh *

\* – Individual counter resolution should be at least 100

**Device address**

Set MODBUS address for the device. Default address is 33.

**IP Address**

Set correct IP address of the device. Default setting is 0.0.0.0 and represents DHCP addressing. This setting is available only when Ethernet communication is built in.

**TCP Port**

Set TCP communication Port. Default value is 10001. This setting is available only when Ethernet communication is built in.

**Subnet mask**

Set network subnet mask. Default value is 255.255.255.0. This setting is available only when Ethernet communication is built in.

## M365B

After installation and electrical connection, basic parameters have to be set in order to assure correct operation. The easiest way to achieve that is use the Installation wizard. When entering the Installation menu, settings follow one another when the previous one is confirmed. All required parameters shall be entered and confirmed. Exit from the menu is possible when all required settings are confirmed or with interruption (key  $\leftarrow$  several times) without changes.

Installation wizard menu may vary, depending on built in communication modules. In description below is marked which menu appears for specific option.

### PLEASE NOTE

All settings that are performed through the Installation wizard can be subsequently changed by means of the Settings menu or via QDSP2.1 software.

When entering installation wizard following display is shown:

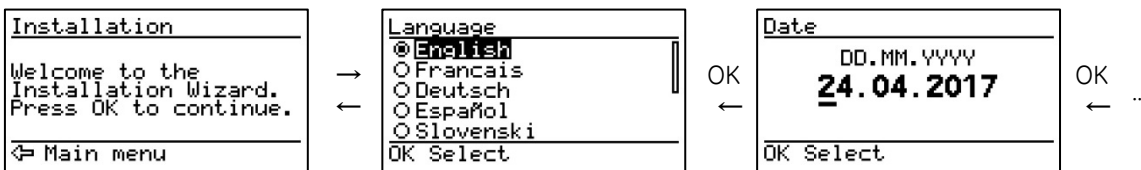

### Language

Set device language.

### Date

Set device date.

### Time

Set device time. If instrument is connected to one of supported time synchronization sources, date and time are automatically set.

### Connection mode

Choose connection from a list of supported connection modes.

### Primary voltage

Set primary voltage of monitored system if a device is connected indirectly by means of a voltage transformer. If device is connected to directly to a low voltage enter this value.

### Secondary voltage

Set secondary voltage if a voltage transformer is used; set voltage of low voltage network if connection is direct.

### Primary current

Set primary current of monitored system if a device is connected indirectly by means of a current transformer. Otherwise primary and secondary current should remain the same.

### Secondary current

Set secondary current of current transformer or the value of nominal current if connection is direct.

### Common energy counter resolution

Define Common energy counter resolution as recommended in table below, where Individual counter resolution is at default value 10. Values of primary voltage and current determine proper Common energy counter resolution. For detailed information about setting energy parameters see chapter

Suggested Common energy counter resolutions:

Current Voltage	1 A	5 A	50 A	100 A	1000 A
110 V	100 mWh	1 Wh	10 Wh	10 Wh	100 Wh
230 V	1 Wh	1 Wh	10 Wh	100 Wh	1 kWh
1000 V	1 Wh	10 Wh	100 Wh	1 kWh	10 kWh
30 kV	100 Wh	100 Wh	1 kWh	10 kWh	10 kWh *

\* – Individual counter resolution should be at least 100

### Device address

Set MODBUS address for the device. Default address is 33.

### IP Address

Set correct IP address of the device. Default setting is 0.0.0.0 and represents DHCP addressing. This setting is available only when Ethernet communication is built in.

### TCP Port





Set TCP communication Port. Default value is 10001. This setting is available only when Ethernet communication is built in.

### Subnet mask

Set network subnet mask. Default value is 255.255.255.0. This setting is available only when Ethernet communication is built in.

## Notification icons (M365B only)

Navigation keys and LCD enable application and basic instrument settings. During the operation some icons can be displayed in upper part of LCD. The significance of icons (from right to left) is explained in the table below.

Icon	Meaning
	ISTAT M365A/M365B is locked with a password of the second level (L2). The first level (L1) can be unlocked.
	ISTAT M365A/M365B can be wrongly connected at 4u connection. Energy flow direction is different by phases.
	A built-in battery (for RTC) shall be replaced. A battery test is carried out at power supply connection (for devices with built in battery).
	The power supply to the iSTAT M365B is too low.
	Clock not set (for devices with built in super cap). (when disconnected from aux. supply for more than 2 days)

### PLEASE NOTE

Notification icons only apply to Power Quality Analyzer M365B.

# Screen Navigation

## M365B

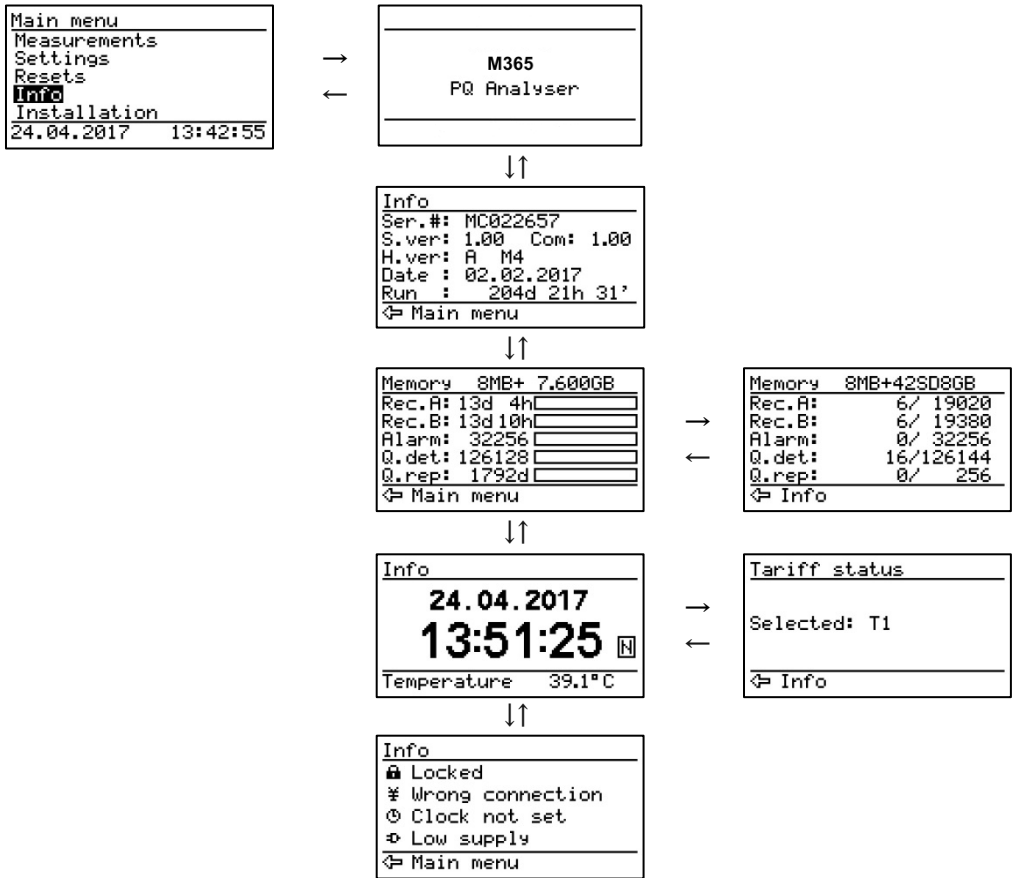

## M365A

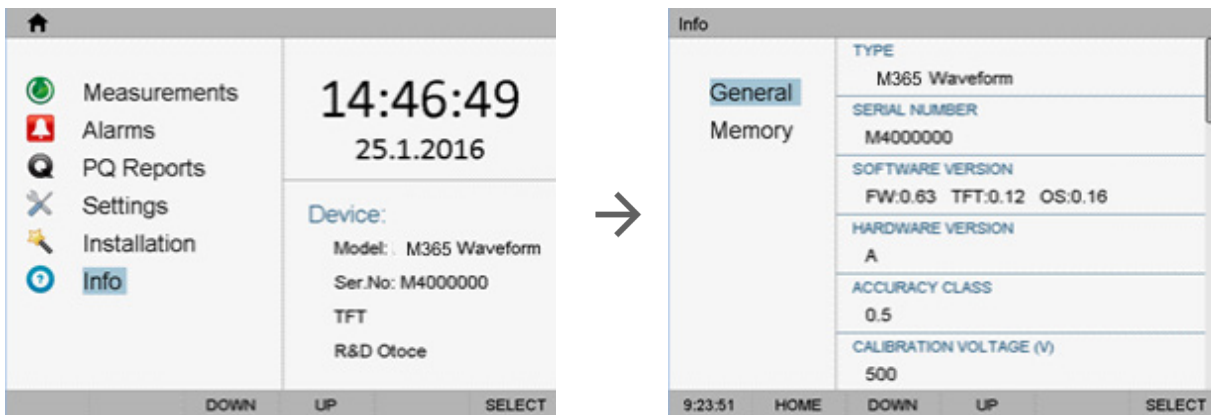

Main menu > Settings > General:

- TYPE
- SERIAL NUMBER
- SOFTWARE VERSION
- HARDWARE VERSION
- ACCURACY CLASS
- CALIBRATION VOLTAGE (V)

## SETTINGS

Settings of ISTAT M365A/M365B can be performed via the front keypad and display or remotely using communication and QDSP2.1 software version 2.1 or higher.

Via navigation keypad basic and simpler settings are available. Complete setting of the device can be done using QDSP2.1 software. In this case they can be applied to the device via.

## QDSP2.1 software

QDSP2.1 software is a tool for a complete programming and monitoring of GE Vernova measuring instruments. Remote operation is possible by means of serial (RS485/RS232), USB or TCP/IP communication. A user-friendly interface consists of six segments: Connection, Settings, Measurements, Analysis, My Devices and Upgrades. These segments are easily accessed by means of six icons on the left side:

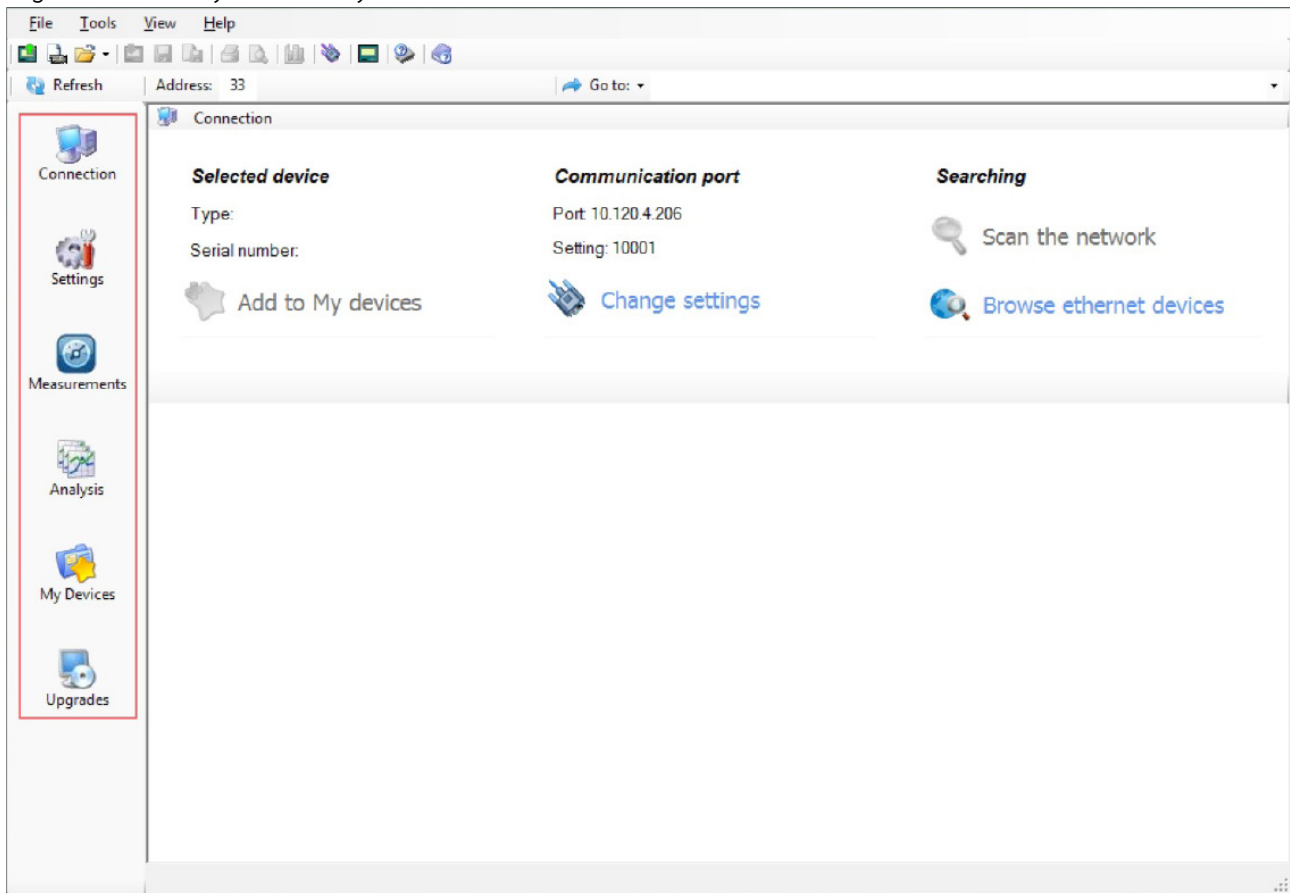

Latest version of QDSP2.1 software can be obtained from our Contact Centre via:  
[www.gegridsolutions.com/contact](http://www.gegridsolutions.com/contact).

### **PLEASE NOTE**

QDSP2.1 has very intuitive help system. All functions and settings are described in Info window on the bottom of QDSP2.1 window. In QDSP2.1 Help file, detailed instructions about software usage, connection and communication with different type of devices, driver installation,... are described.

## Device Management

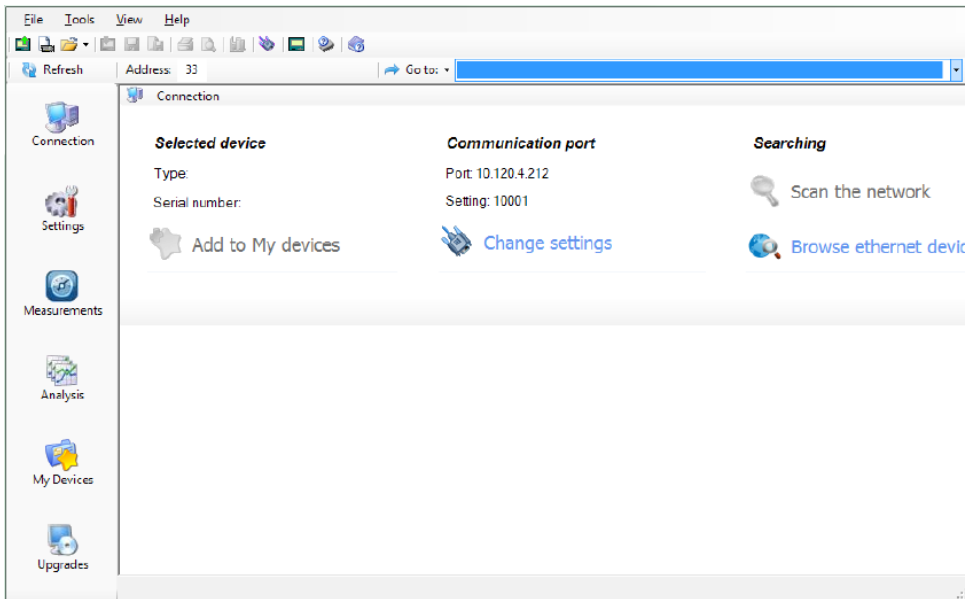

### QDSP2.1 Device Management window

With QDSP2.1 it is very easy to manage devices. If dealing with the same device that has been accessed before, it can be easily selected from a favorites' line.

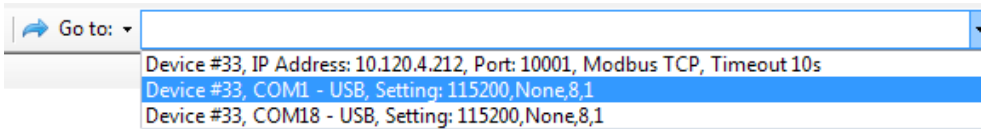

This way is Communication port set automatically as it was during last access.

To communicate with new device follow below instructions:

Connect a device to a communication interface (Depending on type of device):

- Directly to a PC using RS232 cable
- To comm. adapter RS485 / RS232
- Directly to a PC using USB cable
- Network connection using Ethernet cable

### Set Communication Port Parameters

Under Communication port current communication parameters are displayed. To change those parameters click on  **Change settings** button. A Communication port window opens with settings for different communication interfaces.

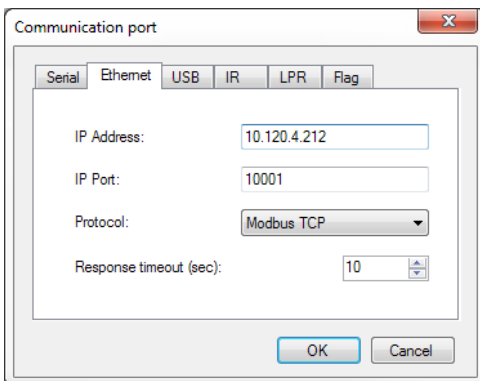

To activate desired communication select proper communication tab, set communication parameters and confirm selection with OK button.

**PLEASE NOTE**

When an iSTAT device with USB communications is connected to a computer for the first time, the device driver will be installed automatically. If installation is successful, the device appears in the operating system (Device manager - Ports (COM and LPT)) as a Measuring Device. If device is not recognized automatically or the wrong driver is installed, valid installation drivers are available in the QDSP2.1 installation directory (subdirectory Drivers).

With this driver installed, the USB is redirected to a serial port, which should be selected when using QDSP2.1 software.

For more information regarding communication parameters, please see chapter Communications.

**Set device Modbus address number**

Each device connected to a network has its unique Modbus address number. In order to communicate with that device an appropriate address number should be set.

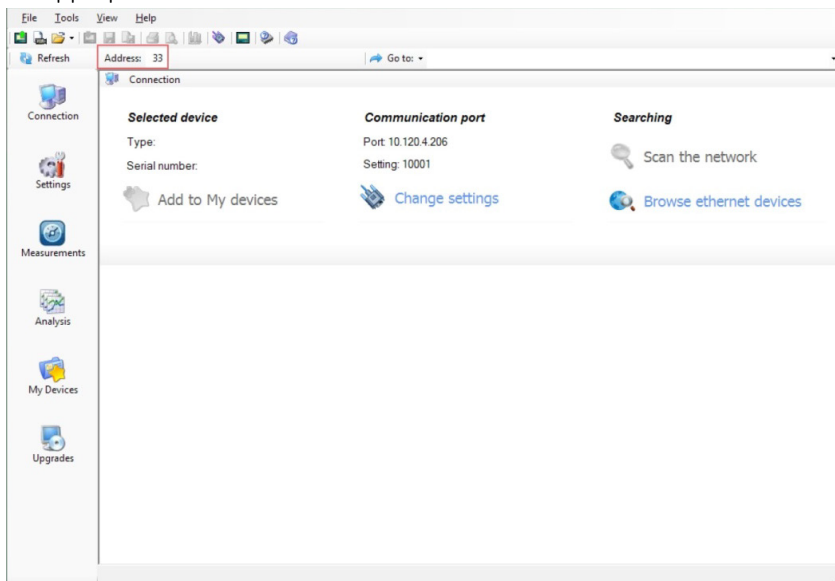

Factory default Modbus address for all devices is 33. If devices are connected to a communication network, all should have the same communication parameters, but each of them should have its own unique address.

**Start communicating with a device**

Click on Refresh button and device information will be displayed:

**Selected device**

Type: M365, Soft. Ver.: 0.48

Serial number: M8000000

When devices are connected to a network and a certain device is required it is possible to browse a network for devices. For this purpose choose:

- **Scan the network** when device is connected to a RS485/RS232 bus
- **Browse Ethernet devices** when device is connected to the Ethernet

**Searching**

Scan the network

Browse ethernet devices

## Settings

Programming ISTAT M365A/M365B can be performed ONLINE when device is connected to aux. power supply and is communicating with QDSP2.1. When device is not connected it is possible to adjust settings OFFLINE.

### Online programming

After communication with ISTAT M365A/M365B is established, choose icon Settings from the list of QDSP2.1 functions on a left side.

QDSP2.1 Device Setting window:

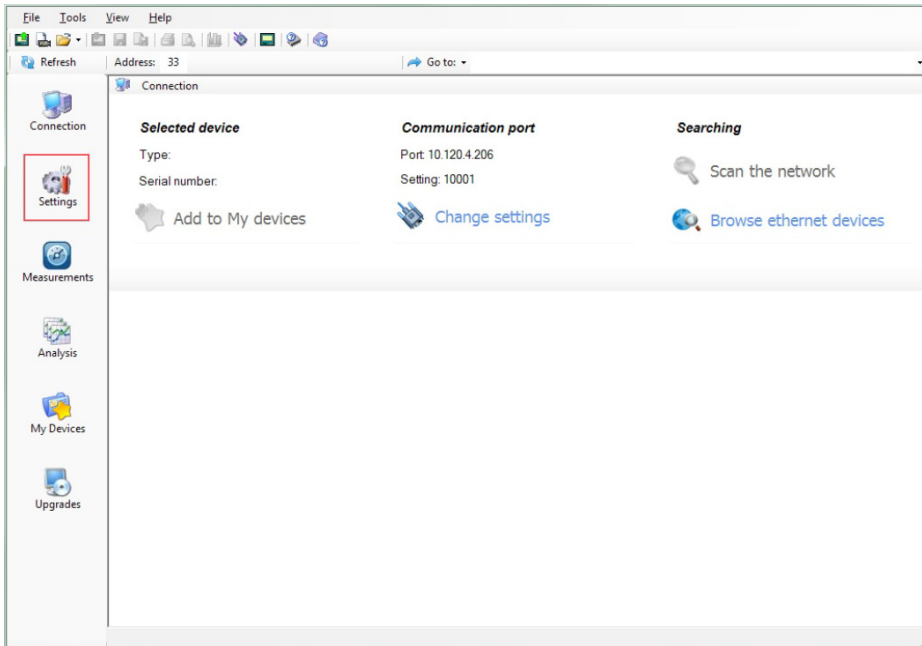

Choose Read settings  button to display all devices settings and begin adjusting them according to project requirement.

---

#### PLEASE NOTE

When finished programming, changes should be confirmed by pressing Download settings  button in QDSP2.1 menu bar or with a mouse right click menu.

---



---

#### PLEASE NOTE

When finished programming, all settings can be saved in a setting file (\*.msf file). This way it is possible to archive settings in combination with a date. It is also possible to use saved settings for offline programming or to program other devices with same settings. For more information see OFFLINE programming on next page.

---

## Offline programming

When ISTAT M365A/M365B is not physically present or is unable to communicate, it is still possible to perform OFFLINE programming. From QDSP2.1 Device Setting window choose Open setting file button.

From a list of \*.msf files choose either previously stored file (a setting file, which has been used for another device and stored) or a file MXxxx.msf, which holds default settings for this device.

When confirmed all device settings are displayed similar as with ONLINE programming.

When finished programming, all settings can be saved in a setting file with a meaningful name (e.g. MXxxx\_location\_date.msf). If file will be used for setting the device via Memory card (only for devices with Memory card support), special name format needs to be used.

Settings are stored in the directory setting using two recording modes:

- With a type designation and a sequence number from 1 to 9
- With an device serial number

### CAUTION

MXxxx.msf file or any other original device setting file should not be modified as it contains device default settings. Please save setting file under another name before adjusting it with your own project requirements.

## Measurements

Measurements can be seen ONLINE when ISTAT M365A/M365B is connected to aux. power supply and is communicating with QDSP2.1. When device is not connected it is possible to see OFFLINE measurements simulation. The latter is useful for presentations and visualization of measurements without presence of actual device.

In ONLINE mode all supported measurements and alarms can be seen in real time in a Table view. For some devices also presentation in graphical form is supported.

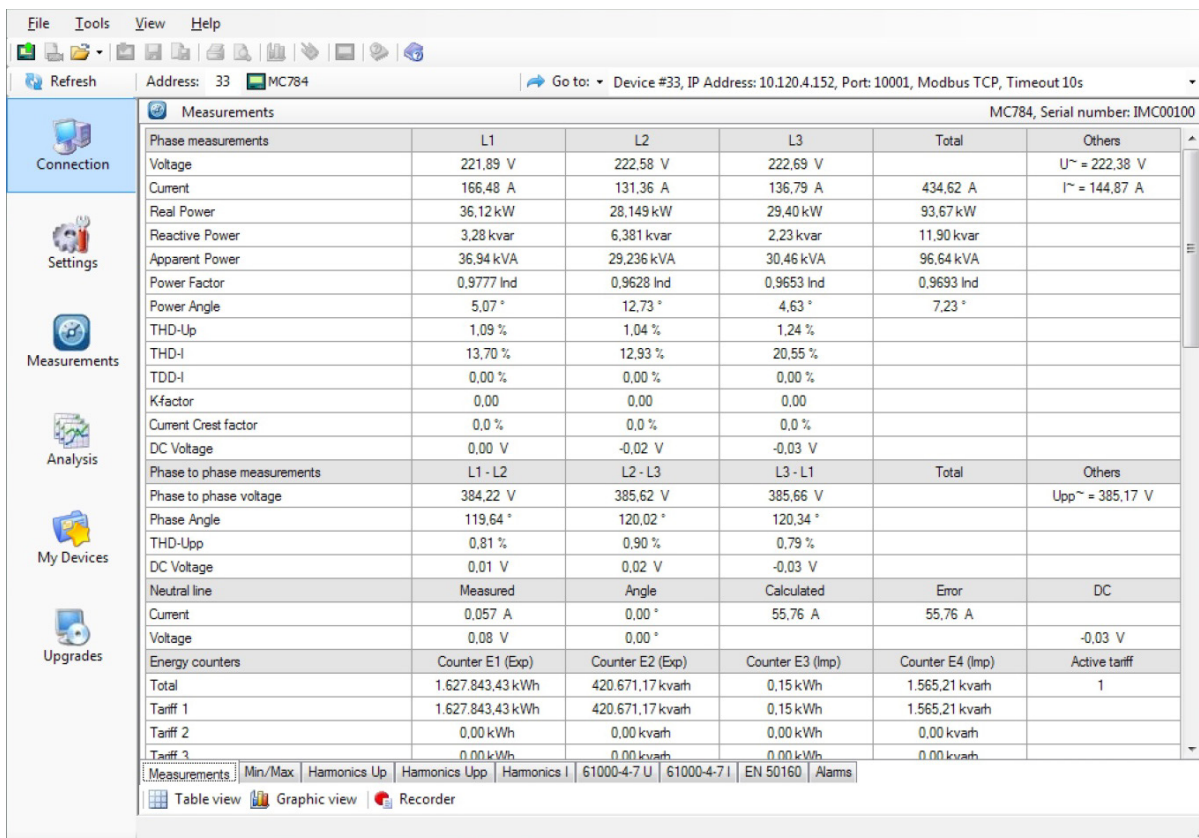

The screenshot shows the 'Measurements' window in the software. The interface includes a menu bar (File, Tools, View, Help), a toolbar, and a navigation sidebar with icons for Connection, Settings, Measurements, Analysis, My Devices, and Upgrades. The main area displays a table of measurements for device MC784 (Serial number: IMC00100). The table is organized into sections: Phase measurements, Phase to phase measurements, Neutral line, and Energy counters. At the bottom, there are tabs for 'Table view', 'Graphic view', and 'Recorder', and a status bar with various indicators like 'Min/Max', 'Harmonics Up', and 'Alarms'.

Measurements						MC784, Serial number: IMC00100	
Phase measurements		L1	L2	L3	Total	Others	
Voltage		221.89 V	222.58 V	222.69 V		U <sub>~</sub> = 222.38 V	
Current		166.48 A	131.36 A	136.79 A	434.62 A	I <sub>~</sub> = 144.87 A	
Real Power		36.12 kW	28.149 kW	29.40 kW	93.67 kW		
Reactive Power		3.28 kvar	6.381 kvar	2.23 kvar	11.90 kvar		
Apparent Power		36.94 kVA	29.236 kVA	30.46 kVA	96.64 kVA		
Power Factor		0.9777 Ind	0.9628 Ind	0.9653 Ind	0.9693 Ind		
Power Angle		5.07 °	12.73 °	4.63 °	7.23 °		
THD-Up		1.09 %	1.04 %	1.24 %			
THD-I		13.70 %	12.93 %	20.55 %			
TDD-I		0.00 %	0.00 %	0.00 %			
Kfactor		0.00	0.00	0.00			
Current Crest factor		0.0 %	0.0 %	0.0 %			
DC Voltage		0.00 V	-0.02 V	-0.03 V			
Phase to phase measurements		L1 - L2	L2 - L3	L3 - L1	Total	Others	
Phase to phase voltage		384.22 V	385.62 V	385.66 V		U <sub>pp~</sub> = 385.17 V	
Phase Angle		119.64 °	120.02 °	120.34 °			
THD-Upp		0.81 %	0.90 %	0.79 %			
DC Voltage		0.01 V	0.02 V	-0.03 V			
Neutral line		Measured	Angle	Calculated	Error	DC	
Current		0.057 A	0.00 °	55.76 A	55.76 A		
Voltage		0.08 V	0.00 °			-0.03 V	
Energy counters		Counter E1 (Exp)	Counter E2 (Exp)	Counter E3 (Imp)	Counter E4 (Imp)	Active tariff	
Total		1.627.843.43 kWh	420.671.17 kvarh	0.15 kWh	1.565.21 kvarh	1	
Tariff 1		1.627.843.43 kWh	420.671.17 kvarh	0.15 kWh	1.565.21 kvarh		
Tariff 2		0.00 kWh	0.00 kvarh	0.00 kWh	0.00 kvarh		
Tariff 3		0.00 kWh	0.00 kvarh	0.00 kWh	0.00 kvarh		

Online measurements in Table view

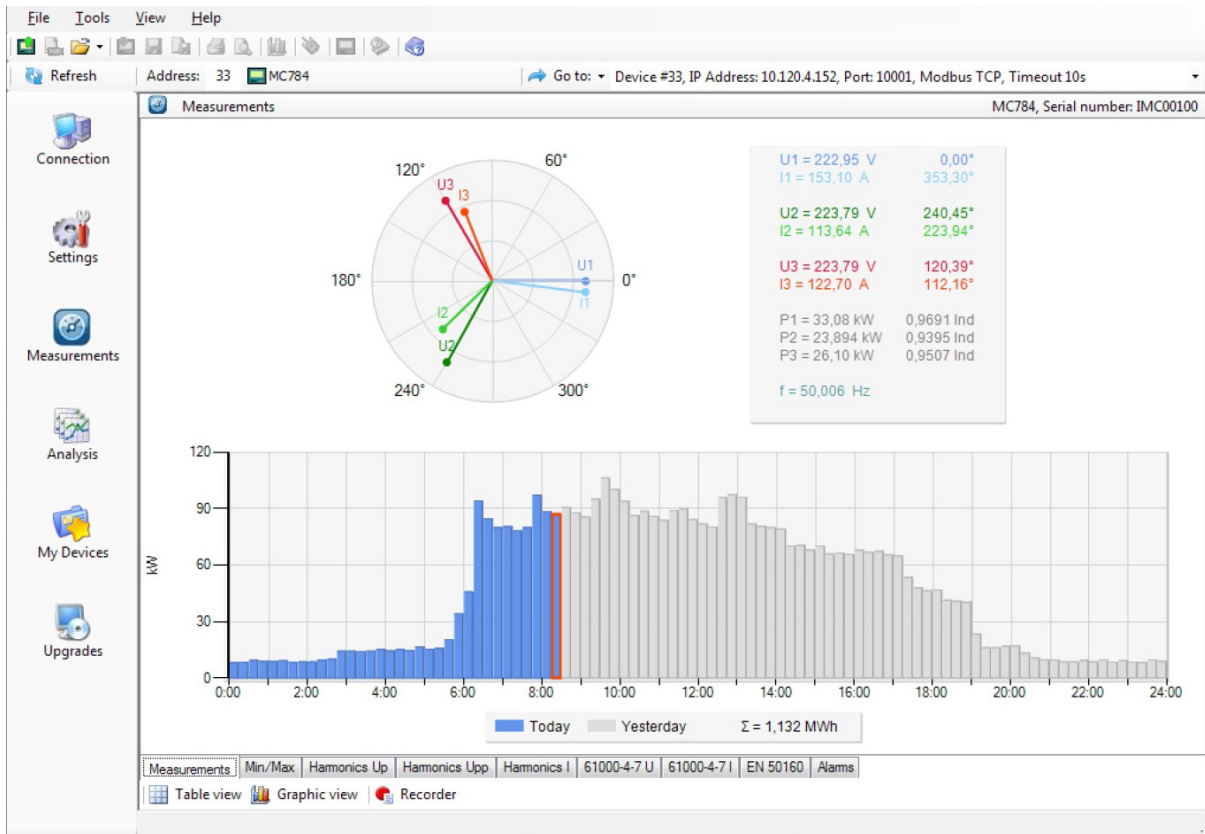

Online measurements in graphical form – phasor diagram and daily total active power consumption histogram

Different measuring data can be accessed by means of tabs (Measurements, Min/Max...) in the lower part of QDSP2.1 window.

For further processing of real time measuring results, it is possible to set a recorder (  Recorder button) on active device that will record and save selected measurements to MS Excel .csv file format. Data can then be analyzed and processed in any program that supports files in CSV format.

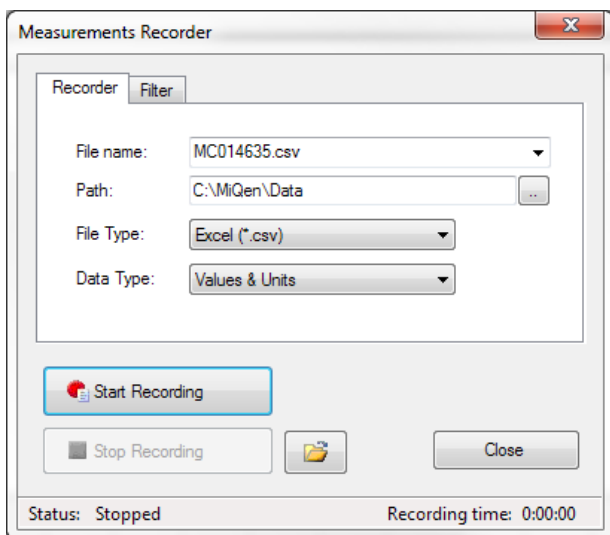

Window for setting local database recording parameters

## Data Analysis

QDSP2.1 enables also analysis of the historical data stored in ISTAT M365A/M365B internal memory (for devices with built in memory only). In order to perform analysis data source has to be defined first. Data source can be one of the selected:

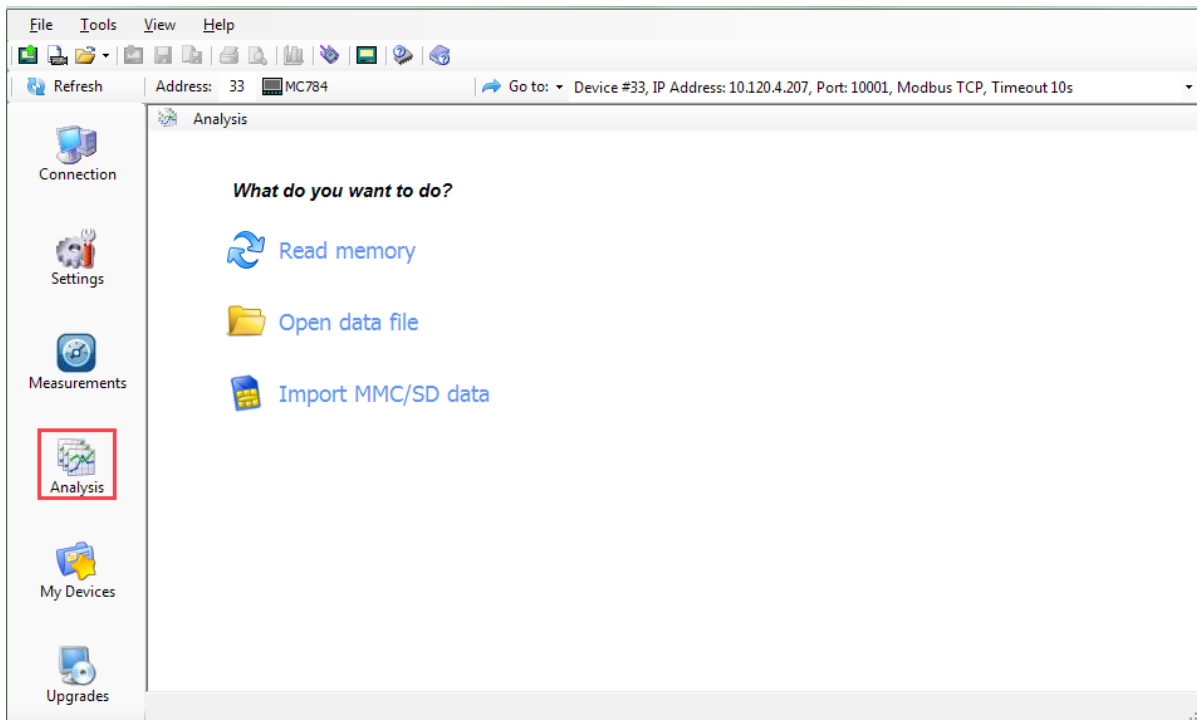

### Read memory

This option should be selected to download and analyze the data from currently active device. Data is read directly from a devices internal memory.

### Open data file

This option should be selected to analyze the data already stored on the computer. Data is read from a local database.

## My Devices

In My Devices user can store connections to devices that are used more often. Each device can be assigned to user defined group and equipped with user defined description and location for easier recognition. By selecting device from the list, access to device settings and downloaded and recorded files is much easier.

## Upgrades

In the Upgrades section, the latest software updates for both for Software (QDSP2.1) and GE Vernova measuring devices can be found. The latest version should always be used to assure full functionality. Manual or automatic checking for upgrades is available via a required Internet connection.

The list of available updates provided in sections for easier navigation and details such as the Upgrade Version, Download Link and History File are provided.

## Software upgrading

After downloading all necessary firmware upgrade files you can perform upgrades using QDSP2.1 software. The device to be upgraded first needs to be added to My Devices. To do this the device you want to upgrade should first be selected from the list of available devices or by directly entering its' communication settings:

1. Connect to your device via Ethernet communication:

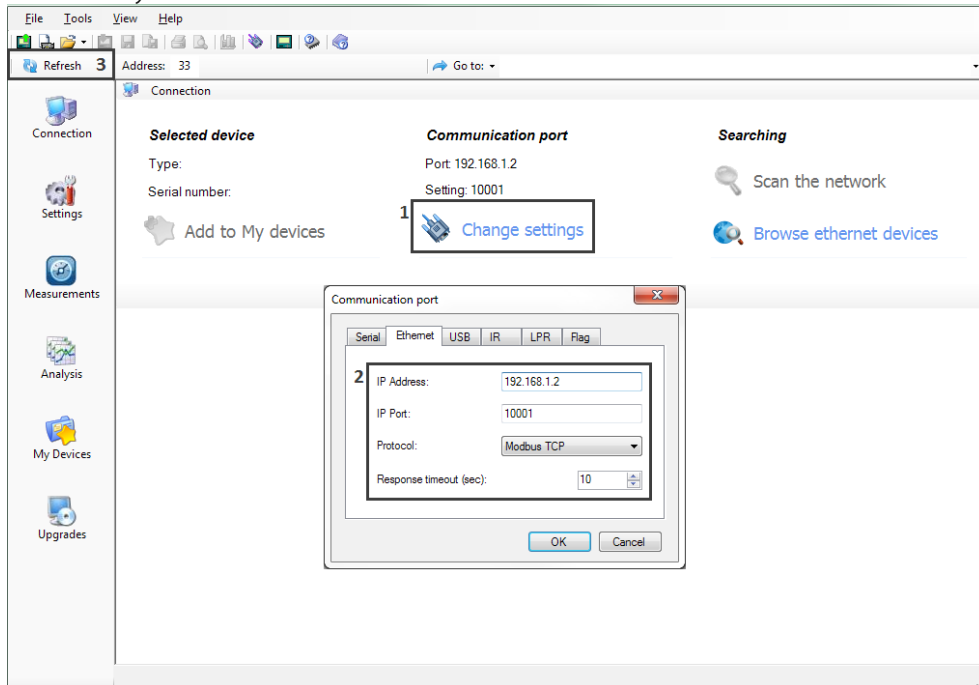

2. Add your device to My Devices:

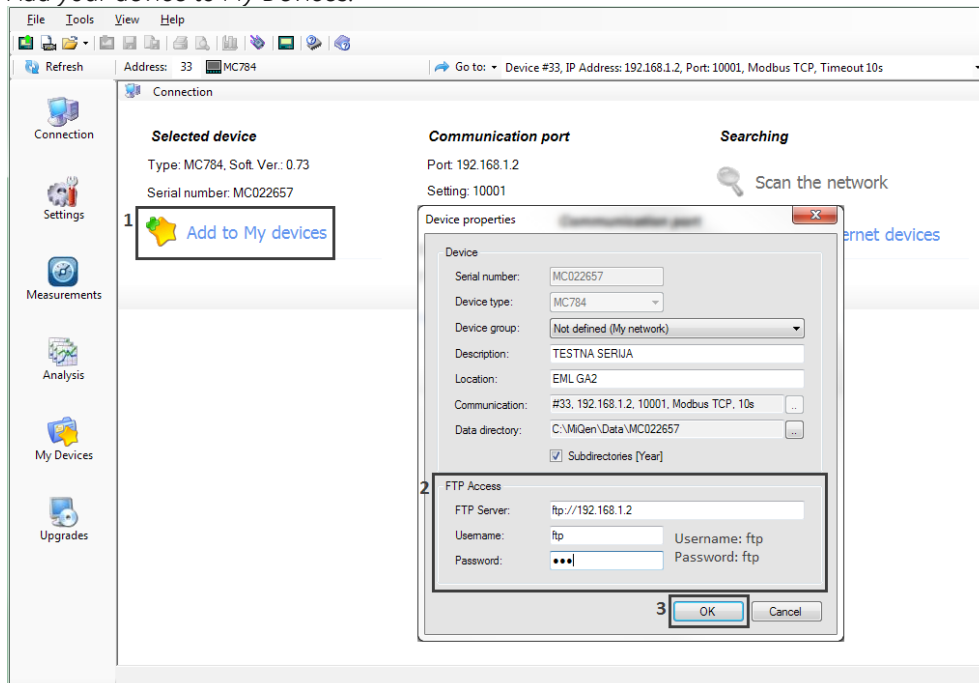

Username: ftp  
Password: ftp

3. My Devices tab will open (select your device by double-clicking on it):

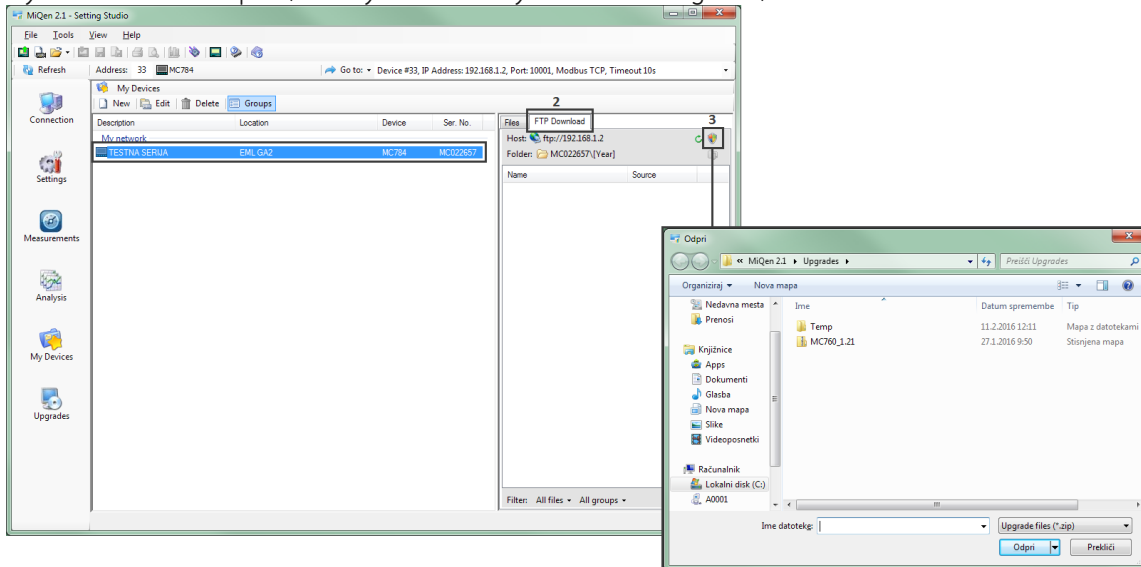

4. Browse to already downloaded upgrade file; Firmware/Linux OS/TFT - M365A only:

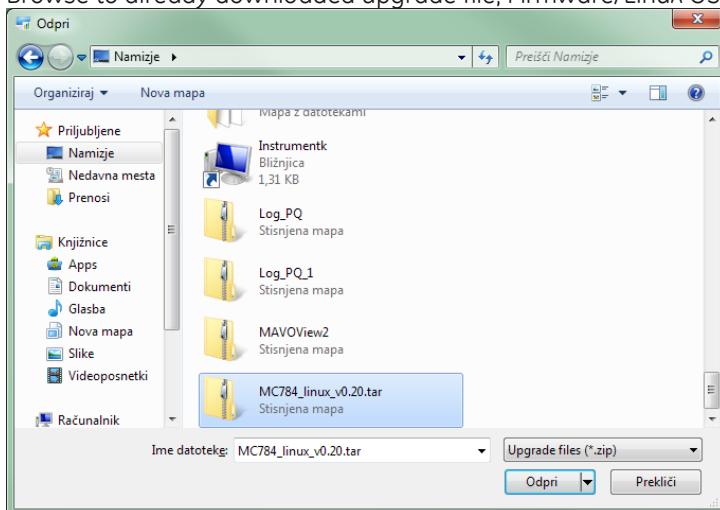

Click Open.

5. Following window will pop up:

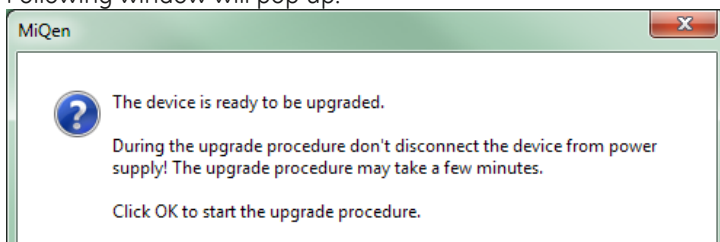

Click Ok to start upgrade procedure.

Upgrade file will get transferred to ftp. Upgrade procedure will initiate at first open window.

Check version:

**M365A:** TFT screen navigation - Main menu > Info:

Info	
General Memory	TYPE MC784 Waveform
	SERIAL NUMBER M4000000
	SOFTWARE VERSION FW: 1.00 TFT: 1.00 OS: 1.00
	HARDWARE VERSION A
	ACCURACY CLASS 0.5
	CALIBRATION VOLTAGE (V) 500
	9:23:51 HOME DOWN UP SELECT

**M365B:** LCD screen navigation - Main menu > Info > down arrow ↓:

Info
Ser.#: MC022657
S.ver: 1.00 Com: 1.00
H.ver: A M4
Date : 02.02.2017
Run : 204d 21h 31'
← Main menu

#### PLEASE NOTE

FW upgrade – The start of the upgrade procedure will show up on device screen after transferring the upgrade file to the device via FTP. It takes around 5 minutes to finish the upgrade procedure. Do not disconnect device during the upgrade. Communication to device may be lost during the upgrade.

OS upgrade – The upgrade procedure will run in the background, after transferring the upgrade file the device via FTP. It takes around 5 minutes to finish the upgrade procedure. Do not disconnect device during the upgrade. Communication to device may be lost during upgrade.

TFT upgrade (M365A only) – The start of the upgrade procedure will show up on device screen after transferring the upgrade file to the device via FTP. It takes around 5 minutes to finish the upgrade procedure. Do not disconnect device during the upgrade. Communication to device may be lost during the upgrade.

## Setting procedure

Before configuring ISTAT M365A/M365B with QDSP2.1 software, current settings should be read first. Reading is available either via communication or from a file (stored on a local disk). A setting structure that is similar to a file structure in an explorer is displayed in the left part of the QDSP2.1 setting window. Available settings of that segment are displayed in the right part by clicking any of the stated parameters.

#### PLEASE NOTE

Some settings may not be available due to unsupported measurements and/or functions that depend on the device type.

## General Settings

General settings are essential for measuring instruments. They are divided into four additional sublevels (Connection, Communication, Display and Security).

### Description and Location

Description is intended for easier recognition of a certain unit in a network.

It is especially used for identification of ISTAT M365A/M365B on which measurements are performed.

### Average interval

The averaging interval defines a refresh rate of measurements on display, communication. It is used also as averaging interval for minimum and maximum values stored in recorder and actual alarm value calculation for alarm triggering.

#### Average interval for measurements

The averaging interval defines a refresh rate of measurements on display, communication and analogue outputs. It also defines response time for alarms set to Normal response (see chapter Alarms).

- Shorter average interval means better resolution in minimum and maximum value in to recorded period detection and faster alarm response. Also data presented in display will refresh faster.

- Longer average interval means lower minimum and maximum value in recorded period detection and slower alarm response (alarm response can be delayed also with Compare time delay setting – See chapter Alarms). Also data on display will refresh slower.

Interval can be set from 0.1 to 5 s. Default value is 1 s.

#### Average interval for Min/Max values

The averaging interval for Min/Max values defines an interval on which values will be averaged to track Min and Max values. By choosing shorter interval also very fast changes in the network will be detected. Interval can be set form 1 to 256 periods.

#### PLEASE NOTE

This setting applies only for min. and max. values displayed on LCD and accessible on communication. These values are not used for storing into internal recorder.

### Language

Set language for display.

### Currency

Choose currency for evaluating energy cost. A currency designation consists of up to four letters taken from the English alphabet, numbers and symbols stated in table below.

English	A	B	C	D	E	F	G	H	I	J	K	L	M	N	O	P	Q	R	S	T	U	V	W	X	Y	Z
	a	b	c	d	e	f	g	h	i	j	k	l	m	n	o	p	q	r	s	t	u	v	w	x	y	z
Symbols		!	"	#	\$	%	&	'	(	)	*	+	,	-	.	/	0 to 9	:	;	<	=	>	?	@		

### Temperature unit

Choose a unit for temperature display. Degrees Celsius or degrees Fahrenheit are available.

### Date format

Set a date format for time stamped values.

## Date and Time

Set date and time of ISTAT M365A/M365B. Setting is important for correct memory operation, maximal values (MD), etc. If instrument is connected to one of supported time synchronization sources, date and time are automatically set.

## Time Synchronization Source

A synchronized real-time clock (RTC) is an essential part of any Class A analyzer for proper chronological determination and logging of various events. It is very important that every event and recorded measurement on

one device can be compared in time sequence with events and measurements on other devices such as the Power Quality Analyzer M365A/M365B.

For this purpose, Power Quality Analyzers M365A/M365B support a highly accurate internal RTC. However, a reference such as a time synchronization device should be used to implement periodic RTC synchronization.

### CAUTION

RTC synchronization is essential part of Class A instrument. If no proper RTC synchronization is provided, ISTAT M365A/M365B operates as Class S instrument.

This setting is used to choose primary synchronization source.

- NO synchronization (not advisable, see CAUTION above)
- NTP synchronization
- MODULE C synchronization

Synchronization status can be checked on display when set to INFO display.



Notification icon N shows successful NTP synchronization



Notification icon G shows successful GPS synchronization. If only 1pps signal is present (without date and time feed) notification icon G is present

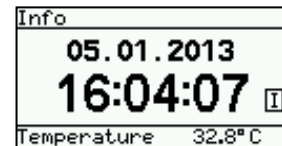

Notification icon I shows successful IRIG synchronization

## Time Zone

Set time zone in which device is mounted. Time zone influences internal time and time stamps. When UTC time is required, time zone 0 (GMT) should be chosen.

## Auto Summer/Winter Time

If Yes is chosen, time will be automatically shifted to a winter or a summer time, regarding the time that is momentarily set.

## Maximum Demand (MD) Calculation

The device provides maximum demand values from a variety of average demand values:

- Thermal function
- Fixed window
- Sliding windows (up to 15)

### Thermal function

A thermal function assures exponent thermal characteristic based on simulation of bimetal meters.

Maximal values and time of their occurrence are stored in ISTAT M365A/M365B. A time constant can be set from 1 to 255 minutes and is 6 times thermal time constant (t. c. = 6 × thermal time constant).

#### Example:

Mode: Thermal function  
 Time constant: 8 min  
 Running MD and maximal MD: Reset at 0 min

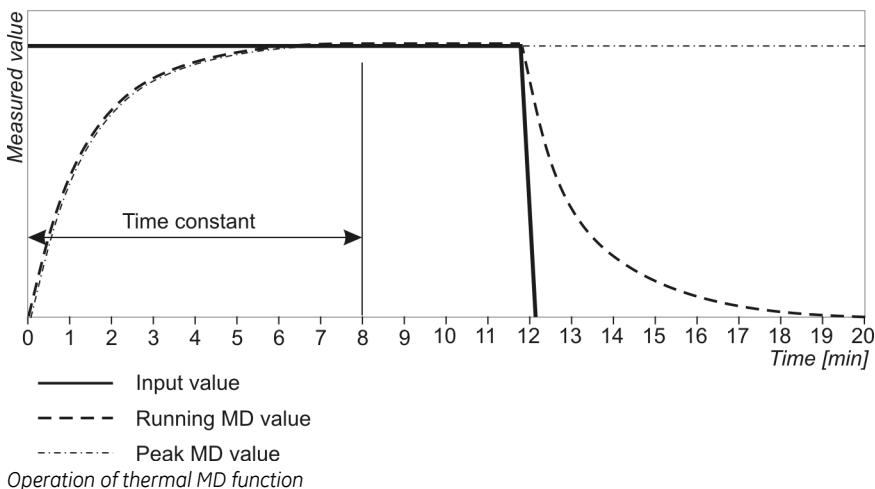

### Fixed window

A fixed window is a mode that calculates average value over a fixed time period. Time constant can be set from 1 to 255 min.

»Time into period« as displayed in QDSP2.1 – help tip actively shows the remaining time until the end of the period in which current MD and maximal MD from the last reset are calculated.

When displays for Pt(+/-), Qt(L/C), St, I1, I2 and I3 are updated, a new period and measurement of new average values are started. »TIME INTO PERIOD« then shows 0 of X min where X is Time Constant.

A new period also starts after a longer interruption of power supply (more than 1 s). If time constant is set to one of the values of 2, 3, 4, 5, 6, 10, 12, 15, 20, 30 or 60 minutes, »TIME INTO PERIOD« is set to such value that one of the following intervals will be terminated at a full hour. In other cases of time constants, »TIME INTO PERIOD« is set to 0.

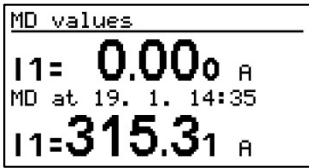

Figure above shows display of MD measurement for current I1. Running MD is displayed (0 mA), max. value of MD since last reset is displayed and its time of occurrence.

Reset Demands		
I1	474.62 mA	22.01.2016 09:28
I2	474.62 mA	22.01.2016 09:30
I3	474.70 mA	22.01.2016 09:29
P+	301.533 W	22.01.2016 09:30
P-	0.000 W	09.11.2012 01:00
Q-L	109.551 var	22.01.2016 09:29
Q-C	0.000 var	09.11.2012 01:00
S	320.80 VA	22.01.2016 09:28
9:56:41 MD-Dyn IO 1..4 Flick MD-Dyn MENU		

Figure above shows display of MD measurements. Max. value of MD since last reset is displayed and its time of occurrence.(Only supported by M365A).

**Example:**

Mode: Fixed window  
Time constant: 8 min.  
Running MD and maximal MD: Reset at 0 min.

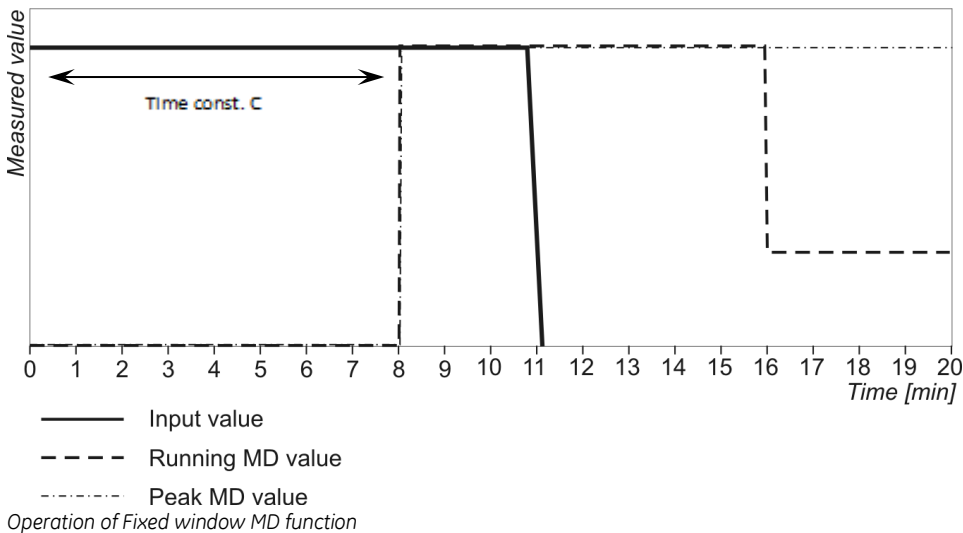

## Sliding windows

A mode of sliding windows enables multiple calculations of average in a period and thus more frequent refreshing of measuring results. Average value over a complete period is displayed. A running MD is updated every sub-period for average of previous sub-periods.

A number of sub-periods can be set from 2 to 15. A time constant can be set from 1 to 255 minutes.

A new period also starts after a longer interruption of power supply (more than 1 s). If time constant is set to one of the values of 2, 3, 4, 5, 6, 10, 12, 15, 20, 30 or 60 minutes, »TIME INTO PERIOD« is set to such value that one of the following intervals will be terminated at a full hour. In other cases of time constants, »TIME INTO PERIOD« is set to 0.

### Example:

Mode: Sliding windows

Time constant: 2 min.

No. of sub-periods: 4

Running MD and maximal MD: Reset at 0 min.

A complete period lasts for 8 minutes and consists of 4 sub-periods that are 2 minutes long. A running MD and a maximal MD are reset at 0 min. "Time into period" is data for a sub period so that the values for a running MD and a maximal MD are refreshed every two minutes. After 4 sub-periods (1 complete period) the oldest sub period is eliminated when a new one is added, so that average (a window) always covers the last 4 sub-periods.

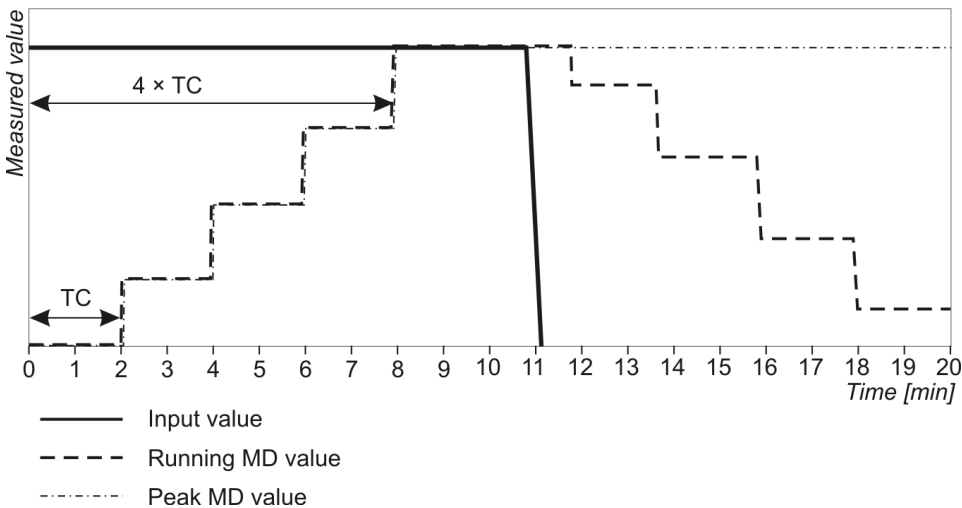

Operation of sliding window MD function

## Maximum Demand Reset Mode

This setting defines a mode of resetting Max demand values. It can be set to:

**Manual:** User resets max demand value with keypad or setting software.

### Automatic:

- Daily: every day at 00:00,
- Weekly: on Monday at 00:00,
- Monthly: the first day in a month at 00:00,
- Yearly: the first day in a year 1.1. at 00:00

## Min/Max Reset Mode

This setting defines a mode of resetting stored Min/Max values. It can be set to.

**Manual:** User resets min/max values with keypad or setting software.

**Automatic:**

- Daily: every day at 00:00,
- Weekly: on Monday at 00:00,
- Monthly: the first day in a month at 00:00,
- Yearly: the first day in a year 1.1. at 00:00

## Starting Current for PF and PA (mA)

All measuring inputs are influenced by noise of various frequencies. It is more or less constant and its influence to the accuracy is increased by decreasing measuring signals. It is present also when measuring signals are not present or are very low. It causes very sporadic measurements.

This setting defines the lowest current that allows regular calculation of Power Factor (PF) and Power Angle (PA).

The value for starting current should be set according to conditions in a system (level of noise, random current fluctuation ...)

## Starting current for all powers (mA)

Noise is limited with a starting current also at measurements and calculations of powers. The value for starting current should be set according to conditions in a system (level of noise, random current fluctuation ...)

## Starting voltage for all Powers (V)

Noise is limited with a starting voltage also at measurements and calculations of powers. Until voltage reaches user defined starting voltage limit, all powers are set to 0. Using three wire electrical connections, virtual phase voltage is used in calculations.

## Starting voltage for SYNC

ISTAT M365A/M365B needs to synchronize its sampling with measuring signals period to accurately determine its frequency. For that purpose, input signal has to be large enough to be distinguished from a noise.

If all phase voltages are smaller than this (noise limit) setting, instrument uses current inputs for synchronization. If also all phase currents are smaller than Starting current for PF and PA setting, synchronization is not possible and frequency displayed is 0.

The value for starting voltage should be set according to conditions in a system (level of noise, random voltage fluctuation ...)

## Harmonics calculation

Relative harmonic values can be different according to used base unit. According to requirements relative harmonics can be calculated as:

- percentage of RMS signal value (current, voltage) or
- percentage of the fundamental (first harmonic).

## Reactive power & energy calculation

Harmonic distortion can significantly influence reactive power and energy calculation. In absence of harmonic distortion both described methods will offer the same result. In reality harmonics are always present. Therefore it is up to project requirements, which method is applicable.

User can select between two different principles of reactive power and energy calculation:

### Standard method:

With this method a reactive power and energy are calculated based on assumption that all power (energy), which is not active, is reactive.

$$Q_2 = S_2 - P_2$$

This means also that all higher harmonics (out of phase with base harmonic) will be measured as reactive power (energy).

### Displacement method:

With this method, reactive power (energy) is calculated by multiplication of voltage samples and by 90° displaced current samples.

$$Q = U \times I|_{+90^\circ}$$

With this method, reactive power (energy) represents only true reactive component of apparent power (energy).

## LCD navigation

### M365B

Main menu
Measurements
<b>Settings</b>
Resets
Info
Installation
14.5.2015      16:53:36

→

Settings
<b>General</b>
Date & Time
Connection
Communication
LCD
Security
Energy
Inputs/Outputs
⇐ Main menu

 Main menu > Settings > General > Language / Currency / Temperature unit / MD mode / MD time constant / Average interval / Min/Max reset mode

 Main menu > Settings > Date & Time > Date / Time / Date format / automatic S/W time

## M365A

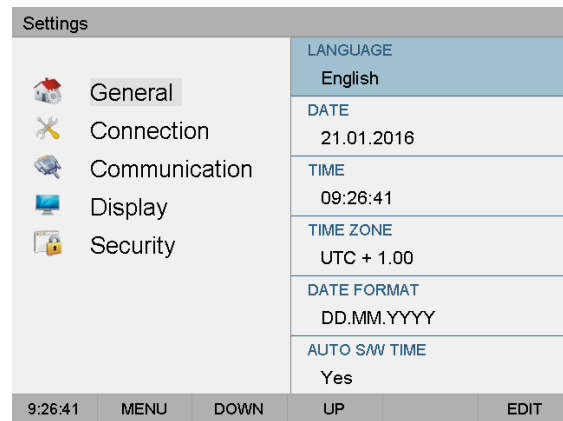
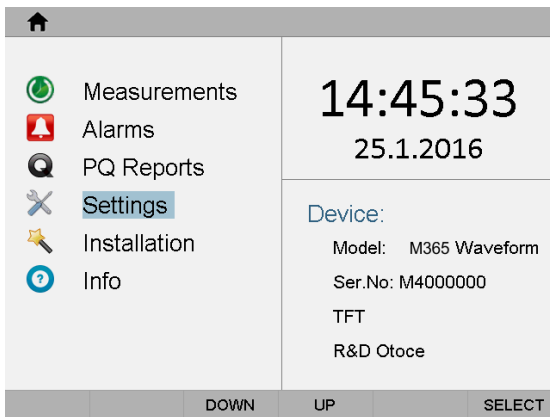

Main menu > Settings > General:

- LANGUAGE
- DATE
- TIME
- TIME ZONE
- DATE FORMAT
- AUTO S/W TIME

## Connection

### CAUTION

Connections settings need to be correct otherwise measurements may not be valid.

## Connection mode

When connection is selected, load connection and the supported measurements are defined.

## Setting of current and voltage ratios

Before setting current and voltage ratios it is necessary to be familiar with the conditions in which ISTAT M365A/M365B will be used. All other measurements and calculations depend on these settings. Up to five decimal places can be set (up / down). To set decimal point and prefix (up / down) position the cursor (left / right) to last (empty) place or the decimal point.

Aux CT transformer ratios can be set separately from phase CT ratios since Aux CT could differ from phase CTs.

Range of CT and VT ratios:

Settings range	VT primary	VT secondary	CT, Aux CT primary	CT, Aux CT secondary
Max value	1638,3 kV	13383 V	1638,3 kA	13383 A
Min value	0,1 V	0,1 V	0,1 A	0,1 A

## Neutral line Primary/Secondary current (A)

Primary/Secondary current of neutral line current transformer.

## Used voltage/current range (V/A)

Setting of the range is connected with all settings of alarms, analogue outputs and a display (calculation) of energy and measurements recording, where 100% represents 500 V. In case of subsequent change of the range, alarms settings shall be correspondingly changed, as well.

### CAUTION

In making changes, ensure that subsequent alarm and analogue output settings are also correspondingly changed as well.

Previously recorded values will not be valid after changing voltage and/or current range.

## Frequency nominal value (Hz)

Nominal frequency range can be selected from a set of predefined values. A valid frequency measurement is within the range of nominal frequency  $\pm 32$  Hz.

This setting is used for alarms and recorders only.

## Max. demand current for TDD (A)

Select maximum current (CT or fuse rating) at a point of instrument connection for proper TDD calculation. TDD is unlike THD a measure of harmonics relative to fixed value of max. demand current. Therefore TDD is a demand independent measure of current harmonics.

## Wrong connection warning

If all phase currents (active powers) do not have same sign (some are positive and some negative) and/or if phase voltages and phase currents are mixed, the warning will be activated if this setting is set to YES. This warning is seen only on remote display.

## Energy flow direction

This setting allows manual change of energy flow direction (IMPORT to EXPORT or vice versa) in readings tab. It has no influence on readings sent to communication or to memory.

## CT connection

If this setting is set to REVERSED it has the same influence as if CT's would be reversely connected. All power readings will also change its sign.

This setting is useful to correct wrong CT connections.

## LCD navigation

### M365B

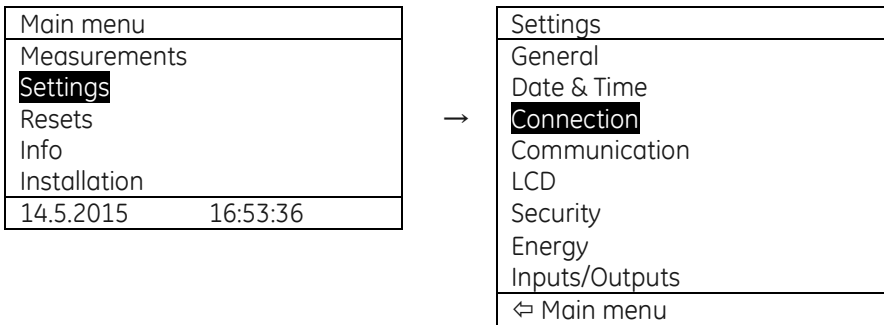

☰ Main menu > Settings > Connection > Connection mode

☰ Main menu > Settings > Connection > VT primary/VT secondary/CT primary/CT secondary/Aux CT primary/Aux CT secondary

### M365A

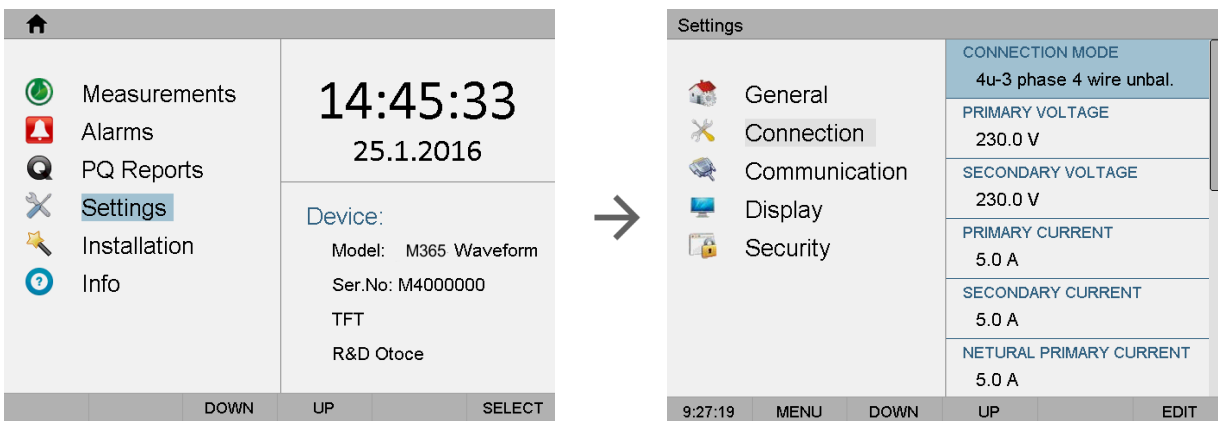

Main menu > Settings > Connection:

- CONNECTION MODE
- PRIMARY VOLTAGE
- SECONDARY VOLTGE
- PRIMARY CURRENT
- SECONDARY CURRENTT
- NEUTRAL PRIMARY CURRENT
- NEUTRAL SECONDARY CURRENT
- USED VOLTAGE RANGE
- USED CURRENT RANGE

## Communication

### USB Communication

There is no special setting for USB communication. For more detailed information how to handle ISTAT M365A/M365B with USB communication use Help section in QDSP2.1 software.

---

**⚠ PLEASE NOTE**

ISTAT M365A/M365B supports only a single communication input (USB or Ethernet) at a time when using primary communication port COM1. USB communication has priority. If communication using Ethernet is in progress, do not connect to USB since it will terminate Ethernet connection. When USB cable is unplugged from the device Ethernet communication is again available.

---

---

**⚠ PLEASE NOTE**

When ISTAT M365A/M365B is connected to a PC through USB communication for the first time, it will get recognized by windows environment and a driver will get automatically installed. With driver installed, USB is redirected to a serial port, which should be selected when using QDSP2.1 software. If experiencing problems with driver installation you can find drivers in QDSP2.1 installation folder – in subfolder Drivers (example: C (root):\Program Files (x86)\QDSP2.1 2.1\Drivers), for manual install.

---

### Ethernet communication

Ethernet communication is used for connection of device to the Ethernet network for remote operation. Each ISTAT M365A/M365B has its own MAC address that at some cases needs to be provided and is printed on the label on the device.

### MAC Address

Read only information about ISTAT M365A/M365B MAC address.

### Device Address

ISTAT M365A/M365B Address: Device address is important when user is trying to connect to device via QDSP2.1 software. Usable range of addresses is from 1 to 247. Default address number is 33. (Not important when Ethernet communication is used.)

### Firmware version

Read only information about communication module firmware version. (M365A/M365B – Read only information about Linux OS module firmware version)

### IP Address

Communication interface should have a unique IP address in the Ethernet network. Two modes for assigning IP are possible:

**Fixed IP address:**

In most installations a fixed IP address is required. A system provider usually defines IP addresses. An IP address should be within a valid IP range, unique for your network and in the same subnetwork as your PC.

**DHCP:**

Automatic (dynamic) method of assigning IP addressed (DHCP) is used in most networks. If you are not sure if DHCP is used in your network, check it at your system provider.

## IP Hostname

It is the nickname that is given to ISTAT M365A/M365B. Hostnames may be simple names consisting of a single word or phrase or they may be structured. The setting is used in automatic (DHCP) mode only.

## Local port

When using Ethernet communication ISTAT M365A/M365B has opened two local ports.

- Fixed port number 502, which is a standard MODBUS port. ISTAT M365A/M365B allows multiple connections to this port.
- User defined port. Any port number is allowed except reserved ports (table below). Only a single connection is allowed to this port. When this port is used all other connections (including connection to port 502) are disabled. This is a terminal type of connection.

Terminal type of connection is used when due to a performed function other connections are not allowed. This is the case when firmware update is performed. In other cases it is advised to use port 502.

When port 502 is used a remote application(s) can access device regardless the setting for *Local Port* in a device. This setting is applicable only when terminal access is required.

### Reserved TCP Port numbers

Important port numbers	Function
1 – 1024, 9999, 30718, 33333	Reserved numbers!
502	Standard MODBUS port – fixed
33333	UDP port used for Device Discovery Service

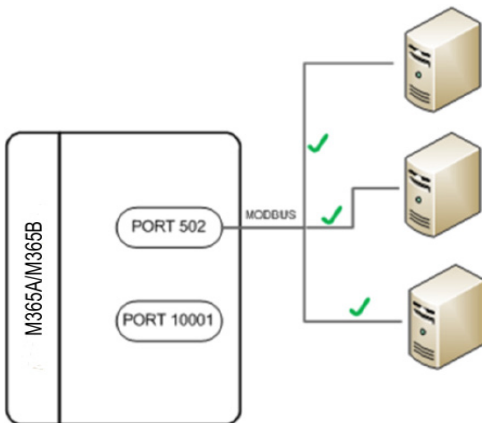

*Multiple connections to a device are possible when port 502 (special MODBUS port) is used*

### Port 502

Is standardized port to communicate with the device via MODBUS/TCP communication protocol and is fixed. Communication via this port allows multiple connections to the device. Communication over this port does not block any other traffic.

### Port 33333

This UDP port is reserved for Discovery Service, a service run by QDSP2.1 software, to discover devices connected in to local Ethernet communication network.

### Other available Ports

Other, allowed TCP ports, are acting as terminal port and when connected to it, it blocks all other connections until it is released.

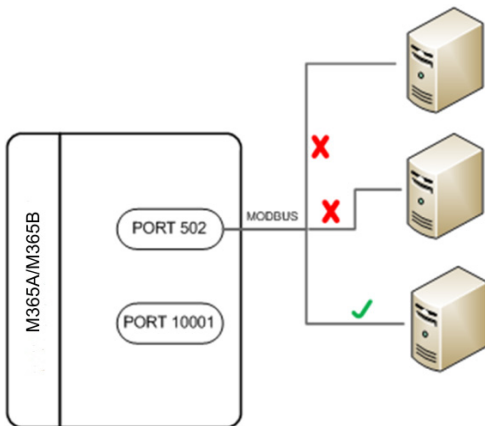

When any other allowed port is used only a single connection is possible

## Subnet Mask

It is used to determine what subnet an IP address belongs to.

## Gateway Address

It is a gateway that connects separate network segments (LAN, WAN or internet).

## NTP Server

IP address of a NTP server used for time synchronization of ISTAT M365A/M365B.

NTP can usually maintain time to within tens of milliseconds over the public Internet, but the accuracy depends on infrastructure properties - asymmetry in outgoing and incoming communication delay affects systematic bias.

---

### **⚠ PLEASE NOTE**

---

It is recommended that dedicated network rather than public network is used for synchronization purposes.

---

Factory settings of Ethernet communication are:

IP Address	DHCP (automatically)
TCP Port (Terminal Port)	10001
Subnet Mask	255.255.255.0

- Response Time (sec)

## Communication modes

ISTAT M365A/M365B supports two communication modes to suit all demands about connectivity and flexibility. Standard POLL communication mode is used for most user interaction purposes in combination with monitoring and setting software QDSP2.1, SCADA systems and other MODBUS oriented data acquisition software.

### POLL communication mode

This is most commonly used communication mode. It services data-on-demand and is therefore suitable for direct connection of setting and / or supervising software to a single device or for a network connection of multiple devices, which requires setting up an appropriate communication infrastructure.



Data is sent from device when it is asked by external software according to MODBUS RTU or MODBUS TCP protocol. This type of communication is normally used for a real-time on-demand measurement collection for control purposes.

To set up POLL communication mode, only basic communication settings are required according to communication type (serial, USB, ETHERNET).

## LCD navigation

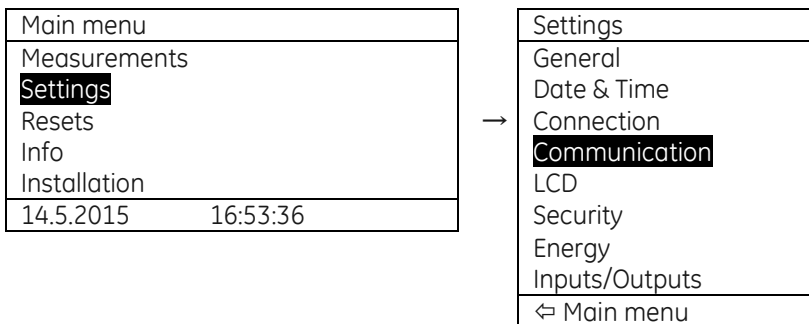
### M365B



-  Main menu > Settings > Communication
-  Main menu > Settings > Communication
-  Main menu > Settings > Communication > (all settings are not supported on keypad)

## M365A

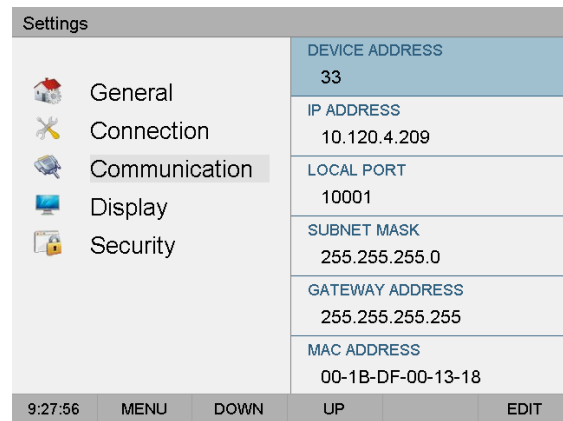
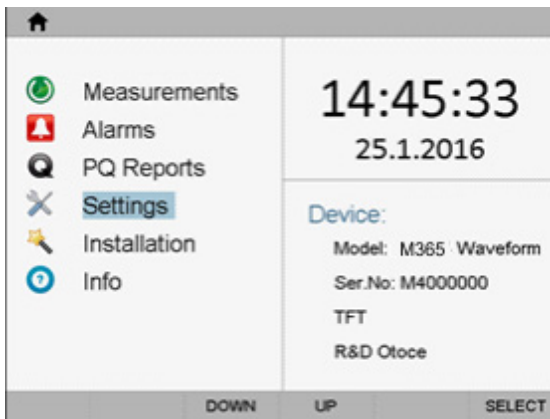

Main menu > Settings > Communication:

- DEVICE ADDRESS
- IP ADDRESS
- LOCAL PORT
- SUBNET MASK
- GETWAY ADDRESS
- MAC ADDRESS

## Display

### Contrast/Black light intensity

A combination of setting of the contrast and back light defines visibility and legibility of a display. Display settings shall be defined in compliance with the conditions in which it will be monitored. Economizing mode switches off back light according to the set time of inactivity.

### Saving mode (min)

Defines the time in minutes, for the instrument to get into energy saving mode (backlight off). Enter value 0 if you don't want to use energy saving mode.

### Demo cycling period (sec)

For demonstration purposes it is useful for device to automatically switch between different displays of measurements.

This setting defines time in seconds for each displayed screen of measurements.

### Custom screen 1/2/3

For easier and faster survey of measurements that are important for the user, three settings of customized screens are available. Each customized screen displays three measurements. When setting customized screens the designations are displayed in shorter form, with up to 4 characters. For survey of all designations see chapter Selection of available quantities.

#### Example:

Customized screen 1	Customized screen 2	Customized screen 3	Combined customized screen 4
U1	I <sub>TOT</sub>	φ <sub>1-3_RMS</sub>	U1
U <sub>P-P_avg</sub>	I <sub>NM</sub>	f	U <sub>P-P_avg</sub>
U <sub>UNBALANCE</sub>	I <sub>AVG</sub>	THD-I1	U <sub>UNBALANCE</sub>
-	-	-	I <sub>TOT</sub>
-	-	-	I <sub>NM</sub>

#### PLEASE NOTE

Customized screens defined here are selected in menu.

 Main menu > Measurements > Present values > Custom

Setting can be made only for 3 customized screens. 4<sup>th</sup> customized screen is showing 5 parameters, three from Customized screen 1 and first two from Customized screen 2. See example above.

#### PLEASE NOTE

Custom screens for M365A can only be set in QDSP2.1 software. Customized screens defined in QDSP2.1 are then selected in menu:

 General > Display > Custom Screen 1 /2/3

Setting can be made only for 3 customized screens.

## LCD navigation

## M365B

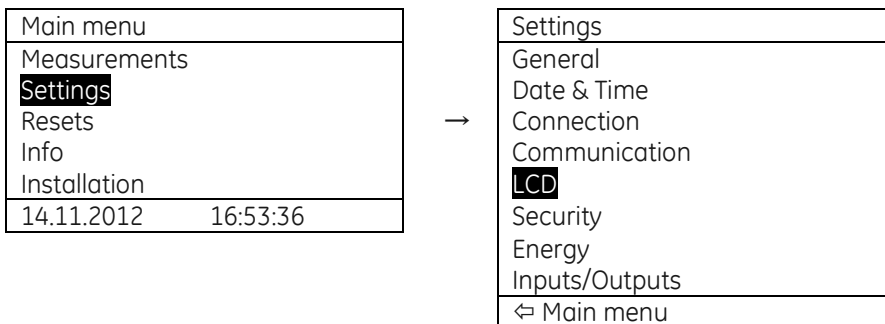

- 🔊 Main menu > Settings > LCD > Contrast / Back light / Back light time off
- 🔊 Main menu > Settings > LCD > Demo cycling period
- 🔊 Main menu > Settings > LCD > Custom screen 1 / 2 / 3 / (4)

## M365A

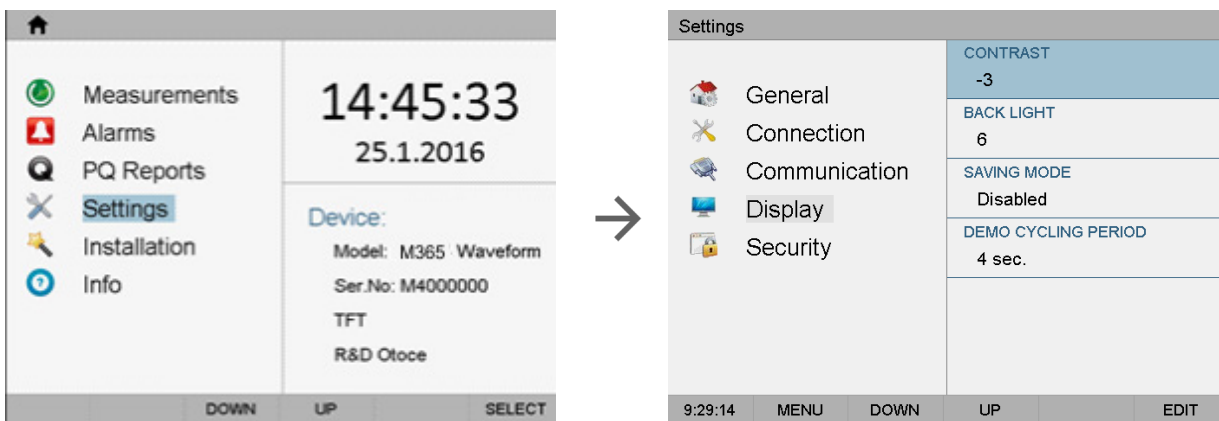

Main menu > Settings > General:

- CONTRAST
- BACK LIGHT
- SAVING MODE
- DEMO CYCLING PERIOD

## Security

Settings parameters are divided into four groups regarding security level: PL0 >password level 0), PL1 >password level 1), PL2 >password level 2) and BP >a backup password).

---

### PLEASE NOTE

---

A serial number of ISTAT M365A/M365B is stated on the label and is also accessible with QDSP2.1 software.

---

### Password - Level 0 >PL0)

Password is not required.

Available settings:

- language
- contrast and
- LCD back light.

### Password - Level 1 >PL1)

Password for first level is required.

Available settings:

- RTC settings
- Energy meters reset
- Max. Demand reset
- Active tariff setting

### Password - Level 2 >PL2)

Password for second level is required. Available settings:

- All settings are available

### A Backup Password->BP)

A backup password >BP) is used if passwords at levels 1 >PL1) and 2 >PL2) have been forgotten, and it is different for each device >depending on a serial number of the device). The BP password is available in the user support department in GE Vernova, and is entered instead of the password PL1 or/and PL2. Do not forget to state the device serial number when contacting the personnel in GE Vernova.

### Password lock time >min)

Defines the time in minutes for the instrument to activate password protection. Enter value 0 if you want to use manual password activation.

### Password setting

A password consists of four letters taken from the British alphabet from A to Z. When setting a password, only the letter being set is visible while others are hidden.

A password of the first >PL1) and the second >PL2) level is entered, and time of automatic activation is set.

### Password modification

A password is optionally modified; however, only that password can be modified to which the access is unlocked at the moment.

### Password disabling

A password is disabled by setting the "AAAA" password.

**PLEASE NOTE**

A factory set password is "AAAA" at both access levels >L1 and L2). This password does not limit access.

## Password and language

Language change is possible without password input. When language is changed from or to Russian, character transformation has to be taken in to account. Character transformation table >English or Russian alphabet) is stated below.

English	A	B	C	D	E	F	G	H	I	J	K	L	M	N	O	P	Q	R	S	T	U	V	W	X	Y	Z
Russian	А	Б	В	Г	Д	Е	Ж	З	И	Й	К	Л	М	Н	О	П	Р	С	Т	У	Ф	Х	Ц	Ч	Ш	Щ

**PLEASE NOTE**

Power Quality Analyzer M365A does not support Russian characters.

## LCD navigation

### M365B

Main menu
Measurements
<b>Settings</b>
Resets
Info
Installation
14.5.2015      16:53:36



Settings
General
Date & Time
Connection
Communication
LCD
<b>Security</b>
Energy
Inputs/Outputs
⇐ Main menu

☰ Main menu > Settings > Security > Password level 1 / Password level 2 / Password lock time / Lock instrument / Unlock instrument

## M365A

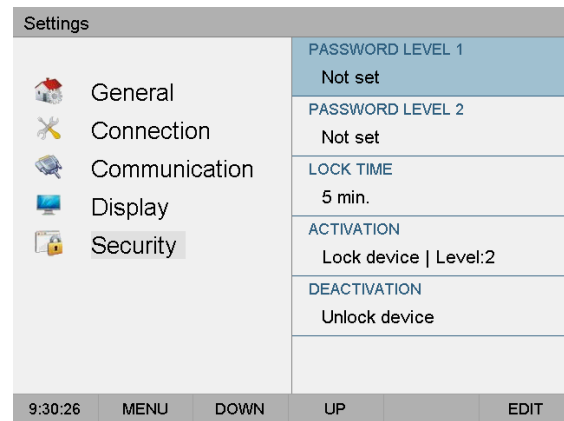
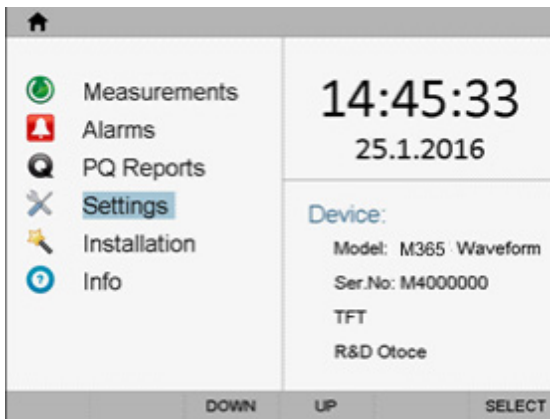

Main menu > Settings > General:

- PASSWORD LEVEL 1
- PASSWORD LEVEL 2
- LOCK TIME
- ACTIVATION
- DEACTIVATION

## Energy

### WARNING

Before modification, all energy counters should be read or if energy values are stored in recorders, recorder should be read with QDSP2.1 software to assure data consistency for the past.

After modification of energy parameters, the energy meters (counters) should be reset. All recorded measurements from this point back might have wrong values so they should not be transferred to any system for data acquisition and analysis. Data stored before modification should be used for this purpose.

## Active Tariff

When active tariff is set, one of the tariffs is defined as active; switching between tariffs is done either with a tariff clock or a tariff input. For the operation of the tariff clock other parameters of the tariff clock that are accessible only via communication must be set correctly.

## Common Energy Counter Resolution

Common energy exponent defines minimal energy that can be displayed on the energy counter. On the basis of this and a counter divider, a basic calculation prefix for energy is defined (-3 is  $10^{-3}\text{Wh} = \text{mWh}$ , 4 is  $10^4\text{Wh} = 10 \text{ kWh}$ ). A common energy exponent also influences in setting a number of impulses for energy of pulse output or alarm output functioning as an energy meter.

Define common energy exponent as recommended in table below, where counter divider is at default value 10. Values of primary voltage and current determine proper Common energy exponent.

Current Voltage	1 A	5 A	50 A	100 A	1000 A
110 V	100 mWh	1 Wh	10 Wh	10 Wh	100 Wh
230 V	1 Wh	1 Wh	10 Wh	100 Wh	1 kWh
1000 V	1 Wh	10 Wh	100 Wh	1 kWh	10 kWh
30 kV	100 Wh	100 Wh	1 kWh	10 kWh	10 kWh *

\* – Individual counter resolution should be at least 100.

## Common Energy Cost Exponent

Setting enables resolving the cost display. On the basis of this and a counter divider constant, a basic calculation prefix for energy cost is defined.

## Counter divider

The counter divider additionally defines precision of a certain counter, according to settings of common energy exponent.

An example for 12.345kWh of consumed active energy:

Common energy exponent	0	2	2
Counter divider	1	1	100
Example of result, displayed	12.345 kWh	12.3 kWh	0.01 MWh

## Common Tariff Price Exponent

Exponent and price represent energy price (active, reactive, common) in a tariff. The tariff price exponent is used for recording the price without decimal places. For example, to set a price for tariff 1 to 0,1567 €/kWh, the number in Price for energy in tariff 1 field should be 1567 and Common tariff price exponent should be -4 ( $1567 \times 1\text{E-}4 = 0,1567$ )

An example for 12.345kWh of consumed active energy in the first tariff (price 0,1567 €/kWh):

Common Energy Counter Resolution	1 Wh	100 Wh	100 Wh
Individual Energy Counter Resolution	1	1	100
Common Energy Cost Exponent	-3	-2	0
Common Tariff Price Exponent	-4	-4	-4
Price for energy in Tariff 1	1567	1567	1567
Unit	EUR	EUR	EUR
Example of result, displayed	12.345 kWh 1,934 EUR	12.3 kWh 1.93 EUR	0.01 MWh 1 EUR

## 1 kWh Price in Tariff (1,2,3,4)

The price for 1kWh active energy in selected tariff. The entered value is multiplied with tariff price exponent: Tariff price = Price \* 10 ^ Exponent.

## 1 kvarh Price in Tariff (1,2,3,4)

The price for 1 kvarh reactive energy in selected tariff. The entered value is multiplied with tariff price exponent: Tariff price \* 10 ^ Exponent.

## 1 kVAh Price in Tariff (1,2,3,4)

The price for 1 kvarh reactive energy in selected tariff. The entered value is multiplied with tariff price exponent: Tariff price \* 10 ^ Exponent.

## LED Energy Counter

Set one of four different Energy counters, which are connected to LED. (There is no LED indication on M365A)

## LED Number of pulses

Number of pulses per energy unit for LED. (There is no LED indication on M365A)

## LED Pulse Length (ms)

Pulse length for LED in milliseconds. (There is no LED indication on M365A)

## Measured Energy

For each of eight (8) counters different measured quantities can be selected. User can select from a range of predefined options referring to measured total energy or energy on single phase. Or can even select its own option by selecting appropriate quantity, quadrant, absolute or inverse function.

To energy counter also pulse / digital input can be attached. In this case Energy counter counts pulses from an outside source (water, gas, energy... meter).

## Individual counter Resolution

The individual counter resolution additionally defines precision of a certain counter, according to settings of common energy counter resolution.

## Tariff Selector

Defines tariffs where counter is active.

## Tariff Clock

Basic characteristics of a program tariff clock:

- 4 tariffs (T1 to T4)
- Up to 4 time spots in each Day program for tariff switching
- Whichever combination of valid days in a week or holidays for each program
- Combining of day groups (use of over 4 time spots for certain days in a week)
- Separate settings for 4 seasons a year
- Up to 20 settable dates for holidays

Day program sets up to 4 time spots (rules) for each day group in a season for tariff switching. A date of real time clock defines an active period. An individual period is active from the period starting date to the first next date of the beginning of other periods.

The order of seasons and starting dates is not important, except when two dates are equal. In that case the season with a higher successive number has priority, while the season with a lower number will never be active.

If no starting date of a season is active, the active period is 1.

If the present date is before the first starting date of any period, the period is active with the last starting date.

Example of settings:

Season	Season start day
Season 1:	15.02
Season 2:	30.10
Season 3:	-
Season 4:	01.06
Date	Active season
01.01. - 14.02.	2 (last in the year)
15.02. - 31.05.	1
01.06. - 29.10.	4
30.10. - 31.12.	2

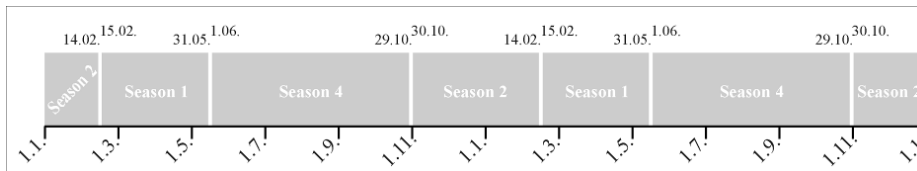

**Days in a week and selected dates for holidays** define time spots for each daily group in a period for tariff switching. Dates for holidays have priority over days in a week.

When the real time clock date is equal to one of a date of holidays, tariff is switched to holiday, within a period of active daily group with a selected holiday.

If there is no date of holidays that is equal to the real time clock date, all daily groups with the selected current day in a week are active.

Several daily groups can be active simultaneously, which enables more than 4 time spots in one day (combine of day programs).

If the time spot is not set for a certain day, tariff T1 is chosen.

**Time of a real time clock** defines an active tariff regarding currently active day program. A selected tariff T1 to T4 of individual time spot is active from the time of the time spot to the first next time of the remaining time spots.

The order of time spots is not important, except when two times are equal. In that case the time with a higher successive number has priority (if several time spots are active, times of higher time spots have higher successive numbers), while the time spot with a lower number will never be active.

If current time is before the first time of any time spot of active spots, the time spot with the last time is chosen.

If no time spot of active programs is valid, tariff T1 is chosen.

Time selected tariff T1 to T4 or fixed selected tariff (via communication) defines activity of an energy counter.

## Holidays/Holiday date 1-20

Year days (holidays) with the special cost management rules.

## LCD navigation

### M365B

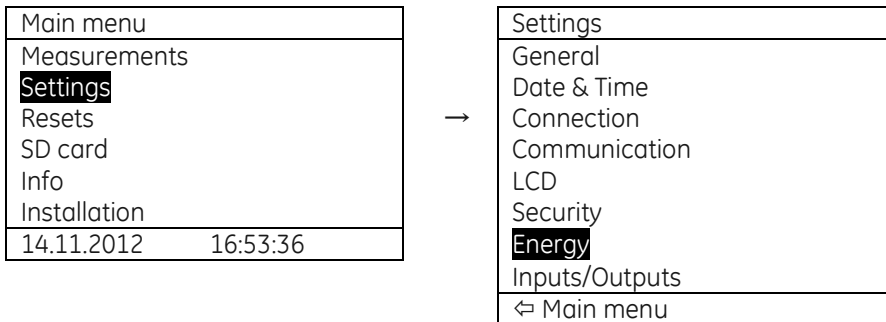

Main menu > Settings > Energy > Active tariff



Main menu > Settings > Energy > Common en. exponent

Example of display for selected Active tariff:



Main menu > Info OK ↓↓↓ ⇒

Tariff status
Season: 1
Day Programs
P1 -- -- --
Tariff: T3
↩ Info

Or

Tariff status
Selected: T2
↩ Info

Or

Tariff status
Tariff input
Selected: T1
↩ Info

### M365A

Energy settings for M365A can only be set in QDSP2.1 software. Using device TFT display, you can check energy measurements and which tariff is active by following steps below:

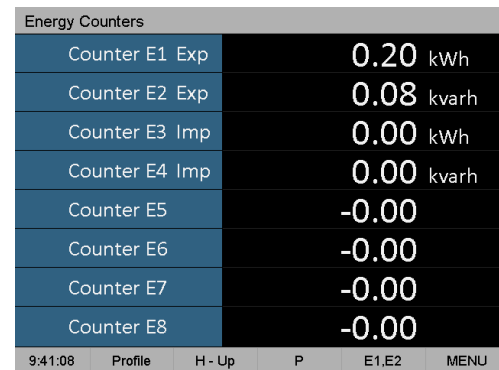
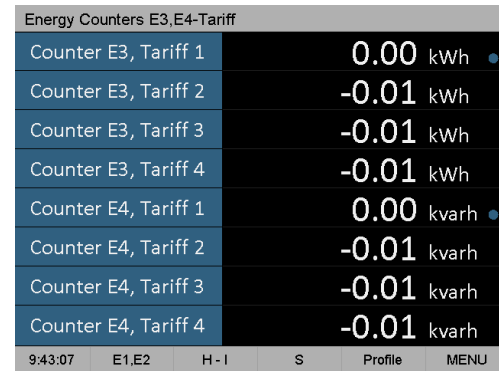
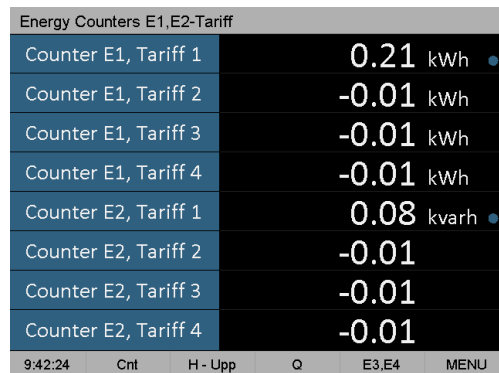
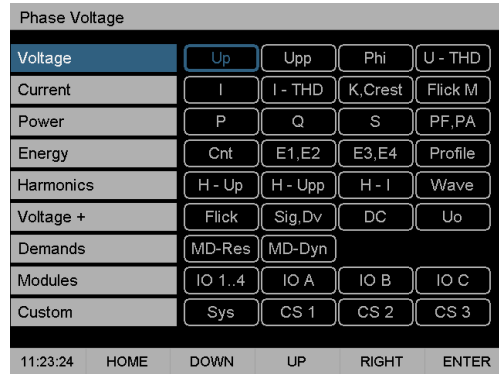
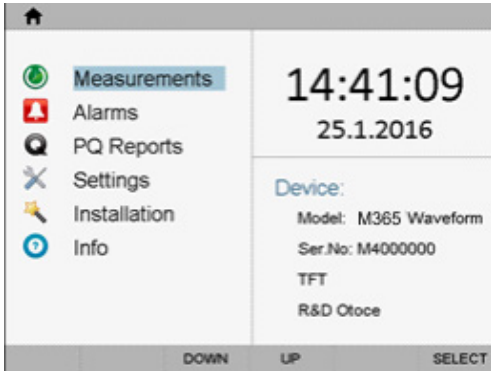

---

## Inputs and outputs

I/O functionality is a powerful tool of ISTAT M365A/M365B using various I/O modules device can be used not only for monitoring main electrical quantities but also for monitoring process quantities (temp., pressure, wind speed...) and for various control purposes. ISTAT M365A/M365B can be equipped with different I/O modules with different functionality. For its technical specifications, see chapter Technical data.

### Options for I/O module 1 and 2

**Inputs:**

- DC current analogue input
- DC voltage analogue input
- Resistance (temperature) analogue input
- Pulse input
- Digital input
- Tariff input

Tariff and digital input can be ordered as three different hardware types with different voltage level, but the same functionality.

**Outputs:**

- Analogue output
- Pulse output (solid state)
- Relay output (relay)
- Bistable alarm output (bistable relay)
- Watchdog / Relay output

All modules have double input or output, except for a Bistable alarm output module and Watchdog output module. All modules with a double input or output are in QDSP2.1 software presented as two separate modules.

An alarm output and a pulse output can also be selected via a keyboard. When selecting settings of energy and quadrants for a certain counter, only present selection is possible, while more demanding settings are accessible via communication. For other modules, information on a built-in module is available via LCD.

### Options for I/O module 3 and 4:

**Inputs:**

- DC current analogue input
- DC voltage analogue input
- Resistance (temperature) analogue input
- Digital input
- Pulse input

Digital input can be ordered as three different hardware types with different voltage level, but the same functionality.

**Outputs:**

- Analogue output
- Pulse output (solid state)
- Relay output (relay)
- Bistable alarm output (bistable relay)
- Watchdog / Relay output

All modules have double input or output, except for a Bistable alarm output module and Watchdog output module. All modules with a double input or output are in QDSP2.1 software presented as two separate modules.

An alarm output and a pulse output can also be selected via a keyboard. When selecting settings of energy and quadrants for a certain counter, only present selection is possible, while more demanding settings are accessible via communication. For other modules, information on a built-in module is available via LCD.

### Analogue input module

Three types of analogue inputs are suitable for acquisition of low voltage DC signals from different sensors. According to application requirements it is possible to order current, voltage or resistance (temperature) analogue input. They all use the same output terminals.

QDSP2.1 software allows setting an appropriate calculation factor, exponent and required unit for representation of primary measured value (temperature, pressure, flux ...)

Signals from Analogue input can also be stored in built-in memory of a. They can also be included in alarm function (see chapter *Alarms*).

#### DC current range:

Range setting allows bipolar  $\pm 20$  mA max. input value

#### DC voltage range:

Range setting allows bipolar  $\pm 10$  V max. input value

#### Resistance / temperature range:

Range setting allows 0 ... 2000 $\Omega$  max. input value

It is also possible to choose temperature sensor (PT100 or PT1000) with direct translation into temperature (-200°C to +850°C). Since only two-wire connection is possible it is recommended that wire resistance is also set, when long leads are used.

### Pulse input module

Module has no settings. It is general purpose pulse counter from external meters (water, gas, heat ...). Its value can be assigned to any of four energy counters. See chapter *Energy*. It can also be used as digital input and included in alarm function to monitor signals from different sensors (see chapter *Alarms*).

Pulse input module has only one hardware configuration (5...48 V DC).

### Digital input module

Module has no settings. General purpose is to collect digital signals from various devices, such as intrusion detection relay, different digital signals in transformer station, industry ... It is available in three different hardware versions. It can also be included in alarm function (see chapter *Alarms*).

### Tariff input module

Module has no setting. It operates by setting active tariff at a tariff input (see chapter *Tariff clock*). The device can have maximal one module with 2 tariff inputs only. With the combination of 2 tariff inputs maximal 4 tariffs can be selected.

Active tariff selection table:

Active tariff	Signal presence on tariff input	
	Input T1	Input T2
Tariff 1	0	0
Tariff 2	1	0
Tariff 3	0	1
Tariff 4	1	1

### Analogue output module

Analogue output module is useful for control and measurement visualization purposes. It can be connected to analogue meters, PLC controllers... It has defined output range 20mA DC. Quantity and shape (up to 6 break points) of an analogue output can be assigned by QDSP2.1 software.

## Output parameter

Output parameter can be any measured value that is required for monitoring, recording, visualization or control. Value is chosen from a drop-down menu.

## Output signal

Output signal can be adjusted to meet all required purposes.

- Shape of output signal (linear, Quadratic)
- Number of break points for zoom function (up to 6)
- Start and End output value

For better visualization of set output signal parameters, graphical presentation of transfer function is displayed.

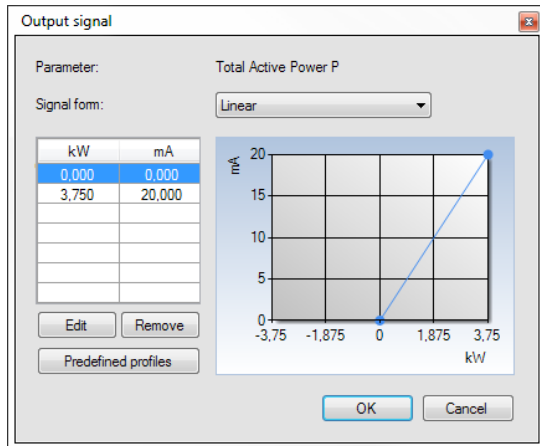

## Pulse output module

Pulse output is a solid state, opto-coupler open collector switch. Its main purpose is pulse output for selected energy counter, but can also be used as an alarm or general purpose digital output.

## Calculation of recommended pulse parameters

Number of pulses per energy unit should be in certain limits according to expected power. Otherwise the measurement from pulse output can be incorrect. Settings of current and voltage transformer ratios can help in estimation of expected power.

Principle described below for pulse setting satisfies EN 62053–31: 2001 standards pulse specifications:

1,5...15 eW → 100 p/1 eWh

e ... exponent (k, M, G)

p ... pulses

Examples:

Expected power	→	Pulse output settings
150 – 1500 kW	→	1 p / 1kWh
1,5 – 15 MW	→	100 p / 1MWh
15 – 150 MW	→	10 p / 1MWh
150 – 1500 MW	→	1 p / 1MWh

## Bistable alarm output module

A Bistable alarm module is a relay type. The only difference between relay alarm output and bistable relay alarm output is that it keeps the condition at output in case of device power failure.

## Alarm Output

If Digital output is defined as an Alarm output, its activity (trigger) is connected to Alarm groups. Multiple alarm groups can be attached to it and different signal shapes can be defined. For more information on how to define alarm groups, see chapter Alarms.

Two parameters should be defined for each alarm output:

- The source for assigned alarm (alarm group 1, 2 or both)
- Type of output signal, when alarm is detected.

## Output signal types

*Normal* – A relay is closed as long as condition for the alarm is fulfilled.

*Normal inverse* – A relay is open as long as condition for the alarm is fulfilled. After that relay goes to closed state

*Latched* – A relay is closed when condition for the alarm is fulfilled, and remains closed until it is manually reset.

*Latched inverse* – A relay is open when condition for the alarm is fulfilled, and remains open until it is manually reset.

*Pulsed* – an impulse of the user set length is activated always when condition for the alarm is fulfilled.

*Pulsed inversed* – Normally relay is activated. An impulse of the user set length deactivates it always when condition for the alarm is fulfilled.

*Always switched on / off* (permanent) – A relay is permanently switched on or off irrespective of the condition for the alarm (general purpose digital output functionality).

Check an example in chapter Alarms for graphical demonstration of alarm functionality.

## Status (Watchdog) and Relay output module

Watchdog and relay module is a combination of two functionalities. One output is used for Watchdog functionality, the other acts as a Relay output module.

The purpose of a Watchdog relay is to detect potential malfunction of device or auxiliary power supply failure. This module can be set for normal operation (relay in close position) or for test purposes to open position (manual activation). After test module should be set back to normal operation.

## Auxiliary I/O Modules A & B

ISTAT M365A/M365B is equipped with two auxiliary I/O slots. The biggest difference in functionality between main and auxiliary I/O modules is in response time. Digital inputs and outputs do not have as fast response time as with main I/O modules.

Following auxiliary I/O modules are available:

Module type	Number of modules per slot
Relay output (RO)	8
Digital input (DI)	8

State of the built in input and/or output module can be monitored also via LEDs on the front panel of the device (M365B only).

---

### PLEASE NOTE

---

Relay output (RO) is only available as module A.

---

## Digital Input Module

The Digital Input Module has no settings. It collects digital input signals from various devices, such as (intrusion detection

relay, different digital signals in transformer station, industry ...).

According to input voltage range it is available in three different hardware versions. For detailed technical specifications see

chapter Technical data.

A digital input can also be used to trigger an alarm (see chapter Settings – Alarms).

The state of digital inputs can also be monitored for control purposes with a SCADA system by reading appropriate MODBUS registers.

## Relay Output Module

Relay output module is a relay switch. Its main purpose is to be used as an alarm output.

For the difference to Relay output module of main I/O module 1/2 and 3/4, also a single alarm can be used to trigger each output (when using Relay output module of main I/O module 1/2 or 3/4 only a single or a combination of alarm groups can be used as a trigger for each output).

For additional information regarding alarms, see chapter Settings – Alarms.

## RTC Synchronization Module C

In order to use Module C for synchronization purposes, it has to be defined as a synchronization source. See chapter General Settings - Real time synchronization source.

### CAUTION

RTC synchronization is essential part of Class A instrument. If no proper RTC synchronization is provided device operates as Class S instrument.

ISTAT M365A/M365B supports three types of RTC synchronization:

- GPS time synchronization (via Synchronization module C)
- IRIG-B time synchronization (via Synchronization module C)
- NTP time synchronization (via Ethernet module)

Instructions regarding connection of Synchronization module C can be found in chapter Connection - Connection of Synchronization module C.

### PLEASE NOTE

Serial communication built in Synchronization Module C can, under certain conditions, be used as an independent secondary communication.

## GPS time synchronization

For proper GPS synchronization, two signals are required.

- 1pps with TTL voltage level and
- NMEA 0183 coded serial RS232 communication sentence

GPS interface is designed as 5 pole pluggable terminal (+5V for receiver supply, 1pps input and standard RS232 communication interface). GE Reason RT43x GNSS clocks are recommended to provide accurate time synchronization.

More details on GE Reason products can be found at [www.gegridsolutions.com](http://www.gegridsolutions.com).

### PLEASE NOTE

When connecting GPS to serial RS232 communication interface, please take required communication parameters into consideration. For proposed GPS receiver default communication speed is 4800 b/s.

## IRIG time code B (IRIG-B)

Unmodulated (DC 5V level shift) via the BNC socket and modulated (1 kHz) serial coded format with support for 1pps, day of year, current year and straight seconds of day as described in standard IRIG-200-04.

Supported serial time code formats are IRIG-B007 and IRIG-B127. For technical specifications see chapter Technical data.

### Serial communication (COM2)

If ISTAT M365A/M365B uses RTC synchronization over NTP server (via Ethernet module), IRIG-B or only 1PPS without date synchronization, serial communication port of RTC Synchronization module C is free to be used as a secondary communication port COM2. Either RS232 or RS485 communication can be used. COM1 and COM2 are completely independent and can be used for the same purpose and at the same time.

Module settings define parameters, which are important for the operation in RS485 network or connections with PC via RS232 communication.

---

 **PLEASE NOTE**

If ISTAT M365A/M365B uses GPS RTC synchronization then serial communication port of RTC Synchronization module C cannot be used at the same time.

---

Factory settings for serial communication COM2 are:

MODBUS Address:	#33 (address range is 1 to 247)
Comm. Speed:	4800 (speed range is 2400 to 115200)
Parity:	none
Data bits:	8
Stop bits:	2

---

 **PLEASE NOTE**

By default, addresses of COM1 and COM2 are the same (#33). In this case, change of COM1 address sets COM2 to the same address. When COM1 and COM2 addresses are not equal, change of COM1 address has no influence on COM2 address and change of COM2 address has no influence on COM1 address.

---





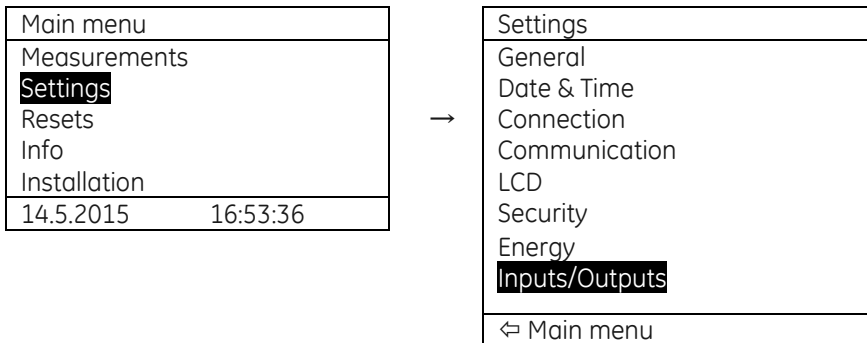

### Settings of RTC Synchronization module C

In order to enable synchronization with GPS or IRIG time code a proper Real Time synchronization source should be defined as described in a chapter General settings/Real Time synchronization source.

## LCD navigation

### M365B



-  Main menu > Settings > Inputs/Outputs > I/O 1
-  Main menu > Settings > Inputs/Outputs > I/O 2
-  Main menu > Settings > Inputs/Outputs > I/O 3
-  Main menu > Settings > Inputs/Outputs > I/O 4
-  Main menu > Settings > Inputs/Outputs > I/O A
-  Main menu > Settings > Inputs/Outputs > I/O B
-  Main menu > Settings > Inputs/Outputs > I/O C

### M365A

Inputs/Outputs for Power Quality Analyzer M365A can only be set in QDSP2.1 software. Using device TFT display, you can check Inputs/Outputs status by navigating to Modules:

Main menu > Measurements > Modules > IO 1...4 / IO A / IO B / IO C

## Alarms

Alarms are used for indicating exceeded set values of measured quantities and quantities from different input modules.

Alarms can also trigger different actions according to their settings:

- Visual (alarms causes special alarm LED to lit-up).  
When alarm is switched on a red LED on the device front side is blinking – only M365B. See figure below. On M365A there is no dedicated LED for alarms (when alarm I present,  icon is displayed in top right corner of TFT display).
- Sound (alarms can cause sound signalization)  
When alarm is switched on, an audible alarm is given by the device (a beep). It can be switched off by pressing any key on the front plate (see figure below).
- Alarm output (alarms can switch digital outputs on main and aux. I/O modules)
- According to the alarm signal shape the output relay will behave as shown on figure below.

Alarm condition can be set for any measured quantity, also for quantities measured on Analogue inputs or signals from Digital / Pulse input.

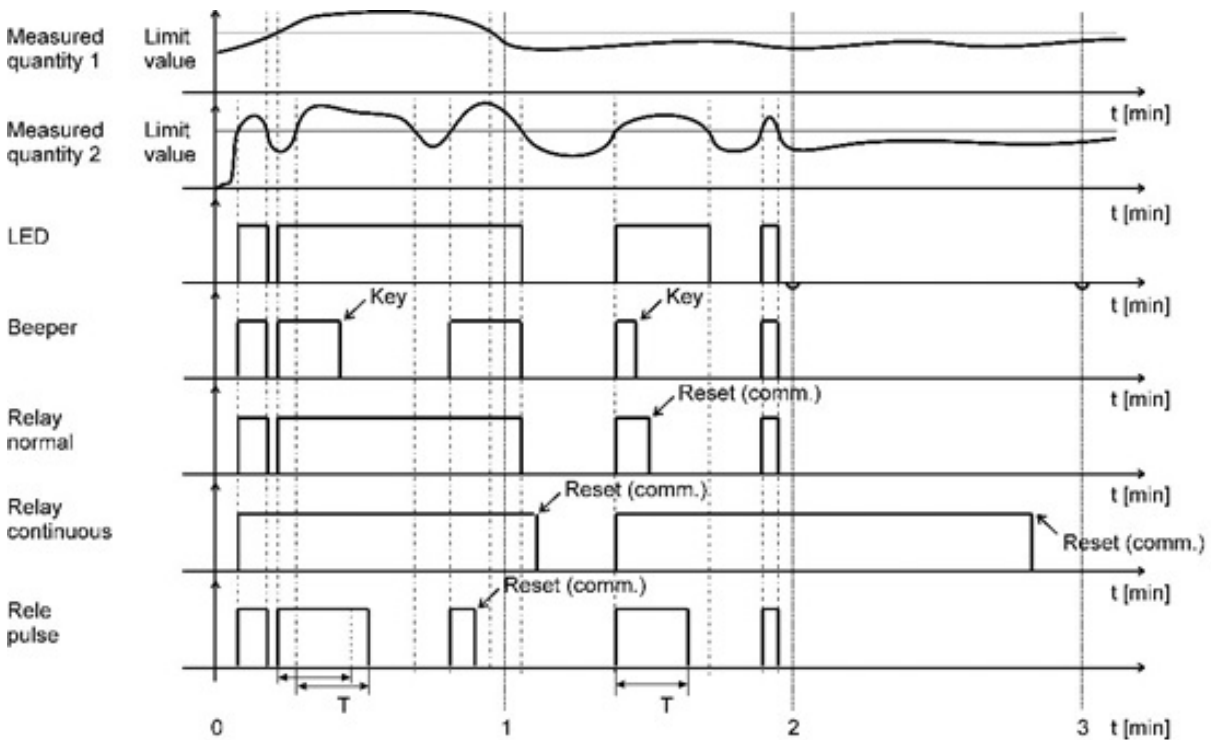

### CAUTION

New values of alarms are calculated in percentage. At every modification of connection settings crosscheck if set alarm values are correct.

## Alarm statistics reset

ISTAT M365A/M365B evident all triggered alarms and stores it in internal RAM. Statistic is valid since last power supply-on and could be reset with QDSP2.1, see chapter Reset operations.

This setting is only for resetting online alarms statistics displayed in QDSP2.1.

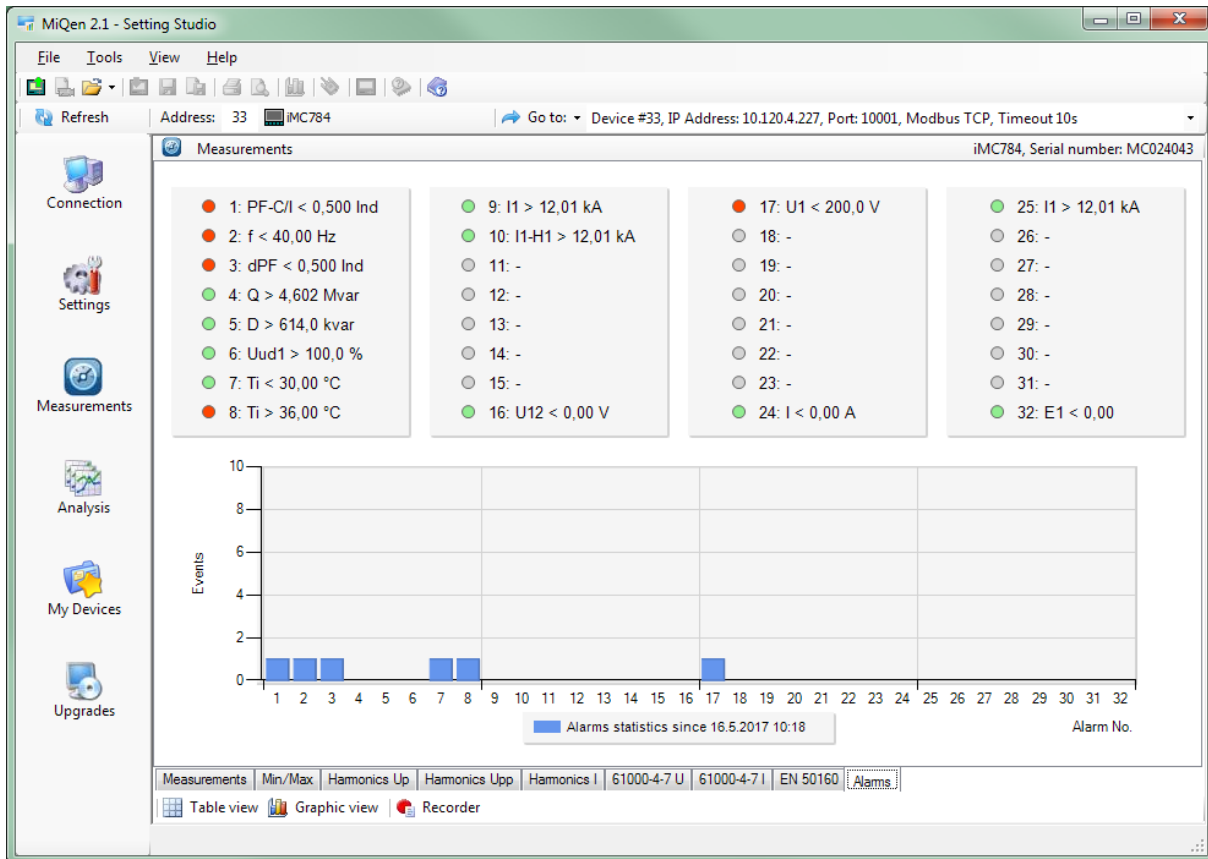

Alarms statistics for showing graphical representation of frequency of alarms occurrence.

## Alarms group settings

ISTAT M365A/M365B supports recording and storing of 32 alarms that are divided into 4 groups of 8 alarms. Each group of alarms has some common settings applicable for all alarms within this group:

### *Maximum Demand (MD) constant (min)*

Sets a thermal mode maximum demands time constant for the alarm group. When monitoring certain quantity it is possible to monitor its actual value or its max. demand value. If latter is chosen then a time constant for calculation of thermal mode max. demand value should be set. This setting is for alarm purposes only and is independent of max. demand calculation settings for monitoring and recording purposes as described in chapter Maximum demand calculation.

### *Compare time delay (sec)*

This setting defines delay time (if required) between satisfying the alarm condition and alarm activation. If alarm condition is shorter then this setting alarm will not be triggered. This setting is used to rule out sporadic and very short duration triggers.

### *Hysteresis (%)*

This setting defines alarm deactivation hysteresis. When monitored quantity is close to set limit line its slight variation can trigger numerous alarms. Hysteresis should be set according to estimated variation of monitored quantity.

### *Response time*

This setting defines alarm response on monitored quantity.

*Normal response:* In this case monitored quantity is averaged according to display averaging settings (0.1 to 5s – see chapter General settings / Average interval).

*Fast response:* In this case alarms react on non-averaged measurements (1 signal period). This setting should be used according to required functionality. Fast response is more prone to glitches and transient effects in a system but reaction time is fast.

### *Individual alarm settings*

For each individual alarm different settings are possible.

*Individual Alarms settings*

**Parameter**

This setting defines a quantity that will be monitored. It is also possible to select process quantities from I/O modules.

**Value**

For chosen monitoring parameter an actual value or MD value should be set.

**Condition**

It is a combination of a logical operator "Higher than" or "Lower than" and a limit value of the condition. For digital / pulse input it is possible to set condition is "Is high" or "Is low".

**Action**

This section is consists of checkboxes that applies different functions to individual alarms.

Switch on Relay checkbox can be selected if user wants this alarm to trigger output(s) that are connected to its group of alarms (pulse, relay or bistable output module). When using relay outputs of I/O module A or B also a single alarm can be used as a trigger. In this case Switch on Relay setting has no influence.

Switch on sound signal checkbox will activate built in beeper when alarm is active.

Alarm enabled checkbox, activates alarm.

## Advanced recorders

ISTAT M365A/M365B enables recording of wide variety of data in the internal 8GB flash memory.

All trigger related recorder data is available on-demand through FTP.

All parameters can be defined in the Settings menu (directly through LCD screen on M365B) or in QDSP2.1 (PC Software).

Following parameters can be defined:



- Data presentation time:  
Select time for recorded data time stamps. Store data in UTC or local time.
- Filled memory mode:  
Define behavior of recorder when internal memory is full. "Overwrite all records" is a standard FIFO functionality. If it is important not to overwrite any old records "Stop recording" should be used.

## Logical Inputs and Logical Functions

In electronics, a logic gate is an idealized or physical device implementing a Boolean function; it performs a logical operation on one or more logical inputs, and produces a single logical output. Boolean functions may be practically implemented by using electronic gates. The following points are important to understand:

- Electronic gates require a power supply.
- Gate INPUTS are driven by voltages having two nominal values, e.g. 0V and 5V representing logic 0 and logic 1 respectively.
- The OUTPUT of a gate provides two nominal values of voltage only, e.g. 0V and 5V representing logic 0 and logic 1 respectively. In general, there is only one output to a logic gate except in some special cases.
- There is always a time delay between an input being applied and the output responding.

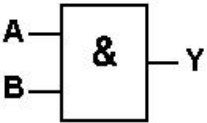
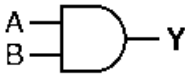
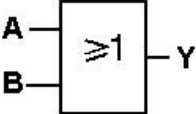
Basic logical functions are: AND, OR, XOR, NOT, NAND, NOR and XNOR. M365 Advanced Power Quality Analyzer supports AND/OR logical functions. The effect of AND/OR functions are described in the table below. For each of the logic functions European symbol (IEC) and the American symbol (for practical reasons) are drawn. Logical Inputs are labelled with tags A and B. Truth table shows the function of a logic gate.

Name	IEC symbol	American symbol	Description	Truth table																		
AND			<p>A HIGH output (1) results only if both the inputs to the AND gate are HIGH (1). If neither or only one input to the AND gate is HIGH, a LOW output results. In another sense, the function of AND effectively finds the minimum between two binary digits. Therefore, the output is always 0 except when all the inputs are 1.</p>	<table border="1"> <thead> <tr> <th colspan="2">Input</th> <th>Output</th> </tr> <tr> <th>A</th> <th>B</th> <th>A AND B</th> </tr> </thead> <tbody> <tr> <td>0</td> <td>0</td> <td>0</td> </tr> <tr> <td>0</td> <td>1</td> <td>0</td> </tr> <tr> <td>1</td> <td>0</td> <td>0</td> </tr> <tr> <td>1</td> <td>1</td> <td>1</td> </tr> </tbody> </table>	Input		Output	A	B	A AND B	0	0	0	0	1	0	1	0	0	1	1	1
Input		Output																				
A	B	A AND B																				
0	0	0																				
0	1	0																				
1	0	0																				
1	1	1																				
OR			<p>A HIGH output (1) results if one or both the inputs to the gate are HIGH (1). If neither input is high, a LOW output (0) results. In another sense, the function of OR effectively finds the maximum between two binary digits.</p>	<table border="1"> <thead> <tr> <th colspan="2">Input</th> <th>Output</th> </tr> <tr> <th>A</th> <th>B</th> <th>A OR B</th> </tr> </thead> <tbody> <tr> <td>0</td> <td>0</td> <td>0</td> </tr> <tr> <td>0</td> <td>1</td> <td>1</td> </tr> <tr> <td>1</td> <td>0</td> <td>1</td> </tr> <tr> <td>1</td> <td>1</td> <td>1</td> </tr> </tbody> </table>	Input		Output	A	B	A OR B	0	0	0	0	1	1	1	0	1	1	1	1
Input		Output																				
A	B	A OR B																				
0	0	0																				
0	1	1																				
1	0	1																				
1	1	1																				

Following parameters can be defined:

- Logical input 1-16:  
Select which Digital input (depends on installed I/O modules) is connected to which Logical input. Also select which state is defined as active level (High or Low). Logical inputs are used for defining digital and combined triggers.
- Logical function 1-16:  
Select logical function over existing logical inputs and alarms to create conditional triggering functions. Logical functions can also be nested (result of one logical function can be used as an input for a logical operation of another) to achieve multiple-conditioned triggers.

Logical inputs – each of logical inputs can be defined with digital input (Input module has to be installed). Active value can be set on HIGH or LOW:

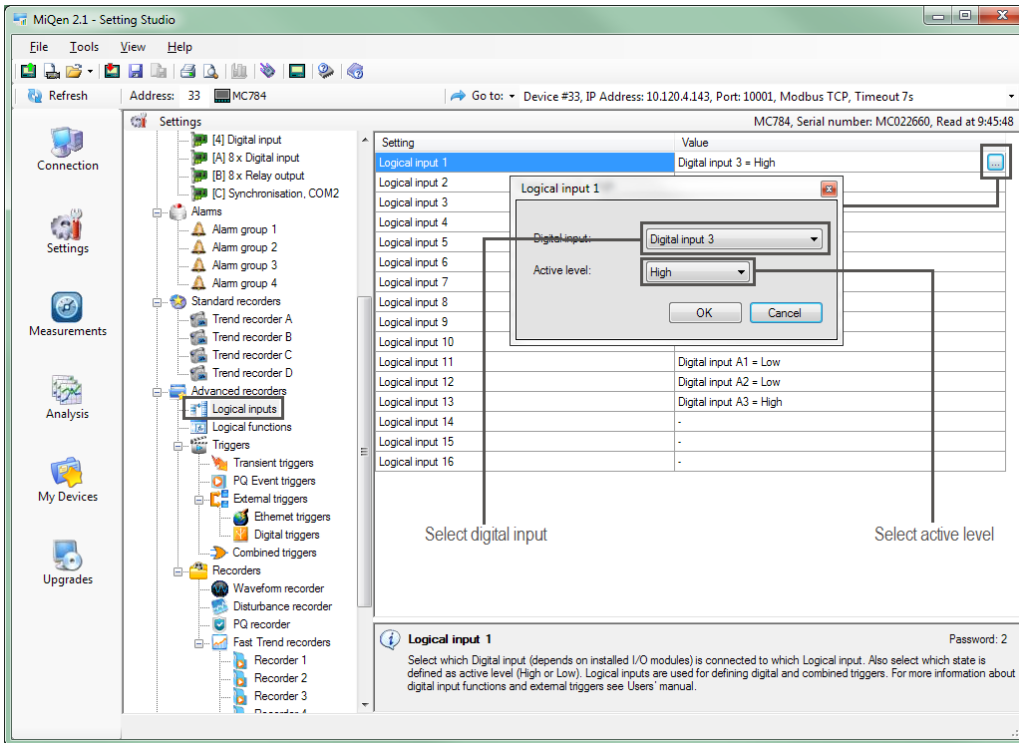

Defining Logical inputs parameters (QDSP2.1): Settings – Advanced recorders – Advance recorders – Logical inputs.

Logical function - Select logical function over existing logical inputs and alarms:

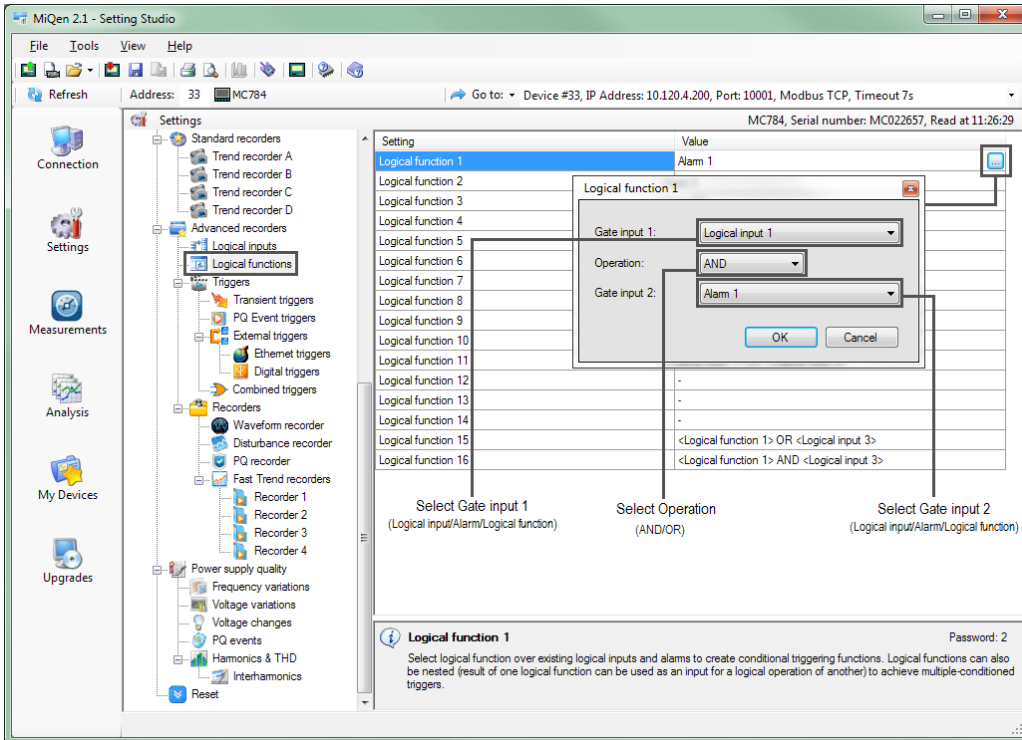

Defining Logical functions parameters (QDSP2.1): Settings – Advanced recorders – Advance recorders – Logical functions.

## Triggers

A challenge for a Power Quality Analyzer is to record relevant data, however it is difficult for an analyzer to determine which data events are important.

Recording data with 50Hz waveform resolution would capture significant data but much of the information may not be relevant. To avoid such scenarios and efficiently record data, triggers are used. If trigger thresholds are set correctly, only important data will be recorded.

A sophisticated triggering mechanism is used to register and record events in various ways:

- Transient triggers
- PQ event triggers
- External Ethernet
- External digital triggers
- Combined triggers

### *Transient triggers*

Transient is an analog signal which can reach high magnitudes in a very short duration of time. Power system transients can be caused by lightning, switching actions and faults in the power system. Signal can reach high magnitudes and depending on rise time, peak value, wave shape and frequency of occurrence the impact on power system components and end user equipment can be severe. The damages can be operational problems, accelerated ageing and immediate damage to equipment. By setting up a trigger you can start acquiring the signal once the trigger condition is satisfied.

There are two independent criteria by which transients are recognized:

- Absolute Peak value (%) – If a sampled value exceeds the set threshold, a transient is recognized.
- Fast change (%Un/ $\mu$ s) – If the difference between two neighboring sampled points exceeds the set threshold, a transient is recognized.

After transient has been recognized it can trigger Waveform /Disturbance recorder or/and it can send Ethernet trigger to other connected devices within network.

### **Absolute Peak Value (%)**

In general transients are divided into two categories which are easy to identify: impulsive and oscillatory. If the mains signal is removed, the remaining waveform is the pure component of the transient. The transient is classified in the impulsive category when 77% of the peak-to-peak voltage of the pure component is of one polarity. Absolute peak value transient detection is used to detect transient of impulsive type.

Threshold is set in percentage of absolute peak value. If a sampled value exceeds the set threshold, a transient is recognized. To disable Absolute Peak Value detection choose "Disabled" in transient trigger menu.

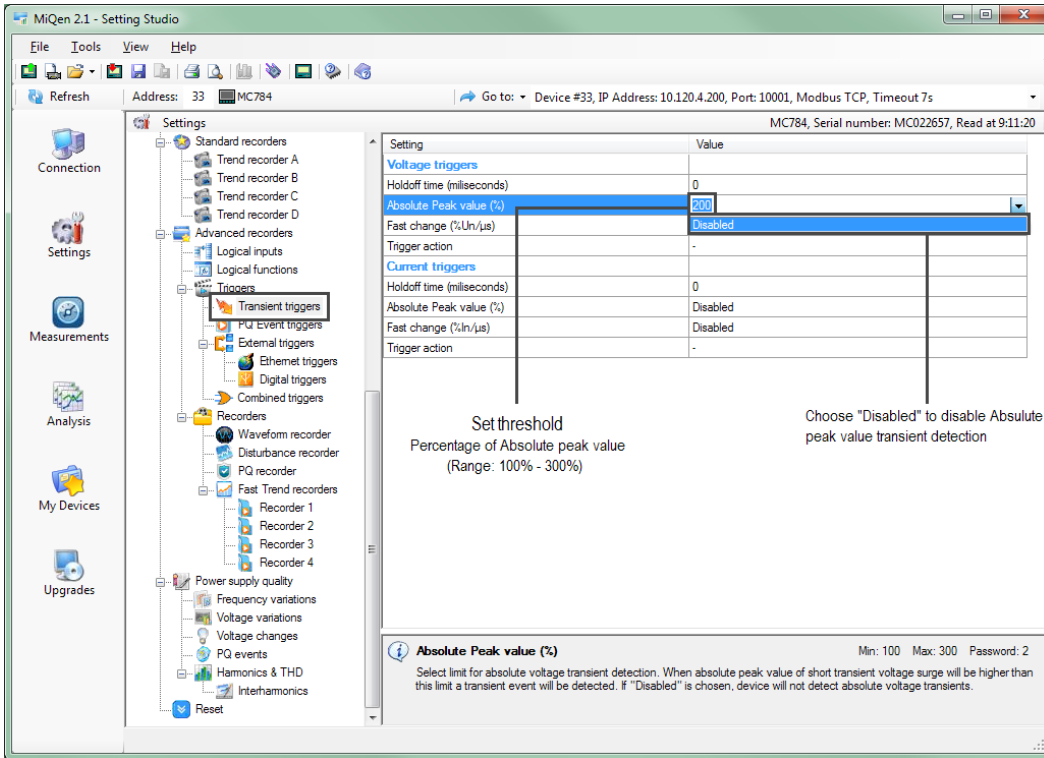

Defining Absolute peak value transient parameters (QDSP2.1): Settings – Advanced recorders – Triggers – Transient triggers

Example:

In system with voltage range of 250V RMS and current range of 5A RMS, 100% Absolute peak value for:

- phase voltage is 353.55V,
- interphase voltage is 612.37V and
- current is 7,071A

If threshold is set to 200% of Absolute peak value, transient will be detected when absolute peak value of phase voltage rises above 707.1V (See picture - *Transient value exceeds Absolute peak value threshold*).

Same principal applies to current transient triggers.

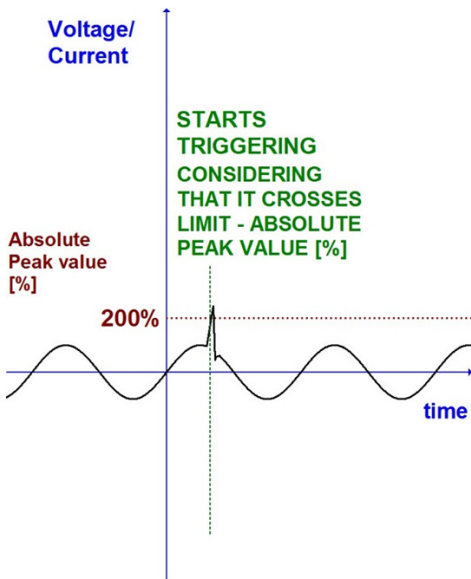

Transient value exceeds Absolute peak value threshold (%)

## Fast change (%Un/ $\mu$ s)

Fast change transient detection is used to detect transient of oscillatory type. In order to detect transients of oscillatory type, two neighboring sampled points are compared. If a value deviation between these two sampled points exceeds predefined threshold, a transient is recognized.

Threshold is set in percentage of nominal value from 1%/ $\mu$ s to 10%/ $\mu$ s, where 10%/ $\mu$ s represents 320%/32 $\mu$ s (because of the maximum sampling time of 32  $\mu$ s). To disable Fast change detection choose "Disabled" in transient trigger menu.

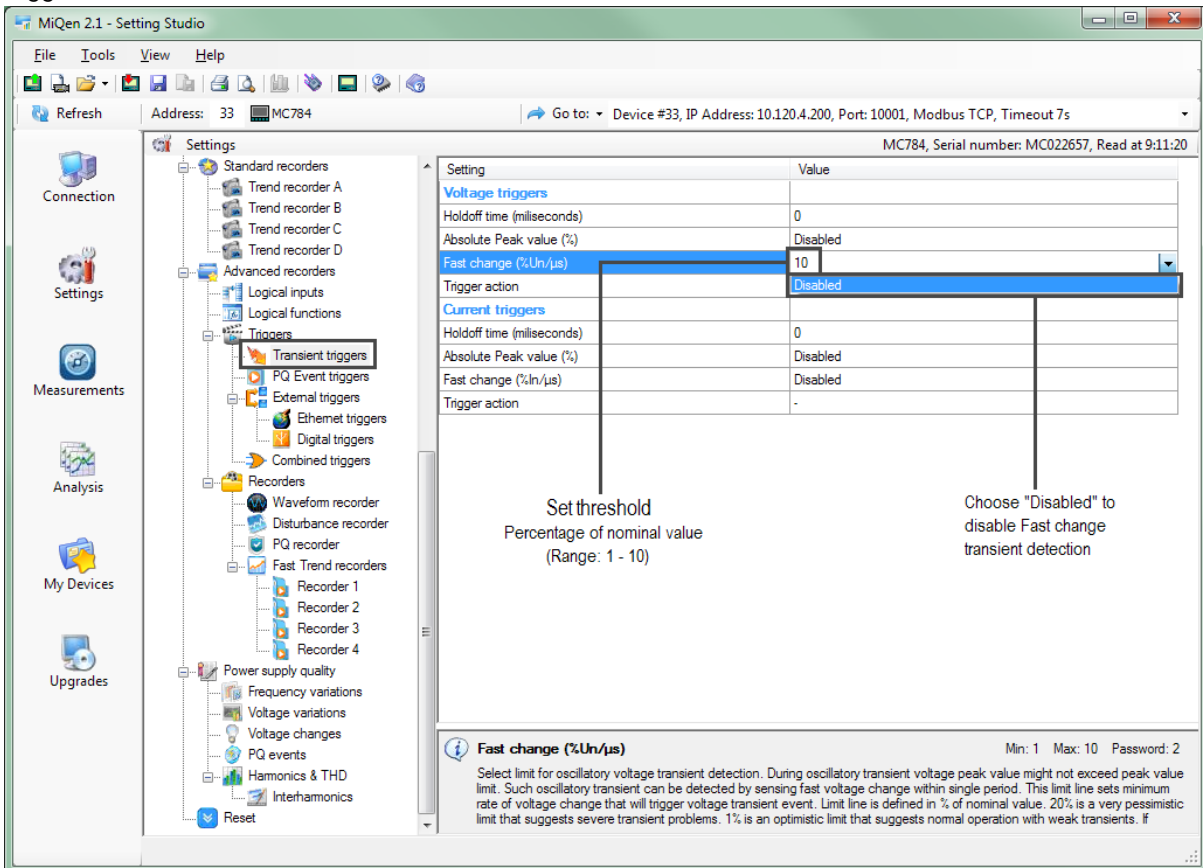

Defining Fast change transient parameters (QDSP2.1): Settings – Advanced recorders – Triggers – Transient triggers

Example:

Value of 10 is set as threshold for fast change transient detection, which represents 320%/32 $\mu$ s. Transient will be detected when current sample point value – Un2 is 320% higher/lower than the previous one – Un1 (samples are 32 $\mu$ s apart) – see picture: *Transient value exceeds Fast change value threshold.*

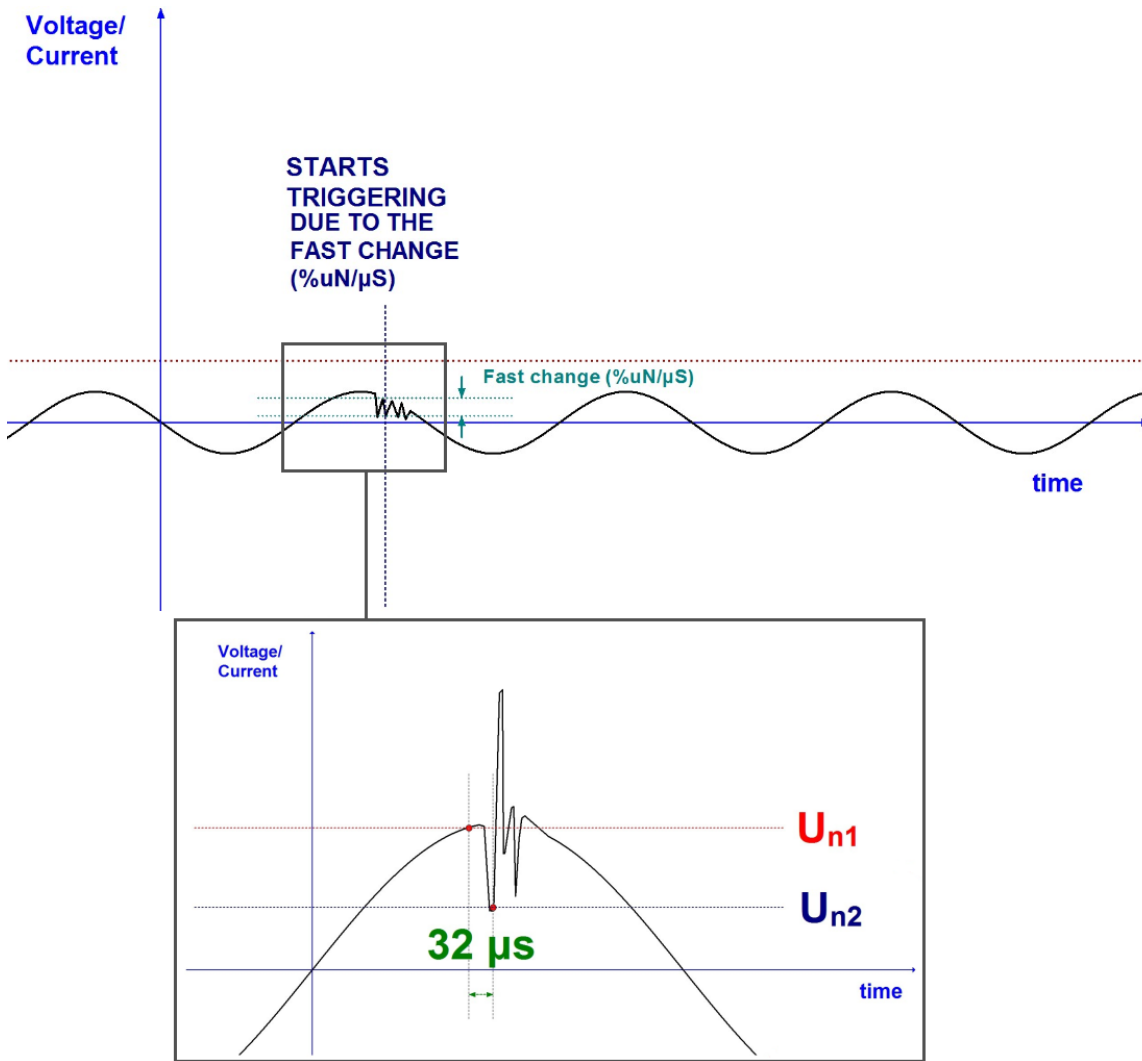

Transient value exceeds Fast change value threshold

Same principal applies to current transient triggers.

## Holdoff time

Predefined Holdoff time starts when transient is detected, during this time no additional transient is detected. Setting is used to avoid false detection of multiple transients as a consequence of the common source.

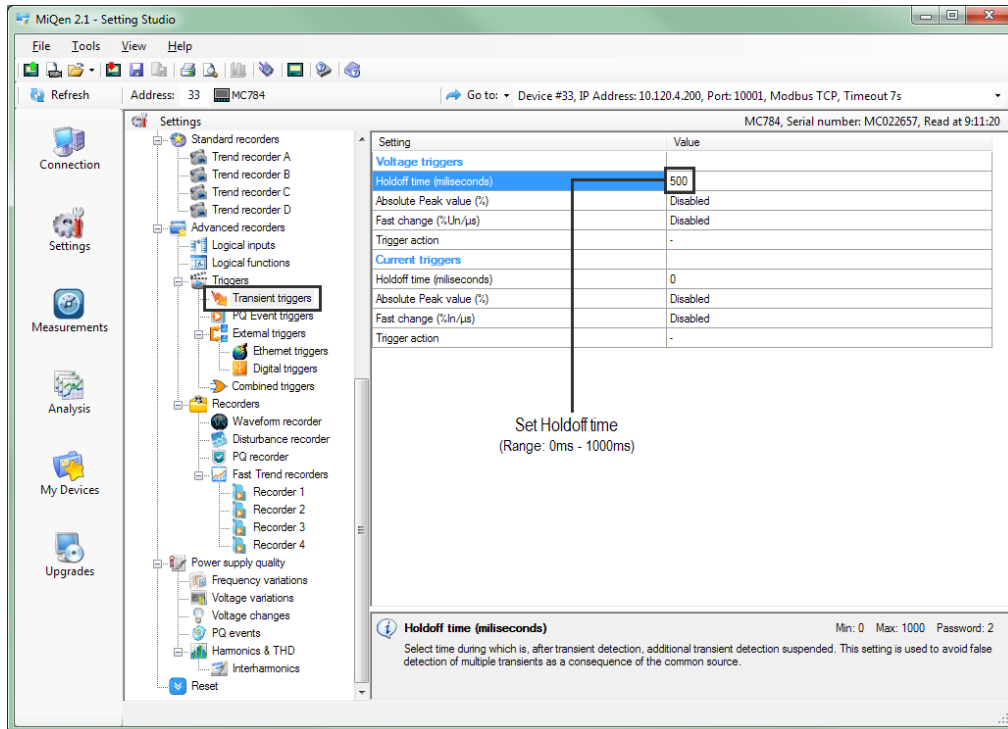

Defining Holdoff time (QDSP2.1): Settings – Advanced recorders – Triggers – Transient triggers

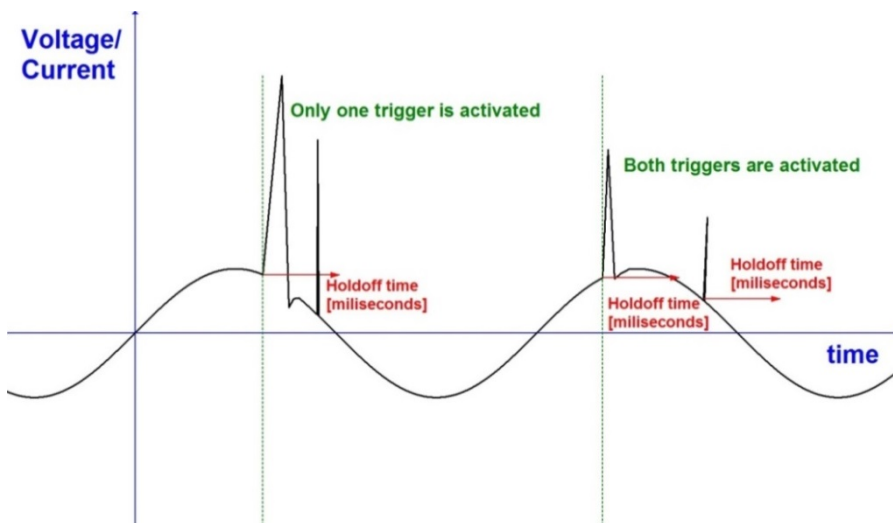

Transient trigger to Holdoff time relationship

On the first period there are two impulsive type transients, but only one trigger was activated since both transients are within Holdoff time. In this case we have avoided false detection of multiple transients since both transients are likely consequence of the common source.

On the second period there are again two impulsive type transients, but now, one of them starts just after Holdoff time ends. In this case two triggers are activated.

### **PLEASE NOTE**

Within one period (20ms for 50Hz) only one transient will be recorded even though Holdoff time is set to 0.

Same principal applies to current transient triggers.

## Trigger action

Trigger action gives you option to choose what happens when transient is detected. There are three options available (Actions):

- Waveform recording (transient detection triggers Waveform recording)
- Disturbance recording (transient detection triggers Disturbance recording)
- Send Ethernet trigger (transient detection triggers Send Ethernet trigger)

All three options can be triggered at the same time.

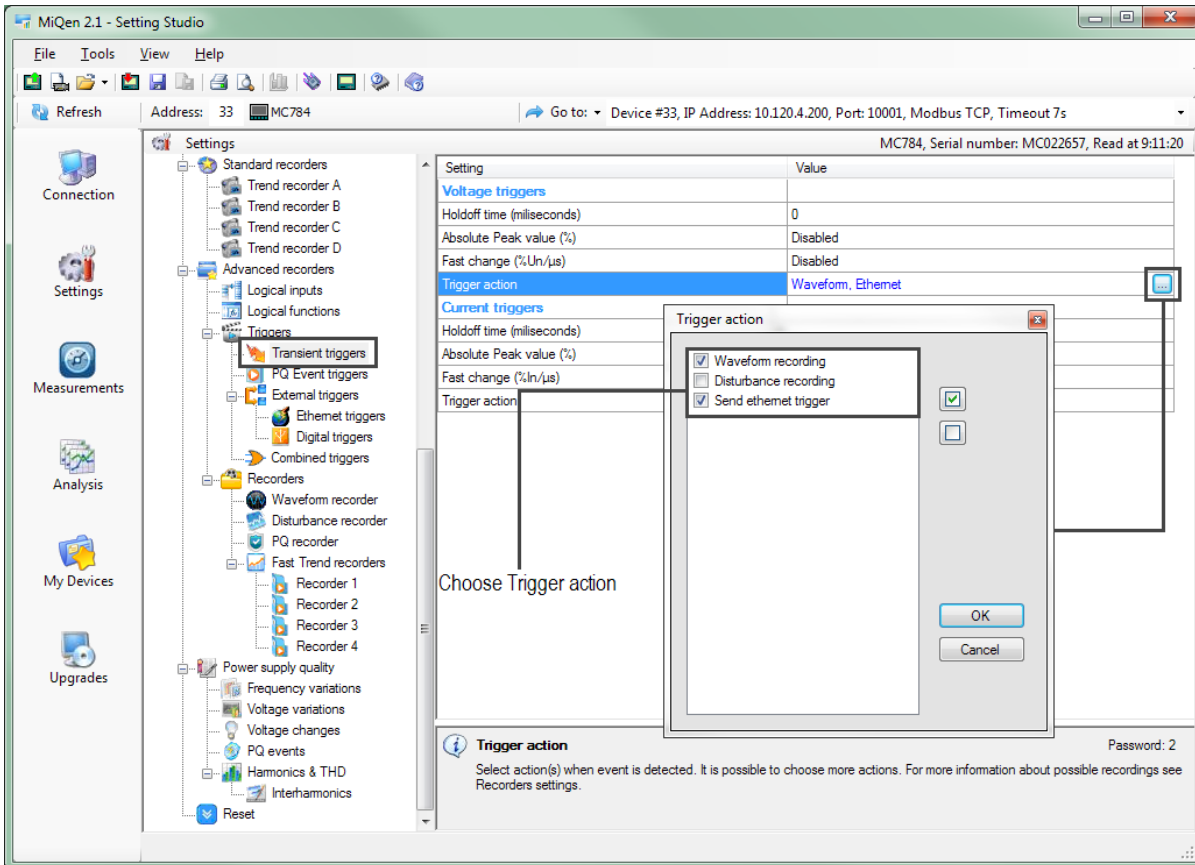

Defining Trigger action (QDSP2.1): Settings – Advanced recorders – Triggers – Transient triggers

Same principal applies to current transient triggers.

### PQ Event triggers

PQ event generated triggers based on the following events:

- **Voltage Dip**

A decrease of the normal voltage level between 10 and 90% of the nominal RMS voltage for durations of 0,5 cycle to 1 minute.

Voltage dips are usually caused by faults on the transmission or distribution network (most of the times on parallel feeders), faults in consumer's installation, connection of heavy loads and start-up of large motors.

ISTAT M365A/M365B with its Voltage dip trigger is capable of detecting and recording voltage dip events. Later analysis of gathered data can help us determine the cause of event. Knowing the cause, appropriate measures can be taken to prevent similar faults in the future.

This is important since voltage dip can result in malfunction of information technology equipment, namely microprocessor-based control systems (PCs, PLCs, ASDs,...) that may lead to a process stoppage, tripping of contactors and electromechanical relays, disconnection and loss of efficiency in electric rotating machines.

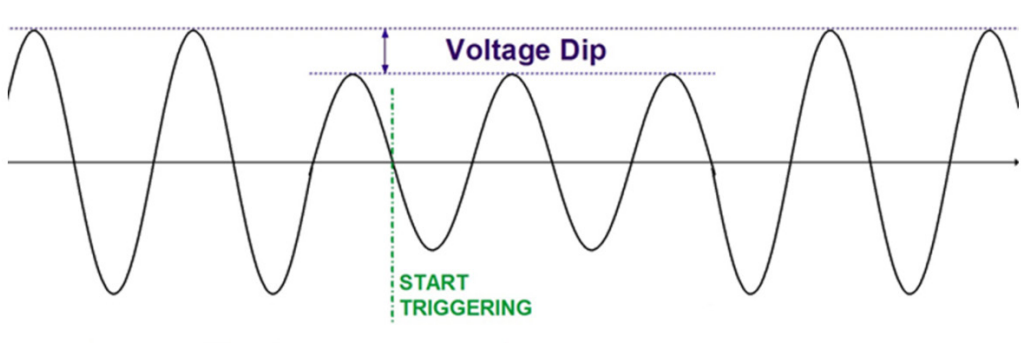

Voltage dip

Voltage dip action:

- Waveform recording (detection of voltage dip triggers Waveform recording)
- Disturbance recording (detection of voltage dip triggers Disturbance recording)
- Send Ethernet trigger (detection of voltage dip triggers Send Ethernet trigger)

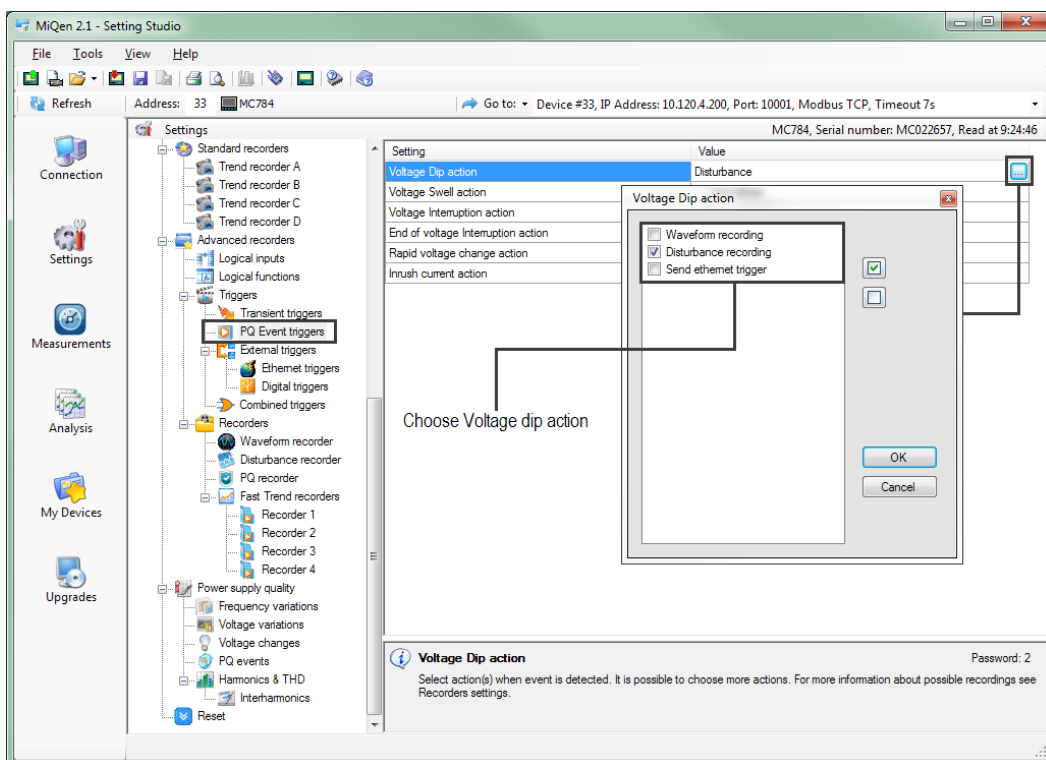

Defining Voltage dip action (QDSP2.1): Settings – Advanced recorders – Triggers – PQ Event triggers

All three options can be triggered at the same time.

### • Voltage Swell

Momentary increase of the voltage, outside the normal tolerances (over 110% of the nominal RMS voltage), with duration of more than one cycle and typically less than a few seconds.

Voltage swells are usually caused by start/stop of heavy loads, badly dimensioned power sources, badly regulated transformers (mainly during off-peak hours) and a single-phase fault on a three-phase system.

ISTAT M365A/M365B with its Voltage swell trigger is capable of detecting and recording voltage swell events. Later analysis of gathered data can help us determine the cause of event. Knowing the cause, appropriate measures can be taken to prevent similar faults in the future.

This is important since voltage swell can result in data loss, flickering of lighting and screens, stoppage or damage of sensitive equipment (semiconductors), insulation degradation,...

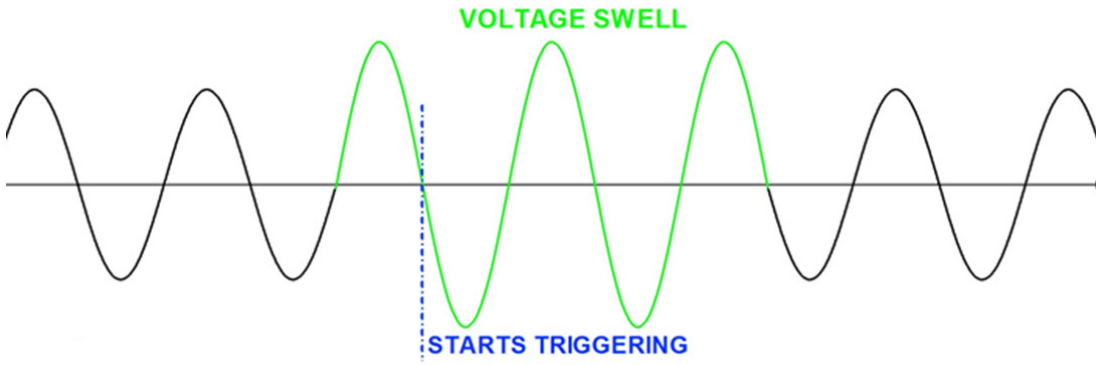

Voltage swell

Voltage swell action:

- Waveform recording (detection of voltage swell triggers Waveform recording)
- Disturbance recording (detection of voltage swell triggers Disturbance recording)
- Send Ethernet trigger (detection of voltage swell triggers Send Ethernet trigger)

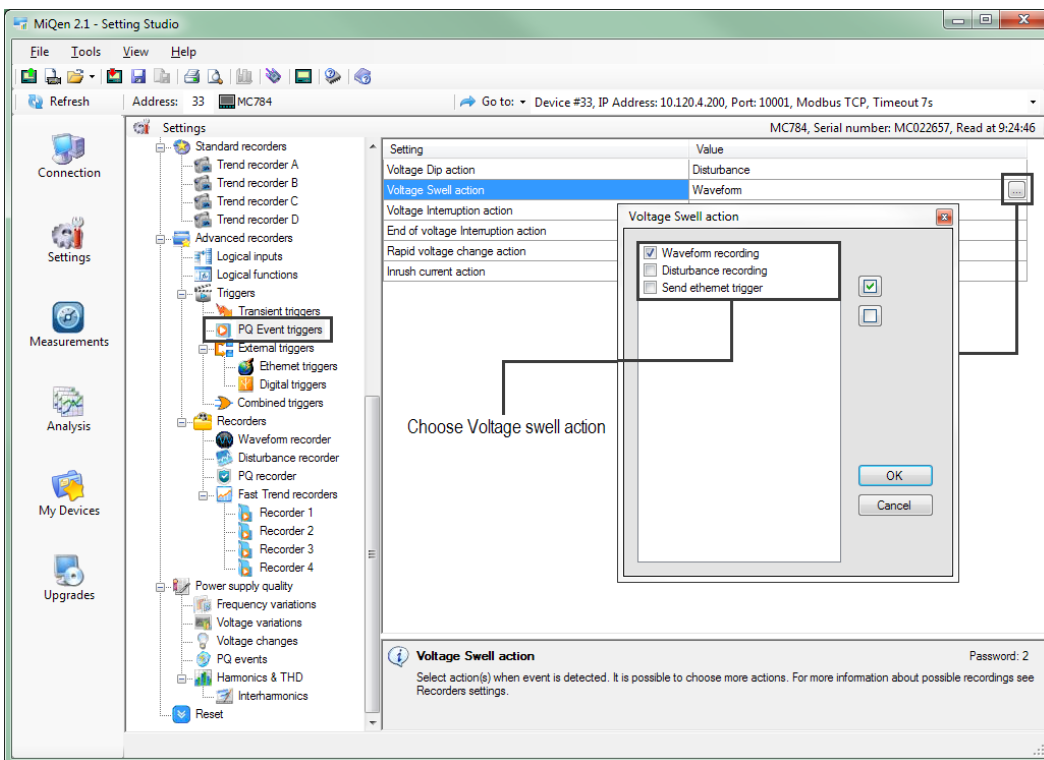

Defining Voltage swell action (QDSP2.1): Settings – Advanced recorders – Triggers – PQ Event triggers

All three options can be triggered at the same time.

• **Voltage Interruption**

There are two types of voltage interruptions:

- Short interruptions (reduction in line-voltage to less than 5% of nominal voltage for duration of up to 3 minutes - 70% of Short interruptions < 1 s; According to EN 50160)
- Long interruptions (reduction in line-voltage to less than 5% of nominal voltage for duration greater than 3 minutes; According to EN 50160)

Both short and long interruptions are detected by ISTAT M365A/M365B. In some cases when predefined recorder post-trigger time is shorter than interruption duration time, only start of interruption will be recorded. In cases like that End of voltage interruption trigger can be predefined so that end of voltage interruption is detected and recorded.

Short interruptions are usually caused by opening and automatic re-closure of protection devices to decommission a faulty section of the network. The main fault causes are insulation failure, lightning and insulator flashover.

Long interruptions are usually caused by Equipment failure in the power system network, storms and objects (trees, cars, etc.) striking lines or poles, fire, human error, bad coordination or failure of protection devices.

ISTAT M365A/M365B with its Voltage interruption trigger is capable of detecting and recording voltage interruption events. Later analysis of gathered data can help us determine the cause of event. Knowing the cause, appropriate measures can be taken to prevent similar faults in the future.

This is important since voltage interruption can result in Tripping of protection devices, loss of information and malfunction of data processing equipment, stoppage of sensitive equipment, such as ASDs, PCs, PLCs; Stoppage of all equipment.

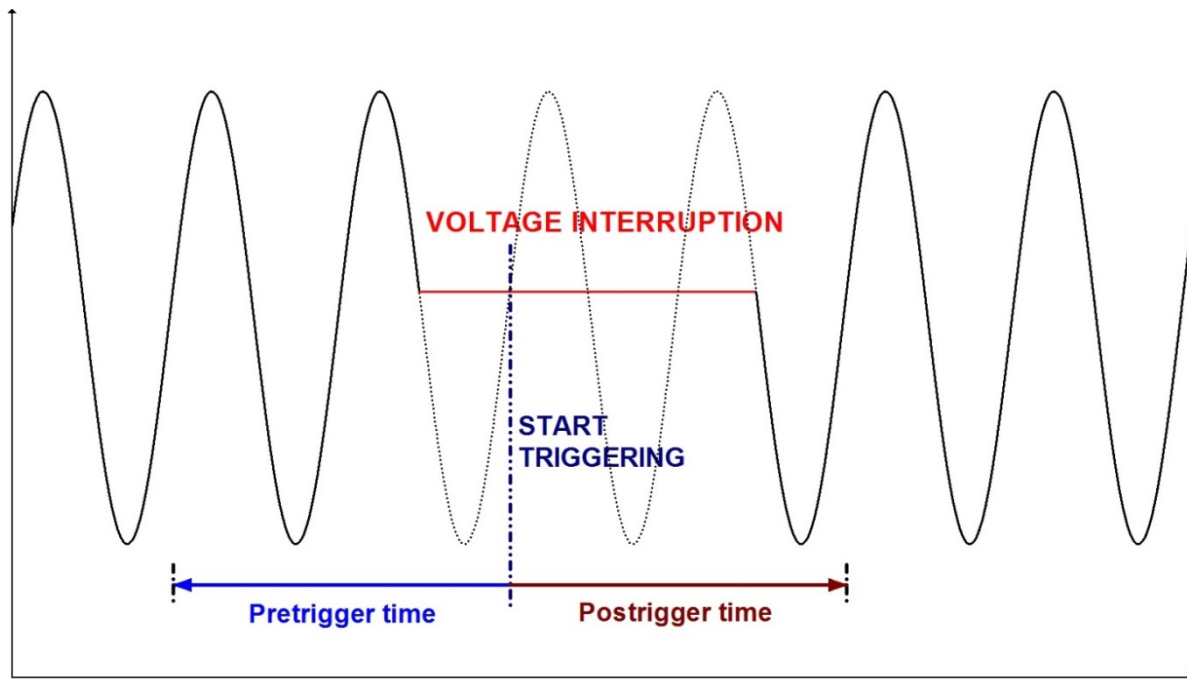

Voltage interruption

Voltage interruption action:

- Waveform recording (voltage interruption triggers Waveform recording)
- Disturbance recording (voltage interruption triggers Disturbance recording)
- Send Ethernet trigger (voltage interruption triggers Send Ethernet trigger)

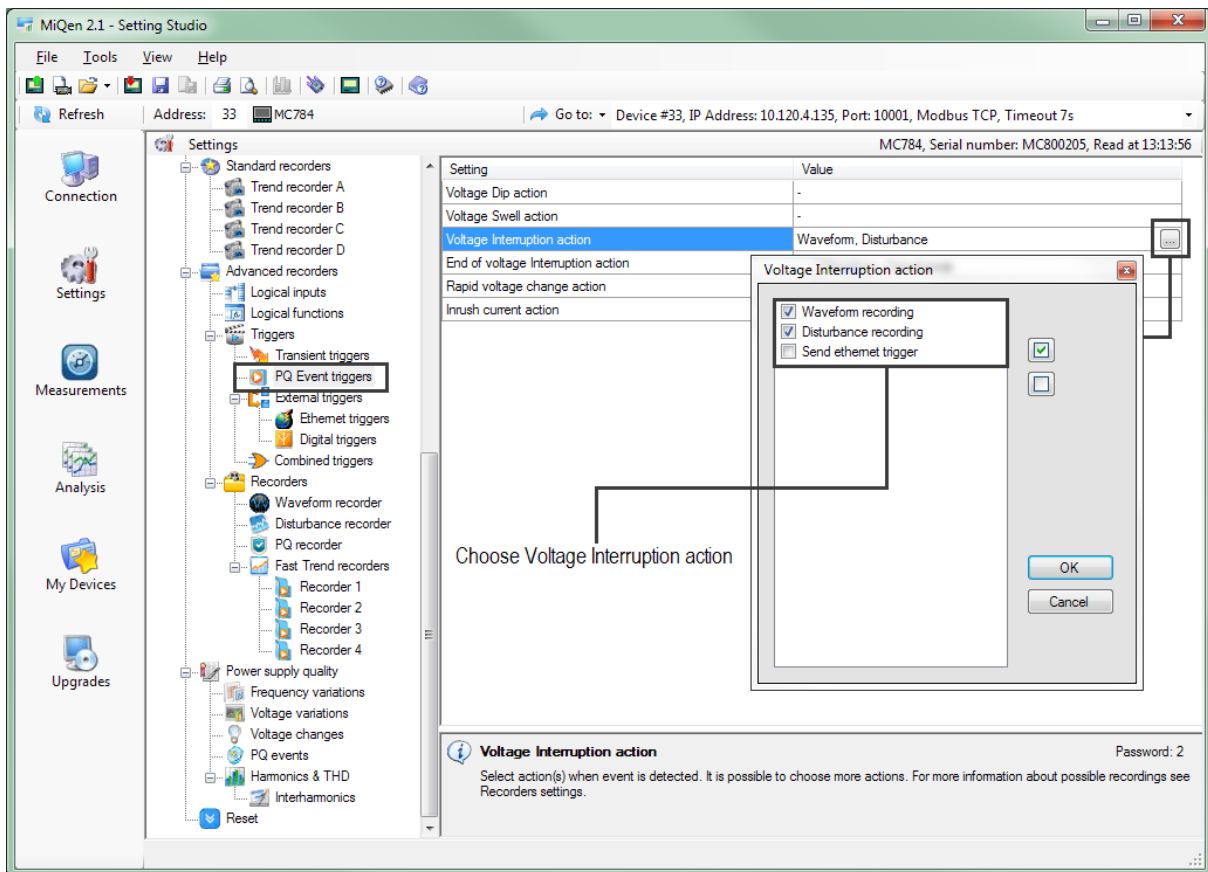

Defining Voltage interruption action (QDSP2.1): Settings – Advanced recorders – Triggers – PQ Event triggers

All three options can be chosen simultaneously.

- **End Of Voltage Interruption**

In some cases when predefined recorder post-trigger time is shorter than interruption duration time, only start of interruption will be recorded. In cases like that End of voltage interruption trigger can be predefined so that end of voltage interruption is detected and recorded.

End of voltage interruption is detected when voltage rises above 7% of the nominal voltage. 5% is voltage interruption upper limit + 2% predefined hysteresis. Hysteresis is required to avoid multiple triggers following the same event.

End of voltage interruption action:

- Waveform recording (end of voltage interruption triggers Waveform recording)
- Disturbance recording (end of voltage interruption triggers Disturbance recording)
- Send Ethernet trigger (end of voltage interruption triggers Send Ethernet trigger)

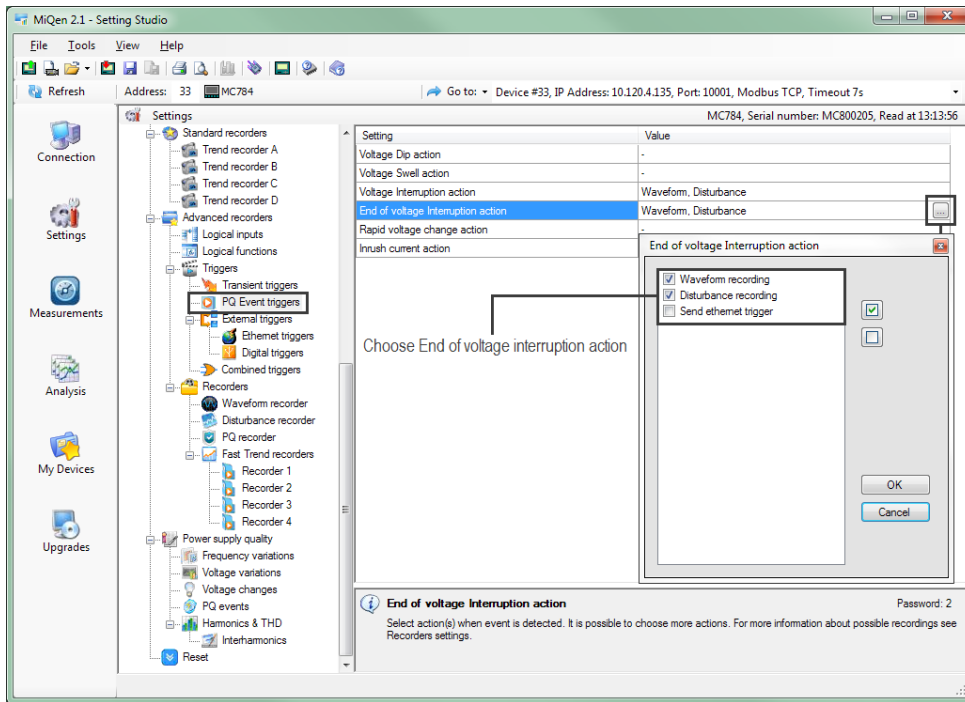

Defining End of voltage interruption action (QDSP2.1): Settings – Advanced recorders – Triggers – PQ Event triggers

All three options can be triggered at the same time.

#### • Rapid Voltage Change

A rapid voltage change is a transition in RMS voltage between two steady-state conditions. Every time a new half-cycle  $U_{rms}$  value is available, the arithmetic mean of the previous 100(50Hz)/120(60Hz) half-cycle  $U_{rms}$  values, including the new value, is calculated. If every one of the previous half-cycle 100/120  $U_{rms}$  values, including the new value, is within the RVC threshold (including the hysteresis, if applied) of the arithmetic mean, then no RVC is detected. If one of the values exceeds RVC threshold (including the hysteresis, if applied) then RVC is detected. If voltage value exceeds dip or swell thresholds is no longer consider as Rapid voltage change but as dip or swell.

An RVC event is characterized by four parameters: start time, duration,  $\Delta U_{max}$  and  $\Delta U_{steady-state}$ :

- $\Delta U_{max}$  is the maximum absolute difference between any of the half-cycle  $U_{rms}$  values during the RVC event and the final arithmetic mean 100/120 half-cycle  $U_{rms}$  value just prior to the RVC event.
- $\Delta U_{ss}$  is the absolute difference between the final arithmetic mean 100/120 half-cycle  $U_{rms}$  value just prior to the RVC event and the first arithmetic mean 100/120 half-cycle  $U_{rms}$  value after the RVC event.

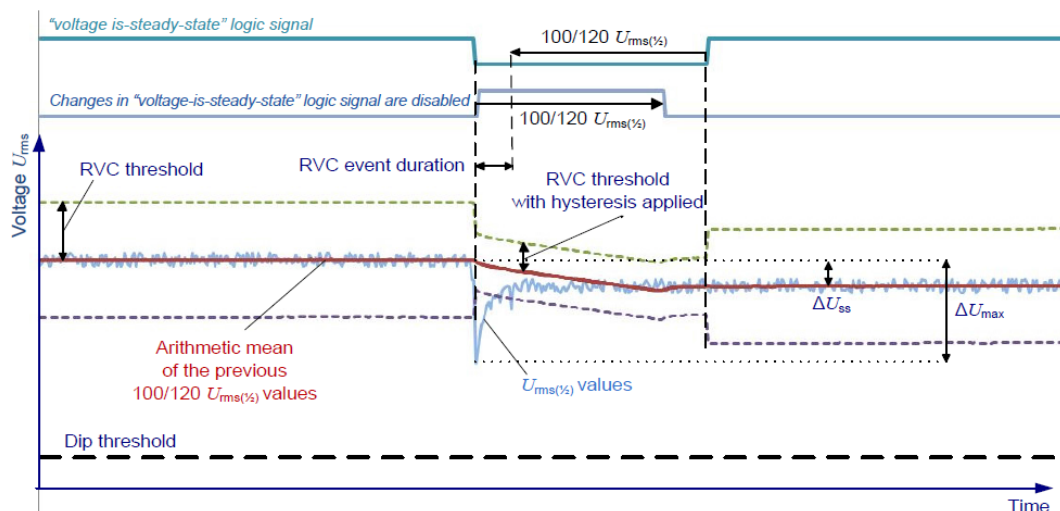

Rapid voltage change (source – IEC6100-4-30 standard)

Rapid voltage change action:

- Waveform recording (detection of Rapid voltage change triggers Waveform recording)
- Disturbance recording (detection of Rapid voltage change triggers Disturbance recording)
- Send Ethernet trigger (detection of Rapid voltage change triggers Send Ethernet trigger)

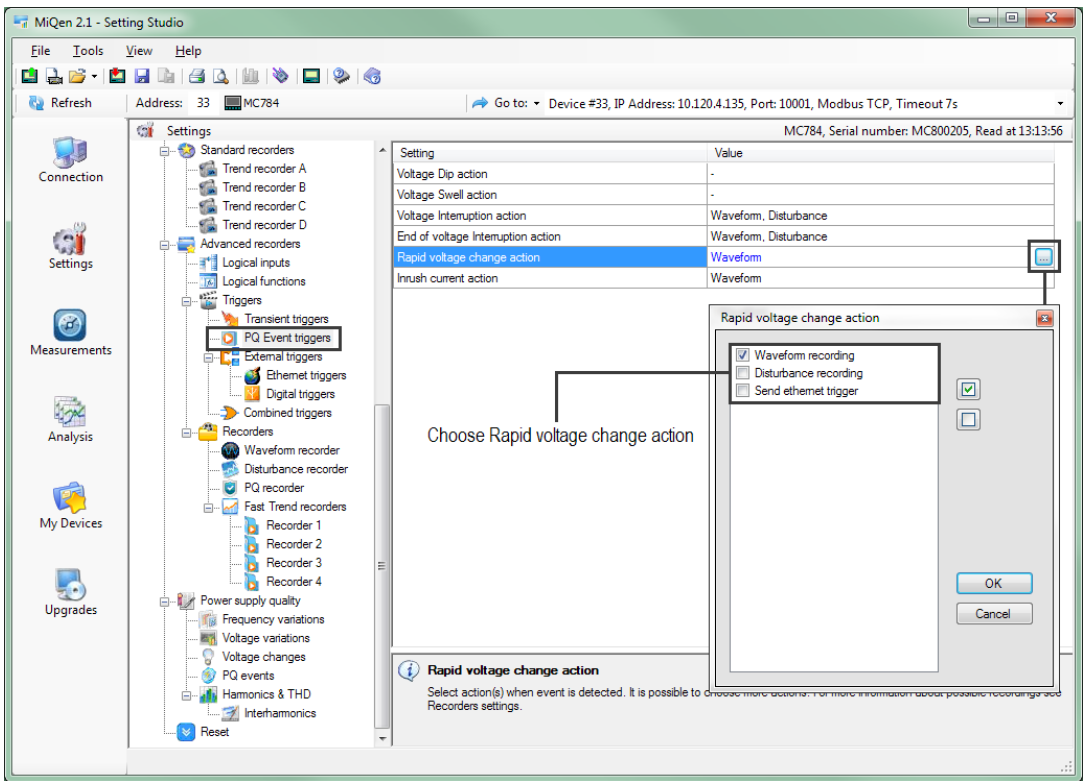

Defining Rapid voltage change action (QDSP2.1): Settings – Advanced recorders – Triggers – PQ Event triggers

All three options can be triggered at the same time.

**Inrush Current**

Large current flow that exceeds the steady-state current flow. It flows transiently at the time of starting of instruments (which have built-in motor), incandescent lamp, larger capacity smoothing condenser. ISTAT M365A/M365B with its Inrush current trigger is capable of detecting and recording inrush current events. Later analysis of gathered data can help us determine the cause of event. Knowing the cause, appropriate measures can be taken to prevent similar faults in the future. This is important since inrush current can result in bad effect to power switch's welding, fusing, breaker's trip and converter circuit etc. and also causes unstable power voltage.

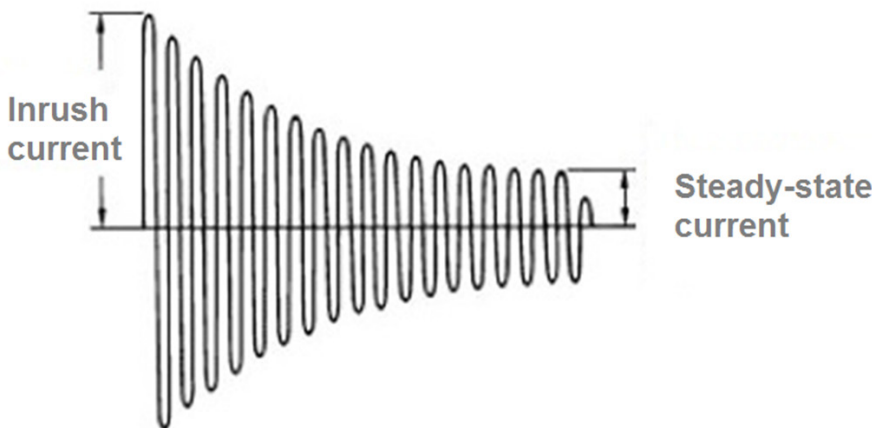

Inrush Current

Inrush current action:

- Waveform recording (detection of Inrush current triggers Waveform recording)
- Disturbance recording (detection of Inrush current triggers Disturbance recording)
- Send Ethernet trigger (detection of Inrush current triggers Send Ethernet trigger)

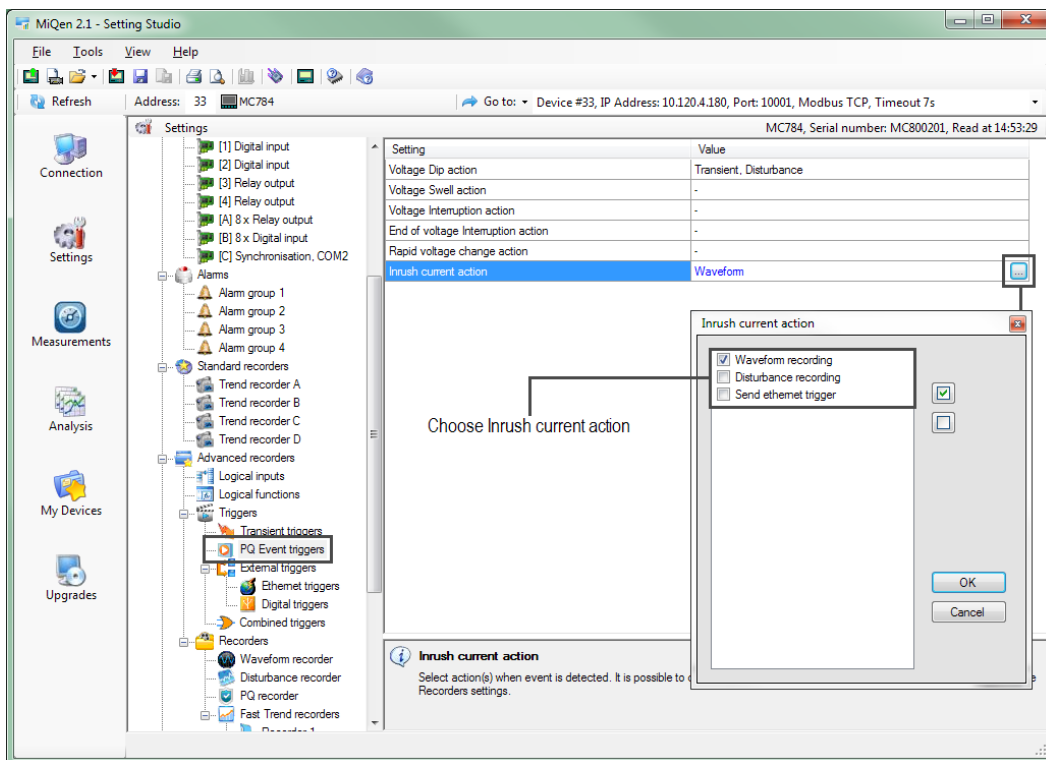

Defining Inrush current action (QDSP2.1): Settings – Advanced recorders – Triggers – PQ Event triggers

All three options can be triggered at the same time.

## External triggers

### Ethernet triggers

Upon event detection, a trigger can be sent to other devices over Ethernet. These are termed network triggers. Devices receiving Ethernet trigger will respond accordingly, so that an event or a disturbance at one network node results in instantaneously measured values at all other network nodes. This enables simultaneous analysis of the effect of the disturbance on the complete network. Up to 8 different dislocated devices can be connected one to another and exchange Ethernet triggers.

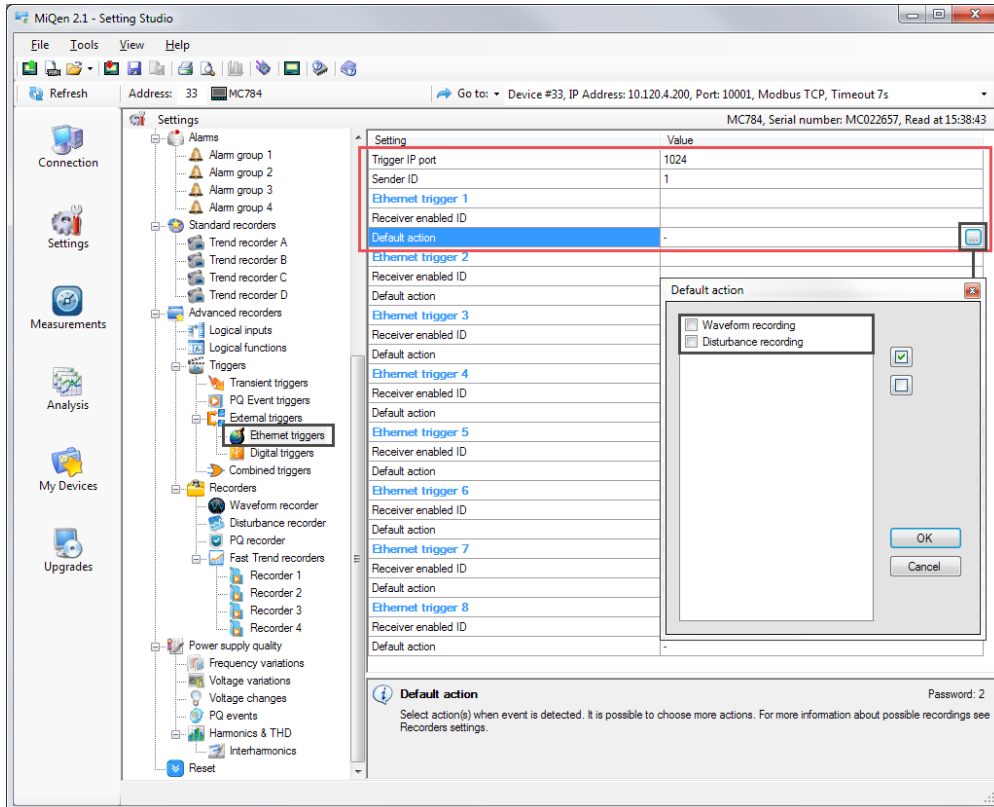

Defining Ethernet triggers parameters (QDSP2.1): Settings – Advanced recorders – Triggers – External triggers – Ethernet triggers

Following parameters have to be defined to enable Ethernet triggers:

- **Trigger IP port:**  
Select port for Ethernet triggers. Devices with same port are able to exchange Ethernet triggers. When device in utility network detects anomaly and sends Ethernet trigger, other devices (with same port) will receive that trigger – up to 8 devices.  
Range: 1024 – 65535
- **Sender ID:**  
Select identification number of the device. Identification number enables us to distinguish between devices in order to determine which device has sent which Ethernet trigger.  
Range: 1 – 255
- **Receiver enabled ID:**  
Select ID number of another into utility network connected device from which Ethernet triggers shall be accepted. To disable network triggering from another device this setting should be cleared.  
Range: 0 – 255
- **Default action:**  
Choose what happens when Ethernet trigger is detected. Both options can be triggered at the same time.  
Options: Waveform recording and Disturbance recording.

## Digital triggers

External digital triggers are based on logical/digital inputs.

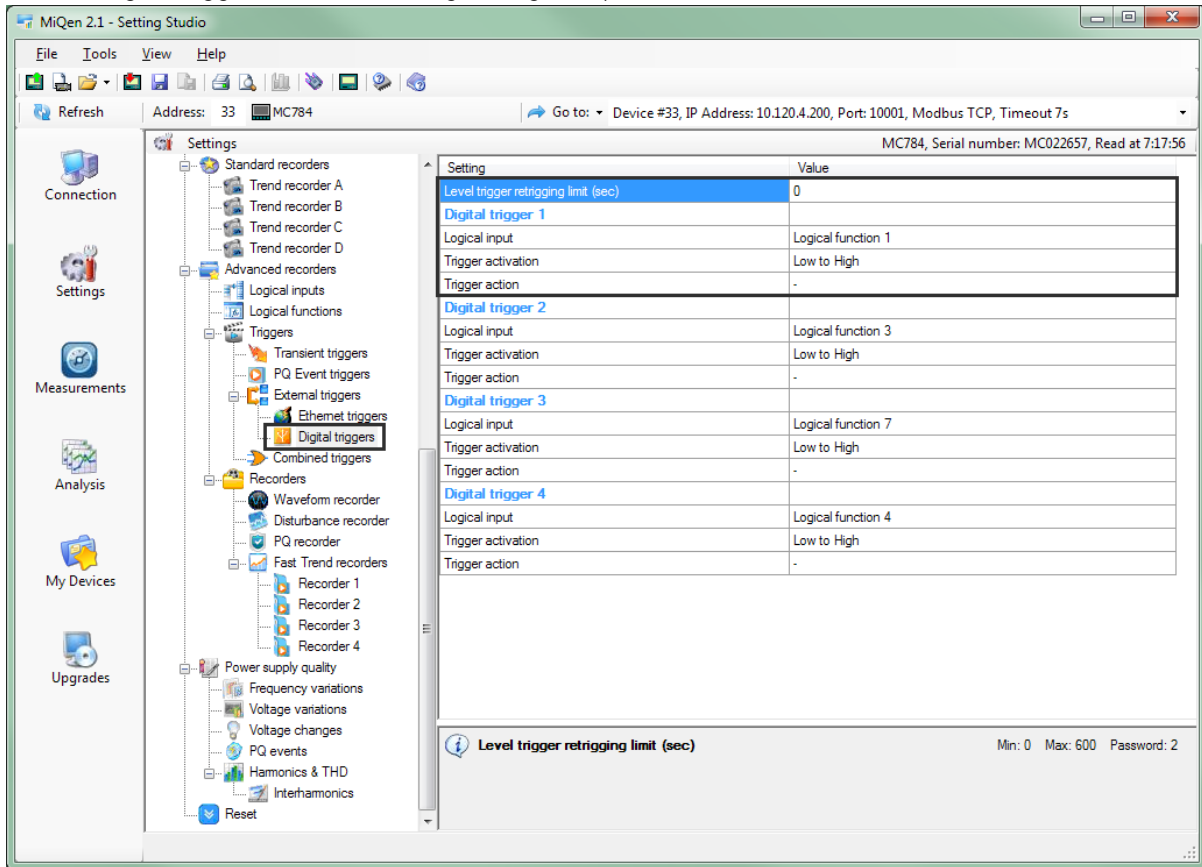

Defining Digital triggers parameters (QDSP2.1): Settings – Advanced recorders – Triggers – External triggers – Digital triggers

Following parameters have to be defined to enable Digital triggers:

- Level trigger re-triggering limit:  
If *High level* is chosen as *Trigger activation* then *Level trigger re-triggering limit* defines recording time for Level trigger. Range: 0 – 600s. Multiple recordings (Waveform/Disturbance recordings) will be stitched together until desired recording time is reached.

Example:

– Digital trigger 1 settings:

Level trigger retriggering limit (sec)	40
Digital trigger 1	
Logical input	Logical input 1
Trigger activation	High Level
Trigger action	Waveform
Digital trigger 2	

– Waveform recorder settings:

Setting	Value
Data format	Pqdf
Recorder resolution	625 samples / cycle (@50 Hz)
Recorded parameters	U1, U2, U3, Un, I1, I2, I3, In, Log
Pretrigger time (s)	0,5
Posttrigger time (s)	3,5

Waveform recording time = Pre-trigger time + Post-trigger time = 4s. To achieve 40s recording time for level trigger, 10 waveform recordings are stitched together.

If any other option is selected as Trigger activation (Low to High, High to Low, Each change, Low Level) recording time will be the same as predefined recording time of Waveform/disturbance recorder. Level trigger retriggering limit does not affect these options.

- Logical input:  
Select source for Digital trigger. Choose between logical inputs and logical functions.

Setting	Value
Level trigger retriggering limit (sec)	0
<b>Digital trigger 1</b>	
Logical input	Logical function 1
Trigger activation	Logical input 3
Trigger action	Logical input 4
<b>Digital trigger 2</b>	
Logical input	Logical input 6
Trigger activation	Logical input 7
Trigger action	Logical input 8
<b>Digital trigger 3</b>	
Logical input	Logical input 9
Trigger activation	Logical input 10
Trigger action	Logical input 11
<b>Digital trigger 4</b>	
Logical input	Logical input 12
Trigger activation	Logical input 13
Trigger action	Logical input 14
	Logical input 15
	Logical input 16
	Logical function 1
	Logical function 2
	Logical function 3
	Logical function 4
	Logical function 5
	Logical function 6
	Logical function 7
	Logical function 8
	Logical function 9
	Logical function 10
	Logical function 11
	Logical function 12
	Logical function 13
	Logical function 14
	Logical function 15
	Logical function 16

- Trigger activation:  
Select logical level transition direction for trigger activation.

Setting	Value
Level trigger retriggering limit (sec)	0
<b>Digital trigger 1</b>	
Logical input	Logical function 1
Trigger activation	Low to High
Trigger action	Low to High
<b>Digital trigger 2</b>	
Logical input	High to Low
Trigger activation	Each change
Trigger action	High Level
	Low Level
	Low to High
	-
<b>Digital trigger 3</b>	
Logical input	Logical function 7
Trigger activation	Low to High
Trigger action	-
<b>Digital trigger 4</b>	
Logical input	Logical function 4
Trigger activation	Low to High
Trigger action	-

- Trigger action:  
Choose what happens when Digital trigger is detected. All options can be chosen simultaneously.  
Options: Waveform recording, Disturbance recording and Send Ethernet trigger

Total of 4 Digital triggers can be defined.

### Combined triggers

Combined triggers give as an option to perform AND/OR logical operations over previously configured triggers/events. Total of 16 combined triggers can be defined.

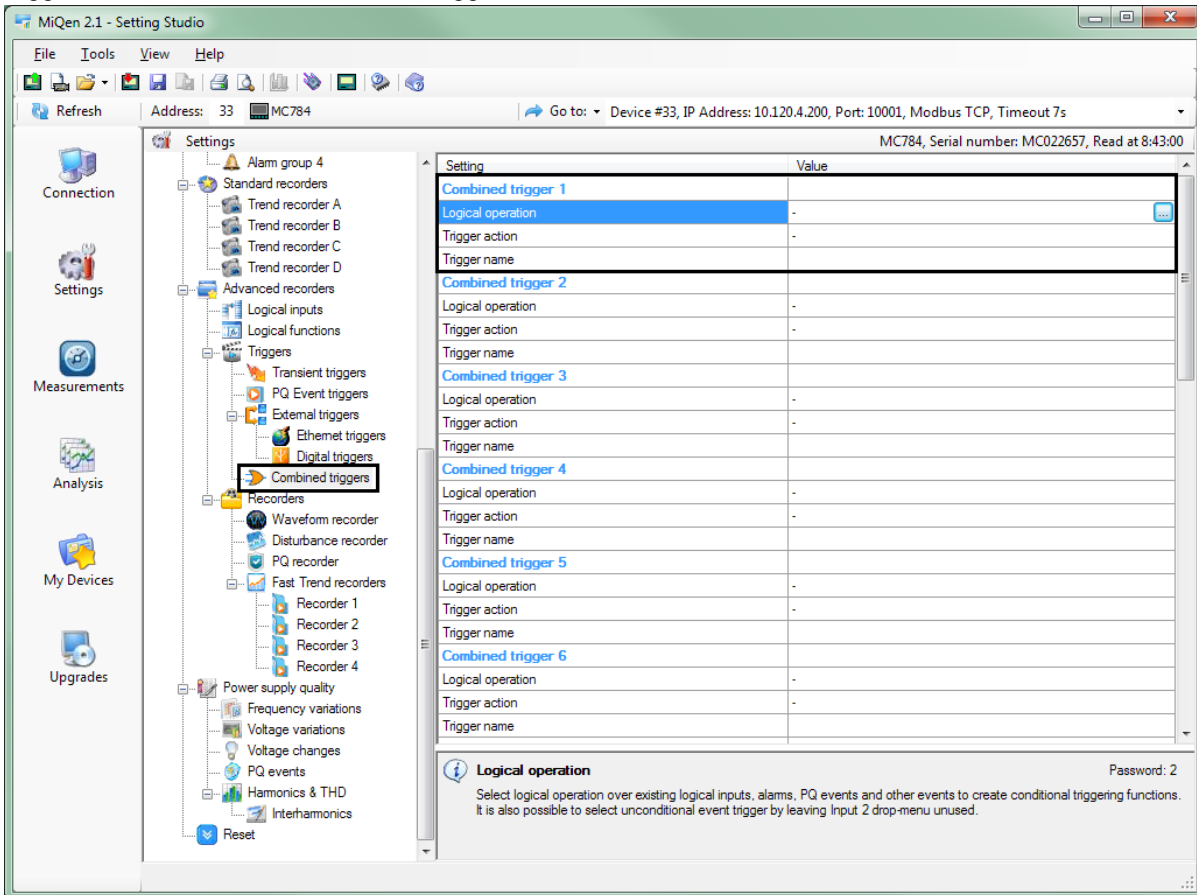

Defining Combined triggers parameters (QDSP2.1): Settings – Advanced recorders – Triggers – Combined triggers

Following parameters have to be defined to enable combined trigger:

- Logical operation:  
Create logical operation over existing logical inputs, alarms, PQ events and other events to create conditional triggering functions. Both Gate input 1 and Gate input 2 must be selected from a drop down menu. If Gate input 1/Gate input 2 is left empty, nothing will get recorded.

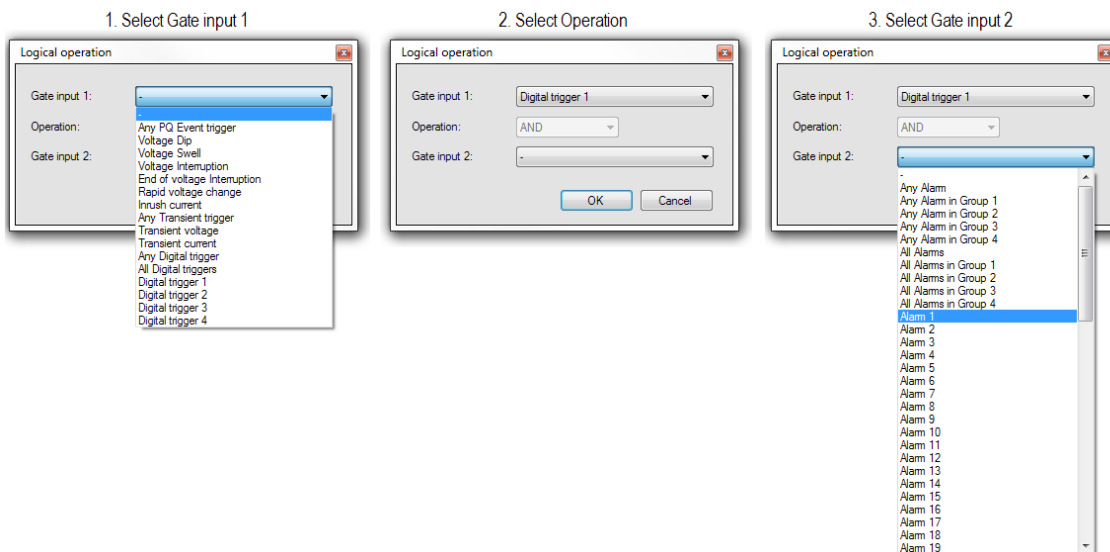

- Trigger action:  
Choose what happens when combined trigger is detected. All options can be chosen simultaneously.  
Options: Waveform recording, Disturbance recording and Send Ethernet trigger
- Trigger name:  
Select combined trigger name for presentation of (complex) conditional trigger. This name will be used within reports, where trigger condition and time stamp for each event will be recorded and presented. It should be a short and meaningful summary of combined trigger purpose or meaning.

---

 **PLEASE NOTE**

---

If Gate input 1/Gate input 2 is left empty, nothing will get recorded.  
Gate input 2 condition must be met in time when Gate input 1 is triggered, for Combined trigger to be activated.

---

## Recorders

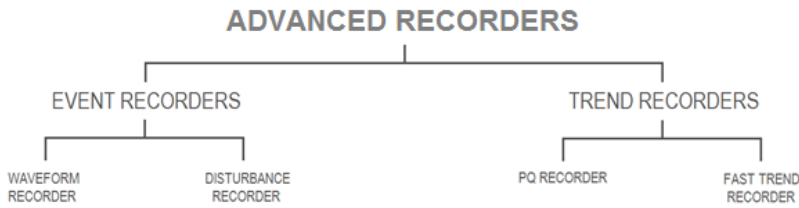

Following parameters have to be defined to enable data storage to specific recorder:

Setting	Value
Waveform recorder state	Active
Disturbance recorder state	Active
PQ recorder state	Active
Fast Trend recorder 1 state	Active
Fast Trend recorder 2 state	Active
Fast Trend recorder 3 state	Active
Fast Trend recorder 4 state	Active

**Fast Trend recorder 4 state**  
Defines if data is recording to selected recorder type.

Activate specific recorder

### Waveform recorder

It is an event recorder. Recorder is triggered only when an event occurs. It is used for monitoring short events (transients, short power quality events).

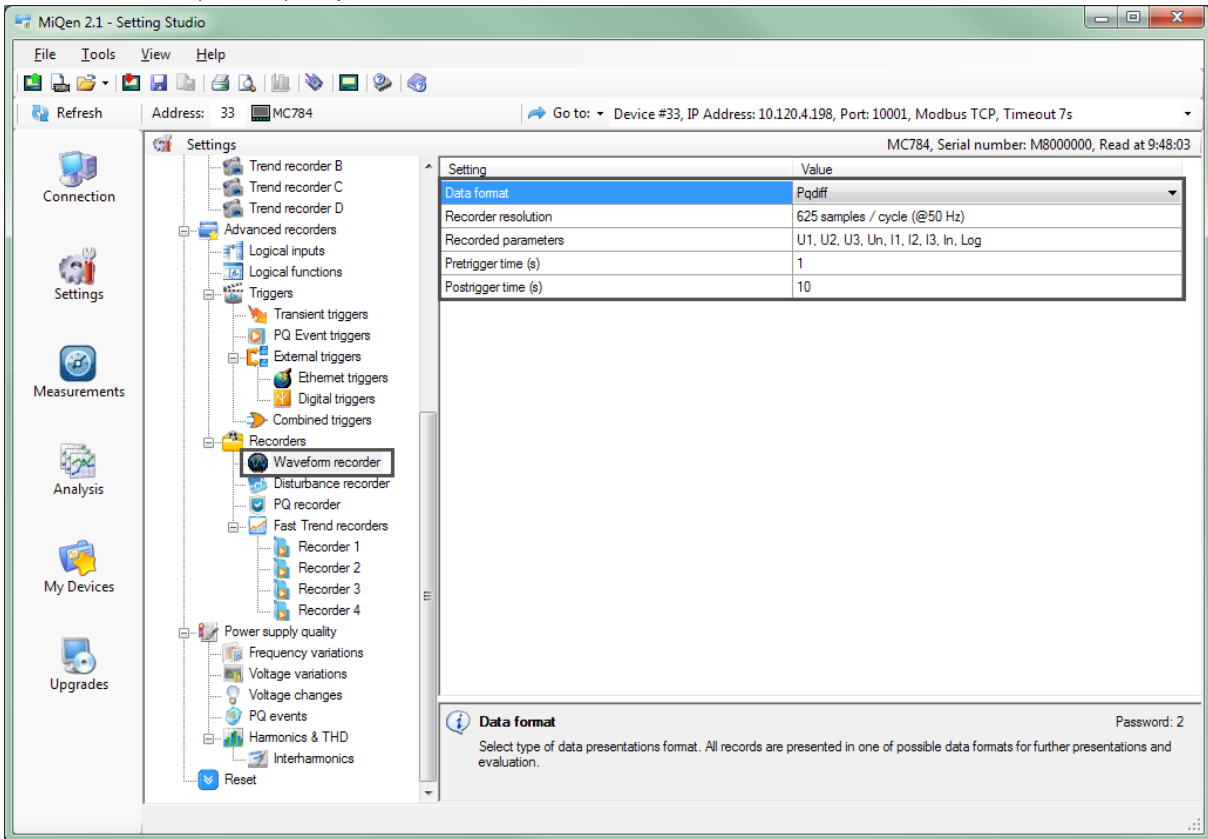

Defining Waveform recorder parameters (QDSP2.1): Settings – Advanced recorders – Recorders – Waveform recorder

Defining Waveform recorder parameters:

- Data format:  
Recorded data can be stored in PQDIF/COMTRADE data format. Only one can be selected for specific recorder.

Setting	Value
Data format	Pdqiff
Recorder resolution	Pdqiff
Recorded parameters	Comtrade
Pretrigger time (s)	1
Postrigger time (s)	10

Note: for more information on PQDIF/COMTRADE data format see chapter Measurements - PQDIF and COMTRADE files on M365B – concept description.

- Recorder resolution:  
Oscillography has the capability of recording waveforms with up to 625 samples per cycle (50Hz). Select among predefined resolutions.

Setting	Value
Data format	Pdqiff
Recorder resolution	625 samples / cycle (@50 Hz)
Recorded parameters	19 samples / cycle (@50 Hz)
Pretrigger time (s)	39 samples / cycle (@50 Hz)
Postrigger time (s)	78 samples / cycle (@50 Hz)
	156 samples / cycle (@50 Hz)
	312 samples / cycle (@50 Hz)
	625 samples / cycle (@50 Hz)

Note: to record transients select highest resolution.

- Recorder parameters:  
Select channels to record.

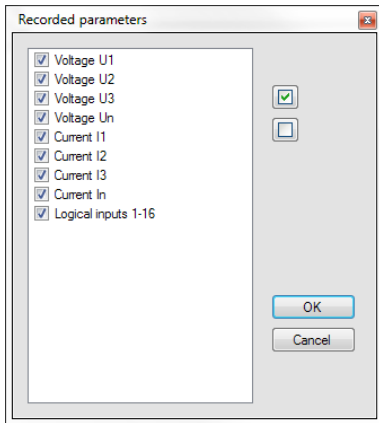

- Pre-trigger/post-trigger time:  
In some cases it is necessary to capture signal before and/or after a trigger occurs to analyze the behavior of the signal. In such cases you can use the pre-trigger or post-trigger feature to specify duration of the recording after/before trigger.

Setting	Value
Data format	Pqdiff
Recorder resolution	625 samples / cycle (@50 Hz)
Recorded parameters	U1, U2, U3, Un, I1, I2, I3, In, Log
Pretrigger time (s)	1
Posttrigger time (s)	10

Range:

Pre-trigger time: 0.01s – 1s

Post-trigger time: 0.01s – 40s (up to 20s for 625 samples/cycle)

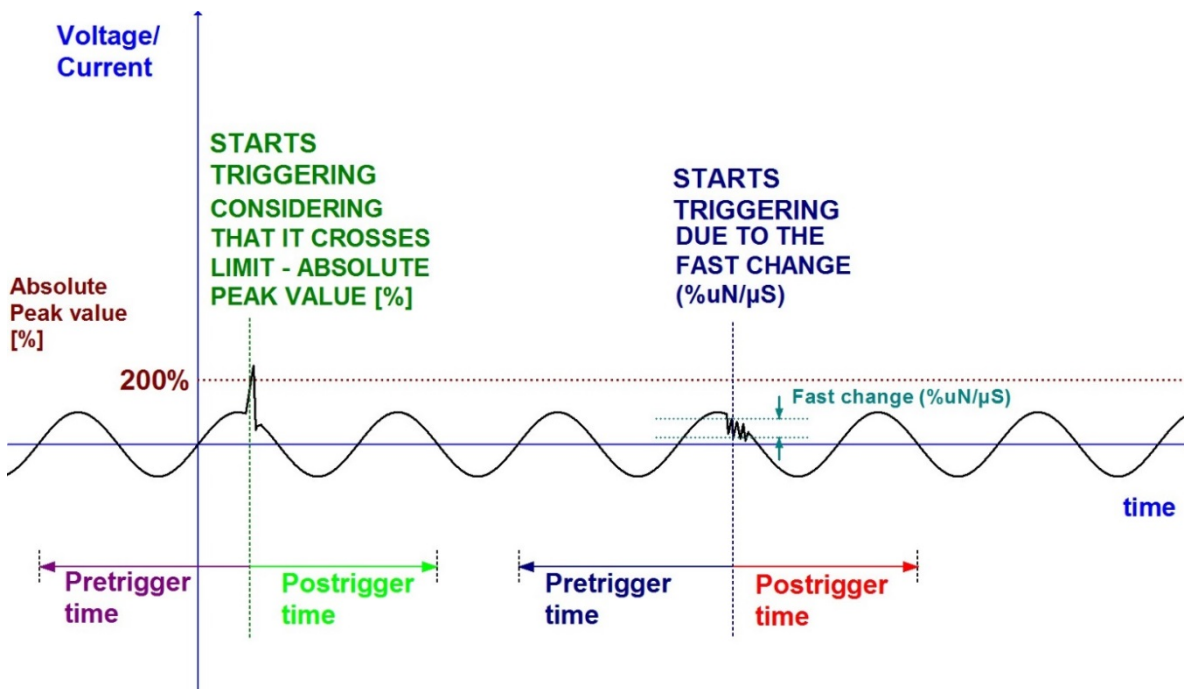

Pre-trigger and post-trigger time

Note: In some cases when predefined recorder post-trigger time is shorter than interruption duration time, only start of interruption will be recorded. In cases like that End of voltage interruption trigger will activate another recording that will capture end of event.

### Disturbance recorder

Disturbance recorder is an event recorder used for monitoring long term disturbances. Every half/full cycle, RMS value is calculated based on previous cycle.

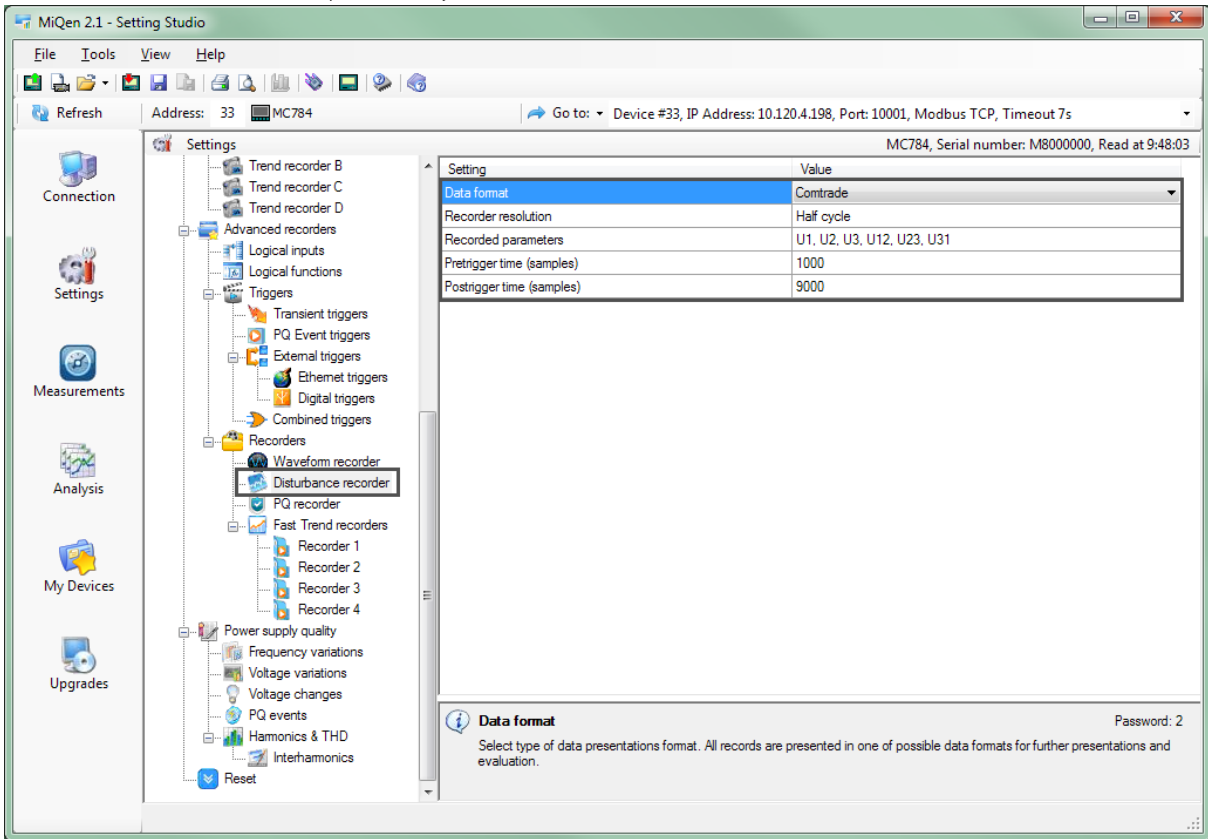

Defining Disturbance recorder parameters (QDSP2.1): Settings – Advanced recorders – Recorders – Disturbance recorder

Defining Disturbance recorder parameters:

- Data format:  
Recorded data can be stored in PQDIF/COMTRADE data format. Only one can be selected for specific recorder.

Setting	Value
Data format	Comtrade
Recorder resolution	Pqdiff
Recorded parameters	Comtrade
Pretrigger time (samples)	1000
Postrigger time (samples)	9000

Note: for more information on PQDIF/COMTRADE data format see chapter Measurements - PQDIF and COMTRADE files on M365B – concept description.

- Recorder resolution:  
Every half/full cycle, RMS value is calculated based on previous cycle. Select among predefined resolutions.

Setting	Value
Data format	Comtrade
Recorder resolution	Half cycle
Recorded parameters	Half cycle
Pretrigger time (samples)	1000
Postrigger time (samples)	9000

- Recorder parameters:  
Select channels to record.

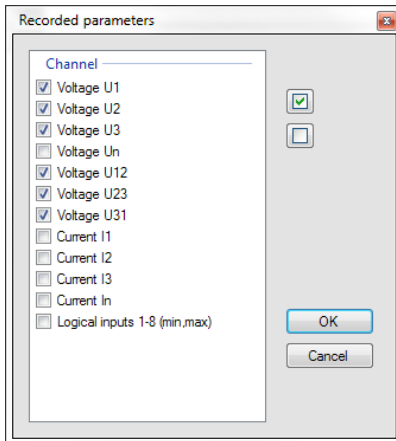

- Pre-trigger/post-trigger time:  
In some cases it is necessary to capture signal before and/or after a trigger occurs to analyze the behavior of the signal. In such cases you can use the pre-trigger or post-trigger feature to specify duration of the recording after/before trigger.

Setting	Value
Data format	Comtrade
Recorder resolution	Half cycle
Recorded parameters	U1, U2, U3, U12, U23, U31
Pretrigger time (samples)	1000
Posttrigger time (samples)	9000

Range:

- Pre-trigger time: 1 – 3000 samples
- Post-trigger time: 1 – 60000 samples

**PQ recorder**

PQ recorder is trend recorder used for monitoring PQ events. PQ records are stored for later analysis and generated based on a PQ event triggering mechanism. Event parameters are stored at predefined time intervals.

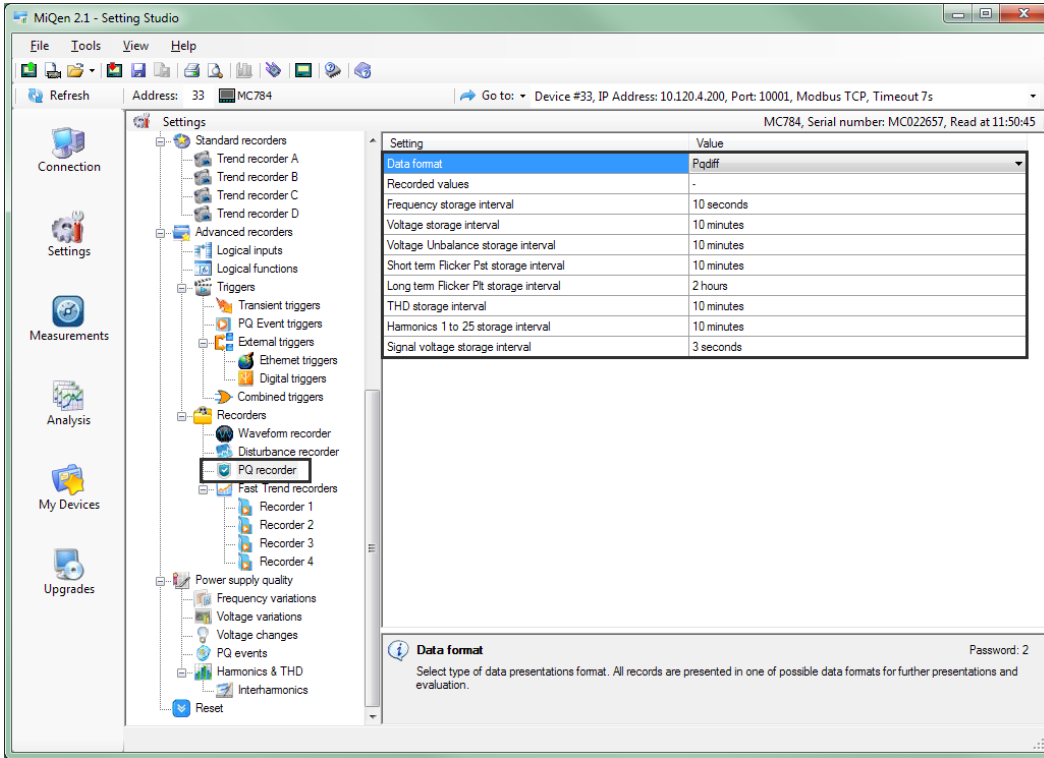

Defining PQ recorder parameters (QDSP2.1): Settings – Advanced recorders – Recorders – PQ recorder

Defining PQ recorder parameters:

- Data format:  
Recorded data can only be stored in PQDIF data format.
- Recorded values  
Values can be recorded as average/minimum/maximum RMS values. All three options can be selected at the same time.

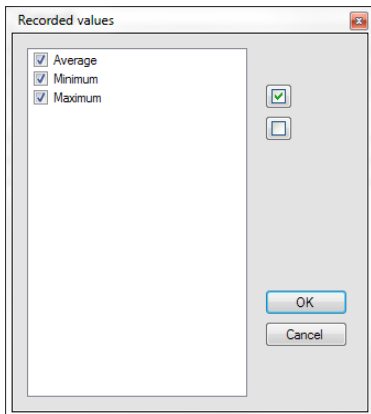

- Storage intervals for parameters below are specified in standard IEC EN 61000-4-30 (see chapter Power supply quality):
  - Frequency storage interval (10 seconds/No recording),
  - Voltage storage interval (10 minutes/No recording),
  - Voltage Unbalance storage interval (10 minutes/No recording),
  - Short term Flicker Pst storage interval (10 minutes/No recording),
  - Long term Flicker Plt storage interval (2 hours/No recording),
  - THD storage interval (10 minutes/No recording),
  - Harmonics 1 to 25 storage interval (10 minutes/No recording) and
  - Signal voltage storage interval (3 seconds/No recording).

Specific recorder is activated by choosing predefined storage interval.

Setting	Value
Data format	Pqdiff
Recorded values	-
Frequency storage interval	10 seconds
Voltage storage interval	10 minutes
Voltage Unbalance storage interval	10 minutes
Short term Flicker Pst storage interval	No recording
Long term Flicker Plt storage interval	10 minutes
THD storage interval	10 minutes
Harmonics 1 to 25 storage interval	10 minutes
Signal voltage storage interval	3 seconds

Choose predefined storage interval to enable recorder

### Fast Trend recorders

Fast trend recorder is trend recorder used for continuous recording of selected parameters.

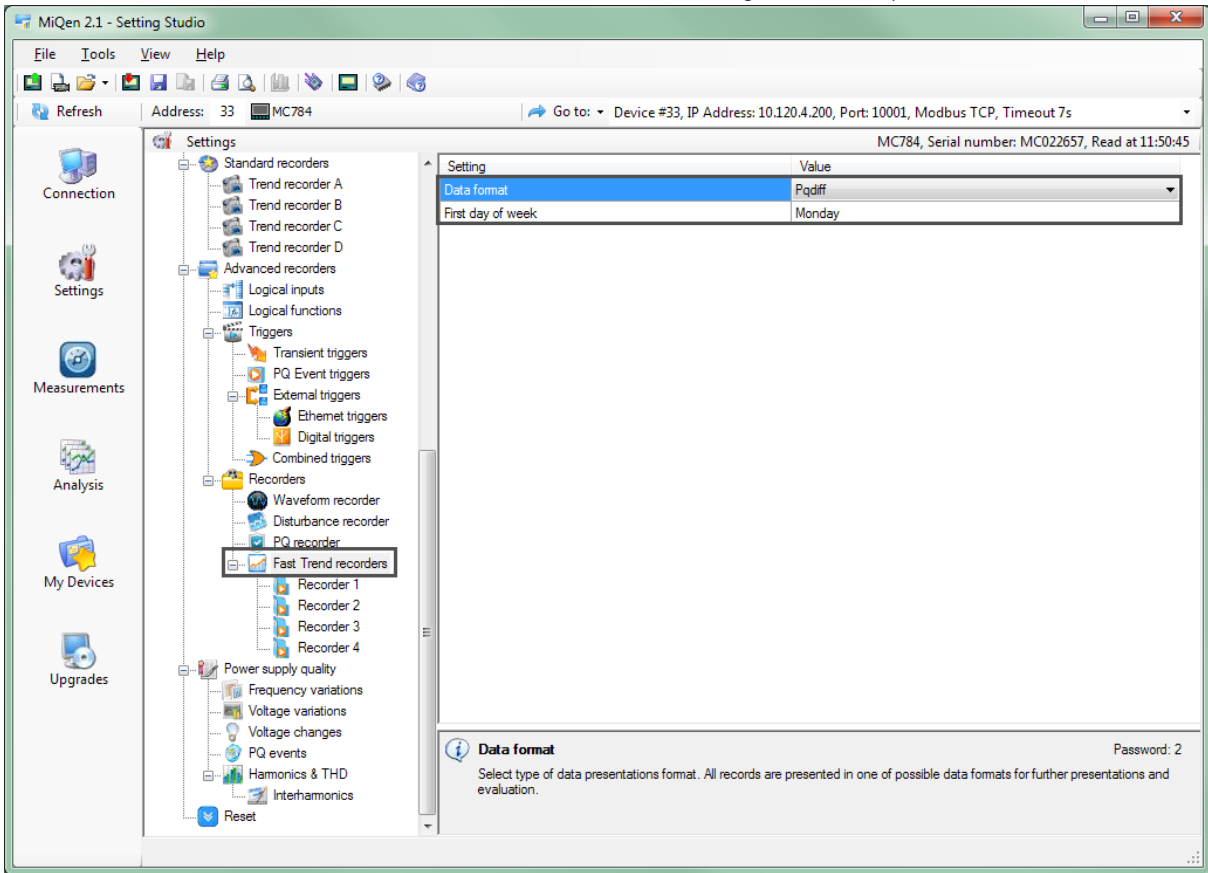

Defining Fast trend recorder parameters (QDSP2.1): Settings – Advanced recorders – Recorders – Fast trend recorder

Defining Fast trend recorder parameters:

- Data format:  
Recorded data can only be stored in PQDIF data format.
- First day of week:  
Define on which day of week data files will be generated (when selected file generation period is weekly).

Total of 4 recorders can be defined. Each with its own set of specific settings.

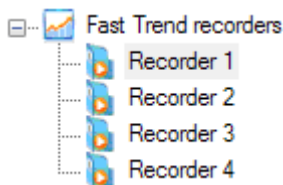

Defining Fast trend recorder – Recorder 1 parameters:

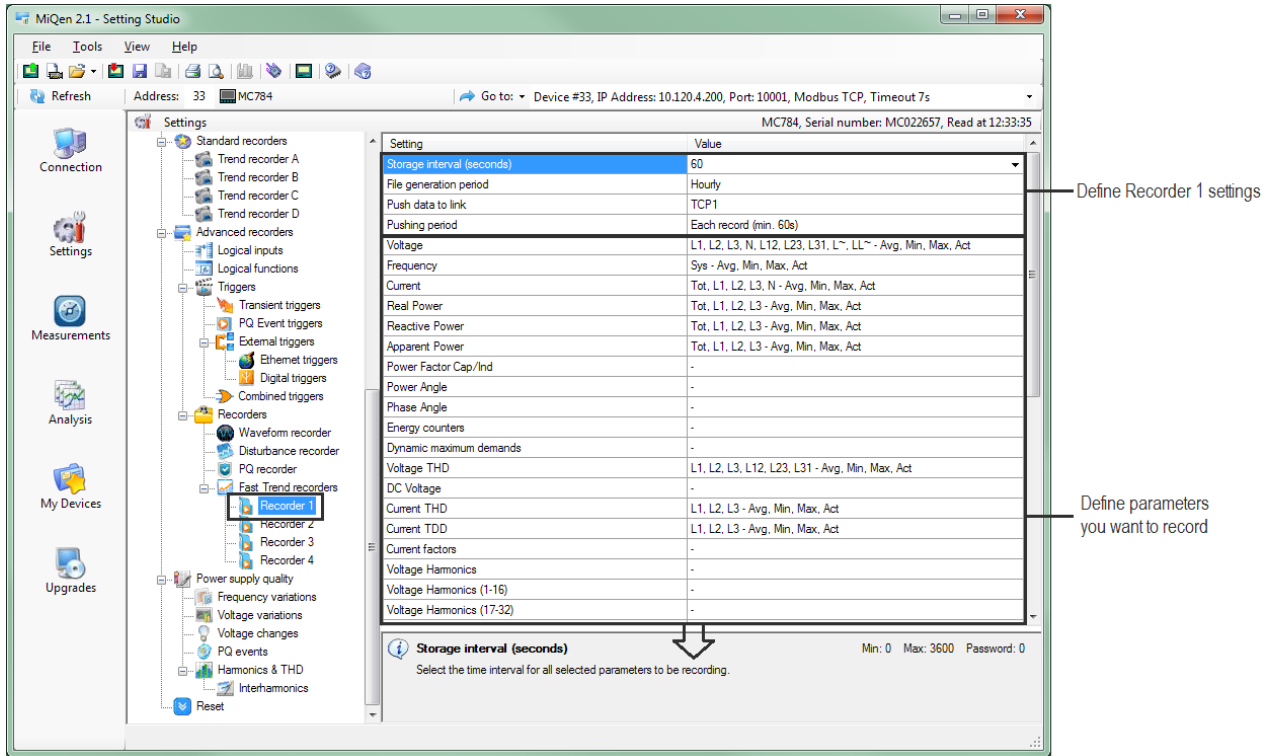

Defining Fast trend recorder – Recorder 1 parameters: Settings – Advanced recorders – Recorders – Fast trend recorder – Recorder 1

- Storage interval:  
Range: 1 – 3600 s  
Select among predefined storage intervals or manually enter storage interval of value lower than 10s.  
Example – storage interval of 60s means every 60s RMS value of each selected parameter will be stored.

Setting	Value
Storage interval (seconds)	60
File generation period	No recording
Push data to link	10
Pushing period	30
Voltage	300
Frequency	600
Current	900
Real Power	3600
Reactive Power	Tot, L1, L2, L3, N - Avg, Min, Max, Act
Apparent Power	Tot, L1, L2, L3 - Avg, Min, Max, Act

Select No recording to disable recorder.

**PLEASE NOTE**

When 1s storage interval is chosen it is advised not to select all measurements. This especially applies to harmonics/interharmonic measurements whit large amount of measurements.

- File generation period:  
 Select among predefined periods:
  - Hourly – data files are generated every hour
  - Daily – data files are generated every day at midnight
  - Weekly – data files are generated every week on previously selected day at midnight (*Settings – Advanced recorders – Recorders – Fast trend recorders – First day of week*)
  - Monthly – data files are generated every month on previously selected day at midnight (*Settings – Advanced recorders – Recorders – Fast trend recorders – First day of week*)

Setting	Value
Storage interval (seconds)	60
File generation period	Hourly
Push data to link	Hourly
Pushing period	Daily
Voltage	Weekly
	Monthly
Frequency	Sys - Avg, Min, Max, Act
Current	Tot, L1, L2, L3, N - Avg, Min, Max, Act
Real Power	Tot, L1, L2, L3 - Avg, Min, Max, Act
Reactive Power	Tot, L1, L2, L3 - Avg, Min, Max, Act
Apparent Power	Tot, L1, L2, L3 - Avg, Min, Max, Act
Power Factor Cap/Ind	-

- Measurements:  
Define parameters you want to record.

Voltage	L1, L2, L3, N, L12, L23, L31, L <sup>~</sup> , LL <sup>~</sup> - Avg, Min, Max, Act
Frequency	Sys - Avg, Min, Max, Act
Current	Tot, L1, L2, L3, N - Avg, Min, Max, Act
Real Power	Tot, L1, L2, L3 - Avg, Min, Max, Act
Reactive Power	Tot, L1, L2, L3 - Avg, Min, Max, Act
Apparent Power	Tot, L1, L2, L3 - Avg, Min, Max, Act
Power Factor Cap/Ind	-
Power Angle	-
Phase Angle	-
Energy counters	-
Dynamic maximum demands	-
Voltage THD	L1, L2, L3, L12, L23, L31 - Avg, Min, Max, Act
DC Voltage	-
Current THD	L1, L2, L3 - Avg, Min, Max, Act
Current TDD	L1, L2, L3 - Avg, Min, Max, Act
Current factors	-
Voltage Harmonics	-
Voltage Harmonics (1-16)	-
Voltage Harmonics (17-32)	-
Voltage Harmonics (33-48)	-
Voltage Harmonics (49-63)	-
Current Harmonics	-
Current Harmonics (1-16)	-
Current Harmonics (17-32)	-
Current Harmonics (33-48)	-
Current Harmonics (49-63)	-
Voltage Interharmonics	-
Voltage Interharmonics (1-10)	-
Signalling voltage	-
Voltage unbalances	-
Flickers Pi	-
Flickers Pst	-
Flickers Plt	-
Voltage Underdeviation	-
Voltage Overdeviation	-
Analogue inputs	-
Digital inputs	-
Digital inputs - Module A	-
Digital inputs - Module B	-

Example:

- Voltage

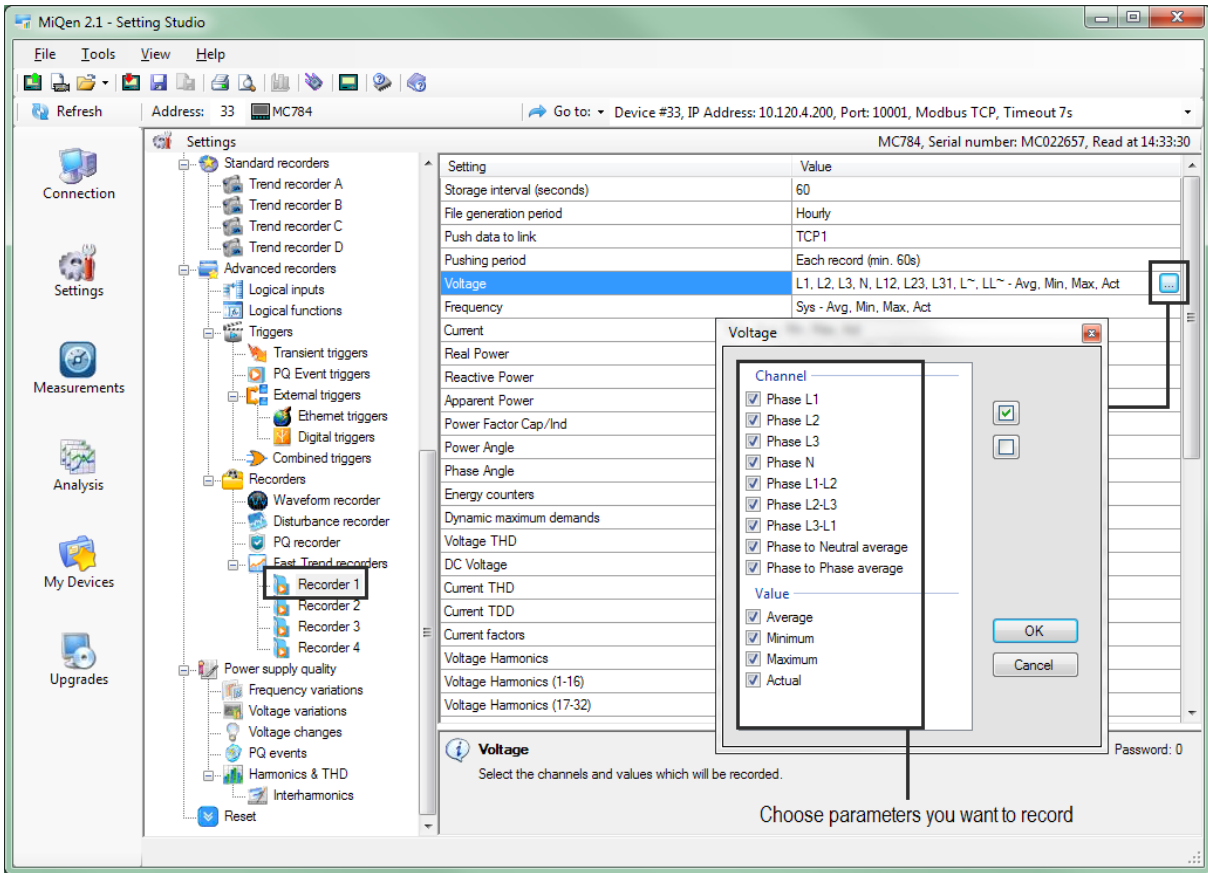

Same principal applies to other three recorders.

## Conformity of voltage with EN 50160 standard

The EN 50160 standard deals with voltage characteristics of electricity supplied by public distribution systems. It specifies the limits or values of voltage characteristics in normal operation within public low or middle voltage system network. Following this definition the measuring instrument is adapted for monitoring voltage characteristics of a distribution systems according to EN 50160 standard. Together with setting and monitoring software QDSP2.1 voltage characteristics can be monitored and weekly reports about power quality are issued.

Based on requirements stated in the standard, default parameters are set in the device according to which supervision of all required characteristics is performed. Parameters can also be changed in detailed settings for individual characteristics.

### CAUTION

Factory default settings for PQ characteristics are in compliance with standard EN 50160. By changing individual parameters conformity of weekly reports with this standard is no longer valid.

Parameters of PQ characteristics are settable only by means of QDSP2.1 setting software.

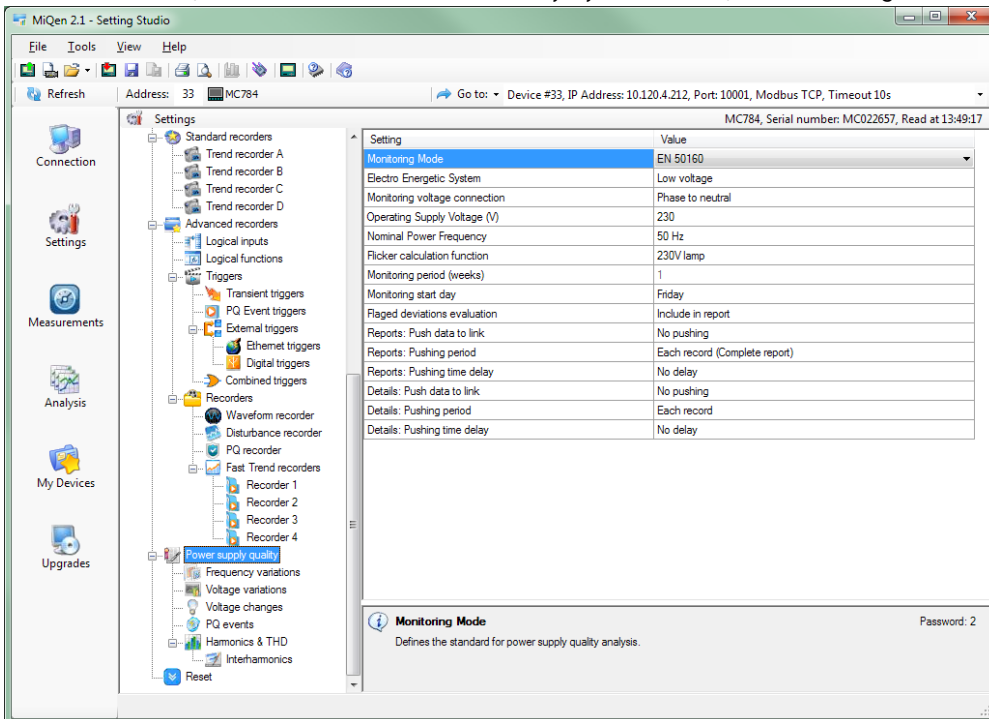

## General PQ settings

General PQ settings are basic parameters that influence other settings.

### Monitoring mode

Monitoring mode can be set to:

- EN50160: Monitoring according to EN 50160 enabled. Weekly reports are issued according to set parameters
- No monitoring: Weekly reports for network compliance with the standard are disabled

### Electro energetic system

Requirements for PQ monitoring differ regarding type of a monitored public distribution system. Therefore it is essential to choose proper type. This setting influences some of the predefined limit lines according to relevant standard EN 50160.

Measuring instrument can monitor PQ within following systems:

- Low Voltage grid connected system
- Medium Voltage grid connected system
- Low Voltage islanded system
- Medium Voltage islanded system

---

** PLEASE NOTE**

Choosing one of listed distribution systems automatically sets PQ characteristics according to requirements in EN 50160 for that particular system.

---

### *Monitoring voltage connection*

When using 4u (3 phase 4 wire) connection mode, there is an option to choose between Phase to neutral or Phase to phase Monitoring voltage. Both are supported.

When using 3u (3 phase 3 wire) connection mode, Phase to phase Monitoring voltage is set automatically.

---

** PLEASE NOTE**

When using 3u connection mode or Phase to phase monitoring at 4u connection, Nominal supply voltage has to be set accordingly to your phase to phase nominal network voltage.

---

### *Nominal supply voltage*

Set a voltage level of a monitored system. This value is used as a reference for calculation of power quality indices and is usually equal to nominal network voltage (also marked as  $U_{\text{din}}$  in various standards). Factory default value is EU standard low voltage value 230 V.

### *Nominal power frequency*

Nominal frequency of monitored supply voltage is selected. Factory default value is EU standard frequency 50Hz. It is also possible to choose 60 Hz.

### *Flicker calculation function*

Low voltage level for residential lamps can be either 230V or 110V. Function for detection of flicker differs regarding this voltage. Since actual low voltage level can be different as secondary voltage of used VT (nominal measuring voltage) this setting must be set to a voltage level, which is used to supply residential lamps.

### *Monitoring period (weeks)*

Monitoring period predefines period for issuing PQ reports. When Monitoring Mode is set to EN 50160, monitoring is performed continuously.

This setting defines how often should reports be issued.

### Monitoring start day

A starting day in a week for monitoring period is selected. It starts at 00:00 (midnight) in the selected day. The selected day will be the first day in a report.

After Monitoring period and Monitoring start day are defined, PQ reports will be continuously issued at the end of each monitoring period. All reports and associated anomalies within monitored period are stored in devices internal memory and can be analyzed by means of QDSP2.1 software.

### Flagged events setting

Flagged events setting specifies actions on data (recorded events) that has been flagged (marked) according to flagging concept IEC 61000-4-30.

Flagged data are power quality records, which has been influenced by one or more voltage events (interruptions, dips, swells).

The purpose of flagging data is to mark recorded parameters when certain disturbances might influenced measurements and caused corrupted data. For example, voltage dip can also trigger occurrence of flicker, inter-harmonics... In this case all parameters which were recorded at a time of voltage events are marked (flagged). In later evaluation those flagged records can be omitted from final report by choosing appropriate setting.

#### **PLEASE NOTE**

Regardless of this setting, readings will be always stored in recorder and available for analysis. Flagging only influences PQ reports as a whole.

The screenshot shows the 'MiQen 2.1 - Setting Studio' window. The left sidebar contains navigation icons for Connection, Settings, Measurements, Analysis, My Devices, and Upgrades. The main area displays a tree view of settings under 'Settings', with 'Triggers' expanded to show 'Flagged deviations evaluation'. The right pane shows a table of settings for device MC784, with the 'Flagged deviations evaluation' setting selected and its dropdown menu open, showing options: 'Include in report', 'Exclude from report', and 'Each record (complete report)'. Below the table, a tooltip for 'Flagged deviations evaluation' explains that it specifies actions on data according to IEC 61000-4-30.

Setting	Value
Monitoring Mode	EN 50160
Electro Energetic System	Low voltage
Monitoring voltage connection	Phase to neutral
Operating Supply Voltage (V)	230
Nominal Power Frequency	50 Hz
Flicker calculation function	230V lamp
Monitoring period (weeks)	1
Monitoring start day	Friday
Flagged deviations evaluation	Include in report
Reports: Push data to link	Include in report
Reports: Pushing period	Exclude from report
Reports: Pushing time delay	Each record (complete report)
Details: Push data to link	No delay
Details: Pushing period	No pushing
Details: Pushing time delay	Each record
Details: Pushing time delay	No delay

**Flagged deviations evaluation** Password: 2  
Specifies actions on data (recorded events) that has been flagged according to flagging concept IEC 61000-4-30.

Flagged data can be included or excluded from a PQ report

## EN 50160 parameters settings

Power Quality indices as defined by EN 50160

Phenomena	PQ Parameters
Frequency variations	Frequency distortion
Voltage variations	Voltage fluctuation
	Voltage unbalance
Voltage changes	Rapid voltage changes
	Flicker
Voltage events	Voltage dips
	Voltage interruptions
	Voltage swells
Harmonics & THD	THD
	Harmonics
	Inter-harmonics
	Signaling voltage

Standard EN 50160 describes in details PQ parameters and corresponding limit lines for monitoring whereas distribution system voltage operates in accordance with mentioned standard.

Settings of limit lines and required percentage of appropriate indices resembles requirements of standard EN 50160. When monitoring according to this standard is required there is no need to make changes to PQ parameters settings. More detailed description of certain parameter monitoring procedures is in a chapter *Measurements*.

There are some PQ parameters which are interesting for monitoring but are not required to be part of PQ reports. These settings do not have standardized limit values and can be set according to distribution network requirements.

- Short term flicker (limit Pst = 1)
- Interharmonics (10 values of user defined frequencies)

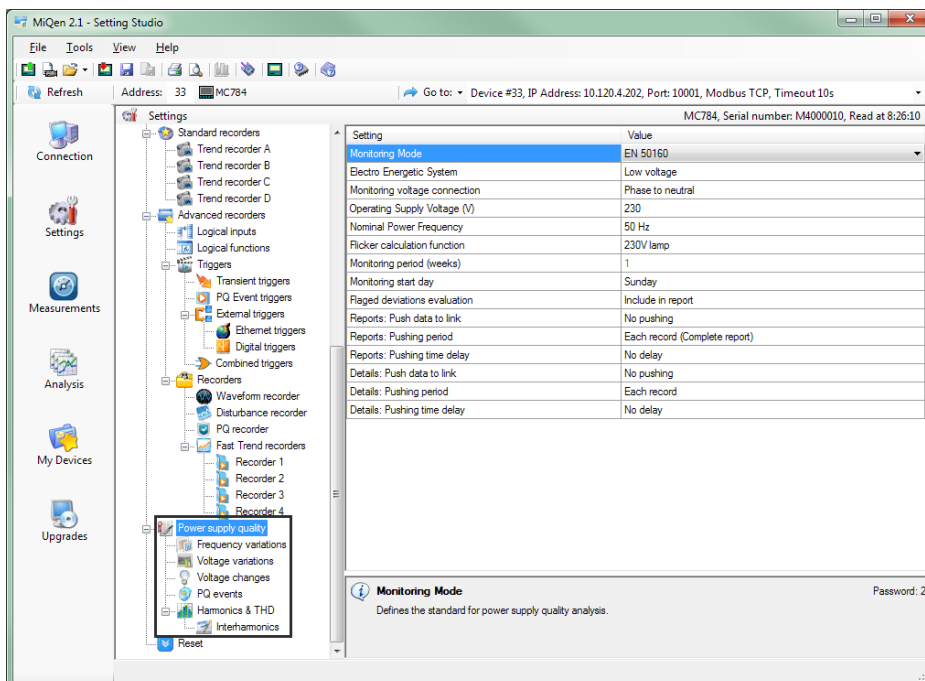

Settings for power quality parameters are set with setting and monitoring software QDSP2.1

QDSP.2.1 HELP description clearly marks PQ parameters, which are not required as a part of EN 50160 PQ report. Below figure shows settings for interharmonic values:

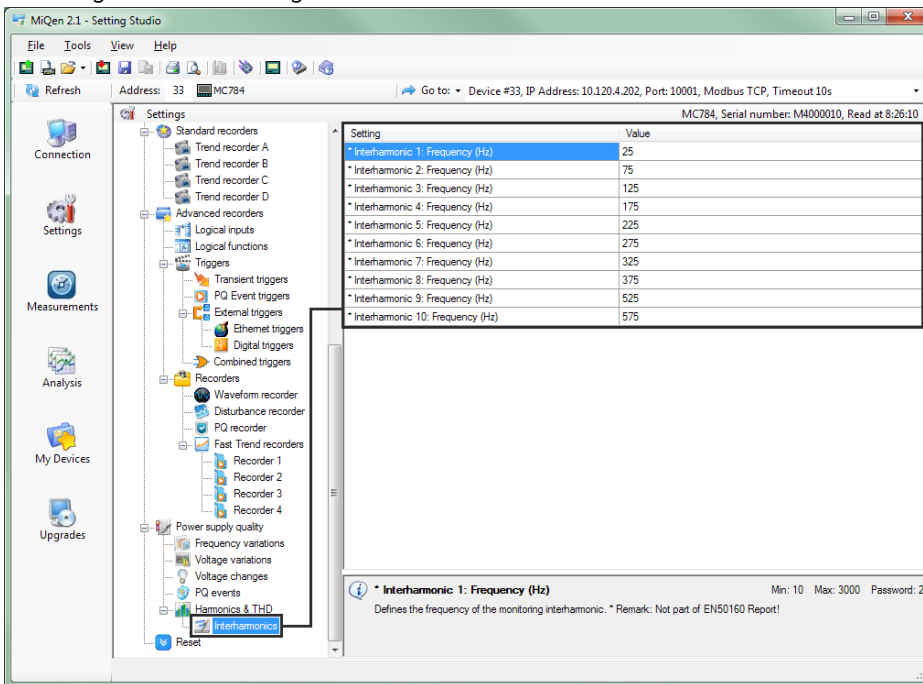

Settings for 10 user defined interharmonic frequencies

## Reset

During normal operation, a user may wish to reset various counters.

### *Reset energy counter*

All or individual energy meters (counters) are reset.

### Reset energy counter Cost

All or individual energy costs are reset.

### Reset Maximum Demand (MD) Values

#### **Thermal mode:**

Current and stored MDs are reset.

#### **Fixed interval / sliding windows:**

The values in the current time interval, in all sub-windows for sliding windows and stored MD are reset. In the same time, synchronization of time interval to the beginning of the first sub-window is also performed.

### *Reset Last period MD*

#### **Thermal mode:**

Current MD value is reset.

#### **Fixed interval / sliding windows:**

Values in the current time interval and in all sub-windows for sliding windows are reset. In the same time, synchronization of the time interval is also performed.

### *Synchronize MD*

#### **Thermal mode:**

In this mode, synchronization does not have any influence.

#### **Fixed interval / sliding windows:**

Synchronization sets time in a period or a sub-period for sliding windows to 0 (zero). If the interval is set to 2, 3, 4, 5, 6, 10, 12, 15, 20, 30 or 60 minutes, time in a period is set to such value that some intervals will be terminated at completed hour.

Time constant (interval)	15 min	10 min	7 min
Synchronization start time	10:42	10:42	10:42
Time in a period	12 min	2 min	0 min
First final interval	10:45	10:50	10:49

### *Alarm relay [1/2/3/4] Off*

When using QDSP2.1, each alarm output can be reset separately. On device (manually) only all alarm outputs together can be reset.

### *Reset Min/Max values*

All Min/Max values are reset.





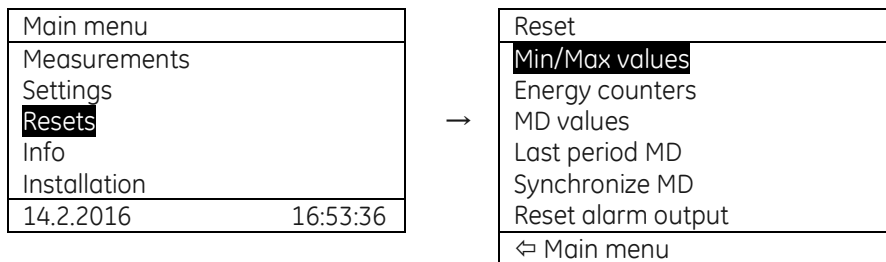

### *Reset alarm statistic*

Clears the alarm statistic. It can be made by QDSP2.1 software under Alarm settings. This setting is only for resetting online alarms statistics displayed in QDSP2.1 software.

## LCD navigation

### M365B



-  Main menu > Resets > Min/Max values > Yes/No
-  Main menu > Resets > Energy counters > All cost counters / All energy counters / Energy counter (E1 / E2 / E3 / E4) / Cost counter (E1 / E2 / E3 / E4)
-  Main menu > Resets > MD values > Yes/No
-  Main menu > Resets > Last period MD > Yes/No
-  Main menu > Resets > Synchronize MD > Yes/No
-  Main menu > Resets > Reset alarm output > Yes/No

### M365A

Reset commands for Power Quality Analyzer M365A can only be set in QDSP2.1 software. There are no options for Reset on device TFT display.

# Measurements

ISTAT M365A/M365B performs measurements with a constant sampling frequency of 31 kHz. Measurement methods differ for normal operation quantities, where values are averaged and aggregated according to aggregation requirements of the IEC 61000-4-30 standard (Class A). This also holds for voltage events where half-period values are evaluated in accordance with the same standard.

## Online measurements

Online measurements are available by using the device display or remotely:

- With the QDSP2.1 setting and analysis software
- With devices WEB server

Readings are continuously available on the display with refresh time dependent on the setup average interval whereas the reading rate of monitored values with QDSP2.1 is fixed, refreshing approximately every second.

For better overview over numerous readings, the readings are divided into several groups, which contain basic measurements, min. and max. values, alarms, harmonics, interharmonics and PQ parameters.

Each group can represent data in visually favored graphical form or in detailed tabelaric form. The latter allows freezing readings and/or copying data into various report generation software tools.

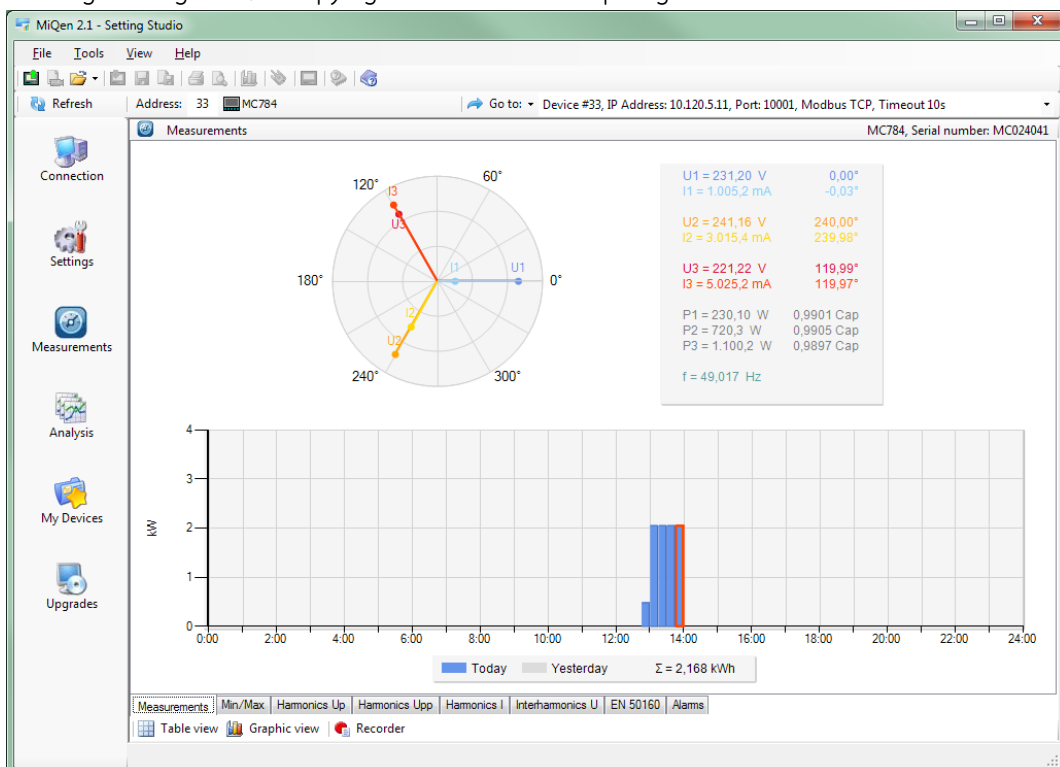

Example: Online measurements in graphical form - phasor diagram and daily total active power consumption histogram

Phase measurements		L1	L2	L3	Total	Others
Voltage		231.20 V	241.16 V	221.22 V		U <sup>~</sup> = 231.19 V
Current		1.005.2 mA	3.015.4 mA	5.025.2 mA	9.045.9 mA	I <sup>~</sup> = 3.015.3 mA
Real Power		230.10 W	720.3 W	1.100.2 W	2.050.6 W	
Reactive Power		-32.61 var	-100.0 var	-159.5 var	-292.0 var	
Apparent Power		232.40 VA	727.2 VA	1.111.7 VA	2.071.3 VA	
Power Factor		0.9901 Cap	0.9905 Cap	0.9897 Cap	0.9900 Cap	
Power Angle		-0.03 °	-0.02 °	-0.01 °	-8.11 °	
THD-Up		10.00 %	9.58 %	10.45 %		
THD-I		9.99 %	9.98 %	10.00 %		
TDD-I		1.99 %	5.99 %	10.00 %		
Kfactor		1.03	1.14	1.47		
Current Crest factor		143.3 %	148.1 %	143.0 %		
DC Voltage		0.06 V	0.05 V	0.02 V		
Phase to phase measurements		L1 - L2	L2 - L3	L3 - L1	Total	Others
Phase to phase voltage		408.45 V	399.89 V	391.17 V		U <sup>pp</sup> = 399.84 V
Phase Angle		120.00 °	120.00 °	119.99 °		
THD-Up		7.99 %	8.16 %	8.34 %		
DC Voltage		0.00 V	0.03 V	-0.03 V		
Neutral line		Measured	Angle	Calculated	Error	DC
Current		1.005.2 mA	-0.09 °	3.514.4 mA	2.717.6 mA	
Voltage		0.98 V	0.00 °			-0.07 V
Energy counters		Counter E1 (Exp)	Counter E2 (Exp)	Counter E3 (Imp)	Counter E4 (Imp)	Active tariff
Total		3.40 kWh	1.14 kvarh	0.56 kWh	0.75 kvarh	1
Tariff 1		3.40 kWh	1.14 kvarh	0.56 kWh	0.75 kvarh	
Tariff 2		-0.01 kWh	-0.01 kvarh	-0.01 kWh	-0.01 kvarh	
Tariff 3		-0.01 kWh	-0.01 kvarh	-0.01 kWh	-0.01 kvarh	
Tariff 4		-0.01 kWh	-0.01 kvarh	-0.01 kWh	-0.01 kvarh	
Energy cost		Counter E1, Cost	Counter E2, Cost	Counter E3, Cost	Counter E4, Cost	Total

Example: Online measurements in tabular form

## WEB server

ISTAT M365A/M365B supports WEB server for a fast and easy monitoring of devices' settings and online measurements. WEB server can be accessed by entering devices' IP number into your browsers' address bar. IP number can be obtained in communication settings on devices' display. WEB server can be accessed only when your computer is in the same local network as a device. Otherwise secure VPN tunnel has to be implemented to access devices' network.

Setting	Value
Type	M365 Waveform
Serial Number	MC028163
Software version	1.08
Hardware version	A
Accuracy class	0.1
Calibration voltage (V)	500 V
Voltage Voltage Auto Range	Yes
Calibration Current (A)	5 A
Calibration Current Auto Range	Yes
Power Supply	Universal AC
Communication	Enhanced Ethernet & USB
Memory size	8 Mb Flash
Display type	TFT 640 * 480
Input / Output 1	Watch dog output
Input / Output 2	Relay alarm output
Input / Output 3	Analog input
Input / Output 4	Analog input
Inputs / Outputs A	8 x Relay Output
Inputs / Outputs B	8 x Digital Input
Inputs / Outputs C	Synchronisation
Calibration date	08.03.2018
Last Configuration date	17.03.2018
Last Upgrade date	08.03.2018

Example: Presentation of settings within WEB server

Phase measurements	L1	L2	L3	Total	Others
Voltage	226.49 V	226.49 V	226.41 V		226.46 V
Current	18.72 A	13.60 A	24.98 A	57.30 A	19.10 A
Real Power	3.875 kW	2.762 kW	5.360 kW	11.997 kW	
Reactive Power	-1.719 kvar	-1.362 kvar	-1.806 kvar	-4.888 kvar	
Apparent Power	4.239 kVA	3.080 kVA	5.657 kVA	12.975 kVA	
Power Factor	0.9141 Cap	0.8969 Cap	0.9476 Cap	0.9246 Cap	
Power Angle	-4.82°	-10.74°	-11.56°	-22.17°	
Displacement Power Factor	0.9965 Cap	0.9825 Cap	0.9798 Cap	0.9871 Cap	
THD-Up	1.81%	1.67%	1.72%		
THD-I	42.85%	44.55%	25.92%		
TDD-I	0.73 %	0.55 %	0.62 %		
Deformed Power D	1.683 kvar	1.253 kvar	1.432 kvar	4.368 kvar	
K-factor	19.72	34.84	8.27		
Current Crest factor	215.9 %	250.7 %	192.5 %		
DC Voltage	0.03 V	0.03 V	0.00 V		
Phase to phase measurements	L1 - L2	L2 - L3	L3 - L1	Total	Others
Phase to phase voltage	392.30 V	392.28 V	392.14 V		392.24 V

Example: Presentation of online measurements within WEB server

## Interactive instrument

Additional communication features of the device allow interactive handling with a dislocated device as if it were operated directly through the on-board keyboard and display. This feature can also prove to be very useful for presentations or product training purposes.

### M365B

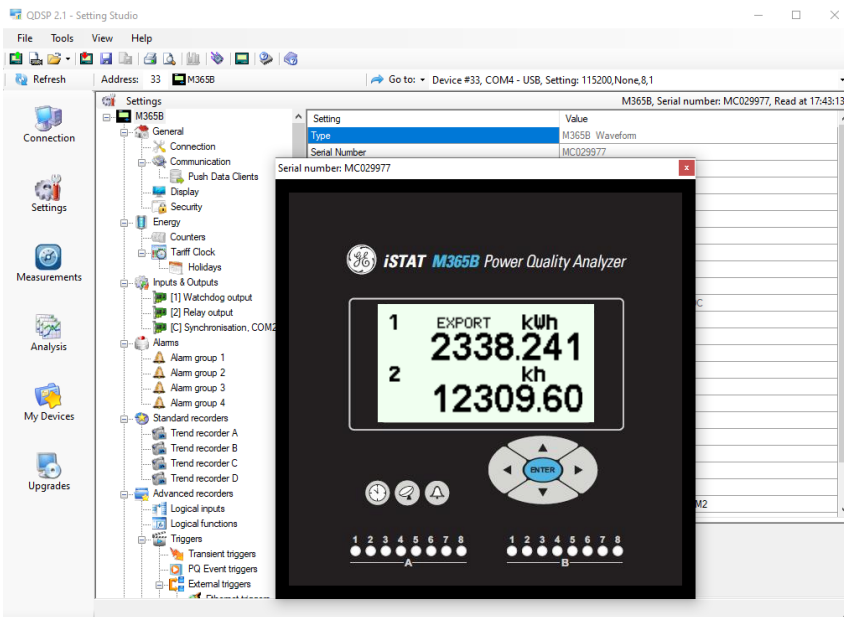

## Supported measurements

Selection of supported measurements of individual instrument types is changed within the connection settings. All supported measurements can be read via communication (through QDSP2.1) or displayed on the ISTAT M365A/M365B display (depending on hardware).

## Available connections

Different electric connections are described in more detail in chapter Electrical connection. Connections are marked as follows:

- Connection 1b (1W) – Single phase connection
- Connection 3b (1W3) – Three phase, three wire connection with balanced load
- Connection 4b (1W4) – Three phase, four wire connection with balanced load
- Connection 3u (2W3) – Three phase, three wire connection with unbalanced load
- Connection 4u (3W4) – Tree phase, four wire connection with unbalanced load

---

**⚠ PLEASE NOTE**

Measurements support depends on connection mode the device type. Calculated measurements (for example voltages  $U_1$  and  $U_2$  when 3-phase, 4-wire connection with a balanced load is used) are only informative.

---

## Selection of available quantities

Available online measuring quantities and their appearance can vary according to the setup type of power network and other settings such as; average interval, maximum demand mode and reactive power calculation method. A complete list of available online measuring quantities is shown in the table below.

---

**⚠ PLEASE NOTE**

Measurements support depends on connection mode as well as the ISTAT M365A/M365B type (built-in options). Calculated measurements (for example voltages  $U_1$  and  $U_2$  when 3-phase, 4-wire connection with a balanced load is used) are only informative.

---

---

**⚠ PLEASE NOTE**

For 3b and 3u connection mode, only phase to phase voltages are measured. The factor  $\sqrt{3}$  is then applied to calculate the nominal phase voltage. For 4u connection mode the same measurements are supported as for 1b.

---

Meas. type	Measurement	3-phase 4-wire	3-phase 3-wire	1-phase	comments
Phase measurements	<b>Voltage</b>				
	U <sub>1-3_RMS</sub>	<input checked="" type="checkbox"/>		<input checked="" type="checkbox"/> 1ph	
	U <sub>AVG_RMS</sub>	<input checked="" type="checkbox"/>		<input checked="" type="checkbox"/>	
	U <sub>unbalance_neg_RMS</sub>	<input checked="" type="checkbox"/>	<input checked="" type="checkbox"/>		
	U <sub>unbalance_zero_RMS</sub>	<input checked="" type="checkbox"/>			
	U <sub>1-3_DC</sub>	<input checked="" type="checkbox"/>		<input checked="" type="checkbox"/> 1ph	DC component of phase voltages
	U <sub>0_Zero_sequence_RMS</sub>	<input checked="" type="checkbox"/>	<input checked="" type="checkbox"/>		Zero sequence voltage
	U <sub>1_Positive_sequence_RMS</sub>	<input checked="" type="checkbox"/>	<input checked="" type="checkbox"/>		Positive sequence voltage
	U <sub>2_Negative_sequence_RMS</sub>	<input checked="" type="checkbox"/>	<input checked="" type="checkbox"/>		Negative sequence voltage
	<b>Current</b>				
	I <sub>1-3_RMS</sub>	<input checked="" type="checkbox"/>	<input checked="" type="checkbox"/>	<input checked="" type="checkbox"/> 1ph	
	I <sub>TOT_RMS</sub>	<input checked="" type="checkbox"/>	<input checked="" type="checkbox"/>	<input checked="" type="checkbox"/>	
	I <sub>AVG_RMS</sub>	<input checked="" type="checkbox"/>	<input checked="" type="checkbox"/>	<input checked="" type="checkbox"/>	
	I <sub>unbalance_RMS</sub>	<input checked="" type="checkbox"/>	<input checked="" type="checkbox"/>		
	I <sub>unbalance_zero_RMS</sub>	<input checked="" type="checkbox"/>	<input checked="" type="checkbox"/>		
	I <sub>0_Zero_sequence_RMS</sub>	<input checked="" type="checkbox"/>	<input checked="" type="checkbox"/>		Zero sequence current
	I <sub>1_Positive_sequence_RMS</sub>	<input checked="" type="checkbox"/>	<input checked="" type="checkbox"/>		Positive sequence current
	I <sub>2_Negative_sequence_RMS</sub>	<input checked="" type="checkbox"/>	<input checked="" type="checkbox"/>		Negative sequence current
	<b>Power</b>				
	P <sub>1-3_RMS</sub>	<input checked="" type="checkbox"/>		<input checked="" type="checkbox"/> 1ph	
P <sub>TOT_RMS</sub>	<input checked="" type="checkbox"/>	<input checked="" type="checkbox"/>	<input checked="" type="checkbox"/>		
Q <sub>1-3_RMS</sub>	<input checked="" type="checkbox"/>		<input checked="" type="checkbox"/> 1ph	Reactive power can be calculated as a squared difference between S and P or as sample delayed	
Q <sub>TOT_RMS</sub>	<input checked="" type="checkbox"/>	<input checked="" type="checkbox"/>	<input checked="" type="checkbox"/>		
Q <sub>b_t_RMS</sub>	<input checked="" type="checkbox"/>	<input checked="" type="checkbox"/>		Budeanu reactive power Total	
Q <sub>b1-3_RMS</sub>	<input checked="" type="checkbox"/>	<input checked="" type="checkbox"/>		Budeanu reactive power Phase	
S <sub>1-3_RMS</sub>	<input checked="" type="checkbox"/>		<input checked="" type="checkbox"/> 1ph		
S <sub>TOT_RMS</sub>	<input checked="" type="checkbox"/>	<input checked="" type="checkbox"/>	<input checked="" type="checkbox"/>		
D <sub>t_RMS</sub>	<input checked="" type="checkbox"/>	<input checked="" type="checkbox"/>		Deformed power Total	
D <sub>1-3_RMS</sub>	<input checked="" type="checkbox"/>	<input checked="" type="checkbox"/>		Deformed power Phase	
PF <sub>1-3_RMS</sub>	<input checked="" type="checkbox"/>		<input checked="" type="checkbox"/> 1ph		
dPF <sub>t_RMS</sub>	<input checked="" type="checkbox"/>	<input checked="" type="checkbox"/>		Displacement Power Factor Total	
dPF <sub>1-3_RMS</sub>	<input checked="" type="checkbox"/>	<input checked="" type="checkbox"/>		Displacement Power Factor Phase	
Φ <sub>1-3_RMS</sub>	<input checked="" type="checkbox"/>		<input checked="" type="checkbox"/> 1ph		
<b>Harmonic analysis</b>					
THD-U <sub>1-3</sub>	<input checked="" type="checkbox"/>		<input checked="" type="checkbox"/> 1ph		
THD-I <sub>1-3</sub>	<input checked="" type="checkbox"/>	<input checked="" type="checkbox"/>	<input checked="" type="checkbox"/> 1ph		
TDD-I <sub>1-3</sub>	<input checked="" type="checkbox"/>	<input checked="" type="checkbox"/>	<input checked="" type="checkbox"/> 1ph		
U <sub>1-3_harmonic_1-63_%</sub>	<input checked="" type="checkbox"/>		<input checked="" type="checkbox"/> 1ph	% of RMS or % of base	
U <sub>1-3_harmonic_1-63_ABS</sub>	<input checked="" type="checkbox"/>		<input checked="" type="checkbox"/> 1ph		
U <sub>1-3_harmonic_1-63_φ</sub>	<input checked="" type="checkbox"/>		<input checked="" type="checkbox"/> 1ph		
U <sub>1-3_inter-harmonic_%</sub>	<input checked="" type="checkbox"/>		<input checked="" type="checkbox"/> 1ph	Monitoring up to 10 different fixed frequencies	
U <sub>1-3_inter-harmonic_ABS</sub>	<input checked="" type="checkbox"/>		<input checked="" type="checkbox"/> 1ph		
U <sub>1-3_inter-harmonic_1-63_%</sub>	<input checked="" type="checkbox"/>		<input checked="" type="checkbox"/> 1ph	% of RMS or % of base	
U <sub>1-3_inter-harmonic_1-63_ABS</sub>	<input checked="" type="checkbox"/>		<input checked="" type="checkbox"/> 1ph		
U <sub>1-3_signaling_%</sub>	<input checked="" type="checkbox"/>		<input checked="" type="checkbox"/> 1ph	Monitoring of signaling (ripple) voltage of set frequency. % of RMS or % of base	
U <sub>1-3_signaling_ABS</sub>	<input checked="" type="checkbox"/>		<input checked="" type="checkbox"/> 1ph		
I <sub>1-3_harmonic_1-63_%</sub>	<input checked="" type="checkbox"/>	<input checked="" type="checkbox"/>	<input checked="" type="checkbox"/> 1ph	% of RMS or % of base	
I <sub>1-3_harmonic_1-63_ABS</sub>	<input checked="" type="checkbox"/>	<input checked="" type="checkbox"/>	<input checked="" type="checkbox"/> 1ph		
I <sub>1-3_harmonic_1-63_φ</sub>	<input checked="" type="checkbox"/>	<input checked="" type="checkbox"/>	<input checked="" type="checkbox"/> 1ph		
I <sub>1-3_inter-harmonic_%</sub>	<input checked="" type="checkbox"/>	<input checked="" type="checkbox"/>	<input checked="" type="checkbox"/> 1ph	Monitoring up to 10 different fixed frequencies	
I <sub>1-3_inter-harmonic_ABS</sub>	<input checked="" type="checkbox"/>	<input checked="" type="checkbox"/>	<input checked="" type="checkbox"/> 1ph		
I <sub>1-3_inter-harmonic_1-63_%</sub>	<input checked="" type="checkbox"/>	<input checked="" type="checkbox"/>	<input checked="" type="checkbox"/> 1ph	% of RMS or % of base	
I <sub>1-3_inter-harmonic_1-63_ABS</sub>	<input checked="" type="checkbox"/>	<input checked="" type="checkbox"/>	<input checked="" type="checkbox"/> 1ph		
I <sub>1-3_signaling_%</sub>	<input checked="" type="checkbox"/>		<input checked="" type="checkbox"/> 1ph	Monitoring of signaling (ripple) current of set frequency. % of RMS or % of base	
I <sub>1-3_signaling_ABS</sub>	<input checked="" type="checkbox"/>		<input checked="" type="checkbox"/> 1ph		
<b>Flickers</b>					
Pi <sub>1-3</sub>	<input checked="" type="checkbox"/>		<input checked="" type="checkbox"/> 1ph	Instantaneous flicker sensation measured with 150 samples / sec (original sampling is 1200 samples / sec)	
Pst <sub>1-3</sub>	<input checked="" type="checkbox"/>		<input checked="" type="checkbox"/> 1ph	10 min statistical evaluation (128 classes of CPF)	
Plt <sub>1-3</sub>	<input checked="" type="checkbox"/>		<input checked="" type="checkbox"/> 1ph	Derived from 12 Pst acc. to EN 61000-4-15	
<b>Miscellaneous</b>					
K-factor <sub>1-3</sub>	<input checked="" type="checkbox"/>	<input checked="" type="checkbox"/>	<input checked="" type="checkbox"/> 1ph		
Current Crest factor I <sub>1-3</sub>	<input checked="" type="checkbox"/>	<input checked="" type="checkbox"/>	<input checked="" type="checkbox"/> 1ph		
Voltage Crest factor U <sub>1-3</sub>	<input checked="" type="checkbox"/>	<input checked="" type="checkbox"/>	<input checked="" type="checkbox"/> 1ph		

Meas. type	Measurement	3-phase 4-wire	3-phase 3-wire	1-phase	comments
Phase to phase measurements	<b>Voltage</b>				
	Upp1-3_RMS	<input checked="" type="checkbox"/>	<input checked="" type="checkbox"/>		
	UppAVG_RMS	<input checked="" type="checkbox"/>	<input checked="" type="checkbox"/>		
	THD-Upp1-3	<input checked="" type="checkbox"/>	<input checked="" type="checkbox"/>		
	$\Phi_{x-y\_RMS}$	<input checked="" type="checkbox"/>			Phase-to-phase angle
	Upp1-3_harmonic_1-63_%	<input checked="" type="checkbox"/>	<input checked="" type="checkbox"/>	<input checked="" type="checkbox"/> 1ph	% of RMS or % of base
	Upp1-3_harmonic_1-63_ABS	<input checked="" type="checkbox"/>	<input checked="" type="checkbox"/>	<input checked="" type="checkbox"/> 1ph	
	Upp1-3_harmonic_1-63_op	<input checked="" type="checkbox"/>	<input checked="" type="checkbox"/>	<input checked="" type="checkbox"/> 1ph	
	Upp1-3_interharmonic_1-63_%	<input checked="" type="checkbox"/>	<input checked="" type="checkbox"/>	<input checked="" type="checkbox"/> 1ph	% of RMS or % of base
	Upp1-3_interharmonic_1-63_ABS	<input checked="" type="checkbox"/>	<input checked="" type="checkbox"/>	<input checked="" type="checkbox"/> 1ph	
	Uunderdeviation	<input checked="" type="checkbox"/>	<input checked="" type="checkbox"/>	<input checked="" type="checkbox"/> 1ph	U <sub>under</sub> and U <sub>over</sub> are calculated for phase or phase-to-phase voltages regarding connection mode.
	Uoverdeviation	<input checked="" type="checkbox"/>	<input checked="" type="checkbox"/>	<input checked="" type="checkbox"/> 1ph	
	Voltage Crest factor Upp1-3	<input checked="" type="checkbox"/>	<input checked="" type="checkbox"/>	<input checked="" type="checkbox"/> 1ph	
	<b>Flickers</b>				
	Pi_pp1-3		<input checked="" type="checkbox"/>		Phase-to-phase flickers.
Pst_pp1-3		<input checked="" type="checkbox"/>			
Plt_pp1-3		<input checked="" type="checkbox"/>			
Metering	<b>Energy</b>	<input checked="" type="checkbox"/>	<input checked="" type="checkbox"/>	<input checked="" type="checkbox"/>	
	Counter E1-8	<input checked="" type="checkbox"/>	<input checked="" type="checkbox"/>	<input checked="" type="checkbox"/>	Each counter can be dedicated to any of four quadrants (P-Q, import-export, L-C). Total energy is a sum of one counter for all tariffs. Tariffs can be fixed, date/time dependent or tariff input dependent
	E_TOT_1-8	<input checked="" type="checkbox"/>	<input checked="" type="checkbox"/>	<input checked="" type="checkbox"/>	
	Active tariff	<input checked="" type="checkbox"/>	<input checked="" type="checkbox"/>	<input checked="" type="checkbox"/>	
Auxiliary Channel measurements	<b>Aux. line</b>				
	INEUTRAL-EARTH	<input checked="" type="checkbox"/>		<input checked="" type="checkbox"/>	Aux. voltage is dedicated for neutral-earth meas. only
	INEUTRAL_meas	<input checked="" type="checkbox"/>		<input checked="" type="checkbox"/>	Measured neutral current with 4th current input
	INEUTRAL_calc	<input checked="" type="checkbox"/>	<input checked="" type="checkbox"/>	<input checked="" type="checkbox"/>	Calculated neutral current
	INEUTRAL_err	<input checked="" type="checkbox"/>		<input checked="" type="checkbox"/>	Error neutral current (difference between measured and calculated)
Maximum demand measurements	<b>Maximum demand</b>				
	MD_I1-3	<input checked="" type="checkbox"/>	<input checked="" type="checkbox"/>	<input checked="" type="checkbox"/> 1ph	
	MD_Pimport	<input checked="" type="checkbox"/>	<input checked="" type="checkbox"/>	<input checked="" type="checkbox"/>	
	MD_Pexport	<input checked="" type="checkbox"/>	<input checked="" type="checkbox"/>	<input checked="" type="checkbox"/>	
	MD_Qind	<input checked="" type="checkbox"/>	<input checked="" type="checkbox"/>	<input checked="" type="checkbox"/>	
	MD_Qcap	<input checked="" type="checkbox"/>	<input checked="" type="checkbox"/>	<input checked="" type="checkbox"/>	
Min and max measurements	<b>Min and max</b>				
	U1-3_RMS_MIN	<input checked="" type="checkbox"/>		<input checked="" type="checkbox"/> 1ph	
	U1-3_RMS_MAX	<input checked="" type="checkbox"/>		<input checked="" type="checkbox"/> 1ph	
	U0_Zero_sequence_RMS_MIN	<input checked="" type="checkbox"/>	<input checked="" type="checkbox"/>		Max/Min Zero sequence voltage
	U0_Zero_sequence_RMS_MAX	<input checked="" type="checkbox"/>	<input checked="" type="checkbox"/>		
	U1_Positive_sequence_RMS_MIN	<input checked="" type="checkbox"/>	<input checked="" type="checkbox"/>		Max/Min Positive sequence voltage
	U1_Positive_sequence_RMS_MAX	<input checked="" type="checkbox"/>	<input checked="" type="checkbox"/>		
	U2_Negative_sequence_RMS_MIN	<input checked="" type="checkbox"/>	<input checked="" type="checkbox"/>		Max/Min Negative sequence voltage
	U2_Negative_sequence_RMS_MAX	<input checked="" type="checkbox"/>	<input checked="" type="checkbox"/>		
	Upp1-3_RMS_MIN	<input checked="" type="checkbox"/>	<input checked="" type="checkbox"/>	<input checked="" type="checkbox"/>	
	Upp1-3_RMS_MAX	<input checked="" type="checkbox"/>	<input checked="" type="checkbox"/>	<input checked="" type="checkbox"/>	
	I1-3_RMS_MIN	<input checked="" type="checkbox"/>	<input checked="" type="checkbox"/>	<input checked="" type="checkbox"/> 1ph	
	I1-3_RMS_MAX	<input checked="" type="checkbox"/>	<input checked="" type="checkbox"/>	<input checked="" type="checkbox"/> 1ph	
	INEUTRAL_meas_RMS_MIN	<input checked="" type="checkbox"/>	<input checked="" type="checkbox"/>	<input checked="" type="checkbox"/>	
	INEUTRAL_meas_RMS_MAX	<input checked="" type="checkbox"/>	<input checked="" type="checkbox"/>	<input checked="" type="checkbox"/>	
	I0_Zero_sequence_RMS_MIN	<input checked="" type="checkbox"/>	<input checked="" type="checkbox"/>		Max/Min Zero sequence current
	I0_Zero_sequence_RMS_MAX	<input checked="" type="checkbox"/>	<input checked="" type="checkbox"/>		
	I1_Positive_sequence_RMS_MIN	<input checked="" type="checkbox"/>	<input checked="" type="checkbox"/>		Max/Min Positive sequence current
	I1_Positive_sequence_RMS_MAX	<input checked="" type="checkbox"/>	<input checked="" type="checkbox"/>		
	I2_Negative_sequence_RMS_MIN	<input checked="" type="checkbox"/>	<input checked="" type="checkbox"/>		Max/Min Negative sequence current
I2_Negative_sequence_RMS_MAX	<input checked="" type="checkbox"/>	<input checked="" type="checkbox"/>			

Meas. type	Measurement	3-phase 4-wire	3-phase 3-wire	1-phase	comments
Min and max measurements	P <sub>1-3</sub> _RMS_MIN	<input checked="" type="checkbox"/>		<input checked="" type="checkbox"/> 1ph	
	P <sub>1-3</sub> _RMS_MAX	<input checked="" type="checkbox"/>		<input checked="" type="checkbox"/> 1ph	
	P <sub>TOT</sub> _RMS_MIN	<input checked="" type="checkbox"/>	<input checked="" type="checkbox"/>	<input checked="" type="checkbox"/> 1ph	
	P <sub>TOT</sub> _RMS_MAX	<input checked="" type="checkbox"/>	<input checked="" type="checkbox"/>	<input checked="" type="checkbox"/> 1ph	
	Q <sub>B1</sub> _RMS_MIN	<input checked="" type="checkbox"/>	<input checked="" type="checkbox"/>		Max/Min Budeanu reactive power Total
	Q <sub>B1</sub> _RMS_MAX	<input checked="" type="checkbox"/>	<input checked="" type="checkbox"/>		
	Q <sub>B1-3</sub> _RMS_MIN	<input checked="" type="checkbox"/>	<input checked="" type="checkbox"/>		Max/Min Budeanu reactive power Phase
	Q <sub>B1-3</sub> _RMS_MAX	<input checked="" type="checkbox"/>	<input checked="" type="checkbox"/>		
	S <sub>1-3</sub> _RMS_MIN	<input checked="" type="checkbox"/>		<input checked="" type="checkbox"/> 1ph	
	S <sub>1-3</sub> _RMS_MAX	<input checked="" type="checkbox"/>		<input checked="" type="checkbox"/> 1ph	
	S <sub>TOT</sub> _RMS_MIN	<input checked="" type="checkbox"/>	<input checked="" type="checkbox"/>	<input checked="" type="checkbox"/> 1ph	
	S <sub>TOT</sub> _RMS_MAX	<input checked="" type="checkbox"/>	<input checked="" type="checkbox"/>	<input checked="" type="checkbox"/> 1ph	
	D <sub>L</sub> _RMS_MIN	<input checked="" type="checkbox"/>	<input checked="" type="checkbox"/>		Max/Min Deformed power Total
	D <sub>L</sub> _RMS_MAX	<input checked="" type="checkbox"/>	<input checked="" type="checkbox"/>		
	D <sub>1-3</sub> _RMS_MIN	<input checked="" type="checkbox"/>	<input checked="" type="checkbox"/>		Max/Min Deformed power Phase
	D <sub>1-3</sub> _RMS_MAX	<input checked="" type="checkbox"/>	<input checked="" type="checkbox"/>		
	dP <sub>F1</sub> _RMS_MIN	<input checked="" type="checkbox"/>	<input checked="" type="checkbox"/>		Max/Min Displacement Power Factor Total
	dP <sub>F1</sub> _RMS_MAX	<input checked="" type="checkbox"/>	<input checked="" type="checkbox"/>		
	dP <sub>F1-3</sub> _RMS_MIN	<input checked="" type="checkbox"/>	<input checked="" type="checkbox"/>		Max/Min Displacement Power Factor Phase
	dP <sub>F1-3</sub> _RMS_MAX	<input checked="" type="checkbox"/>	<input checked="" type="checkbox"/>		
freq <sub>MIN</sub>	<input checked="" type="checkbox"/>	<input checked="" type="checkbox"/>	<input checked="" type="checkbox"/>		
freq <sub>MAX</sub>	<input checked="" type="checkbox"/>	<input checked="" type="checkbox"/>	<input checked="" type="checkbox"/>		
Other measurements	Miscellaneous				
	Internal temp.	<input checked="" type="checkbox"/>	<input checked="" type="checkbox"/>	<input checked="" type="checkbox"/>	
	Date, Time	<input checked="" type="checkbox"/>	<input checked="" type="checkbox"/>	<input checked="" type="checkbox"/>	
	Last Sync. time	<input checked="" type="checkbox"/>	<input checked="" type="checkbox"/>	<input checked="" type="checkbox"/>	UTC
	GPS Time	<input checked="" type="checkbox"/>	<input checked="" type="checkbox"/>	<input checked="" type="checkbox"/>	If GPS receiver is connected to dedicated RTC time synchronization input
	GPS Longitude	<input checked="" type="checkbox"/>	<input checked="" type="checkbox"/>	<input checked="" type="checkbox"/>	
	GPS Latitude	<input checked="" type="checkbox"/>	<input checked="" type="checkbox"/>	<input checked="" type="checkbox"/>	
GPS Altitude	<input checked="" type="checkbox"/>	<input checked="" type="checkbox"/>	<input checked="" type="checkbox"/>		

## Explanation of basic concepts

### Sample factor $M_V$

ISTAT M365A/M365B measures all primary quantities with sample frequency which cannot exceed a certain number of samples in a time period. Based on these limitations (128 sample/per at 65Hz) a sample factor is calculated. A sample factor ( $M_V$ ), depending on frequency of a measured signal, defines a number of periods for a measurement calculation and thus a number of harmonics considered in calculations.

### Average interval MP

Due to readability of measurements from communication or LCD (where available), an Average interval (MP) is calculated with regard to the measured signal frequency. The Average interval (see chapter Measurements – Min/Max values) defines refresh rate of displayed measurements based on a sampling factor.

### Sample frequency

ISTAT M365A/M365B measures all primary quantities with a constant sampling rate of 31 kHz (625 sample/per at 50 Hz).

### Average interval

Operation of ISTAT M365A/M365B depends on several Average intervals, which should all be well understood and set to a proper value.

### Average interval for measurements and display

Due to readability of measurements from LCD and communication, an Average interval can be selected from a range of predefined values (from 0.1s to 5 s). The Average interval (see chapter Measurements – Min/Max values) defines refresh rates of displayed measurements.

Alarms response time is influenced by general average interval if their response time setting is set to “Normal response”. If it is set to “Fast response” alarms depend on a single period measurement.

This average interval has no influence on PQ measurements.

### Average interval for min/max values

Min/max values often require special averaging period, which enables or disables detection of short measuring spikes. With this setting it is possible to set averaging from 1 period to 256 periods.

### Average (storage) interval for recorders

This storage interval defines a period for writing data into internal memory. It can be set from 1 min to 60 min. At the end of every interval different types of measured data can be stored into the recorder (see General purpose recorder settings).

## Average (aggregation) interval for PQ parameters

Standard IEC61000-4-30 defines different aggregation intervals and procedures for aggregation of measured PQ parameters.

For each PQ parameter it is possible to set a required aggregation interval. Standard aggregation intervals are:

- 10 periods (12 for 60 Hz system) - for calculations only
- 150 periods (180 for 60 Hz system) - for calculations only
- 3 sec
- 10 sec
- 10 min (also basic time synchronization tick interval)
- 2 h

It is also possible to set other aggregation intervals according to requirements. Additional aggregation intervals are 30 sec, 1 min, 15 min and 1 h.

## Power and energy flow

Figures below show the flow of active power, reactive power and energy for 4u connection.

Display of energy flow direction can be adjusted according to connection and operation requirements by changing the Energy flow direction settings.

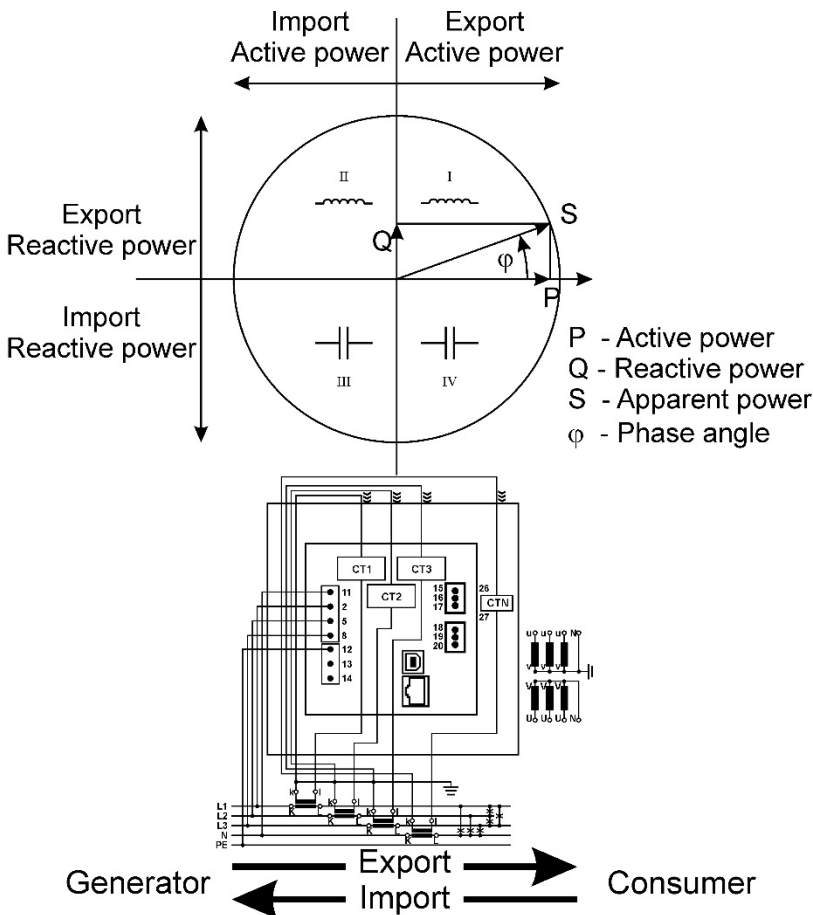

Explanation of energy flow direction

## Calculation and display of measurements

This chapter deals with capture, calculation and display of all supported measurement quantities. Only the most important equations are described; however, all of them are shown in a chapter APPENDIX C: EQUATIONS with additional descriptions and explanations.

### PLEASE NOTE

Calculation and display of measurements depend on the connection used. For more detailed information please see chapter Selection of available quantities.

## Keyboard and LCD (M365B) display presentation

For entering and exiting the measurements display menu, the OK key is used. Measurements are combined in to logical groups named by main measured parameter such as (Voltage, Current...). Within selected group is possible to maneuver with the help of left and right button, between the groups is possible to maneuver with the help of up and down button.

Below is an example for 4u connection mode:

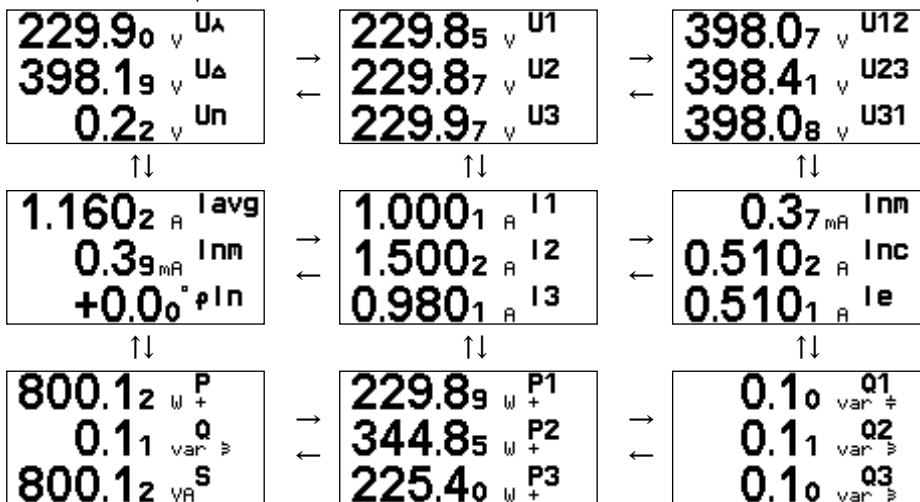

## Keyboard and TFT (M365A) display presentation

For entering the Measurements menu, use DOWN and UP buttons go to Measurements and use SELECT to enter.

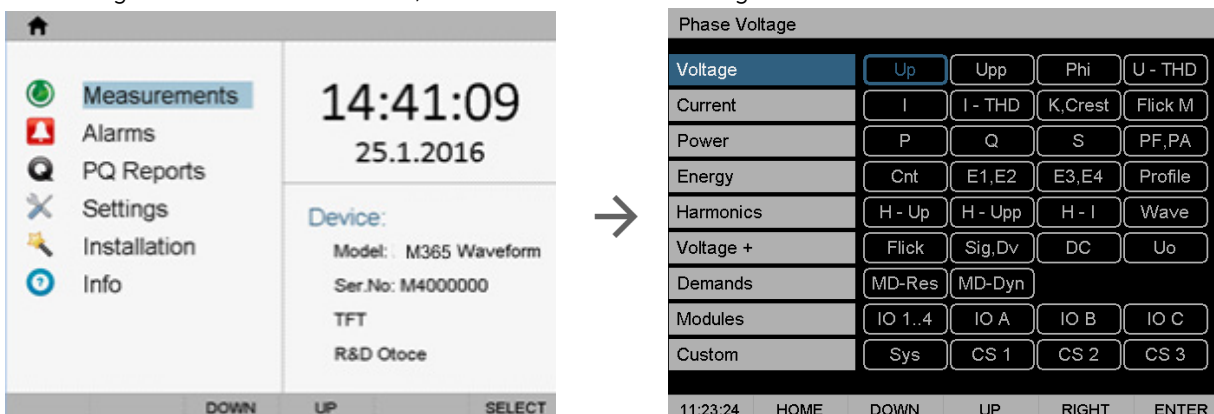

Measurements are divided in to different groups. Use DOWN, UP and RIGHT button to select desired measurements and ENTER to enter:

Phase Voltage

Voltage	Up	Upp	Phi	U - THD
Current	I	I - THD	K.Crest	Flick M
Power	P	Q	S	PF,PA
Energy	Cnt	E1,E2	E3,E4	Profile
Harmonics	H - Up	H - Upp	H - I	Wave
Voltage +	Flick	Sig,Dv	DC	Uo
Demands	MD-Res	MD-Dyn		
Modules	IO 1..4	IO A	IO B	IO C
Custom	Sys	CS 1	CS 2	CS 3

11:23:24 HOME DOWN UP RIGHT ENTER

Enter selected measurement using ENTER

Scroll between different measurement groups using UP/DOWN button

Select specific measurement using RIGHT button

When group of selected measurements is displayed, other, neighbor measurements can be entered directly by pressing button below the measurements description.

To exit measurements display click MENU button.

Below are few examples for 4u connection mode:

Phase Voltage

U1	226.25 v	▲ 235.86 V	▼ 224.43 V
U2	225.03 v	▲ 236.65 V	▼ 224.32 V
U3	224.66 v	▲ 236.35 V	▼ 224.40 V
U~	225.31 v	▲ 236.65 V	▼ 224.40 V
f	49.999 Hz	▲ 50.460 Hz	▼ 49.998 Hz

9:08:43 U - THD I Sys Upp MENU

Phase to phase Voltage

U12	390.21 v	▲ 408.04 V	▼ 390.20 V
U23	390.21 v	▲ 409.67 V	▼ 390.20 V
U31	390.32 v	▲ 390.31 V	▼ 390.31 V
Ung	0.06 v	▲ 0.62 V	▼ 0.06 V
Upp~	390.24 v	▲ 408.09 V	▼ 0.00 V

9:11:06 Up I - THD CS 1 Phi MENU

Phase Angle

Phi U12	120.38 °
Phi U23	119.72 °
Phi U31	119.88 °
Phi Un	0.00 °
Phi In	0.00 °

9:12:55 Upp K.Crest CS 2 U - THD MENU

Current

I1	474.7 mA	▲ 0.476 A	▼ 0.472 A
I2	474.7 mA	▲ 0.477 A	▼ 474.7 mA
I3	474.8 mA	▲ 0.476 A	▼ 474.8 mA
In	0.00 mA	▲ 0.000 A	▼ 0.000 A
I	1424.2 mA	▲ 1431.2 mA	▼ 0.000 mA

9:26:16 K.Crest P Up I - THD MENU

Current THD

THD - I1	0.13 %
THD - I2	0.08 %
THD - I3	0.08 %
TDD - I1	0.01 %
TDD - I2	0.00 %
TDD - I3	0.00 %

9:30:44 I Q Upp K.Crest MENU

K & Crest factor

K-I1	1.00
K-I2	1.00
K-I3	1.00
CrestI1	141.40 %
CrestI2	141.40 %
CrestI3	141.30 %

9:31:24 I - THD S Phi Flick M MENU

Active Power

P1	100.98 w	▲ 105.7 W	▼ 100.12 W
P2	100.21 w	▲ 105.7 W	▼ 100.04 W
P3	100.37 w	▲ 105.51 W	▼ 100.09 W
P	301.58 w	▲ 316.3 W	▼ 301.57 W

9:35:35 PF,PA Cnt I Q MENU

Reactive Power

Q1	36.68 var	▲ 38.1 var	▼ 36.04 var
Q2	36.08 var	▲ 39.1 var	▼ 36.08 var
Q3	36.80 var	▲ 38.66 var	▼ 36.10 var
Q	109.57 var	▲ 115.3 var	▼ 109.55 var

9:36:38 P E1,E2 I - THD S MENU

Apparent Power

S1	106.69 VA	▲ 112.4 VA	▼ 106.53 VA
S2	107.35 VA	▲ 112.6 VA	▼ 106.47 VA
S3	106.84 VA	▲ 112.22 VA	▼ 106.53 VA
S	320.88 VA	▲ 336.6 VA	▼ 320.85 VA

9:37:43 Q E3,E4 K.Crest PF,PA MENU

## Measurements menu organization

Because of different built in display technologies also organization of data presentation on devices is different though both models show the same measurement parameters.

### Measurements menu M365B

Measurement menu on LCD display is organized in two levels. In the first level, set of measured data is selected such as present values, Min/Max values, Alarms... when entered, selected measurements are shown.

Because of display limitation maximum three values are shown at the time (exceptions are Overview display and Custom display 4).

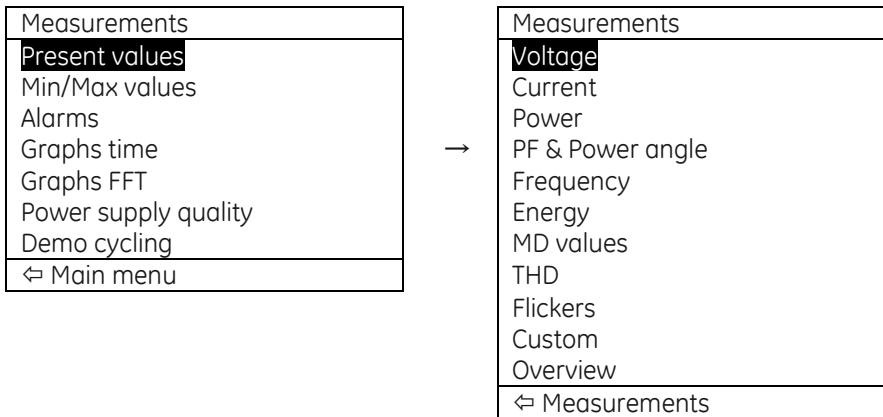

Below is example for Present values > Voltage for 4u connection.

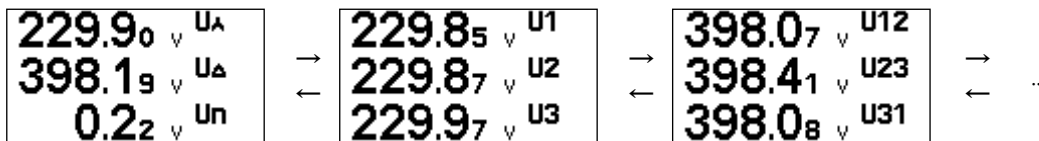

## Measurements menu M365A

On TFT display all measurements options are shown at once in measurement menu. Enter selected measurement using Enter button. Basic differences between LCD and TFT display:

- Alarms and Power Quality information can be accessed directly from the Main menu. More is described later in the following chapters.

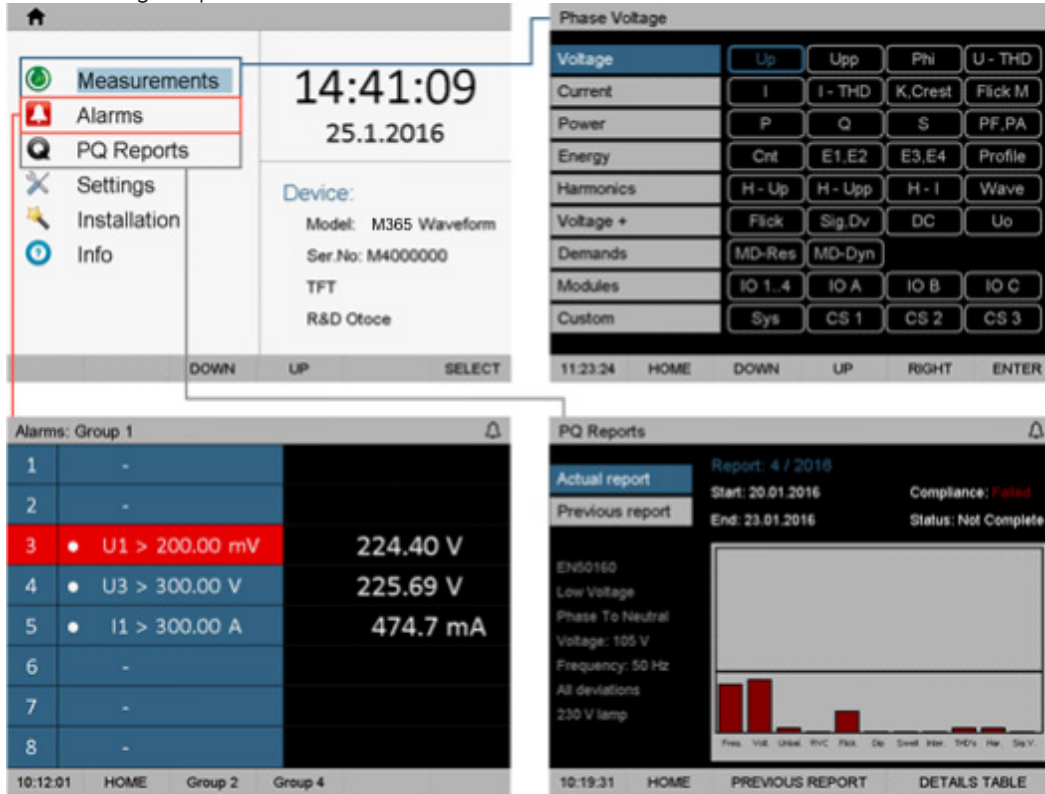

- Min/Max values (where calculated) are presented on the same displays as Present values.

Phase Voltage		
U1	226.25 v	▲ 235.86 V ▼ 224.43 V
U2	225.03 v	▲ 236.65 V ▼ 224.32 V
U3	224.66 v	▲ 236.35 V ▼ 224.40 V
U~	225.31 v	▲ 236.65 V ▼ 224.40 V
f	49.999 Hz	▲ 50.460 Hz ▼ 49.998 Hz

Min/Max values

- Graphical displays are shown in the group Harmonics

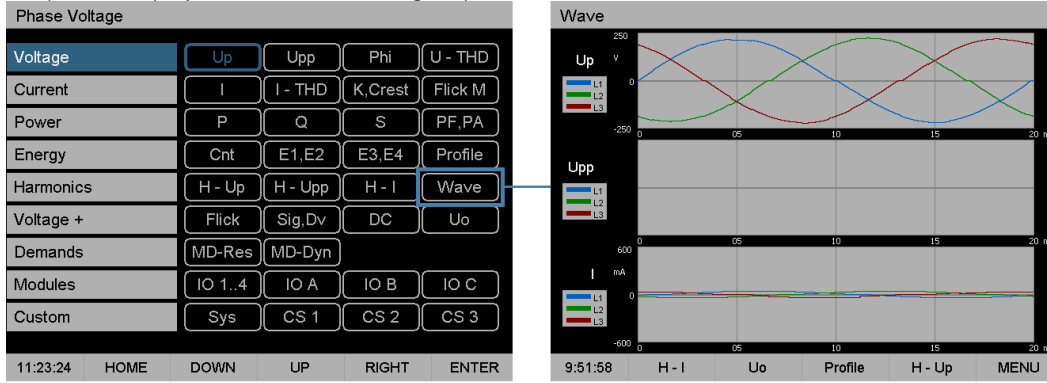

- In group Modules there are added information about the current state of the built in modules

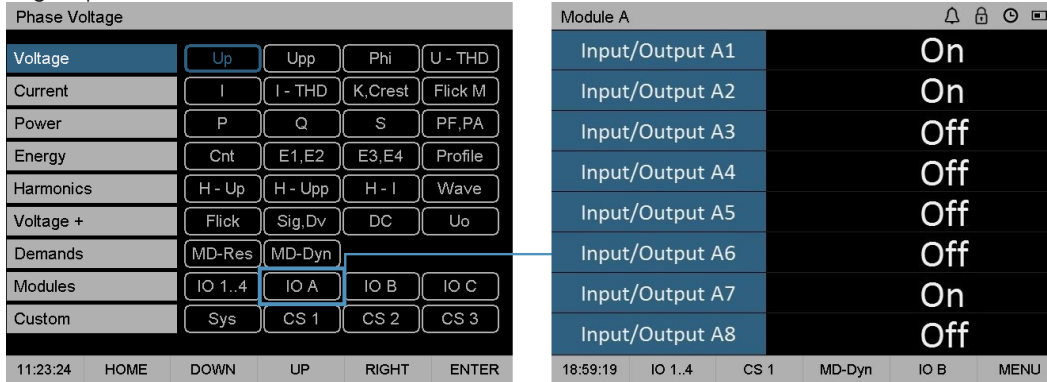

- On the System display in the group Custom, phasor diagram is shown

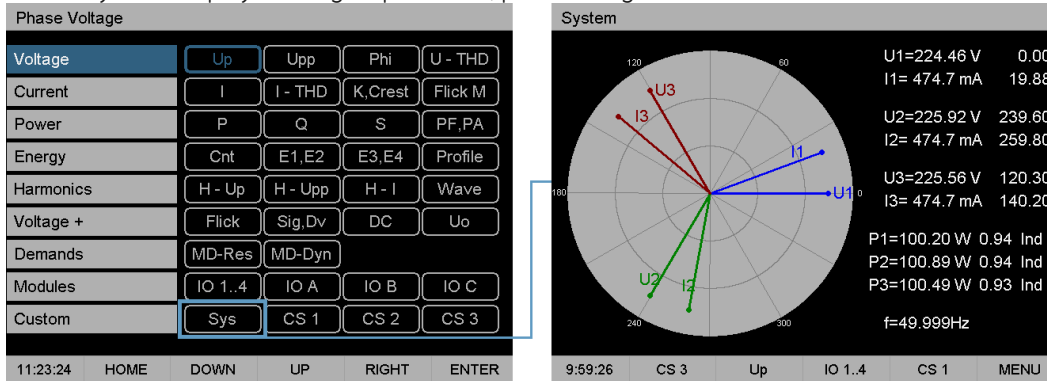

## Present values

### ⚠ PLEASE NOTE

Display of present values depends on connection mode. Therefore display organization slightly differs from one connection mode to another.

## Present values on LCD and TFT display

Organization of measurements on TFT display is, a bit different than on LCD, though basic concept remains the same. Because of physical limitation, LCD display on M365B shows maximum of 3 measured parameters at the time (with some exceptions). TFT on M365A on the other hand has much more possibilities, therefore some data are combined in order to give the user more complex overview over the measured parameter at once.

### ⚠ PLEASE NOTE

Display of present values depends on connection mode. Therefore display organization slightly differs from one connection mode to another.

## Voltage

Voltage related measurements are listed below:

- Real effective (RMS) value of all phase voltages ( $U_1, U_2, U_3$ ), phase-to-phase voltages ( $U_{12}, U_{23}, U_{31}$ ) and neutral to earth voltage ( $U_n$ ).
- Average phase voltage ( $U_\lambda$ ) and average phase-to-phase voltage ( $U_\Delta$ )
- Negative and zero sequence unbalance ratio ( $U_u, U_0$ )
- Phase and phase-to-phase voltage angles ( $\varphi_{12}, \varphi_{23}, \varphi_{31}$ )
- Signaling phase and phase-to-phase voltages ( $U_{S12}, U_{S23}, U_{S31}$ )
- DC component of phase and phase-to-phase voltages including neutral line ( $=U_1, =U_2, =U_3, =U_{12}, =U_{23}, =U_{31}$ )

$$U_f = \sqrt{\frac{\sum_{n=1}^N u_n^2}{N}}$$

$$U_{xy} = \sqrt{\frac{\sum_{n=1}^N (u_{xn} - u_{yn})^2}{N}}$$

All voltage measurements are available through communication as well as on standard or customized displays. The device gives out a warning if input signal is too large. In this case when signal representation is not correct the indicator ⚠ is shown above the parameter unit (see example from Custom screen set to show  $U_1, I_1$  and  $P_1$  below):

999.65	⚠	U1
	V	
4.9989	⚠	I1
	A	
4327.7	⚠	P1
	W	

## Current

ISTAT M365A/M365B measures:

- real effective (RMS) value of phase currents and neutral measured current ( $I_{nm}$ ), connected to current inputs
- Neutral calculated current ( $I_{nc}$ ), Neutral error current ( $I_e = |I_{nm} - I_{nc}|$ ),
- Phase angle between Neutral voltage and Neutral Current ( $\varphi_{in}$ ), Average current ( $I_a$ ) and a sum of all phase currents ( $I_t$ )
- Crest factor of phase currents (CRI1-3)

$$I_{RMS} = \sqrt{\frac{\sum_{n=1}^N i_n^2}{N}}$$

All current measurements are available on communication as well as standard and customized displays on LCD.

## Active, reactive and apparent power

Active power is calculated from instantaneous phase voltages and currents. All measurements are seen on communication or are displayed on LCD. For more detailed information about calculation see chapter APPENDIX C: EQUATIONS.

There are two different methods of calculating reactive power. See chapter Reactive power & energy calculation. ISTAT M365A/M365B issues a warning if input signal is too large. In this case signal representation is not correct. Indicator ⚡ is shown above the parameter unit:

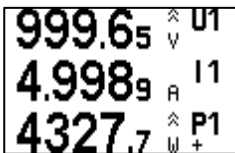

## Power factor and power angle

Power factor is presented in two forms:

PF or distortion power factor is calculated as the quotient of active and apparent power for each phase separately and total power angle. It is called distortion power factor since true (distorted) signals are using in equation (all equations are presented in chapter APPENDIX C: EQUATIONS). A symbol for a coil (positive sign) represents inductive load and a symbol for a capacitor (negative sign) represents capacitive load.

dPF or displacement power factor represents TRUE displacement power factor, which is based on fundamental active and apparent power without influence of harmonic components. It represents the angle between first (base) voltage harmonic and first (base) current harmonic for each individual phase.

For correct display of PF via analogue output and application of the alarm, ePF (extended power factor) is applied. It illustrates power factor with one value as described in the table below. For a display on LCD both of them have equal display function: between -1 and +1 with the icon for inductive or capacitive load.

Presentation of extended PF (ePF)

Load	C	→		←	L
Angle [°]	-180	-90	0	+90	+180 (179.99)
PF	-1	0	1	0	-1
ePF	-1	0	1	2	3

Example of analogue output for PF and ePF:

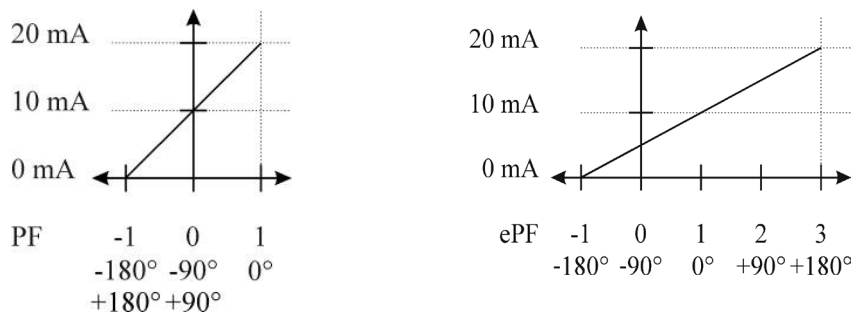

## Frequency

Network frequency is calculated from time periods of measured voltage. Instrument uses synchronization method, which is highly immune to harmonic disturbances.

ISTAT M365A/M365B always synchronizes to a phase voltage  $U1$ . If signal on that phase is too low it (re)synchronizes to the next phase. If all phase voltages are low (e.g. short circuit) device synchronizes to phase currents. If there is no signal present on any voltage or current channels, the device shows a frequency of 0 Hz.

Additionally, the frequency with 10-second averaging interval is displayed.

## Energy counters

Three different variants of displaying Energy counters are available:

- by individual counter,
- by tariffs for each counter separately and
- energy cost by counter

At a display of measured counter by tariffs, the sum in the upper line depends on the tariffs set in the instrument.

There are two different methods of calculating reactive energy. See chapter Reactive power & energy calculation.

Additional information, how to set and define a counter quantity is explained in chapter Settings – Energy.

## MD values

MD (Maximum Demand) values and time stamp of occurrence are shown for:

- Three phase currents
- Active powers (import and export)
- Reactive power (ind. and cap.)
- Apparent power

Dynamic demands are continuously calculated according to set time constants and other parameters.

Reset demands are max. values of Dynamic demands since last reset.

## Harmonic distortion

ISTAT M365A/M365B calculates different harmonic distortion parameters:

- THD is calculated for phase currents, phase voltages and phase-to-phase voltages and is expressed as percent of high harmonic components regarding to fundamental harmonic

ISTAT M365A/M365B uses a measuring technique of real effective (RMS) value that calculates exact measurements with the presence of high harmonics up to 63rd harmonic. Please see Settings – Real time synchronization source – Harmonic calculation for more information on harmonic calculation.

## Harmonic distortion parameters

ISTAT M365A/M365B calculates different harmonic distortion parameters:

- THD is calculated for phase currents, phase voltages and phase-to-phase voltages and is expressed as percent of high harmonic components regarding to fundamental harmonic
- TDD is calculated for phase currents
- K-factor is calculated for phase currents

ISTAT M365A/M365B uses the measuring technique of real effective (RMS) value that assures exact measurements with the presence of high harmonics up to 63rd harmonic. Please see Settings – Real time synchronization source – Harmonic calculation for more information on harmonic calculation.

## Flicker evaluation

Flickers are one of most important PQ parameters directly (through light flickering) influencing human feeling.

Flickers are measured in statistically evaluated according to relevant standard IEC 61000-4-15.

For basic flicker measurements on all three voltage phases 1200 readings per second are used. Instantaneous flicker sensation decimates this sampling rate 8 times (150 instantaneous flicker calculations per second) and uses approximately 3s averaging time.

With further statistical evaluation short term and long term flickers are calculated.

**$P_{i-3}$**  represents instantaneous flicker and is averaged and refreshed every 3 sec.  $P_i$  is averaged from 500 instantaneous flicker calculations.

**$P_{im1-3}$**  represents max. value of instantaneous flicker  $P_i$  within 3 sec flicker averaging interval and is refreshed every 3 sec. This value is displayed only on display. It is not available on communication.

**$P_{st1-3}$**  represents 10 min statistical evaluation of instantaneous flicker and is refresh every round 10 minutes (x:00, x:10, x:20...)

**$P_{lt1-3}$**  represents 2 h statistical evaluation of short-time flicker  $P_{st}$  and is refreshed every even 2 hours (0:00, 2:00, 4:00...)

Until the flicker value is calculated the symbol – is displayed.

## Flicker

Measurements of current Short term and Long term flickers for phase or phase-to-phase voltage (depending on mode of connection). Until the flicker value is calculated the symbol “-.-” is displayed.

## Customized screens

On Power Quality Analyzer **M365B** with LCD display, four different customized screens can be set. First three screens shows three different user defined parameters whereas the fourth screen displays five different parameters as a combination of the three parameters of the first screen and the first two parameters of the second screen.

On Power Quality Analyzer **M365A** with TFT display, three different customized screens can be set. For each screen, eight different parameters can be set.

### PLEASE NOTE

When, due to mode of connection, an unsupported measurement is selected for the customized screen an undefined value is displayed.

### Example: M365B on 4u connection:



Main menu ⇒ Measurements ⇒ Present values ⇒ Overview OK / ⇒

U <sub>A</sub>	229.89	V	P	+800.11
I <sub>1</sub>	229.85	V	P1	+229.88
Q <sub>2</sub>	229.86	V	P2	+344.84
Q <sub>3</sub>	229.97	V	P3	+225.39
I <sub>A</sub>	1.1602	A	Q	+0.11
I <sub>1</sub>	1.0001	A	Q1	-0.10
I <sub>2</sub>	1.5002	A	Q2	+0.11
I <sub>3</sub>	0.9801	A	Q3	+0.10



U <sub>Δ</sub>	398.19	V	52.999	Hz
I <sub>2</sub>	398.07	V	φ	-119.98°
I <sub>3</sub>	398.40	V	φ	-120.11°
Q <sub>1</sub>	398.08	V	φ	-119.94°
PF	+1.000L	φ	+0.00°	
PF1	+1.000C	φ	-0.03°	
PF2	+1.000L	φ	+0.01°	
PF3	+1.000L	φ	+0.02°	



P+	=793.76	39.995kW
P-	= 0.000	39.995kW
Q+	= 0.343	39.995kvar
Q-	= 0.000	39.995kvar
S	=795.14	39.995kVA
I <sub>1</sub>	=0.9927	19.998 A
I <sub>2</sub>	=1.4893	19.998 A
I <sub>3</sub>	=0.9729	19.998 A

## Min/Max values

All Min/Max values are displayed similar as Present values.

### PLEASE NOTE

On Power Quality Analyzer M365A Min/Max values are displayed on the same screen as Present values.

## Average interval for min/max values

Min/max values often require special averaging period, which enables or disables detection of short measuring spikes. With this setting is possible to set averaging from 1 period to 256 periods.

## Display of min/max values on M365B

Present values are displayed with larger font in the middle of the screen, while minimal and maximal values are displayed in smaller font above and below the present values.

### Example of Min/Max screens:

Phase Voltage	Current	Active Power
Max <b>231.63</b> V	Max <b>80.15</b> A	Max <b>+42.06</b> kW
<b>224.33</b> V U1	<b>19.936</b> A I1	<b>19.041</b> kW P
Min <b>123.57</b> V	Min <b>0.05</b> A	Min <b>+0.00</b> kW

## Display of min/max values on M365A

Present values are displayed with larger font in the middle column, while minimal and maximal values are displayed in smaller font in the right column, indicated with arrows (down for minimal, up for maximal).

Example of Min/Max values on Power Quality Analyzer M365A:

Phase Voltage		
U1	<b>226.25</b> V	▲ 235.86 V ▼ 224.43 V
U2	<b>225.03</b> V	▲ 236.65 V ▼ 224.32 V
U3	<b>224.66</b> V	▲ 236.35 V ▼ 224.40 V
U~	<b>225.31</b> V	▲ 236.65 V ▼ 224.40 V
f	<b>49.999</b> Hz	▲ 50.460 Hz ▼ 49.998 Hz

Min/Max values

## Display of min/max values – QDSP2.1 software

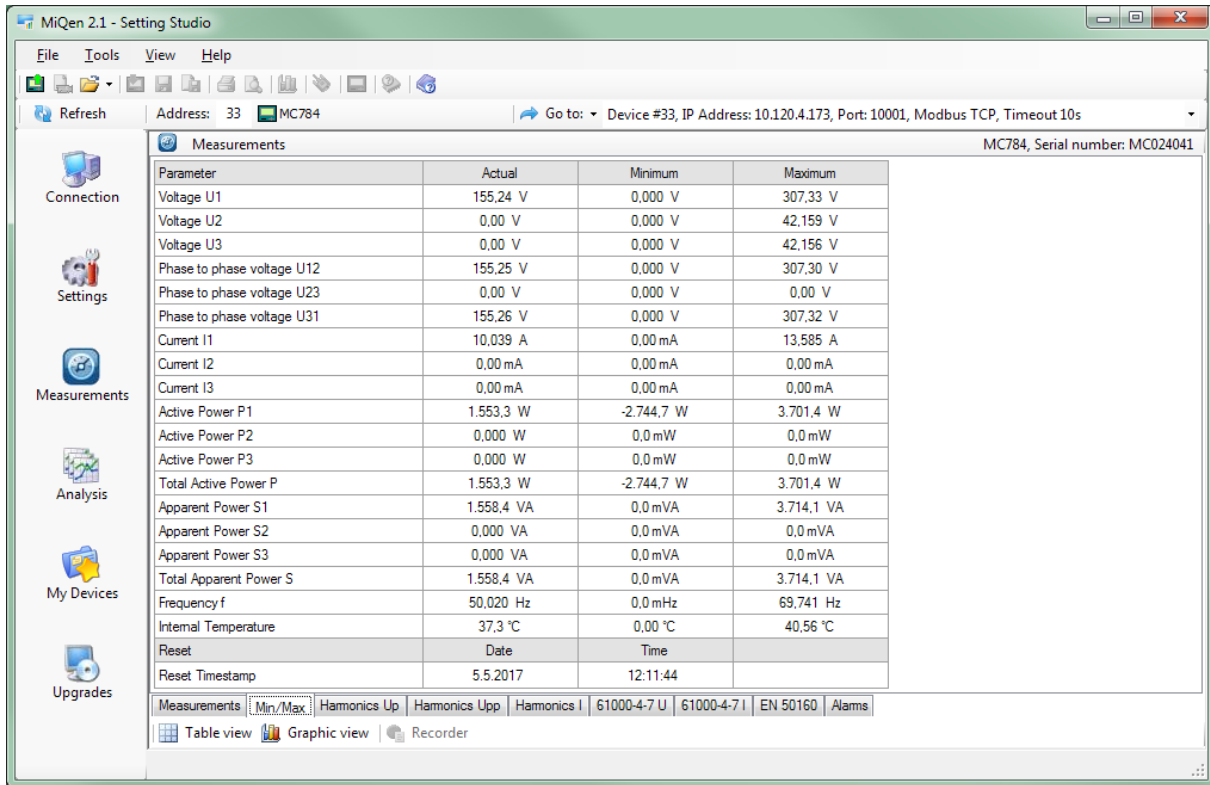

Presentation of min/max values – Table view

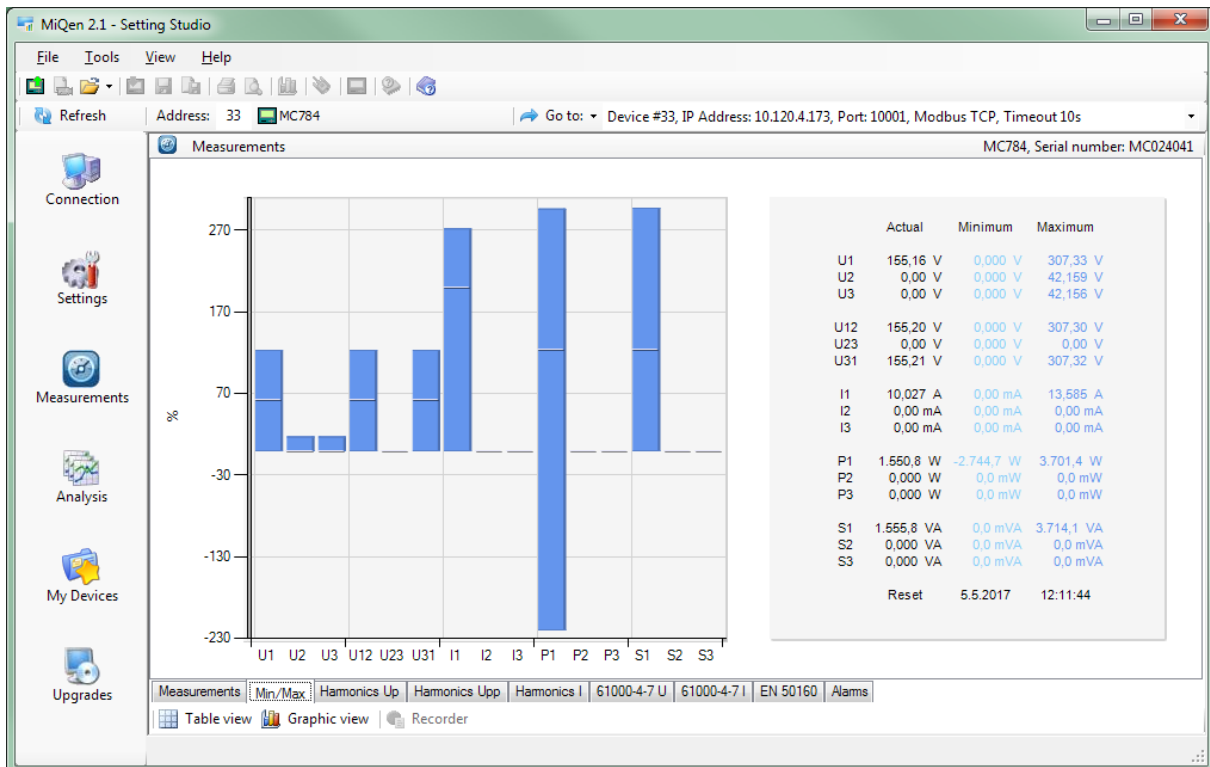

Presentation of min/max values – Graphic view

In graphical presentation of min/max values relative values are depicted. Base value for relative representation is defined in general settings/Connection mode/used voltage, current range. For phase voltages and for phase-to-phase voltages the same value is used.

## Alarms

Alarms are an important feature for notifying exceeded user predefined values. Not only for visualization and recording certain events with the exact time stamp. Alarms can be connected to digital/alarm outputs to trigger different processes (switch closures, line breaking, motors start or stop...).

It is also very convenient to monitor the alarms history. This is enabled on display and even better on communication by using the QDSP2.1 setting and analysis software.

Alarm menu on display enables surveying the state of ongoing and past alarms.

### M365B

In the alarm menu, groups of alarms with states of individual alarms are displayed. Also connected alarm outputs are displayed in the bottom line. If displayed alarm output is highlighted it means it is active (relay closed). For each active alarm a number of alarms is written in a certain group at a certain character location e.g.: Group 1: 1<<45<<8.. Dot stands for alarm not active.

In example below there was 1 alarm, which happened under condition defined in Group1/Alarm1 (middle picture). Condition for that alarm was  $U1 > 250.00\text{ V}$  (right picture). Alarm activated Relay output 2 (middle picture, highlighted Out2).

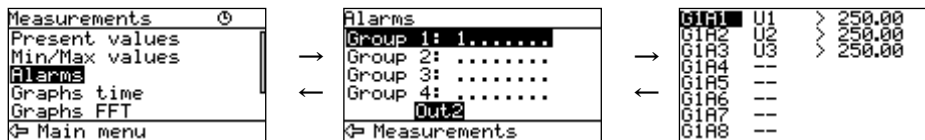

M365A

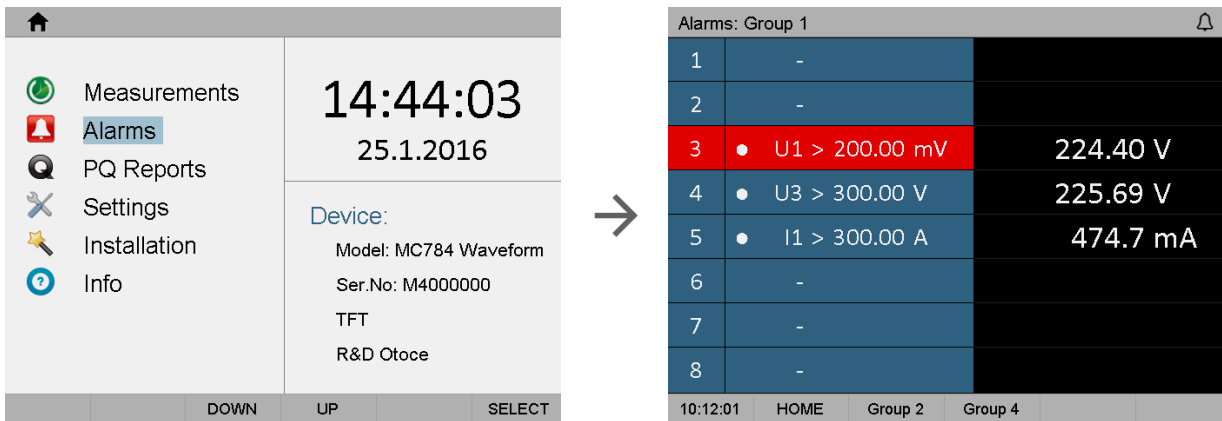

Alarm menu can be accessed directly from Main menu. In the alarm menu, groups of alarms with states of individual alarms are displayed. If displayed alarm output is highlighted (red) it means it is active. Switch between alarm groups with left/right button.

Example:

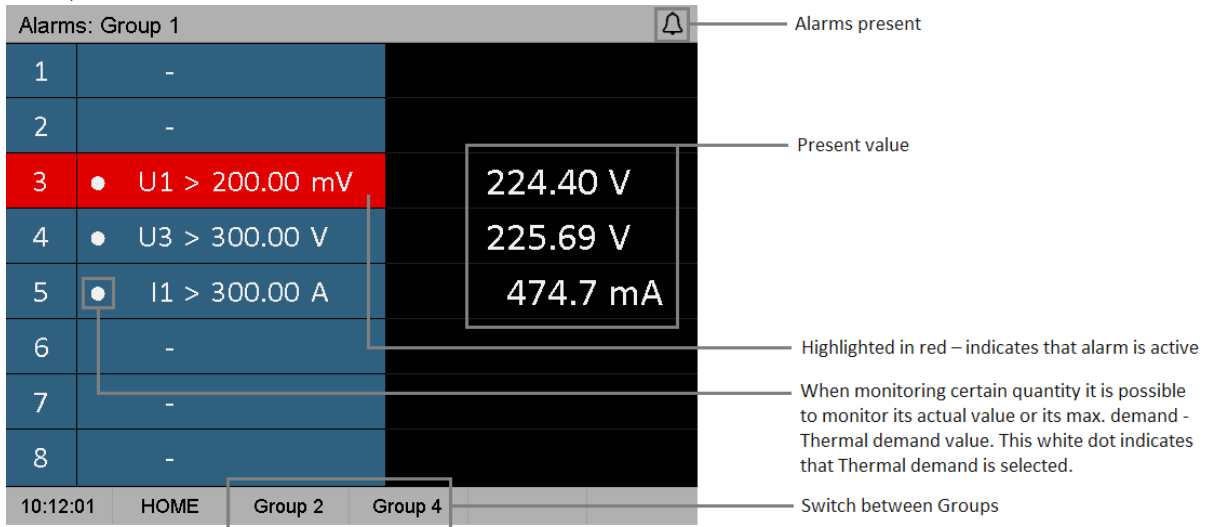

## Survey of alarms

In a detailed survey alarms are collected in groups. A number of a group and alarm is stated in the first column, a measurement designation in the second, and a condition for alarm in the third one. An active alarm is also marked.

Alarm group	State	Events
<b>Alarm group 1</b>		
1: U1 < 184,0 V	Off	3
2: U2 < 165,6 V	Off	3
3: U3 < 184,0 V	Off	3
4: -		
5: -		
6: -		
7: -		
8: -		
<b>Alarm group 2</b>		
9: I1 < 5,00 A	Alarm On	1
10: I2 < 5,00 A	Alarm On	1
11: I3 < 5,00 A	Alarm On	1
12: -		
13: -		
14: -		
15: -		
16: -		
<b>Alarm group 3</b>		
17: U1 < 184,0 V	Off	3
18: U2 < 165,6 V	Off	3
19: U3 < 184,0 V	Off	3
20: -		
21: -		
22: -		

Presentation of alarms – Table view

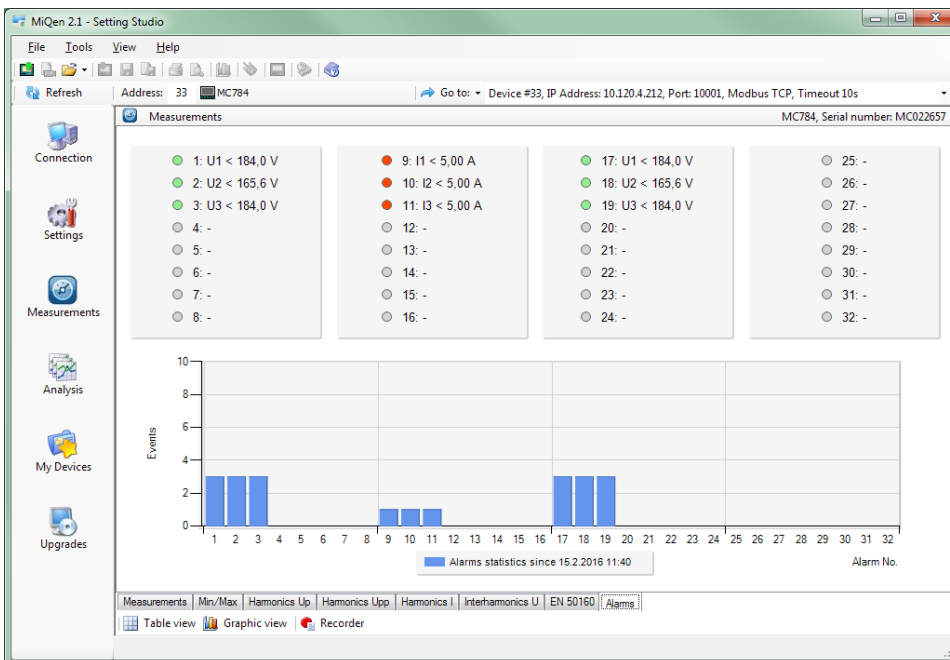

Presentation of alarms – Graphic view

In QDSP2.1 software all alarms are presented in tabular and graphical form as shown in figures above. For each alarm the following information is shown:

- Group association
- Group Alarm conditions
- Momentary alarm state
- Number of alarm events since last reset

## Demo cycling

Regarding the period that is defined in settings, measurement screen cycling is started until any key is pressed.

---

### PLEASE NOTE

Power Quality Analyzer M365A currently doesn't support this feature.

---

## Harmonic analysis

Harmonic analysis is an important part of PQ monitoring. Frequency converters, inverters, electronic motor drives, LED, halogen and other modern lamps. All listed above may cause harmonic distortion of supply voltage and can influence other sensitive equipment to malfunction or even damage.

In particular vulnerable are distribution level compensation devices whose capacitor banks act like a drain for higher harmonics and amplify their influence. Higher harmonic currents flowing through capacitors can cause overheating and by that shortening their lifetime or even explosions.

Monitoring harmonic distortion is therefore important not only to prevent malfunction of household equipment and to prolong operation of motors but also to prevent serious damage to distribution equipment and to people working close to compensation devices.

Due to importance of harmonic analysis, a special standard IEC 61000-4-7 defines methods for measurement and calculation of harmonic parameters.

ISTAT M365A/M365B measures harmonics up to 63<sup>rd</sup> and evaluates the following harmonic parameters:

- Phase Voltage/Current harmonic signals and THD  $U_{P-N}$
- Phase-to-phase Voltage/Current harmonic signals and THD  $U_{P-P}$
- THD  $U_{P-N}$ , THD  $U_{P-P}$ , THD  $I_{P-N}$  and THD  $I_{P-P}$
- TDD total demand distortion for phase currents
- CREST factor for proper dimensioning of connected equipment
- K factor for proper dimensioning of power transformers
- Inter-harmonics (10 user defined inter-harmonic values)
- Signaling voltage (monitoring ripple control signal)

---

### PLEASE NOTE

Some of the above listed measurements are only available on communication.

---

All of the listed harmonic parameters can be monitored online, stored in internal memory and compared against alarm condition threshold limit.

The latter is in combination with alarm relay output suitable for notification and/or automatic disconnection of compensation devices, when too much harmonics could threaten capacitors.

## Display of harmonic parameters

### M365B

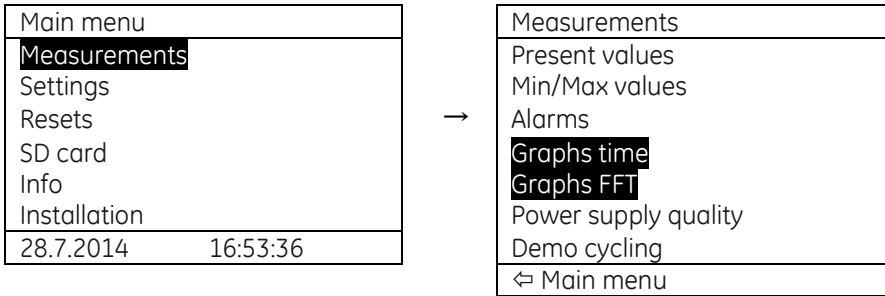

Harmonic parameters can be displayed on the device LCD in graphical form and as a table form in QDSP2.1 software:  
LCD graphical presentation:

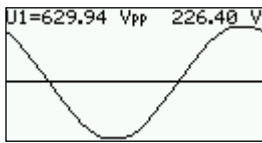

Display of a Phase Voltage in time space diagram. Displayed are also peak value of monitored phase voltage and its RMS value. Similar display is also for phase-to-phase voltages.

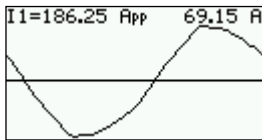

Display of a Current in time space diagram. Displayed are also peak value of monitored current and its RMS value

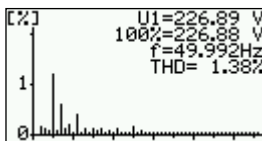

Display of a Phase Voltage in frequency space diagram. Displayed are also RMS value, unit value (100%), system frequency and THD value. Similar display is also for phase-to-phase voltages.

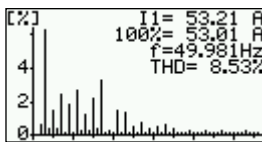

Display of a Current in frequency space diagram. Displayed are also RMS value, unit value (100%), system frequency and THD value.

### M365A

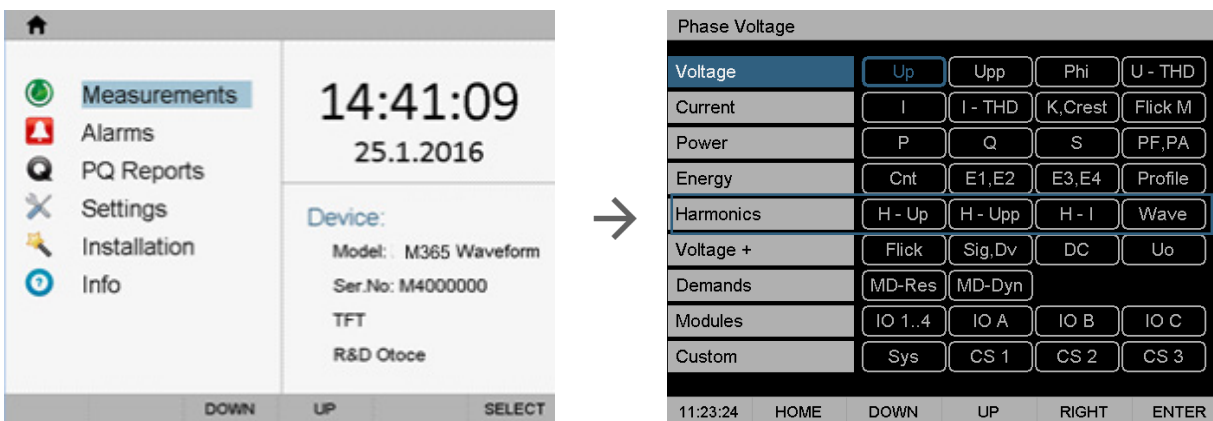

Harmonic parameters can be displayed on the device TFT display in graphical form and as a table form in QDSP2.1 software:

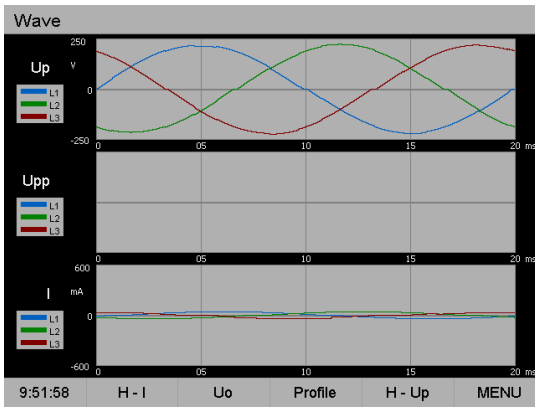

Display of a Phase Voltage, Phase to Phase Voltage and Current in time space diagram.

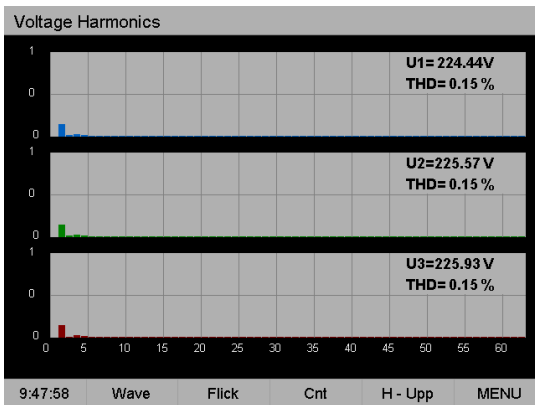

Display of a Phase Voltage in frequency space diagram. Displayed are also RMS value and THD value.

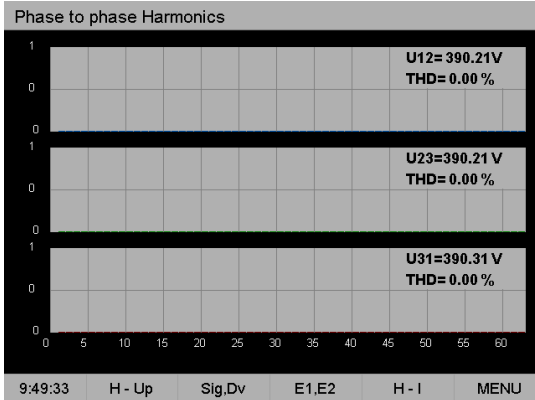

Display of a Phase to Phase Voltage in frequency space diagram. Displayed are also RMS value and THD value.

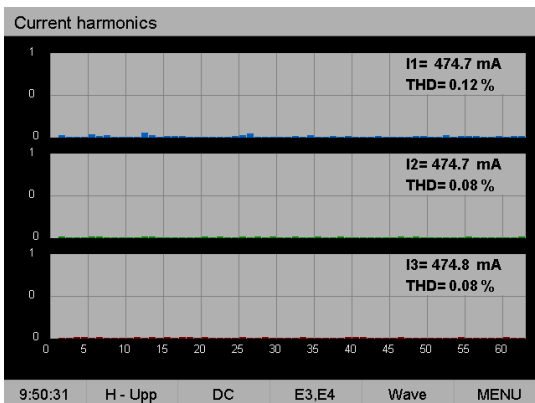

Display of a Current in frequency space diagram. Displayed are also RMS value and THD value.

More information about harmonic parameters, especially individual harmonic values, can be obtained when the device is connected through communication by using the QDSP2.1 software.

Representation of individual harmonics in consists of:

- Absolute value
- Relative value
- Phase angle between base and observed harmonic

### PLEASE NOTE

Relative value can be calculated as a percentage of the base unit or as a percentage of the RMS value. Setting of this relative factor is available under General settings (see Harmonic calculation setting).

## Harmonic analysis – QDSP2.1

Measurements	L1	L2	L3
THD-Up	1.37 %	1.37 %	1.37 %
Base	226.58 V	226.60 V	226.61 V
1. Harmonic	100.02 %	99.97 %	99.97 %
1. Harmonic - Absolute value	226.63 V	226.53 V	226.54 V
1. Harmonic - Phase angle	0.00 °	0.00 °	0.00 °
2. Harmonic	0.03 %	0.03 %	0.03 %
2. Harmonic - Absolute value	0.07 V	0.07 V	0.07 V
2. Harmonic - Phase angle	68.88 °	15.64 °	71.93 °
3. Harmonic	0.71 %	0.72 %	0.72 %
3. Harmonic - Absolute value	1.61 V	1.63 V	1.63 V
3. Harmonic - Phase angle	35.48 °	35.07 °	37.49 °
4. Harmonic	0.01 %	0.02 %	0.02 %
4. Harmonic - Absolute value	0.02 V	0.05 V	0.05 V
4. Harmonic - Phase angle	-13.49 °	-13.73 °	57.79 °
5. Harmonic	0.85 %	0.86 %	0.86 %
5. Harmonic - Absolute value	1.93 V	1.95 V	1.95 V
5. Harmonic - Phase angle	-142.01 °	-140.22 °	-140.51 °
6. Harmonic	0.01 %	0.00 %	0.00 %
6. Harmonic - Absolute value	0.02 V	0.00 V	0.00 V
6. Harmonic - Phase angle	-69.30 °	-88.09 °	-24.73 °
7. Harmonic	0.45 %	0.43 %	0.43 %
7. Harmonic - Absolute value	1.02 V	0.97 V	0.97 V
7. Harmonic - Phase angle	-137.05 °	-134.98 °	-138.39 °
8. Harmonic	0.00 %	0.00 %	0.00 %
8. Harmonic - Absolute value	0.00 V	0.00 V	0.00 V
8. Harmonic - Phase angle	63.02 °	152.54 °	-27.55 °
9. Harmonic	0.26 %	0.27 %	0.27 %

Presentation of phase voltage harmonic components – Table view

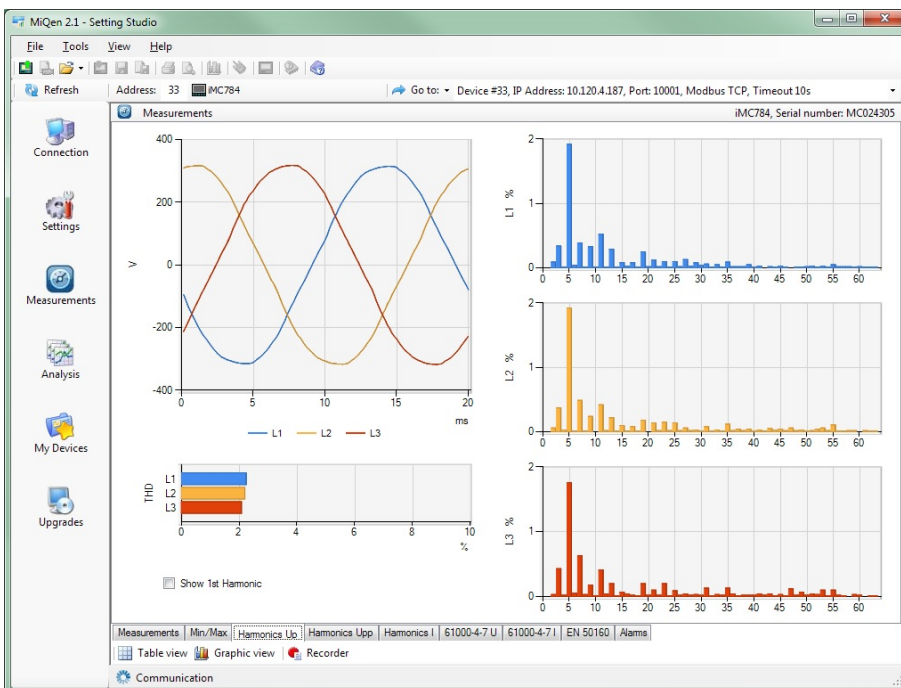

Presentation of phase voltage harmonic components – Graphic view

**PLEASE NOTE**

According to the IEC 61000-4-7 standard that defines methods for calculation of harmonic parameters; harmonic values and inter-harmonic values do not represent signal magnitude at the exact harmonic frequency but weighted sum of centered (harmonic) values and its sidebands. More information on this can be found in the mentioned standard.

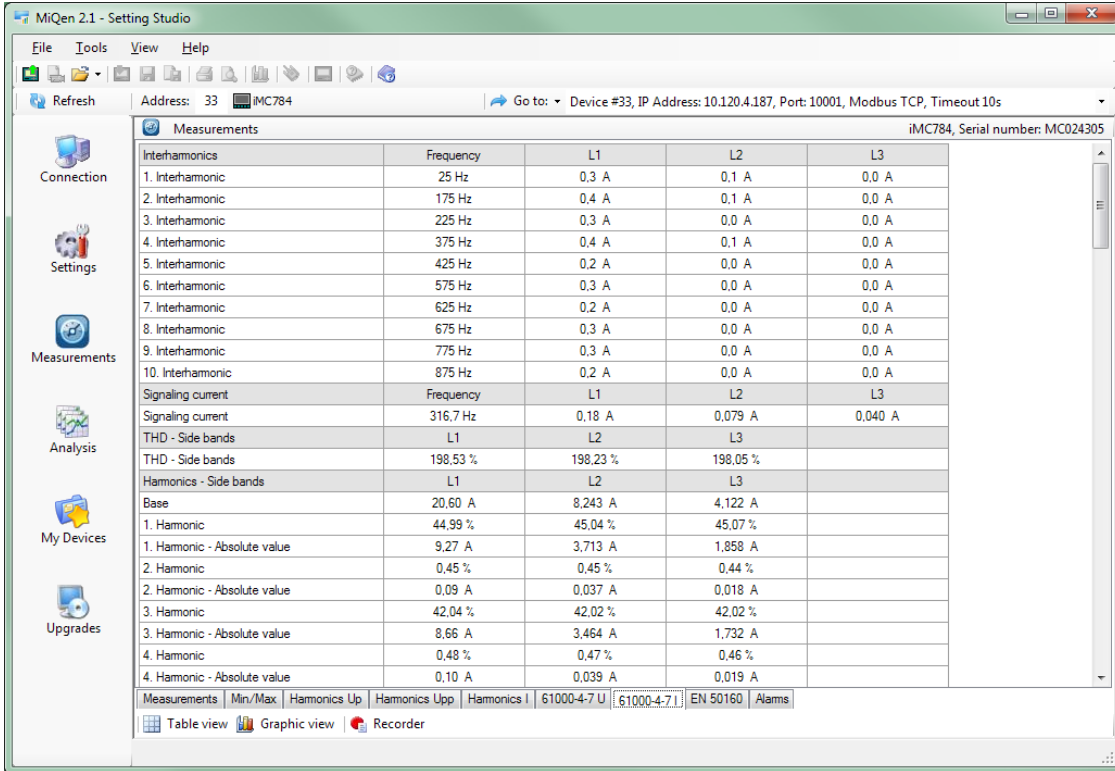

Presentation of 10 phase voltage inter-harmonic components – Table view

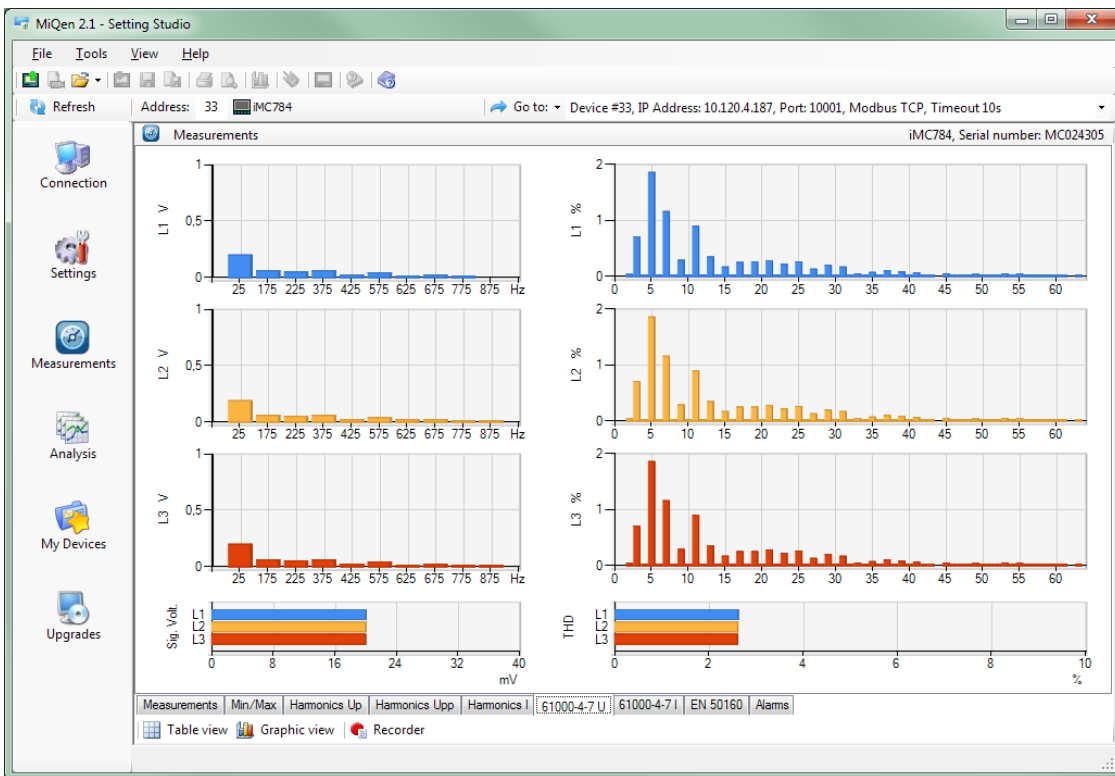

Presentation of phase voltage inter-harmonic component – Graphic view

## PQ Analysis

PQ analysis is a core functionality of the ISTAT M365A/M365B. PQ (Power Quality) is a very common and well understood expression. However it is not exactly in accordance with its actual meaning.

PQ analysis actually deals with Quality of Supply Voltage. Supply Voltage is a quantity for quality of which utility companies are responsible. It influences the behavior of connected apparatus and devices.

Current and power on the other hand are the consequence of different loads and hence the responsibility of consumers. With proper filtering load influence can be restricted within consumer internal network or at most within single feeder while poor supply voltage quality influences a much wider area.

Therefore indices of supply voltage (alias PQ) are limited to anomalies connected only to supply voltage:

Power Quality indices as defined by EN 50160

Phenomena	PQ Parameters
Frequency variations	Frequency distortion
Voltage variations	Voltage fluctuation Voltage unbalance
Voltage changes	Rapid voltage changes Flicker
Voltage events	Voltage dips Voltage interruptions Voltage swells
Harmonics & THD	THD Harmonics Inter-harmonics Signaling voltage

For evaluation of voltage quality the device can store main characteristics in the internal memory. The reports are made on the basis of stored data. Data of the last 300 weeks and up to 170,000 variations of the measured quantities from the standard values are stored in the report, which enables detection of anomalies in the network.

QDSP2.1 software offers a complete survey of reports with a detailed survey of individual measured quantities and anomalies. A survey of compliance of individual measured quantities in previous and actual monitored periods is possible.

### Online monitoring

When all PQ parameters are set and analysis is enabled (information about settings for PQ analysis can be found in a chapter *Conformity of PQ according to EN 50160*) PQ starts with defined date and starts issuing weekly reports (if monitoring period setting is set to one week).

QDSP2.1 software enables monitoring state of actual period and of previous monitoring period. Both periods can be overviewed on the device display just as well.

**M365B**

Example of a PQ report for an actual period is generated on device display. More detailed information about PQ is available through communication.

```
Actual period
Start   : 05.01.2013
End     : 11.01.2013
Status  : Not compl.
Compila.: X
Report:  2/2013
```

Basic information about actual monitoring period. The period here is not completed and currently not in compliance with EN 50160.

```
Actual period
Frequency 1 : ✓
Frequency 2 : X
Unbalance   : ✓
Voltage 1   : ✓
Voltage 2   : ✓
Report:     2/2013
```

Display of current status of PQ parameters. Some (Frequency 2) are currently not in compliance with EN 50160.

```
Actual period
THD        : ✓
Harmonics  : ✓
Short flickers : ✓
Long flickers : X
Rapid V. chg. : ✓
Report:     2/2013
```

Display of current status of PQ parameters. Some (Long flickers) are currently not in compliance with EN 50160.

```
Actual period
Overvoltages : ✓
Dips         : ✓
Short inter. : ✓
Long inter.  : ✓
Signalling v.: ✓
Report:      2/2013
```

Display of current status of PQ parameters. All are in compliance with EN 50160.

### M365A

Example of a PQ report for an actual period is generated on device display. More detailed information about PQ is available through communication.

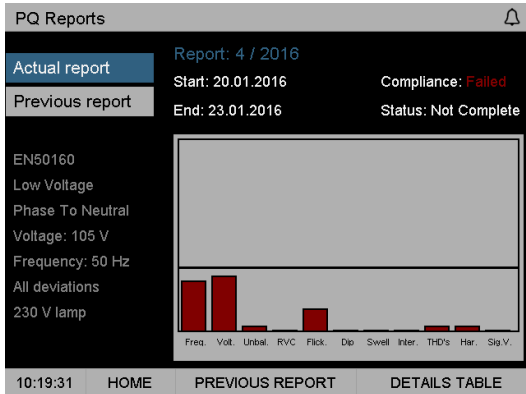

Basic information about actual monitoring period. The period here is not completed and currently not in compliance with EN 50160

Report: 4 / 2016

Parameter	Comp.	L1(System)	L2	L3	Multi phase
Frequency Variations 1	Failed	24.69 %	-	-	-
Frequency Variations 2	Failed	24.69 %	-	-	-
Voltage Variations 1	Failed	16.22 %	16.22 %	16.22 %	-
Voltage Variations 2	Failed	16.22 %	16.22 %	16.22 %	-
Voltage Unbalances	Failed	94.59 %	-	-	-
Rapid Voltage Changes	-	0	0	0	0
Flickers Pst	-	91.89 %	91.89 %	91.89 %	-
Flickers Plt	Failed	67.57 %	67.57 %	67.57 %	-
Voltage Dips	-	4 / 4	6 / 6	4 / 4	10 / 10
Voltage Swells	-	7 / 7	5 / 5	4 / 4	2 / 2
Short Interruptions	-	1 / 1	1 / 1	2 / 2	1 / 1
Long Interruptions	-	0 / 0	0 / 0	0 / 0	0 / 0
THD's	Failed	94.59 %	94.59 %	94.59 %	-
Harmonics	Failed	94.59 %	94.59 %	94.59 %	-
Signaling Voltage	Ok	100.00 %	100.00 %	100.00 %	-

10:22:33 | BACK | PREVIOUS REPORT

Display of current status of PQ parameters for actual monitoring period. Some are currently not in compliance with EN 50160

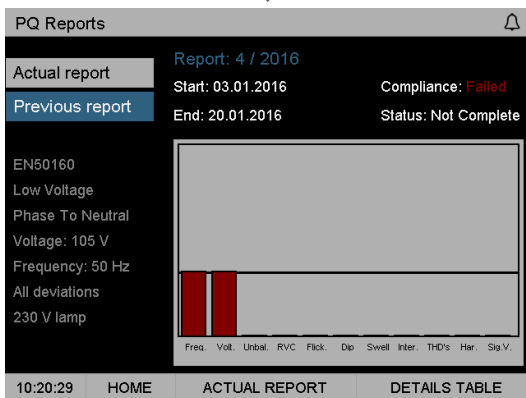

Basic information about previous monitoring period. The period here is not completed and currently not in compliance with EN 50160

Report: 4 / 2016

Parameter	Comp.	L1(System)	L2	L3	Multi phase
Frequency Variations 1	Failed	0.00 %	-	-	-
Frequency Variations 2	Failed	0.00 %	-	-	-
Voltage Variations 1	Failed	0.00 %	0.00 %	0.00 %	-
Voltage Variations 2	Failed	0.00 %	0.00 %	0.00 %	-
Voltage Unbalances	Ok	100.00 %	-	-	-
Rapid Voltage Changes	-	0	0	0	0
Flickers Pst	-	100.00 %	100.00 %	100.00 %	-
Flickers Plt	Ok	100.00 %	100.00 %	100.00 %	-
Voltage Dips	-	0 / 0	0 / 0	0 / 0	0 / 0
Voltage Swells	-	0 / 0	0 / 0	0 / 0	0 / 0
Short Interruptions	-	0 / 0	0 / 0	0 / 0	0 / 0
Long Interruptions	-	0 / 0	0 / 0	0 / 0	0 / 0
THD's	Ok	100.00 %	100.00 %	100.00 %	-
Harmonics	Ok	100.00 %	100.00 %	100.00 %	-
Signaling Voltage	Ok	100.00 %	100.00 %	100.00 %	-

10:21:57 | BACK | ACTUAL REPORT

Display of current status of PQ parameters for previous monitoring period. Some are currently not in compliance with EN 50160

Online monitoring of PQ parameters and reports overviewing is easier with QDSP2.1 software.

The screenshot shows the 'Measurements' window in MiQen 2.1. It displays two tables: 'Actual monitoring period' (Report: 06/2016) and 'Previous monitoring period' (Report: 06/2016). The tables compare parameters like Frequency Variations, Voltage Variations, Voltage Unbalances, Rapid voltage changes, Flickers Pst, Voltage Dips, Voltage Swells, Short Interruptions, Long Interruptions, THD's, and Harmonics against compliance standards (EN 50160) and required quality levels.

Actual monitoring period	Start date	End date	Status	Compliance	Standard	Required Quality
Report: 06/2016	11.2.2016	11.2.2016	Not complete	Failed	EN 50160	
Parameter	L1 (System)	L2	L3	Multi Phase	Compliance	Required Quality
Frequency Variations 1	100.00 %				OK	99.5 % / Week
Frequency Variations 2	100.00 %				OK	100 % / Week
Voltage Variations 1	100.00 %	100.00 %	100.00 %		OK	95 % / Week
Voltage Variations 2	100.00 %	100.00 %	100.00 %		OK	100 % / Week
Voltage Unbalances	0.00 %				Failed	95 % / Week
Rapid voltage changes	0	0	0	0		Info only
Flickers Pst	100.00 %	100.00 %	100.00 %		OK	95 % / Week
Voltage Dips	0	0	0	0		Info only
Voltage Swells	0	0	0	0		Info only
Short Interruptions	0	0	0	0		Info only
Long Interruptions	0	0	0	0		Info only
THD's	100.00 %	100.00 %	100.00 %		OK	95 % / Week
Harmonics	100.00 %	100.00 %	100.00 %		OK	95 % / Week
Signaling voltage	100.00 % / 100.00 %	100.00 % / 100.00 %	100.00 % / 100.00 %		OK	99 % / Day
EN 61000-4-30	L1 (System)	L2	L3			
Flickers Pst	100.00 %	100.00 %	100.00 %			
Previous monitoring period	Start date	End date	Status	Compliance	Standard	
Report: 06/2016	8.11.2012	11.2.2016	Not complete	Failed	EN 50160	
Parameter	L1 (System)	L2	L3	Multi Phase	Compliance	Required Quality
Frequency Variations 1	100.00 %				OK	99.5 % / Week
Frequency Variations 2	100.00 %				OK	100 % / Week
Voltage Variations 1	100.00 %	100.00 %	100.00 %		OK	95 % / Week
Voltage Variations 2	100.00 %	100.00 %	100.00 %		OK	100 % / Week
Voltage Unbalances	0.00 %				Failed	95 % / Week
Rapid voltage changes	0	0	0	0		Info only
Flickers Pst	100.00 %	100.00 %	100.00 %		OK	95 % / Week
Voltage Dips	0	0	0	0		Info only

Presentation of PQ parameters and overall compliance status for actual and previous monitoring period – Table view

For all parameters, the following basic information is shown:

**Actual quality**

Actual quality is for some parameters expressed as a percentage of time, when parameters were inside limit lines and for others (events) it is expressed as a number of events within the monitored period.

Actual quality is for some parameters measured in all three phases and for some only in a single phase (e.g. frequency). Events can also occur as Multi-Phase events (more about multiphase events is described in following chapters)

Events are evaluated on a yearly basis according to EN 50160. Actual quality information is therefore combined of two numbers (x / y) as shown in the figure above, where:

- X ... number of events in monitored period
- Y ... total number of events in current year

**Required quality**

Required quality is a limit for compliance with standard EN 50160 and is directly compared with actual quality. The comparison result is the actual status of compliance.

More information about the required quality limits can be found in standard EN 50160.

**PLEASE NOTE**

To make the complete quality report the aux. power supply for ISTAT M365A/M365B should not be interrupted during the whole period for which the report is requested. If firmware is updated or power supply is interrupted within a monitoring period, quality report is incomplete – Status: Not complete.

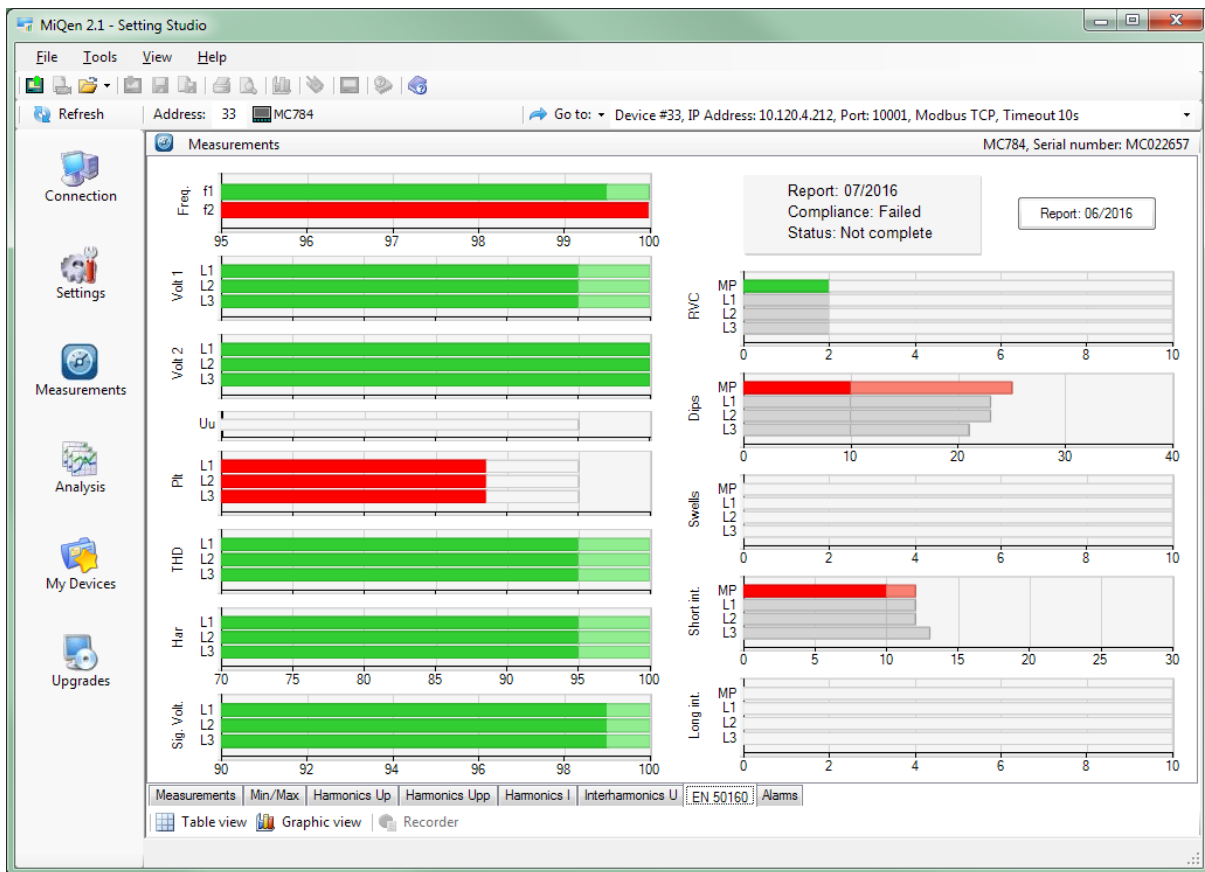

Graphical presentation of PQ parameters and overall compliance are available only for actual monitoring period:

- Darker green color marks required quality
- Light green color marks actual quality
- Red color marks incompliance with standard EN 50160
- Grey color at events marks number of events
- MP at events marks Multi phase events

## PQ records

Even more detailed description about PQ can be obtained by accessing PQ reports with details about anomalies in internal memory.

Structure and operation of internal memory and instructions on how to access data in internal memory is described in chapters *Device management and Internal memory*.

After memory has been read information about downloaded data is shown.

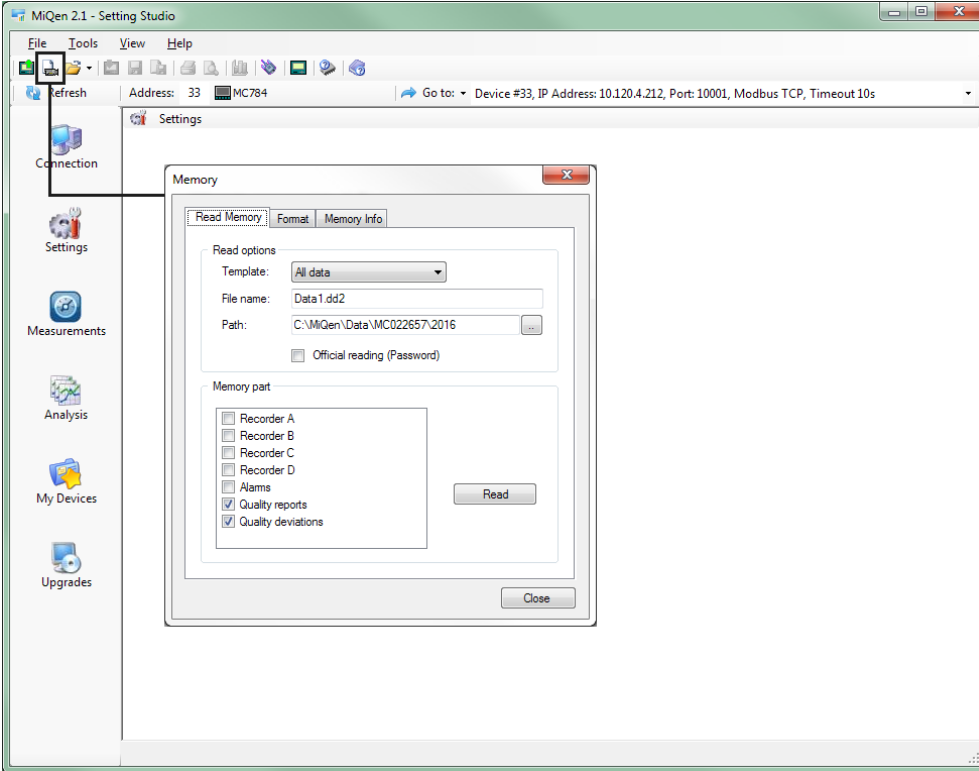

Read Power Quality memory

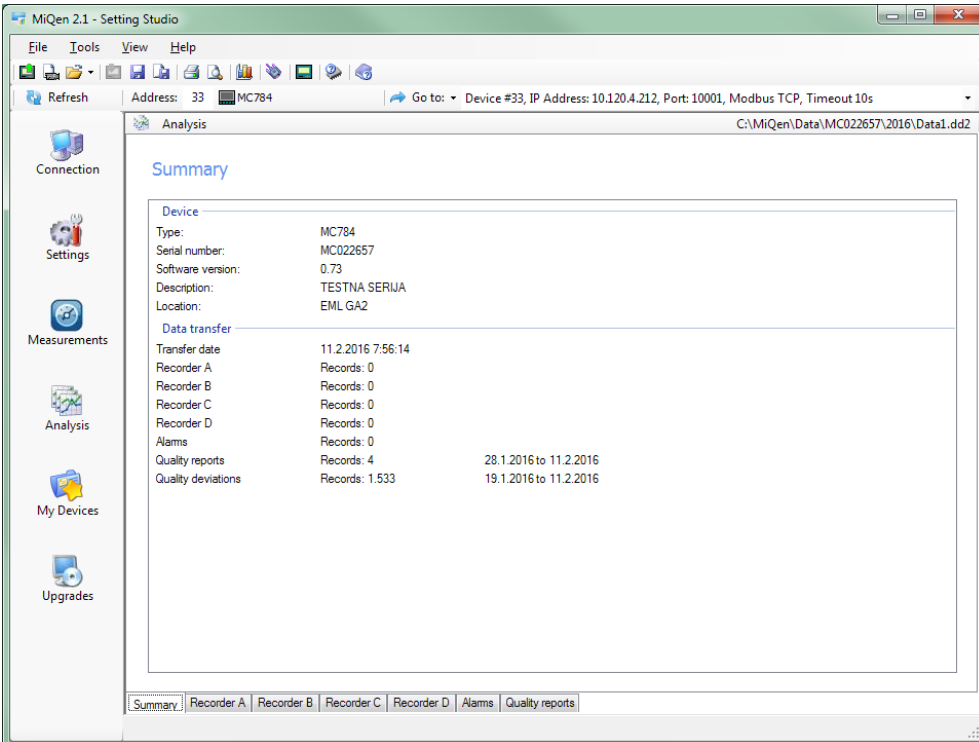

Information about downloaded data with tabs for different memory partitions

All information about PQ is stored in the Quality reports tab.

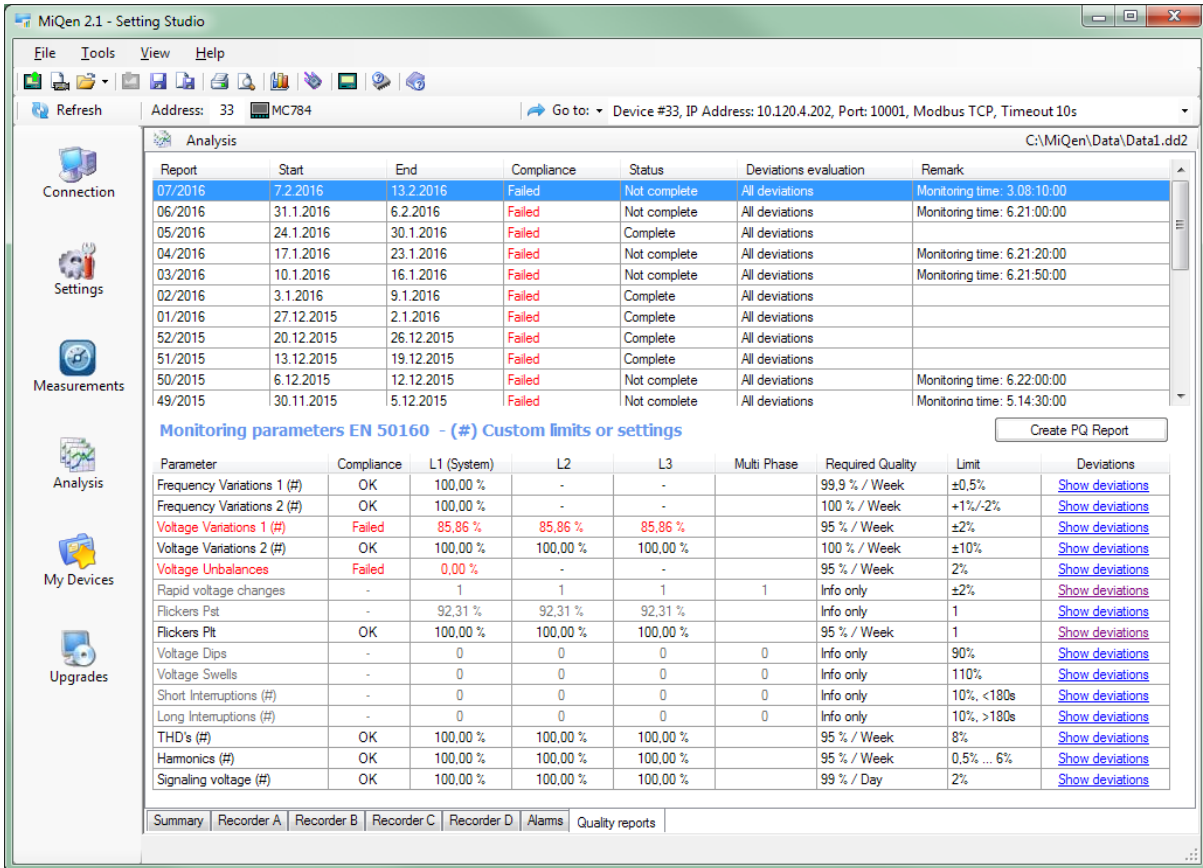

Main window of recorded PQ reports

The main window is divided into two parts. Upper part holds information about recorded periodic PQ reports and lower part about each of the upper reports.

For each of the monitored parameters it is possible to display an anomaly report. This represents a complete list of accurately time stamped measurements that were outside PQ limit lines.

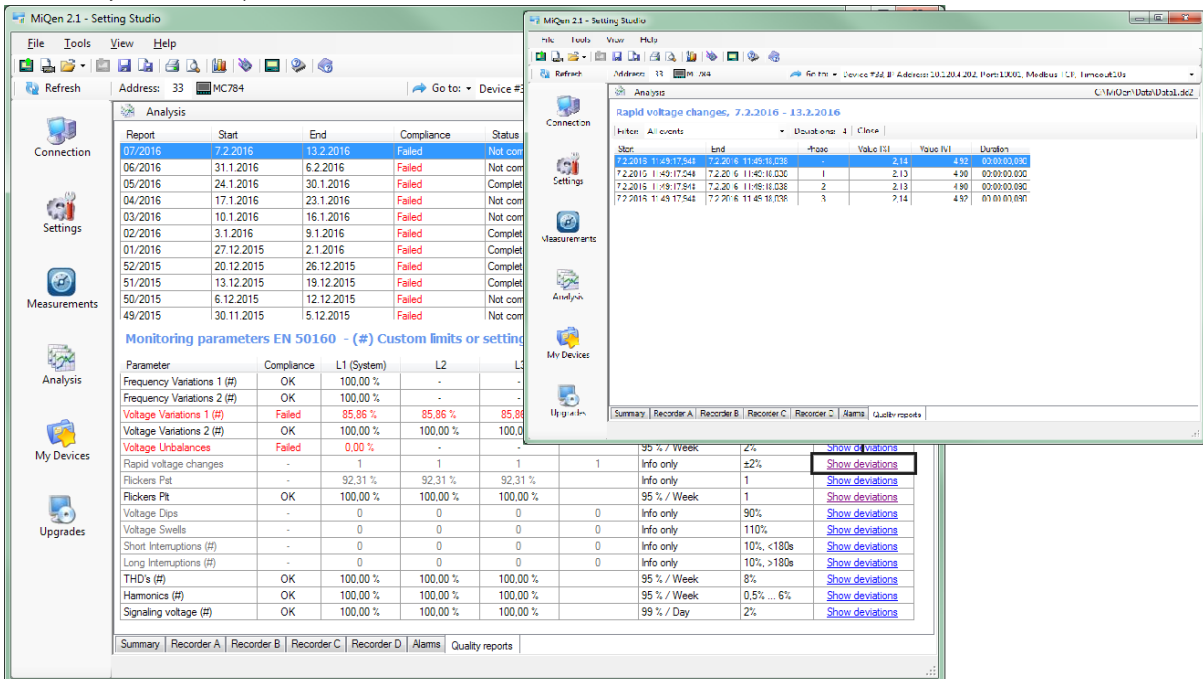

By clicking on "Show details" for each PQ parameter QDSP.2.1 displays time-stamped measurements (events), which were outside limit lines

## Flagged data evaluation

Flagged data represent data (recorded events) that has been flagged (marked) according to the flagging concept IEC 61000-4-30.

Flagged data are power quality records, which have been influenced by one or more voltage events (interruptions, dips, swells).

The purpose of flagging data is to mark recorded parameters when certain disturbances might influence measurements and cause corrupted data. For example, voltage dip can also trigger the occurrence of flicker, inter-harmonics ... In this case all parameters which were recorded at a time of voltage events are marked (flagged).

A PQ report will omit or include flagged data according to appropriate settings (please see chapter *Settings – Conformity of voltage with EN 50160 standard – Flagged events setting*).

### PLEASE NOTE

Regardless of this setting, readings will always be stored in recorder and available for analysis. Flagging only influences PQ reports as a whole.

In evaluation of PQ parameter details it is possible to show:

- All events
- Non-flagged events

As depicted in the figure below.

#### Flickers PIt, 20.12.2015 - 26.12.2015

Filter:	Non Flagged deviations		Deviations: 8	Close				
Start	All events	Phase	Average	Duration	Flagged			
24.12.2015 12:00:00	Non Flagged deviations	3	1,11	08:00:00	No			
24.12.2015 14:00:00	24.12.2015 20:00:00	1	1,10	06:00:00	No			
24.12.2015 14:00:00	24.12.2015 18:00:00	2	1,11	04:00:00	No			
24.12.2015 22:00:00	25.12.2015 00:00:00	3	1,05	02:00:00	No			
25.12.2015 04:00:00	25.12.2015 08:00:00	1	1,05	04:00:00	No			
25.12.2015 04:00:00	25.12.2015 06:00:00	3	1,02	02:00:00	No			
25.12.2015 06:00:00	25.12.2015 08:00:00	2	1,34	02:00:00	Yes			
25.12.2015 06:00:00	25.12.2015 08:00:00	3	1,43	02:00:00	Yes			

Display of all or non-flagged events

## Multiphase events

According to the EN 50160 standard events (interruptions, dips, swells) should be multiphase aggregated.

Multiphase aggregation is a method where events, which occur in all phases at a same time, are substituted with a single multiphase event since they were most likely triggered by a single anomaly in a network.

However, to eliminate possibility of information loss all events should be recorded. Therefore during a multiphase anomaly four events are recorded. Three events for each phase and an additional multiphase event.

#### Rapid voltage changes, 20.12.2015 - 26.12.2015

Filter:	All events		Deviations: 3	Close				
Start	All events	Phase	Value [%]	Value [V]	Duration			
24.12.2015 06:45:24,690	Phase events	1,730	-	-5,67	-13,04	00:00:00,040		
24.12.2015 06:45:24,690	Multi Phase events	2	-	-5,67	-13,04	00:00:00,040		
24.12.2015 06:45:24,697	24.12.2015 06:45:24,727	3	-	-5,23	-12,03	00:00:00,030		

“Phase” column in a list of events marks multiphase event with “-“. In this example one event accrued on second phase, one on third phase and one is a multiphase event.

Definition for multiphase dip and swell is:

“Multiphase event starts when voltage on one or more phases crosses threshold line for event detection and ends when voltage on all phases is restored to normal value”

Definition for multiphase interruption is:

“Multiphase interruption starts when voltage on all three phases crosses threshold line for interruption detection and ends when voltage on at least one phase is restored to normal value”

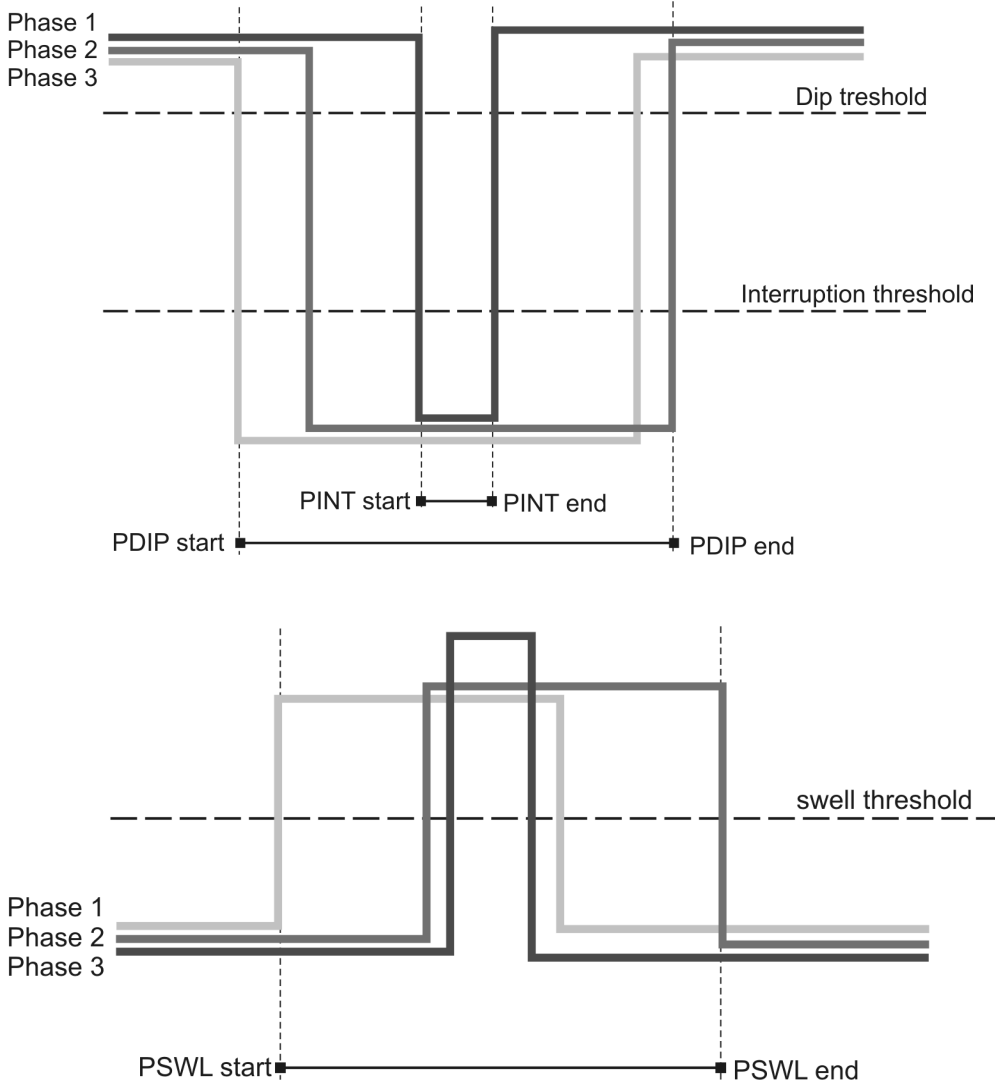

Graphical presentation of multiphase (PDIP, PINT, PSWL) event detection

Voltage event details are displayed in two ways. First as a list of all events with all details and second in a table according to UNIPEDD DISDIP specifications.

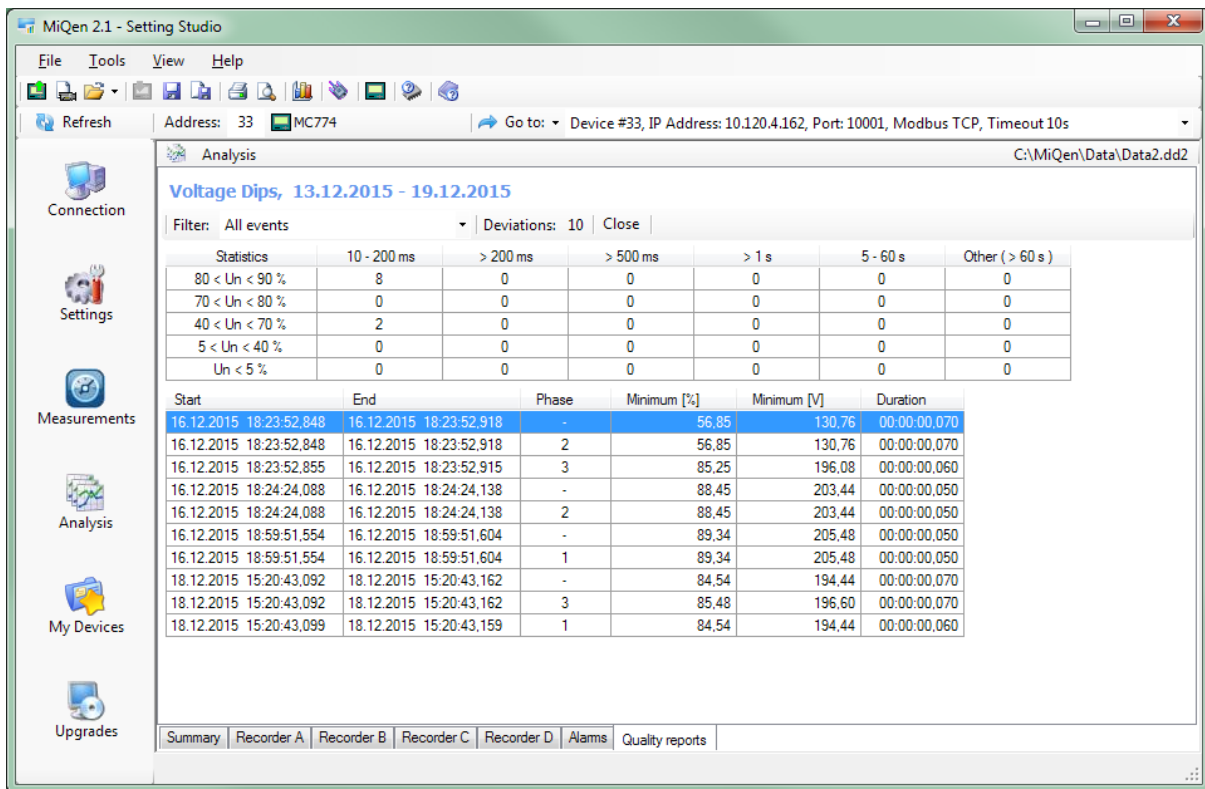

Presentation of Dips and Interruptions in a list (only four events) and in a statistics table

## LCD navigation

### M365B

Main menu
<b>Measurements</b>
Settings
Resets
SD card
Info
Installation
28.7.2014 16:53:36



Measurements
Present values
Min/Max values
Alarms
Graphs time
Graphs FFT
Power supply quality
Demo cycling
↩ Main menu

- 🔊 Main menu > Measurements > Present values > Voltage / Current / Power / PF & Power angle / Frequency / Energy / MD values / THD / Flickers / Custom / Overview / Analog input
- 🔊 Main menu > Measurements > Min/Max values > Phase Voltage / Phase-Phase Voltage / Current / Active Power / Apparent Power / Frequency / Date&Time of Reset
- 🔊 Main menu > Measurements > Alarms > Group 1 / Group 2 / Group 3 / Group 4
- 🔊 Main menu > Measurements > Graphs time > Phase Voltage / Phase-Phase Voltage / Current
- 🔊 Main menu > Measurements > Graphs FFT > Phase Voltage / Phase-Phase Voltage / Current
- 🔊 Main menu > Measurements > Power supply quality > Actual period / Previous period
- 🔊 Main menu > Measurements > Demo cycling

## M365A

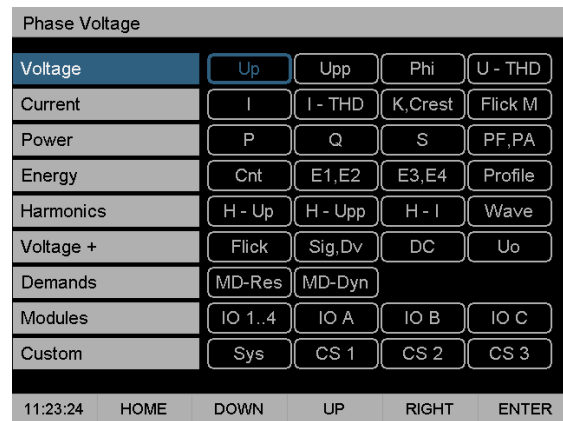
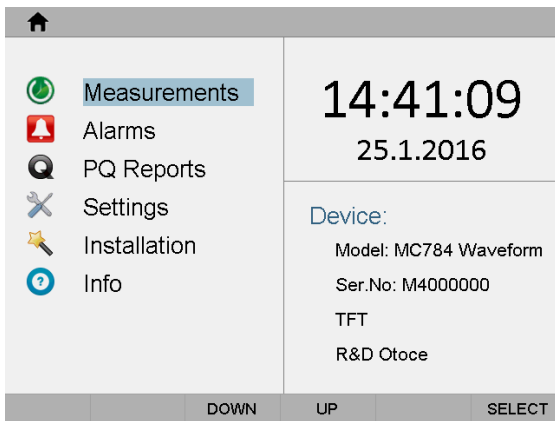

Main menu > Measurements:

- Voltage
- Current
- Power
- Energy
- Harmonics
- Voltage +
- Demands
- Modules
- Custom

## PQDIF and COMTRADE files on M365A/M365B – concept description

ISTAT M365A/M365B stores recorded data in standardized PQDIF and COMTRADE file formats. This concept was introduced for compatibility purposes with 3rd party software, which enable data viewing and analyzing by means of simple file importing.

The PQDIF acronym stands for Power Quality Data Interchange Format, and represents a binary file format according to the IEEE Std. 1159.3-2003. The primary purpose for introducing this standard was to exchange voltage, current, power, and energy measurements between software applications. The COMTRADE acronym stands for Common Format for Transient Data Exchange, and represents a file format specified in IEEE Std. C37.111. This file format was defined for storing oscillography and status data related to transient power system disturbances.

For viewing records of both types we recommend the PQDiffactor Viewer which can be freely downloaded from <http://www.electrotek.com/pqdiffactor/> or any of the software supporting these formats.

ISTAT M365A/M365B instrument has a list of advanced recorders (which are described in chapter *Settings –Advanced recorders*). These recorders are listed below together with their file storage options:

Recorder Type	Supported file record format
Waveform recorder	PQDIF and COMTRADE
Disturbance recorder	PQDIF and COMTRADE
PQ recorder	PQDIF
4 Fast Trend Recorders	PQDIF

Apart from selecting which one of the available file formats data will be stored-in, some other file record related parameters must also be specified when setting up the a recorder. These parameters are recording resolution, recorded parameters, pretrigger/posttrigger time (for Waveform and Disturbance recorders only) and file generation period (for fast trend periodic recorder).

## Working with PQDIF and COMTRADE files on the device

All created recorder files can be accessed through FTP. This is normally done through the QDSP2.1 setting & Analysis software within the My Devices section of the SW. Another way is to directly connect to ISTAT M365A/M365B using one of the standard FTP clients. To see how data in the internal device recorder is structured please see Appendix D.

### Accessing PQDIF files

Under every one of the advanced recorders a desired file format can be chosen by the user. For the PQ advanced recorder this selection is shown below:

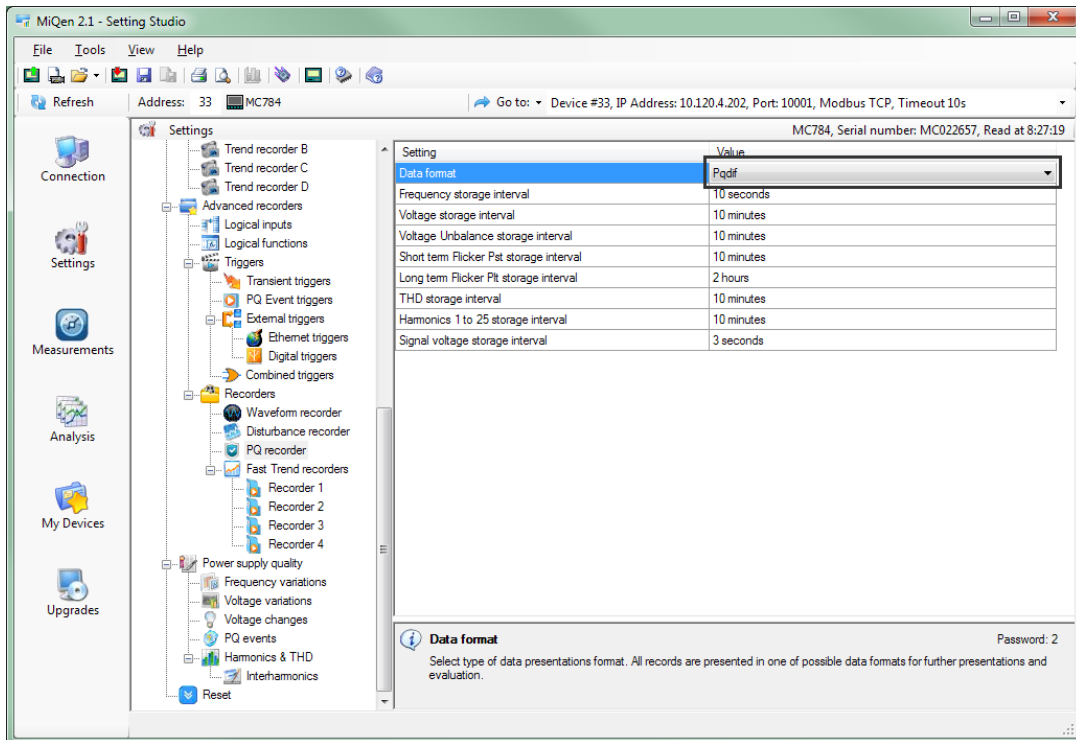

QDSP2.1 – Select type of data presentations format PQdif

## Procedure of accessing PQDIF files:

In order to access PQDIF files which are stored on the device the device first needs to be added to My devices. To do this the device from which you require recorded data should first be selected from the list of available devices or by directly entering its' communication settings:

QDSP2.1 – Choosing a device from a list

By clicking on Add to My devices we can add the chosen instrument into My devices:

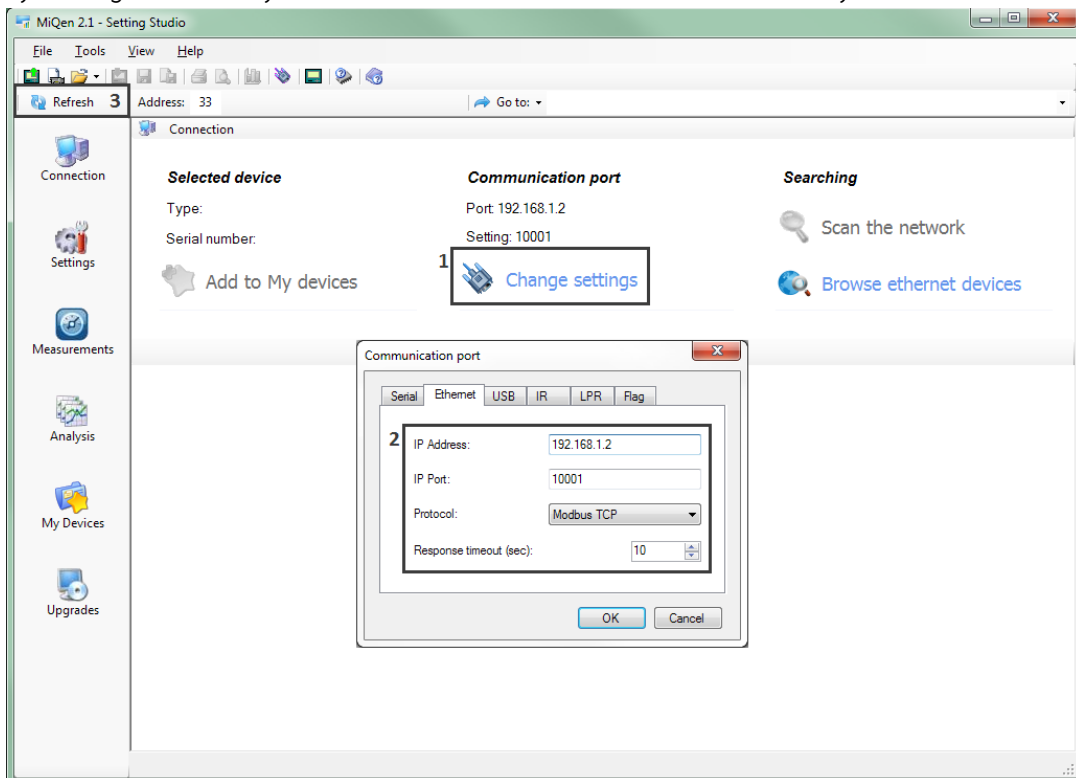

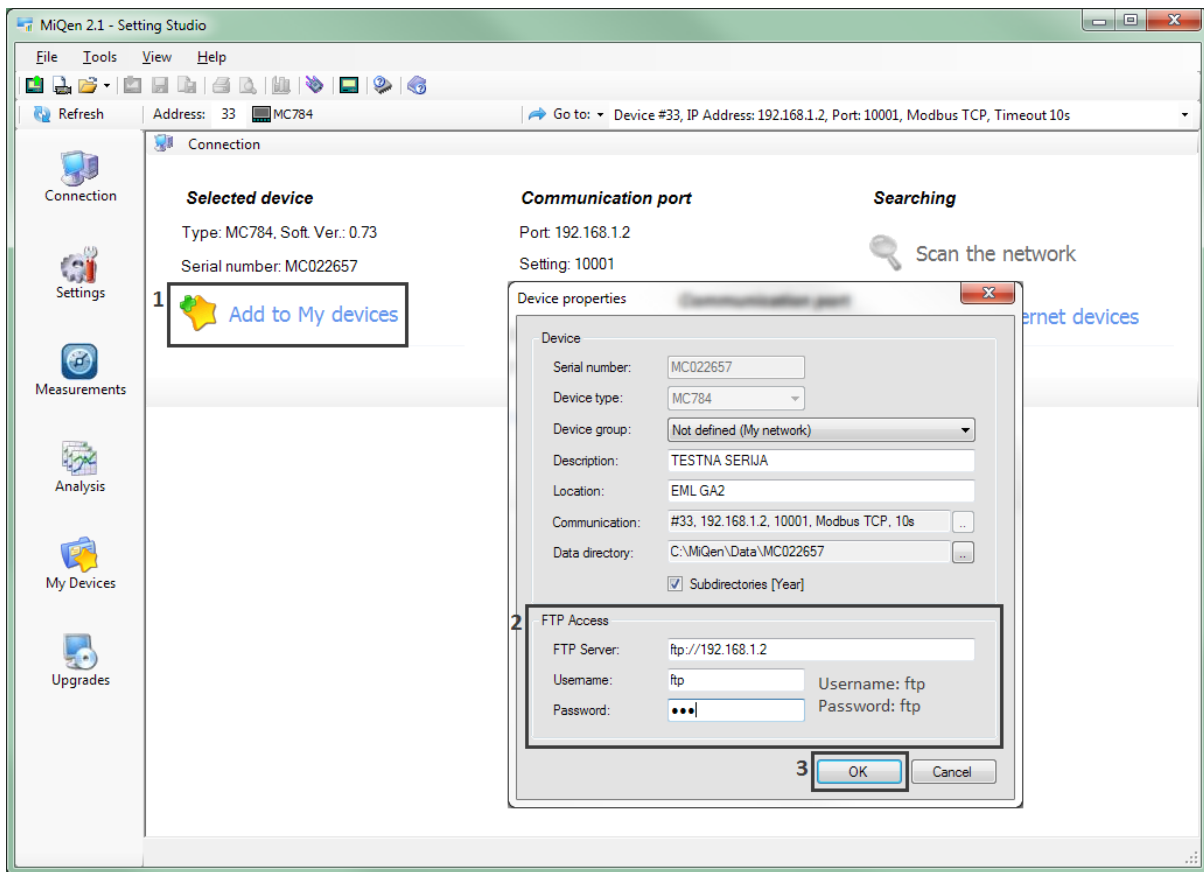

QDSP2.1 – Add the device to My devices

A dialog box appears where the user chooses basic parameters such as PQDIF file storage location and FTP credentials:

The default read-only access username and password are:

Username: ftp

Password: ftp

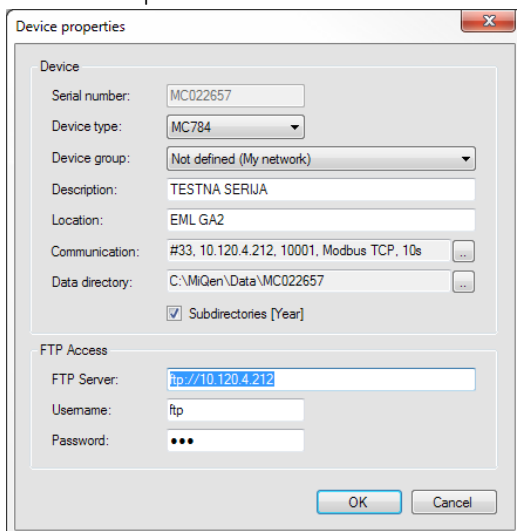

QDSP2.1 – Entering device properties within My devices

After this click, My devices tab located in the bottom left and the FTP Download tab at upper right:

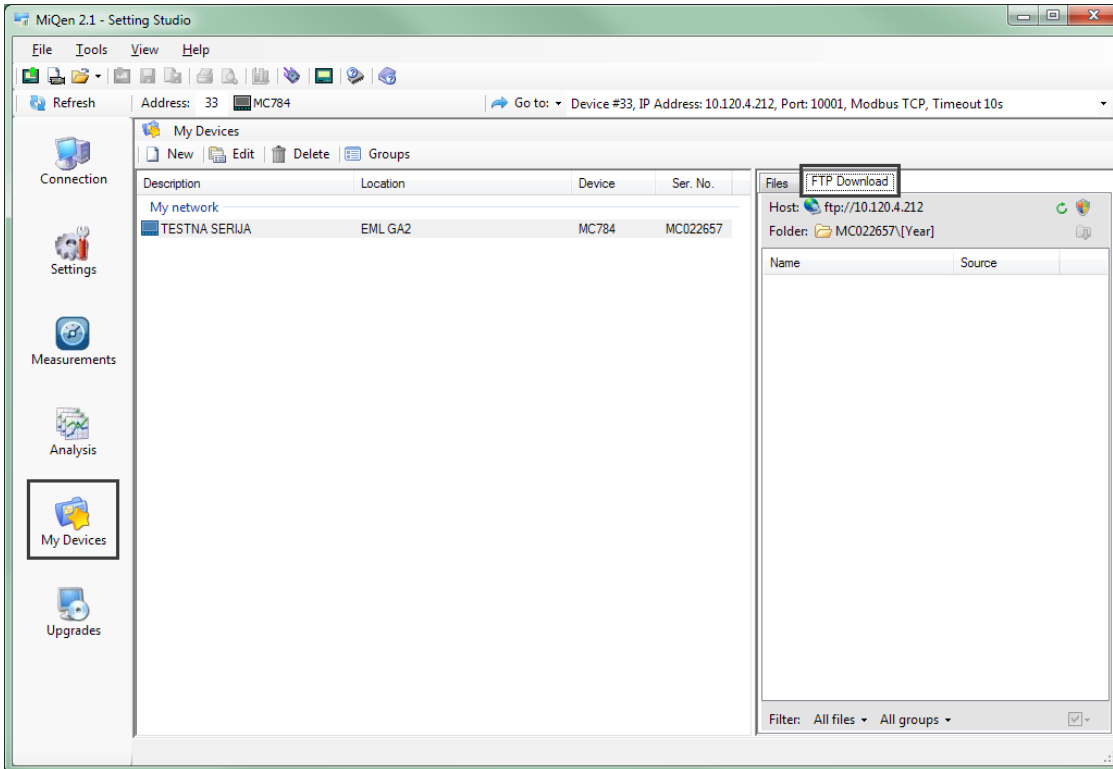

QDSP2.1: Accessing data through My devices

To refresh a list of files the upper right corner refresh  button should be pressed:

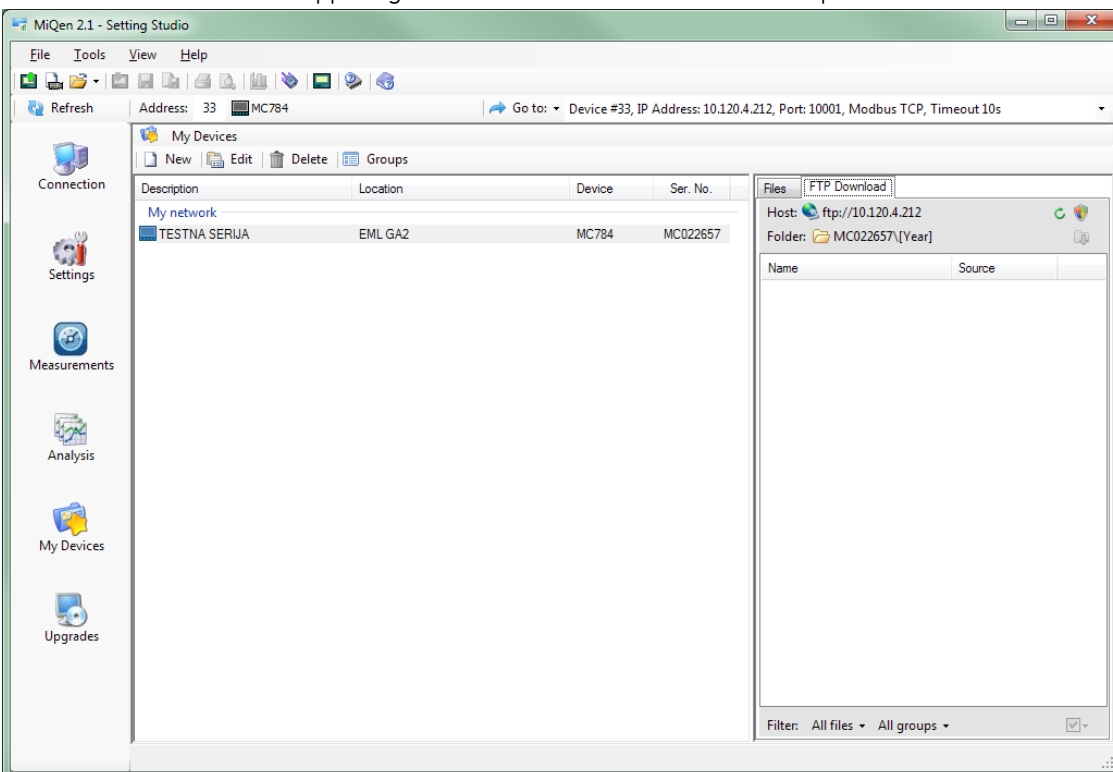

QDSP2.1 - Displaying recorded PQDIF files via FTP

Next, the required files for download are chosen by filtering them or marking the desired ones:

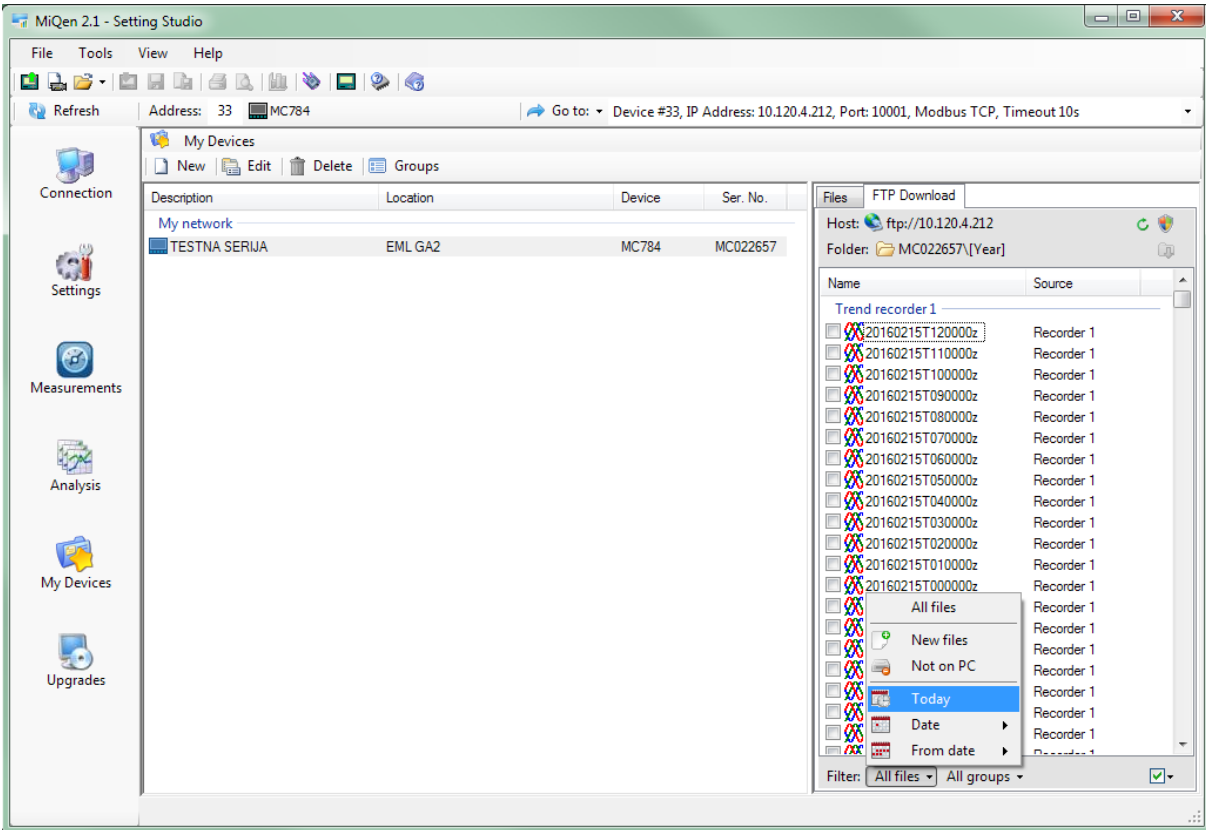

QDSP2.1 – Selection of files for download

To download the selected files click on Download selected:

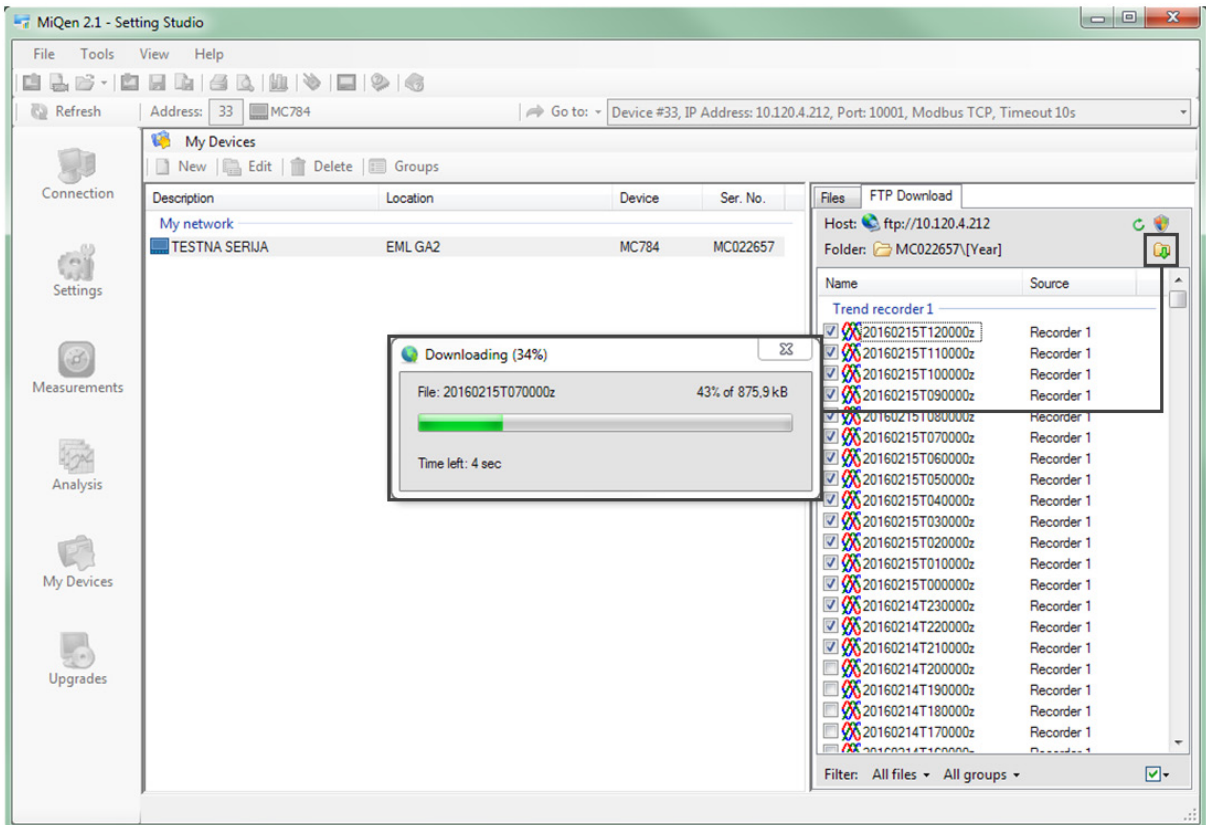

QDSP2.1 – Downloading selected files

Files are saved in the previously defined folder. This folder can be found under the tab named "files". If you double click the files tab, you can directly open saved files with PQDiffactor, or any other PQDIF file reader that was previously installed for viewing PQDIF files (look in section PQDiffactor below). For the whole file structure and terminology please see APPENDIX E.

PQDIF files are then arranged in folders according to event type as shown below:

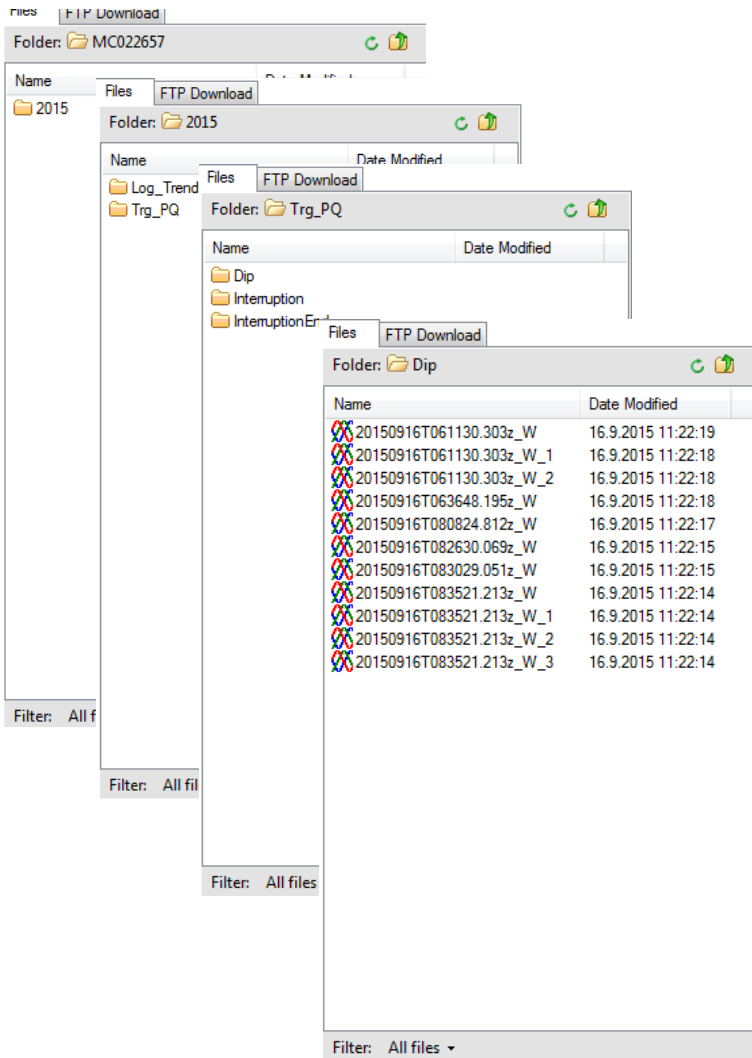

QDSP2.1 - Organization of saved files

A FW upgrade process for the ISTAT M365A/M365B which is currently open by clicking the icon shown in the figure below:

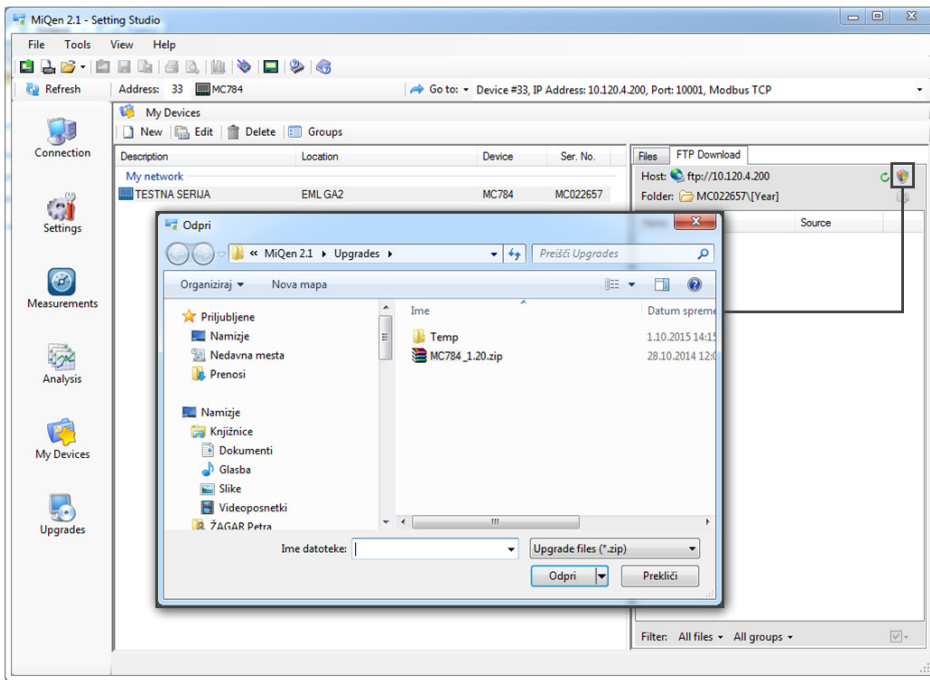

QDSP2.1 - Upgrade

## Accessing COMTRADE files

When using Waveform or Disturbance advanced recorder the COMTRADE can be chosen:

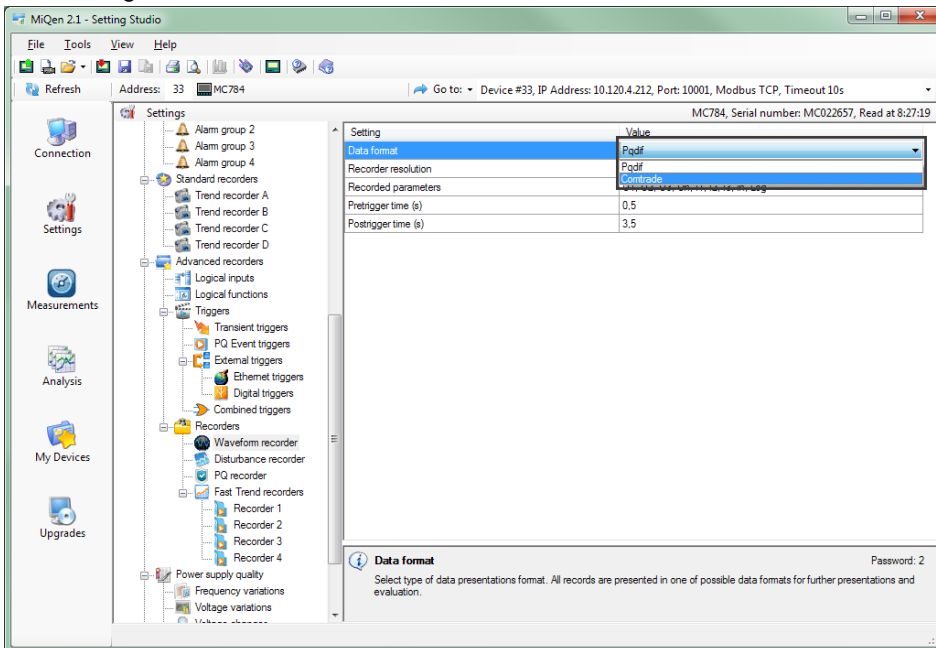

QDSP2.1 - Select COMTRADE file type for data presentations

The procedure for accessing these files is the same as for accessing PQDIF files (see Chapter Accessing PQDIF files). Under the file tab two files (.cfg and .dat file) need to be selected for storing one record in PQDIF format. Both files need to be downloaded in order to access all the data, which can then be opened as one COMTRADE document in a program such as PQDiffactor (Available free of charge for download).

The following icons denote these two file types:

.CFG FILE icon: 

.DAT FILE icon: 

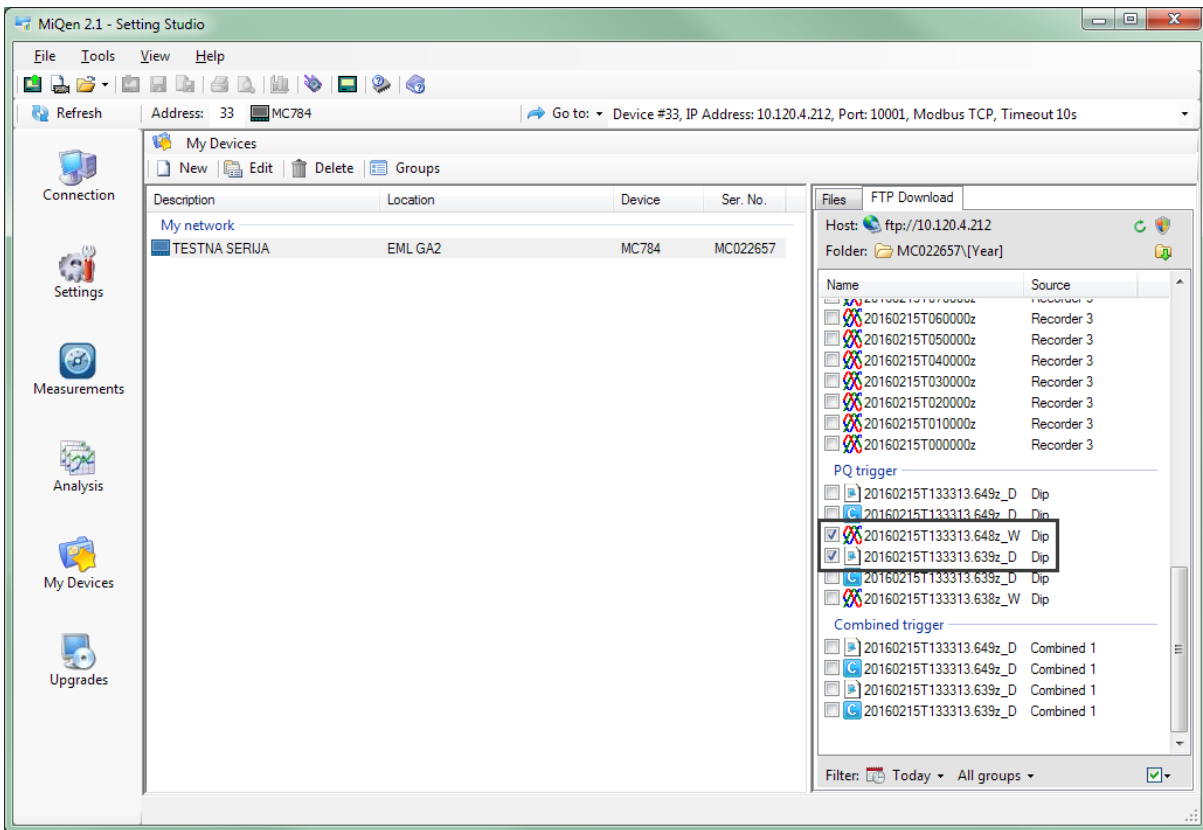

QDSP2.1 – Selecting COMTRADE files for download

Under the files tab you can find .cfg files. By clicking on the file you can also open the .dat file that was saved in the background.

## PQDiffactor - PQDIF and COMTRADE file viewer

To open PQDIF and COMTRADE files we recommend installing PQDiffactor or some other program to read these files.

An example of a PQDIF file opened in the PQDiffactor program is seen in the image below where a voltage interruption PQ event can be seen:

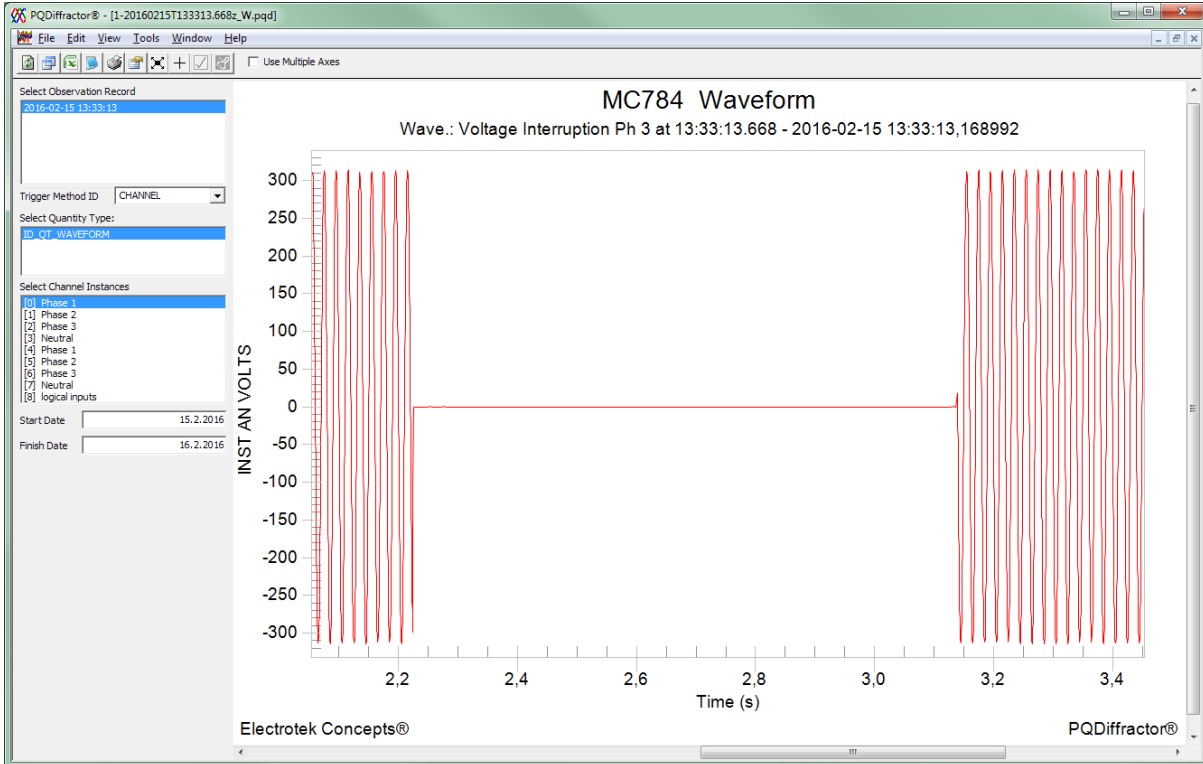

QDSP2.1 – Displaying a PQDIF file in PQDiffactor (voltage interruption action)

# TECHNICAL DATA

In following chapter all technical data regarding operation of ISTAT M365A/M365B is presented.

## Accuracy

Accuracy is presented as percentage of reading of the measured value except when it is stated as an absolute value. All values required for PQ analysis, which should be measured according to IEC61000-4-30 correspond to Class A accuracy. The following table states accuracies as well as measuring ranges of all measured values:

Measured values	Measuring Range (Direct connection)	Accuracy class	
		Standard	Class
Active power	1.8 - 18 kW ( $I_n = 5$ A)	IEC61557-12	0.2
	0 - 1.8 kW ( $I_n = 1$ A)	IEC61557-12	0.5
Reactive power	0 - 18 kvar	IEC61557-12	1(0.5)
Apparent power	0 - 18 kVA	IEC61557-12	0.2
Active energy	9 digit	IEC61557-22	0.2S
Reactive energy	9 digit	IEC62053-24	0.5s
Apparent energy	9 digit	IEC61557-12	0.2
Rms current ( $I_1, I_2, I_3, I_{avg}$ ) ( $I_{n\_meas}$ ) ( $I_{n\_calc}$ )	0,001 to 12.5 Arms $I_n = 1$ A or 5A $I_n = 1$ A or 5A <sup>(1)</sup> $I_n = 1$ A or 5A	IEC61557-12	0.1
			0.2
			0.5
Rms phase voltage ( $U_1, U_2, U_3, U_{n-g}, U_{avg}$ )	$U_{meas}: 10 - 600$ V <sub>L-N</sub> $U_{din} = 120/230$ V	IEC61557-12	0.1
		IEC61000-4-30	Class A
Rms phase-to-phase voltage ( $U_{12}, U_{23}, U_{31}, U_{avg}$ )	18 - 1000 V <sub>L-L</sub>	IEC61557-12	0.1
		IEC61000-4-30	Class A
Voltage negative sequence unbalance <sup>(2)</sup> ( $U_2$ )	10 - 600 V <sub>L-N</sub>	IEC61557-12	0.2
		IEC61000-4-30	Class A
Voltage zero sequence unbalance <sup>(2)</sup> ( $U_0$ )	10 - 600 V <sub>L-N</sub>	IEC61557-12	0.2
		IEC61000-4-30	Class A
Voltage flicker (Pst, Plt)	0.2 Pst - 10 Pst	IEC61000-4-15	Class F1 <sup>(2)</sup>
		IEC61000-4-30	Class A
Frequency - actual ( $f$ )	50 / 60Hz	IEC61557-12	0.02
		IEC61000-4-30	Class A
Frequency - (10 s average) ( $f_{10s}$ )	50 / 60 Hz	IEC61557-12	0.02
		IEC61000-4-30	Class A
Nominal frequency range	16...400 Hz	IEC61557-12	0.02

<sup>(1)</sup> Accurate measurements of neutral current ( $I_{n\_meas}$ ) at lower frequencies (16Hz - 30Hz) are possible up to 6Arms

<sup>(2)</sup> Voltage unbalance is measured as amplitude and phase unbalance  $U_{nb}$

Measured values	Measuring Range (Direct connection)	Accuracy class	
		Standard	Class
Power factor ( $PF_A$ )	-1(C)...0...+1(L)	IEC61557-12	0.5
Voltage swells ( $U_{swl}$ )	100 - 120 % $U_{din}$	IEC61557-12 IEC61000-4-30	0.2, $\pm 1$ cyc Class A
Voltage dips ( $U_{dip}$ )	5 - 100 % $U_{din}$	IEC61557-12 IEC61000-4-30	0.2, $\pm 1$ cyc Class A
Voltage interruptions ( $U_{int}$ )	0 - 5 % $U_{din}$	IEC61557-12 IEC61000-4-30	$\pm 1$ cyc Class A
THDU <sup>(3)</sup>	10 - 200% of IEC61000-4-2 Class 3 Up to 4kHz	IEC61557-12 IEC61000-4-7 IEC61000-4-30	0.3 Class I Class A
Voltage harmonics ( $U_{h_{1-n}}$ , $U_{h_{1-l}}$ )	10 - 200% of IEC61000-4-2 Class 3 Up to 4kHz (63 <sup>rd</sup> )	IEC61557-12 IEC61000-4-7 IEC61000-4-30	0.15 Class I Class A
Voltage interharmonics ( $U_{ih}$ )	10 - 200% of IEC61000-4-2 Class 3	IEC61000-4-7 IEC61000-4-30	Class I Class A
THDI <sup>(4)</sup>	Up to 4kHz	IEC61557-12	0.3
Current harmonics ( $I_h$ )	Up to 4kHz (63 <sup>rd</sup> )	IEC61557-12	0.5
Signaling voltage ( $U_{msv}$ )	Up to 3kHz	IEC61000-4-30	Class A
Real time clock (RTC)	synchronized unsynchronized	IEC61000-4-30	Class A < $\pm 1$ sec/day

<sup>(3)</sup> Test specifications for flickermeter according to standard IEC61000-4-15:2010

<sup>(4)</sup> When measuring THD, user can set how it is calculated (as a % of fundamental or as a % from RMS value)

## Measurement inputs

### Frequency:

Nominal frequency range	50, 60 Hz
Measuring frequency range	16 – 400 Hz

### Voltage measurements:

Number of channels	4 <sup>(1)</sup>
Min. voltage for sync.	1 V <sub>rms</sub>
Nominal value (U <sub>N</sub> )	500 V <sub>LN</sub> , 866 V <sub>LL</sub>
Max. measured value (cont.)	600 V <sub>LN</sub> ; 1000 V <sub>LL</sub>
Max. allowed value	1.2 × U <sub>N</sub> permanently 2 × U <sub>N</sub> ; 10 s
Consumption	< U <sup>2</sup> / 4.2 MΩ per phase
Input impedance	4.2 MΩ per phase

<sup>(1)</sup> 4<sup>th</sup> channel is used for measuring U<sub>EARTH-NEUTRAL</sub>

### Current measurements:

Number of channels	4
Nominal value (I <sub>NOM</sub> )	1 A, 5 A
Max. measured value (I <sub>1</sub> -I <sub>3</sub> only)	12.5 A sin.
Max. allowed value (thermal)	15 A cont. ≤ 300 A; 1s
Consumption	< I <sup>2</sup> × 0.01 Ω per phase

### Sampling and resolution:

Transient sampling	32 μs (625 Samples per Cycle)
ADC resolution	24 bit 8-ch simultaneous inputs
Reading refresh rate	100 ms – 5 s (User defined)

### System:

Voltage inputs can be connected either directly to low-voltage network or via a VT to higher voltage network. Current inputs can be connected either directly to low-voltage network or shall be connected to network via a corresponding CT (with standard 1 A or 5 A outputs).

## Connection



ISTAT M365A/M365B is equipped with terminals for voltage/current inputs, power supply, communications and I/O modules. ISTAT M365A/M365B current input cables shall be attached as through-hole connection without screwing.

### PLEASE NOTE

Stranded wire must be used with insulated end sleeve to assure firm connection.

Terminals	Max. conductor cross-sections DIN / ANSI housing
Voltage inputs (4)	≤ 2.5 mm <sup>2</sup> , AWG 24-12 single wire
Current inputs (3)	≤ Ø 6 mm one conductor with insulation
Supply (2)	≤ 2.5 mm <sup>2</sup> , AWG 24-12 single wire
Ground (1)	≤ 2.5 mm <sup>2</sup> , AWG 24-12 single wire
Com (5), I/O (6)	≤ 2.5 mm <sup>2</sup> , AWG 24-12 single wire

## Connection table

Function		Connection	Comment	
Measuring input	AC current	IL1	1/3	
		IL2	4/6	
		IL3	7/9	
		ILN	26/27	
	AC voltage	UL1	2	
		UL2	5	
		UL3	8	
UN	11			
Inputs / outputs	I/O module 1/2	+ / ÷	15	
		- / ÷ (common)	16	
		+ / ÷	17	
	I/O module 3/4	+ / ÷	18	
		- / ÷ (common)	19	
		+ / ÷	20	
	I/O module A	- / ÷ (common)	30	
		+ / ÷	31 - 38	
	I/O module B	- / ÷ (common)	40	
		+ / ÷	41 - 48	
	I/O module C	 BNC input	BNC	IRIG-B modulated (1kHz) time sync. signal
		1 pps	53	TTL level 1 pps time sync. Signal or IRIG-B digital
		RS485	54, 55	A - 54, B - 55
MODEM/RS232		56-59	Rx - 56, GND - 57, Tx - 58, +5V - 59	
Auxiliary power supply	+ / ÷ (L)	13	CAT III 300V	
	- / ÷ (N)	14		
		12	© GROUND terminal must always be connected!	
Communication	USB	Type B	USB 2.0 type B	
	ETHERNET	RJ-45	10/100 BASE-TX Ethernet	

## Communication

Power Quality Analyzer M365A/M365A is equipped with standard communication port COM1 and auxiliary communication port COM2. This allows two different users to access data from a device simultaneously and by using TCP/IP communication, data can be accessed worldwide.

The device is equipped with the following configuration:

Configuration <sup>(1)</sup>	COM1	COM2 <sup>(2)</sup>
	Ethernet & USB	RS232/485

<sup>(1)</sup> Galvanic separation between Eth. and USB is 1 kV<sub>ACRMS</sub>

<sup>(2)</sup> COM2 is NOT available if GPS time synchronization is used

### **ISTAT M365A/M365B communication configuration**

Standard communication protocols MODBUS RTU, MODBUS TCP and DNP3 L1 are supported with IEC61850 Ed.2 optionally (see appendix F).

## Input/Output modules

ISTAT M365A/M365B is equipped with two main I/O slots, two auxiliary I/O slots and special time-synchronization module. The following I/O modules are available:

Module type	Number of modules per slot	
	Main slot	Aux slot
Analogue output (AO)	2	/
Analogue input (AI)	2	/
Pulse output (PO)	2	/
Pulse input (PI)	2	/
Tariff input (TI)	2	/
Relay output (RO)	2	8
Digital input (DI)	2	8
Bistable alarm output (BO)	1	/
Watchdog / Relay output	WO / RO	/

List of available I/O modules

### Analogue input (AI):

Three types of analogue inputs are suitable for acquisition of low voltage DC signals from different sensors. According to application requirements it is possible to choose current, voltage or resistance (temperature) analogue input. They all use the same output terminals.

QDSP2.1 software allows setting an appropriate calculation factor, exponent and required unit for representation of primary measured value (temperature, pressure, wind speed ...)

### DC current input:

Nominal input range	-20 ... 0 ... 20 mA ( $\pm 20\%$ )
input resistance	20 $\Omega$
accuracy	0.5 % of range
temperature drift	0.01 % / °C
conversion resolution	16 bit (sigma-delta)
Analogue input mode	internally referenced Single-ended

### DC voltage input:

Nominal input range	-10 ... 0 ... 10 V ( $\pm 20\%$ )
input resistance	100 k $\Omega$
accuracy	0.5 % of range
temperature drift	0.01 % / °C
conversion resolution	16 bit (sigma-delta)
Analogue input mode	internally referenced Single-ended

**Resistance (temperature) input:**

Nominal input range (low)*	0 ... 200 $\Omega$ (max. 400 $\Omega$ ) PT100 (-200 °C ... 850 °C)
Nominal input range (high)*	0 ... 2 k $\Omega$ (max. 4 k $\Omega$ ) PT1000 (-200 °C ... 850 °C)
connection	2-wire
accuracy	0.5 % of range
conversion resolution	16 bit (sigma-delta)
Analogue input mode	internally referenced Single-ended

\*Low or high input range and primary input value (resistance or temperature) are set by the QDSP2.1 setting software

**Analogue output (AO):**

Output range	0 ... 20 mA
Accuracy	0.5 % of range
Max. burden	150 $\Omega$
Linearization	Linear, Quadratic
No. of break points	5
Output value limits	$\pm 120$ % of nominal output
Response time (measurement and analogue output)	depends on set general average interval (0.1 s ... 5 s)
Residual ripple	< 1 % p.p.

Outputs may be either short or open-circuited. They are electrically insulated from each other and from all other circuits. Output range values can be altered subsequently (zoom scale) using the setting software, but a supplementary error results.

**Digital input (DI)**

Purpose	Tariff input, Pulse input, General purpose digital input
Max. current	8 mA (48 V), <0.6 mA (110, 230 V)
SET voltage	40 ... 120 % of rated voltage
RESET voltage	0 ... 10 % of rated voltage
Tariff input	Main slot only
Rated voltage	(5 ... 48), 110, 230 $\pm 20$ % $V_{AC/DC}$
Frequency range	45 ... 65 Hz
Pulse input	Main slot only
Rated voltage	5 – 48 $V_{DC}$
Min. pulse width	0.5 ms
Min. pulse period	2 ms
Digital input	(5 ... 48), 110, 230 $\pm 20$ % $V_{AC/DC}$
Min. signal width	20 ms
Min. pause width	40 ms

**Bistable alarm output (BO)**

Type	Relay switch
Purpose	Alarm output, General purpose digital output
Rated voltage	230 V <sub>AC/DC</sub> ± 20 % max
Max. switching current	1000 mA (main slot) 100 mA (aux. slot, DO only)
Contact resistance	≤ 100 mΩ (100 mA, 24 V)
Impulse	Max. 4000 imp/hour Min. length 100 ms

**Status (watchdog) output (WO)**

Type	Relay switch
Normal operation	Relay in ON position
Failure detection delay	≈ 1.5 s
Rated voltage	230 V <sub>AC/DC</sub> ± 20% max
Max. switching current	1000 mA
Contact resistance	≤ 100 mΩ (100 mA, 24 V)

**Pulse output (PO)**

Type	Optocoupler open collector switch
Purpose	Pulse output
Rated voltage	40 V <sub>AC/DC</sub>
Max. switching current	30 mA (R <sub>ONmax</sub> = 8 Ω)
Pulse length	programmable (2 ... 999 ms)

**Time synchronization input**

Digital input	GPS or IRIG-B TTL
1pps voltage level	TTL level (+5 V)
Time code telegram	RS232 (GPS) DC level shift (IRIG-B)
AM analogue input	IRIG-B AM modulated
Carrier frequency	1 kHz
Input impedance	600 Ohms
Amplitude	2.5 V <sub>P-Pmin</sub> , 8 V <sub>P-Pmax</sub>
Modulated ratio	3:1 – 6:1

## Safety

Protection	protection class II
Ⓜ <sup>TM</sup> Ⓜ <sup>®</sup>	Functional earth terminal must be connected to earth potential! Voltage inputs via high impedance Double insulation for I/O ports and COM ports
Pollution degree	2
Installation category	CAT III ; 600 V
Measuring inputs	CAT IV ; 300 V Acc. to EN 61010-1
Test voltages	UAUX↔I/O, COM1: 3510 VACrms UAUX↔U, I inputs: 3510 VACrms U, I inputs↔I/O, COM1: 3510 VACrms HV I/O ↔ I/O, COM1: 3510 VACrms U inputs↔I inputs: 3510 VACrms

## Time synchronization input

Digital input	GPS or IRIG-B TTL
1pps voltage level	TTL level (+5 V)
Time code telegram	RS232 (GPS) DC level shift (IRIG-B)
AM analogue input	IRIG-B AM modulated
Carrier frequency	1 kHz
Input impedance	600 Ohms
Amplitude	2.5 V <sub>P-Pmin</sub> , 8 V <sub>P-Pmax</sub>
Modulated ratio	3:1 – 6:1

## Auxiliary Power Supply

Measurement category	CAT III 300V
Nominal voltage AC	80 ... 276 V
Nominal frequency	40 ... 65 Hz
Nominal voltage DC	80 ... 300 V
Consumption (typical)	< 8 VA
Consumption (max. all I/O)	< 12 VA (M365B) < 13 VA (M365A)
Power-on transient current	< 20 A ; 1 ms

## Mechanical

Dimensions	144 × 144 × 100 mm
Mounting	Panel mounting 144 × 144 mm
Required mounting hole	137 × 137 mm
Enclosure material	PC / ABS
Flammability	Acc. to UL 94 V-0
Weight	550 g
Enclosure material	PC / ABS Acc. to UL 94 V-0

---

## Ambient conditions

Ambient temperature	K55 temperature class Acc. to EN61557-12 -10 ... 55 °C
Storage temperature	-40 ... +70 °C
Average annual humidity	≤ 90% r.h. (no condensation)
Pollution degree	2
Enclosure protection	IP 40 (front plate) IP 20 (rear side)
Installation altitude	≤ 2000 m

## Real time clock

A built-in real time clock is also without external synchronization very stable when ISTAT M365A/M365B is connected to auxiliary power supply. For handling shorter power interruptions without influence on RTC, device uses high capacity capacitor. It ensures auxiliary supply (for internal RTC only) for more than two days of operation.

Type	Low power embedded RTC
RTC stability	< 1 sec / day

## Operating conditions

Operating conditions which have been tested for proper operation of ISTAT M365A/M365B within specified accuracy are in accordance with requirements in standards IEC61557-12, IEC61326-1, IEC61000-4-30 and IEC61000-4-7

Ambient conditions	<p>Ambient temperature K55 temperature class Acc. to EN 61557-12 -10 ... 55 °C</p> <p>Storage temperature range -40 ... +70 °C</p> <p>Ambient humidity ≤ 75% r.h. (no condensation)</p> <p>Max. storage and transport humidity ≤ 90% r.h. (no condensation)</p> <p>Voltage and Current ± 20 ppm / K</p> <p>max. temperature influence limit (10 V ... 600 V; 0,05 A ... 10 A) (<math>T_{amb}</math> : -30 °C ... +70 °C)</p>
Influence of Auxiliary Supply	<p>Voltage and Current max. aux. supply change influence limit (IEC61557-12) &lt; ± 0,02 % (Supply voltage magnitude and frequency in a specified range)</p> <p>Common mode input voltage rejection (IEC61557-12) &lt; ± 0,08 % (common mode voltage at 500 V)</p>
Influence of 2014/30/EU	<p>External A.C. field IEC61326-1 &lt; ±0,02 % Performance criteria A (IEC61000-4-2)</p> <p>Electrostatic discharges IEC61326-1 Performance criteria B (IEC61000-4-3)</p> <p>Electromagnetic RF fields IEC61326-1 Limit 1 %; &lt; ±0,4 % <sup>(a)</sup> Performance criteria A (IEC61000-4-6)</p> <p>Conducted disturbances IEC61326-1 Limit 1 %; &lt; ±0,4 % <sup>(a)</sup> Performance criteria A</p> <p><sup>(a)</sup> Test performed my measuring active energy with pulse output. Error (0.4%) is due to short measuring time</p>

# Dimensions

Dimensional drawing (All dimensions are in mm)

Construction      Appearance

<p>Dimensions</p>															
<p>Panel cut-out</p>															
<p>Enclosure</p>	<table border="0"> <tr> <td>Dimensions</td> <td>144 × 144 × 100 mm</td> </tr> <tr> <td>Mounting</td> <td>Panel mounting 144×144 mm</td> </tr> <tr> <td>Required mounting hole</td> <td>137 × 137 mm</td> </tr> <tr> <td>Enclosure material</td> <td>PC/ABS</td> </tr> <tr> <td>Flammability</td> <td>Acc. to UL 94 V-0</td> </tr> <tr> <td>Weight</td> <td>550 g</td> </tr> <tr> <td>Enclosure material</td> <td>PC/ABS</td> </tr> </table>	Dimensions	144 × 144 × 100 mm	Mounting	Panel mounting 144×144 mm	Required mounting hole	137 × 137 mm	Enclosure material	PC/ABS	Flammability	Acc. to UL 94 V-0	Weight	550 g	Enclosure material	PC/ABS
Dimensions	144 × 144 × 100 mm														
Mounting	Panel mounting 144×144 mm														
Required mounting hole	137 × 137 mm														
Enclosure material	PC/ABS														
Flammability	Acc. to UL 94 V-0														
Weight	550 g														
Enclosure material	PC/ABS														

# APPENDICES

---

## APPENDIX A: MODBUS communication protocol

### Communication protocols

Modbus and DNP3 protocol are enabled via RS232 and RS485 or Ethernet communication. Both communication protocols are supported on all communication ports of ISTAT M365A/M365B. The response is the same type as the request.

### Modbus

Modbus protocol enables operation of device on Modbus networks. For ISTAT M365A/M365B with serial communication the Modbus protocol enables point to point (for example Device to PC) communication via RS232 communication and multi drop communication via RS485 communication. Modbus protocol is a widely supported open interconnect originally designed by Modicon.

In this document main modbus registers are listed. For complete, latest, Modbus table please contact GE via [www.gegridsolutions.com/contact](http://www.gegridsolutions.com/contact)

The memory reference for input and holding registers is 30000 and 40000 respectively.

---

 **PLEASE NOTE**

---

For the latest and complete MODBUS table please please contact GE via [www.gegridsolutions.com/contact](http://www.gegridsolutions.com/contact).

---

**Register table for the actual measurements**

Parameter	MODBUS		
	Register Start	End	Type
Actual time	30101	30104	T_Time
Frequency	30105	30106	T5
Voltage U <sub>1</sub>	30107	30108	T5
Voltage U <sub>2</sub>	30109	30110	T5
Voltage U <sub>3</sub>	30111	30112	T5
Average phase Voltage U <sub>~</sub>	30113	30114	T5
Phase to phase voltage U <sub>12</sub>	30118	30119	T5
Phase to phase voltage U <sub>23</sub>	30120	30121	T5
Phase to phase voltage U <sub>31</sub>	30122	30123	T5
Average phase to phase Voltage U <sub>pp~</sub>	30124	30125	T5
Voltage neutral to ground U <sub>no~</sub>	30485	30486	T5
Voltage Zero sequence U <sub>0</sub>	35201	35202	T5
Voltage Positive sequence U <sub>1</sub>	35203	35204	T5
Voltage Negative sequence U <sub>2</sub>	35205	35206	T5
Current I <sub>1</sub>	30126	30127	T5
Current I <sub>2</sub>	30128	30129	T5
Current I <sub>3</sub>	30130	30131	T5
Neutral Current Inc (calculated)	30132	30133	T5
Neutral Current Inm (measured)	30134	30135	T5
Average Current	30136	30137	T5
Total Current I	30138	30139	T5
Current Zero sequence I <sub>0</sub>	35207	35208	T5
Current Positive sequence I <sub>1</sub>	35209	35210	T5
Current Negative sequence I <sub>2</sub>	35211	35212	T5
Real Power P <sub>1</sub>	30142	30143	T6
Real Power P <sub>2</sub>	30144	30145	T6
Real Power P <sub>3</sub>	30146	30147	T6
Total Real Power P	30140	30141	T6
Reactive Power Q <sub>1</sub>	30150	30151	T6
Reactive Power Q <sub>2</sub>	30152	30153	T6
Reactive Power Q <sub>3</sub>	30154	30155	T6
Total Reactive Power Q	30148	30149	T6
Fundamental reactive power Total (Qbt)	35221	35222	T6
Fundamental reactive power Phase L1 (Qb1)	35223	35224	T6
Fundamental reactive power Phase L2 (Qb2)	35225	35226	T6
Fundamental reactive power Phase L3 (Qb3)	35227	35228	T6
Apparent Power S <sub>1</sub>	30158	30159	T5
Apparent Power S <sub>2</sub>	30160	30161	T5
Apparent Power S <sub>3</sub>	30162	30163	T5
Total Apparent Power S	30156	30157	T5
Deformed power Total (Dt)	35229	35230	T6
Deformed power Phase L1 (D1)	35231	35232	T6
Deformed power Phase L2 (D2)	35233	35234	T6
Deformed power Phase L3 (D3)	35235	35236	T6

**Register table for the actual measurements**

Parameter	MODBUS		
	Register		Type
	Start	End	
Power Factor PF1	30166	30167	T7
Power Factor PF2	30168	30169	T7
Power Factor PF3	30170	30171	T7
Total Power Factor PF	30164	30165	T7
Displacement Power Factor Total (dPFt)	35213	35214	T7
Displacement Power Factor Phase 1 (dPF1)	35215	35216	T7
Displacement Power Factor Phase 2 (dPF2)	35217	35218	T7
Displacement Power Factor Phase 3 (dPF3)	35219	35220	T7
Power Angle U1-I1	30173		T17
Power Angle U2-I2	30174		T17
Power Angle U3-I3	30175		T17
Angle between In and Un	30488		T17
Power Angle atan2(Pt, Qt)	30172		T17
Angle U1-U2	30115		T17
Angle U2-U3	30116		T17
Angle U3-U1	30117		T17
Angle Un-U1	30487		T17
Voltage unbalance Uu	30176		T16
Voltage unb. zero sequence Uo	30177		T16
U1 Signal voltage Abs	30592	30593	T5
U2 Signal voltage Abs	30594	30595	T5
U2 Signal voltage Abs	30596	30597	T5
THD I1	30188		T16
THD I2	30189		T16
THD I3	30190		T16
THD U1	30182		T16
THD U2	30183		T16
THD U3	30184		T16
THD U12	30185		T16
THD U23	30186		T16
THD U31	30187		T16
Internal Temperature	30181		T2
DC Voltage U1	30471	30472	T6
DC Voltage U2	30473	30474	T6
DC Voltage U3	30475	30476	T6
DC Voltage U12	30477	30478	T6
DC Voltage U23	30479	30480	T6
DC Voltage U31	30481	30482	T6
DC Voltage Un	30483	30484	T6
TDD I1	30491		T16
TDD I2	30492		T16
TDD I3	30493		T16
K factor I1	30494		T16
K factor I2	30495		T16
K factor I3	30496		T16
CREST factor I1	30497		T1
CREST factor I2	30498		T1
CREST factor I3	30499		T1

**Register table for the actual measurements**

Parameter	MODBUS
-----------	--------

	Register		Type
	Start	End	
CREST factor U1	30568		T1
CREST factor U2	30569		T1
CREST factor U3	30570		T1
CREST factor U12	30571		T1
CREST factor U23	30572		T1
CREST factor U31	30573		T1
Max Demand Since Last RESET			
MD Real Power P (positive)	30542	30543	T6
MD Real Power P (negative)	30548	30549	T6
MD Reactive Power Q – L	30554	30555	T6
MD Reactive Power Q – C	30560	30561	T6
MD Apparent Power S	30536	30537	T5
MD Current I1	30518	30519	T5
MD Current I2	30524	30525	T5
MD Current I3	30530	30531	T5
Dynamic Demand Values			
MD Real Power P (positive)	30510	30511	T6
MD Real Power P (negative)	30512	30513	T6
MD Reactive Power Q – L	30514	30515	T6
MD Reactive Power Q – C	30516	30517	T6
MD Apparent Power S	30508	30509	T5
MD Current I1	30502	30503	T5
MD Current I2	30504	30505	T5
MD Current I3	30506	30507	T5

**Register table for the actual measurements**

Parameter	MODBUS		
	Register Start	End	Type
Energy			
Energy Counter 1 Exponent	30401		T2
Energy Counter 2 Exponent	30402		T2
Energy Counter 3 Exponent	30403		T2
Energy Counter 4 Exponent	30404		T2
Counter E1	30406	30407	T3
Counter E2	30408	30409	T3
Counter E3	30410	30411	T3
Counter E4	30412	30413	T3
Counter E1 Tariff 1	30414	30415	T3
Counter E2 Tariff 1	30416	30417	T3
Counter E3 Tariff 1	30418	30419	T3
Counter E4 Tariff 1	30420	30421	T3
Counter E1 Tariff 2	30422	30423	T3
Counter E2 Tariff 2	30424	30425	T3
Counter E3 Tariff 2	30426	30427	T3
Counter E4 Tariff 2	30428	30429	T3
Counter E1 Tariff 3	30430	30431	T3
Counter E2 Tariff 3	30432	30433	T3
Counter E3 Tariff 3	30434	30435	T3
Counter E4 Tariff 3	30436	30437	T3
Counter E1 Tariff 4	30438	30439	T3
Counter E2 Tariff 4	30440	30441	T3
Counter E3 Tariff 4	30442	30443	T3
Counter E4 Tariff 4	30444	30445	T3
Counter E1 Cost	30446	30447	T3
Counter E2 Cost	30448	30449	T3
Counter E3 Cost	30450	30451	T3
Counter E4 Cost	30452	30453	T3
Active tariff	30405		T1

Actual counter is calculated:

Cnt.x 10<sup>exponent</sup>

**Register table for the actual measurements**

Parameter	MODBUS		
	Register Start	End	Type
Flickers			
Flicker Pst1	30580		T17
Flicker Pst2	30581		T17
Flicker Pst3	30582		T17
Flicker Plt1	30583		T17
Flicker Plt2	30584		T17
Flicker Plt3	30585		T17
Flicker Pf5 - L1	30586	30587	T5
Flicker Pf5 - L2	30588	30589	T5
Flicker Pf5 - L3	30590	30591	T5
Phase voltage harmonic data			
U1 Harmonic Data			
Base for % calculation	31001	31002	T5
U1 1 Harmonic Abs %	31003		T16
U1 1 Harmonic Phase Angle	31004		T17
U1 Harmonics from 2 to 62			
U1 63 Harmonic Abs %	31127		T16
U1 63 Harmonic Phase Angle	31128		T17
U2 Harmonic Data			
Base for % calculation	31129	31130	T5
U2 1 Harmonic Abs %	31131		T16
U2 1 Harmonic Phase Angle	31132		T17
U2 Harmonics from 2 to 62			
U2 63 Harmonic Abs %	31255		T16
U2 63 Harmonic Phase Angle	31256		T17
U3 Harmonic Data			
Base for % calculation	31257	31258	T5
U3 2 Harmonic Abs %	31259		T16
U3 2 Harmonic Phase Angle	31260		T17
U3 Harmonics from 3rd to 30th			
U3 63 Harmonic Abs %	31383		T16
U3 63 Harmonic Phase Angle	31384		T17

**Register table for the actual measurements**

Parameter	MODBUS		
	Register		Type
	Start	End	
Line voltage harmonic data			
U12 Harmonic Data			
Base for % calculation	31385	31386	T5
U12 1 Harmonic Abs %	31387		T16
U12 1 Harmonic Phase Angle	31388		T17
U12 Harmonics from 2 to 62			
U12 63 Harmonic Abs %	31511		T16
U12 63 Harmonic Phase Angle	31512		T17
U23 Harmonic Data			
Base for % calculation	31513	31514	T5
U23 1 Harmonic Abs %	31515		T16
U23 1 Harmonic Phase Angle	31516		T17
U23 Harmonics from 2 to 62			
U23 63 Harmonic Abs %	31639		T16
U23 63 Harmonic Phase Angle	31640		T17
U31 Harmonic Data			
Base for % calculation	31641	31642	T5
U31 2 Harmonic Abs %	31643		T16
U31 2 Harmonic Phase Angle	31644		T17
U31 Harmonics from 3rd to 30th			
U31 63 Harmonic Abs %	31767		T16
U31 63 Harmonic Phase Angle	31768		T17

**Register table for the actual measurements**

Parameter	MODBUS		
	Register		Type
	Start	End	
Phase current harmonic data			
I1 Harmonic Data			
Base for % calculation	31769	31770	T5
I1 1 Harmonic Abs %	31771		T16
I1 1 Harmonic Phase Angle	31772		T17
I1 Harmonics from 2 to 62			
I1 63 Harmonic Abs %	31895		T16
I1 63 Harmonic Phase Angle	31896		T17
I2 Harmonic Data			
Base for % calculation	31897	31898	T5
I2 1 Harmonic Abs %	31899		T16
I2 1 Harmonic Phase Angle	31900		T17
I2 Harmonics from 2 to 62			
I2 63 Harmonic Abs %	32023		T16
I2 63 Harmonic Phase Angle	32024		T17
I3 Harmonic Data			
Base for % calculation	32025	32026	T5
I3 2 Harmonic Abs %	32027		T16
I3 2 Harmonic Phase Angle	32028		T17
I3 Harmonics from 3rd to 30th			
I3 63 Harmonic Abs %	32151		T16
I3 63 Harmonic Phase Angle	32152		T17

**Register table for the actual measurements**

Parameter	MODBUS		
	Register		Type
	Start	End	
Phase voltage interharmonic data			
U1 Interharmonic Data			
Base for % calculation	32153	32154	T5
1. Interharmonic Abs %	32155		T16
2. Interharmonic Abs %	32156		T16
3. - 10 Interharmonic	32157	32164	T16
63 Interharmonic Abs %	36405	36466	T16
U2 Interharmonic Data			
Base for % calculation	32471	32472	T5
1. Interharmonic Abs %	32173		T16
2. Interharmonic Abs %	32174		T16
3. - 10 Interharmonic	32175	32182	T16
63 Interharmonic Abs %	36471	36532	T16
U3 Interharmonic Data			
Base for % calculation	32189	32190	T5
1. Interharmonic Abs %	32191		T16
2. Interharmonic Abs %	32192		T16
3. - 10 Interharmonic	32193	32200	T16
63 Interharmonic Abs %	36537	36598	T16
Phase to phase voltage interharmonic data			
U12 Interharmonic Data			
Base for % calculation	32417	32418	T5
1. Interharmonic Abs %	32419		T16
2. Interharmonic Abs %	32420		T16
3. - 10 Interharmonic	32421	32428	T16
63 Interharmonic Abs %	36603	36664	T16
U23 Interharmonic Data			
Base for % calculation	32435	32436	T5
1. Interharmonic Abs %	32437		T16
2. Interharmonic Abs %	32438		T16
3. - 10 Interharmonic	32439	32446	T16
63 Interharmonic Abs %	36669	36730	T16
U31 Interharmonic Data			
Base for % calculation	32453	32454	T5
1. Interharmonic Abs %	32455		T16
2. Interharmonic Abs %	32456		T16
3. - 10 Interharmonic	32457	32464	T16
63 Interharmonic Abs %	36735	36796	T16

All other MODBUS registers are a subject to change. For the latest MODBUS register definitions contact GE Vernova at [www.gevernova.com/grid-solutions/contact.htm](http://www.gevernova.com/grid-solutions/contact.htm).

**Register table for the basic settings**

Register	Content	Type	Ind	Values / Dependencies	Min	Max	Pass. Level
40143	Connection Mode	T1	0	No mode	1	5	2
			1	1b - Single Phase			
			2	3b - 3 phase 3 wire balanced			
			3	4b - 3 phase 4 wire balanced			
			4	3u - 3 phase 3 wire unbalanced			
			5	4u - 3 phase 4 wire unbalanced			
40144	CT Secondary	T4		mA			2
40145	CT Primary	T4		A/10			2
40146	VT Secondary	T4		mV			2
40147	VT Primary	T4		V/10			2
40148	Current input range (%)	T16		10000 for 100%	5,00	200,00	2
40149	Voltage input range (%)	T16		10000 for 100%	2,50	100,00	2
40150	Frequency nominal value	T1		Hz	10	1000	2

**Data types decoding**

Type	Bit mask	Description
T1		Unsigned Value (16 bit) Example: 12345 = 3039(16)
T2		Signed Value (16 bit) Example: -12345 = CFC7(16)
T3		Signed Long Value (32 bit) Example: 123456789 = 075B CD 15(16)
T4	bits # 15...14 bits # 13...00	Short Unsigned float (16 bit) Decade Exponent(Unsigned 2 bit) Binary Unsigned Value (14 bit) Example: 10000*102 = A710(16)
T5	bits # 31...24 bits # 23...00	Unsigned Measurement (32 bit) Decade Exponent(Signed 8 bit) Binary Unsigned Value (24 bit) Example: 123456*10-3 = FD01 E240(16)
T6	bits # 31...24 bits # 23...00	Signed Measurement (32 bit) Decade Exponent (Signed 8 bit) Binary Signed value (24 bit) Example: - 123456*10-3 = FDFE 1DC0(16)
T7	bits # 31...24 bits # 23...16 bits # 15...00	Power Factor (32 bit) Sign: Import/Export (00/FF) Sign: Inductive/Capacitive (00/FF) Unsigned Value (16 bit), 4 decimal places Example: 0.9876 CAP = 00FF 2694(16)
T9	bits # 31...24 bits # 23...16 bits # 15...08 bits # 07...00	Time (32 bit) 1/100s 00 - 99 (BCD) Seconds 00 - 59 (BCD) Minutes 00 - 59 (BCD) Hours 00 - 24 (BCD) Example: 15:42:03.75 = 7503 4215(16)

**Data types decoding**

Type	Bit mask	Description
T10	bits # 31...24 bits # 23...16 bits # 15...00	Date (32 bit) Day of month 01 - 31 (BCD) Month of year 01 - 12 (BCD) Year (unsigned integer) 1998..4095 Example: 10, SEP 2000 = 1009 07D0(16)
T16		Unsigned Value (16 bit), 2 decimal places Example: 123.45 = 3039(16)
T17		Signed Value (16 bit), 2 decimal places Example: -123.45 = CFC7(16)
T_float	bits # 31 bits # 31 bits # 31	IEEE 754 Floating-Point Single Precision Value (32bit) Sign Bit (1 bit) Exponent Field (8 bit) Significand (23 bit) Example: 123.45 stored as 123.45000 = 42F6 E666(16)
T_Str4		Text: 4 characters (2 characters for 16 bit register)
T_Str6		Text: 6 characters (2 characters for 16 bit register)
T_Str8		Text: 8 characters (2 characters for 16 bit register)
T_Str16		Text: 16 characters (2 characters for 16 bit register)
T_Str40		Text: 40 characters (2 characters for 16 bit register)

## APPENDIX B: DNP3 communication protocol

### Communication protocols

Modbus and DNP3 protocol are enabled via RS232 and RS485 or Ethernet communication. Both communication protocols are supported on all communication ports of ISTAT M365A/M365B. The response is the same type as the request.

### DNP3

DNP3 protocol enables operation of a device on DNP3 networks. For ISTAT M365A/M365B with serial communication the DNP3 protocol enables point to point (for example device to PC) communication via RS232 communication and multi drop communication via RS485.

ISTAT M365A/M365B automatically responses to MODBUS or DNP3 request.

#### PLEASE NOTE

For the latest and complete DNP3 table please visit [www.gevernova.com/grid-solutions/contact.htm](http://www.gevernova.com/grid-solutions/contact.htm)

DNP 3.0 Device Profile Document	Issue: E Date: 8 Jan 2013
Device Name: Measurement center Vendor Name: GE Vernova Models Covered: M365A/M365B	
Highest DNP Level Supported: For Requests: 1 For Responses: 1	Device Function: <input type="checkbox"/> Master <input checked="" type="checkbox"/> Slave
Notable objects, functions, and/or qualifiers supported in addition to the Highest DNP Levels Supported (the complete list is described in the DNP V3.0 Implementation table):	
Maximum Data Link Frame Size (octets): Transmitted: 292 Received: 249 Maximum Data Link Re-tries: <input checked="" type="checkbox"/> None <input type="checkbox"/> Configurable	Maximum Application Fragment Size (octets): Transmitted: 2048 Received: 249 Maximum Application Layer Re-tries: <input checked="" type="checkbox"/> None <input type="checkbox"/> Configurable
Requires Data Link Layer Confirmation: <input checked="" type="checkbox"/> Never <input type="checkbox"/> Always <input type="checkbox"/> Sometimes <input type="checkbox"/> Configurable	
Requires Application Layer Confirmation: <input checked="" type="checkbox"/> Never <input type="checkbox"/> Always <input type="checkbox"/> Sometimes <input type="checkbox"/> Configurable	

Timeouts while waiting for: Data Link Confirm: <input checked="" type="checkbox"/> <b>None</b> <input type="checkbox"/> Fixed at _____ <input type="checkbox"/> Variable <input type="checkbox"/> Configurable Complete Appl. Fragment: <input checked="" type="checkbox"/> <b>None</b> <input type="checkbox"/> Fixed at _____ <input type="checkbox"/> Variable <input type="checkbox"/> Configurable Application Confirm: <input checked="" type="checkbox"/> <b>None</b> <input type="checkbox"/> Fixed at _____ <input type="checkbox"/> Variable <input type="checkbox"/> Configurable Complete Appl. Response: <input checked="" type="checkbox"/> <b>None</b> <input type="checkbox"/> Fixed at _____ <input type="checkbox"/> Variable <input type="checkbox"/> Configurable Others:	
Sends/Executes Control Operations: WRITE Binary Outputs <input checked="" type="checkbox"/> <b>Never</b> <input type="checkbox"/> Always <input type="checkbox"/> Sometimes <input type="checkbox"/> Configurable SELECT/OPERATE <input checked="" type="checkbox"/> <b>Never</b> <input type="checkbox"/> Always <input type="checkbox"/> Sometimes <input type="checkbox"/> Configurable DIRECT OPERATE <input checked="" type="checkbox"/> <b>Never</b> <input type="checkbox"/> Always <input type="checkbox"/> Sometimes <input type="checkbox"/> Configurable DIRECT OPERATE – NO ACK <input checked="" type="checkbox"/> <b>Never</b> <input type="checkbox"/> Always <input type="checkbox"/> Sometimes <input type="checkbox"/> Configurable  Count > 1 <input checked="" type="checkbox"/> <b>Never</b> <input type="checkbox"/> Always <input type="checkbox"/> Sometimes <input type="checkbox"/> Configurable Pulse On <input checked="" type="checkbox"/> <b>Never</b> <input type="checkbox"/> Always <input type="checkbox"/> Sometimes <input type="checkbox"/> Configurable Pulse Off <input checked="" type="checkbox"/> <b>Never</b> <input type="checkbox"/> Always <input type="checkbox"/> Sometimes <input type="checkbox"/> Configurable Latch On <input checked="" type="checkbox"/> <b>Never</b> <input type="checkbox"/> Always <input type="checkbox"/> Sometimes <input type="checkbox"/> Configurable Latch Off <input checked="" type="checkbox"/> <b>Never</b> <input type="checkbox"/> Always <input type="checkbox"/> Sometimes <input type="checkbox"/> Configurable  Queue <input checked="" type="checkbox"/> <b>Never</b> <input type="checkbox"/> Always <input type="checkbox"/> Sometimes <input type="checkbox"/> Configurable Clear Queue <input checked="" type="checkbox"/> <b>Never</b> <input type="checkbox"/> Always <input type="checkbox"/> Sometimes <input type="checkbox"/> Configurable	
Reports Binary Input Change Events when no specific variation requested: <input checked="" type="checkbox"/> <b>Never</b> <input type="checkbox"/> Only non-time-tagged <input type="checkbox"/> Configurable	Reports time-tagged Binary Input Change Events when no specific variation requested: <input checked="" type="checkbox"/> <b>Never</b> <input type="checkbox"/> Binary Input Change With Relative Time <input type="checkbox"/> Configurable
Sends Unsolicited Responses: <input checked="" type="checkbox"/> <b>Never</b> <input type="checkbox"/> Configurable <input type="checkbox"/> Only certain Objects <input type="checkbox"/> Sometimes <input type="checkbox"/> ENABLE/DISABLE UNSOLICITED Function codes supported	Sends Static Data in Unsolicited Responses: <input checked="" type="checkbox"/> <b>Never</b> <input type="checkbox"/> When Device Restarts <input type="checkbox"/> When Status Flags Change  No other options are permitted.
Default Counter Object/Variation: <input type="checkbox"/> No Counters Reported <input type="checkbox"/> Configurable <input checked="" type="checkbox"/> <b>Default Object: 30</b> <input checked="" type="checkbox"/> <b>Default Variation: 4</b> <b>Point-by-point list attached</b>	Counters Roll Over at: <input type="checkbox"/> No Counters Reported <input type="checkbox"/> Configurable <input type="checkbox"/> 16 Bits <input type="checkbox"/> 32 Bits <input checked="" type="checkbox"/> <b>Other Value: 20000</b> <b>Point-by-point list attached</b>
Sends Multi-Fragment Responses: <input type="checkbox"/> Yes <input checked="" type="checkbox"/> <b>No</b>	

Object			Request			Response	
Object	Variation	Description	Function	Qualifier	Function	Qualifier	
Number	Number		Codes (dec)	Codes (hex)	Codes (dec)	Codes (hex)	
0	242	Device Attributes - software version	1	0	129	00, 17	
0	243	Device Attributes - hardware version	1	0	129	00, 17	
0	246	Device Attributes - user assigned ID	1	0	129	00, 17	
0	248	Device Attributes - serial number	1	0	129	00, 17	
0	250	Device Attributes - product name	1	0	129	00, 17	
0	252	Device Attributes - manufacture name	1	0	129	00, 17	
0	254	Device Attributes - nonspecific all attributes request	1	00, 06			
0	255	Device Attributes - list of attribute variation	1	00, 06	129	00, 5B	
Points for object 0							
0	Software version	T_Str3		Data	var	242	
0	Hardware version	T_Str2		Data	var	243	
0	user assigned ID	T_Str2		Data	var	246	
0	serial number	T_Str8		Data	var	248	
0	product name	T_Str16		Data	var	250	
0	manufacture name	T_Str20		Data	var	252	

Object			Request		Response	
Object	Variation	Description	Function	Qualifier	Function	Qualifier
Number	Number		Codes (dec)	Codes (hex)	Codes (dec)	Codes (hex)
10	0	Binary output status	1	00, 01, 06		
10	2	Binary output status	1	00, 01, 06	129	00, 01
Points for object 10						
0	Relay 1	T1	Data	0 1		
1	Relay 2	T1	Data	0 1		
2	Relay 3	T1	Data	0 1		
3	Relay 4	T1	Data	0 1		
4	Slot A - Relay 1	T1	Data	0 1		
5	Slot A - Relay 2	T1	Data	0 1		
6	Slot A - Relay 3	T1	Data	0 1		
7	Slot A - Relay 4	T1	Data	0 1		
8	Slot A - Relay 5	T1	Data	0 1		
9	Slot A - Relay 6	T1	Data	0 1		
10	Slot A - Relay 7	T1	Data	0 1		
11	Slot A - Relay 8	T1	Data	0 1		
12	Slot B - Relay 1	T1	Data	0 1		
13	Slot B - Relay 2	T1	Data	0 1		
14	Slot B - Relay 3	T1	Data	0 1		
15	Slot B - Relay 4	T1	Data	0 1		
16	Slot B - Relay 5	T1	Data	0 1		
17	Slot B - Relay 6	T1	Data	0 1		
18	Slot B - Relay 7	T1	Data	0 1		
19	Slot B - Relay 8	T1	Data	0 1		

Object			Request			Response	
Object	Variation	Description	Function	Qualifier	Function	Qualifier	
Number	Number		Codes (dec)	Codes (hex)	Codes (dec)	Codes (hex)	
30	0	16-Bit Analog Input without flag	1	00, 01, 06			
30	2	16-Bit Analog Input with flag	1	00, 01, 06	129	00, 01	
30	4	16-Bit Analog Input without flag	1	00, 01, 06	129	00, 01	
Points for object 30							
0	U1	T16	Data	-Un	+Un		
1	U2	T16	Data	-Un	+Un		
2	U3	T16	Data	-Un	+Un		
3	Uavg (phase to neutral)	T16	Data	-Un	+Un		
4	U12	T16	Data	-Un	+Un		
5	U23	T16	Data	-Un	+Un		
6	U31	T16	Data	-Un	+Un		
7	Uavg (phase to phase)	T16	Data	-Un	+Un		
8	I1	T16	Data	-In	+In		
9	I2	T16	Data	-In	+In		
10	I3	T16	Data	-In	+In		
11	I total	T16	Data	-In	+In		
12	I neutral (calculated)	T16	Data	-In	+In		
13	I neutral (measured)	T16	Data	-In	+In		
14	Iavg	T16	Data	-In	+In		
15	Active Power Phase L1 (P1)	T17	Data	-Pn	+Pn		
16	Active Power Phase L2 (P2)	T17	Data	-Pn	+Pn		
17	Active Power Phase L3 (P3)	T17	Data	-Pn	+Pn		
18	Active Power Total (Pt)	T17	Data	-Pt	+Pt		
19	Reactive Power Phase L1 (Q1)	T17	Data	-Pn	+Pn		
20	Reactive Power Phase L2 (Q2)	T17	Data	-Pn	+Pn		
21	Reactive Power Phase L3 (Q3)	T17	Data	-Pn	+Pn		
22	Reactive Power Total (Qt)	T17	Data	-Pt	+Pt		
23	Apparent Power Phase L1 (S1)	T16	Data	-Pn	+Pn		
24	Apparent Power Phase L2 (S2)	T16	Data	-Pn	+Pn		
25	Apparent Power Phase L3 (S3)	T16	Data	-Pn	+Pn		
26	Apparent Power Total (St)	T16	Data	-Pt	+Pt		
27	Power Factor Phase 1 (PF1)	T17	Data	-1	1		
28	Power Factor Phase 2 (PF2)	T17	Data	-1	1		
29	Power Factor Phase 3 (PF3)	T17	Data	-1	1		
Points for object 30 cont.							
30	Power Factor Total (PFt)	T17	Data	-1	1		
31	CAP/IND P. F. Phase 1 (PF1)	T17	Data	-1 CAP	+1	300% for -1 IND	
32	CAP/IND P. F. Phase 2 (PF2)	T17	Data	-1 CAP	+1	300% for -1 IND	
33	CAP/IND P. F. Phase 3 (PF3)	T17	Data	-1 CAP	+1	300% for -1 IND	
34	CAP/IND P. F. Total (PFt)	T17	Data	-1 CAP	+1	300% for -1 IND	
35	j1 (angle between U1 and I1)	T17	Data	-100°	+100°		
36	j2 (angle between U2 and I2)	T17	Data	-100°	+100°		
37	j3 (angle between U3 and I3)	T17	Data	-100°	+100°		
38	Power Angle Total (atan2(Pt,Qt))	T17	Data	-100°	+100°		
39	j 12 (angle between U1 and U2)	T17	Data	-100°	+100°		
40	j 23 (angle between U2 and U3)	T17	Data	-100°	+100°		
41	j 31 (angle between U3 and U1)	T17	Data	-100°	+100°		
42	Frequency	T17	Data	Fn-10Hz	Fn+10Hz		
43	U unbalance	T16	Data	-100%	100%		
44	I1 THD%	T16	Data	-100%	100%		
45	I2 THD%	T16	Data	-100%	100%		
46	I3 THD%	T16	Data	-100%	100%		
47	U1 THD%	T16	Data	-100%	100%		

48	U2 THD%	T16	Data	-100%	100%	
49	U3 THD%	T16	Data	-100%	100%	
50	U12 THD%	T16	Data	-100%	100%	
51	U23 THD%	T16	Data	-100%	100%	
52	U31 THD%	T16	Data	-100%	100%	
MAX DEMAND SINCE LAST RESET						
53	Active Power Total (Pt) - (positive)	T16	Data	-Pt	+Pt	
54	Active Power Total (Pt) - (negative)	T16	Data	-Pt	+Pt	
55	Reactive Power Total (Qt) - L	T16	Data	-Pt	+Pt	
56	Reactive Power Total (Qt) - C	T16	Data	-Pt	+Pt	
57	Apparent Power Total (St)	T16	Data	-Pt	+Pt	
58	I1	T16	Data	-In	+In	
59	I2	T16	Data	-In	+In	
60	I3	T16	Data	-In	+In	
DYNAMIC DEMAND VALUES						
61	Active Power Total (Pt) - (positive)	T16	Data	-Pt	+Pt	
62	Active Power Total (Pt) - (negative)	T16	Data	-Pt	+Pt	
63	Reactive Power Total (Qt) - L	T16	Data	-Pt	+Pt	
64	Reactive Power Total (Qt) - C	T16	Data	-Pt	+Pt	
65	Apparent Power Total (St)	T16	Data	-Pt	+Pt	
66	I1	T16	Data	-In	+In	
67	I2	T16	Data	-In	+In	
68	I3	T16	Data	-In	+In	
ENERGY						
	Energy Counter 1	T17	Data			(32-bit value) MOD 20000
	Energy Counter 2	T17	Data			(32-bit value) MOD 20000
	Energy Counter 3	T17	Data			(32-bit value) MOD 20000
	Energy Counter 4	T17	Data			(32-bit value) MOD 20000
	Energy Counter 1 Cost	T17	Data			(32-bit value) MOD 20000
	Energy Counter 2 Cost	T17	Data			(32-bit value) MOD 20000
	Energy Counter 3 Cost	T17	Data			(32-bit value) MOD 20000
	Energy Counter 4 Cost	T17	Data			(32-bit value) MOD 20000
	Total Energy Counter Cost	T17	Data			(32-bit value) MOD 20000
	Aktiv Tariff	T1	Data			
	Internal Temperature	T17	Data	-100°	+100°	

Object			Request		Response	
Object Number	Variation Number	Description	Function Codes (dec)	Qualifier Codes (hex)	Function Codes (dec)	Qualifier Codes (hex)
40	0		16-bit Analog output status	1	00, 01, 06	
40	2	16-bit Analog output status	1	00, 01, 06	129	00, 01
Points for object 40						
0	Analog output 1	T1	Data	0		
1	Analog output 2	T1	Data	0		
2	Analog output 3	T1	Data	0		
3	Analog output 4	T1	Data	0		
4	Slot A - Analog output 1	T1	Data	0		
5	Slot A - Analog output 2	T1	Data	0		
6	Slot A - Analog output 3	T1	Data	0		
7	Slot A - Analog output 4	T1	Data	0		
8	Slot B - Analog output 1	T1	Data	0		
9	Slot B - Analog output 2	T1	Data	0		
10	Slot B - Analog output 3	T1	Data	0		
11	Slot B - Analog output 4	T1	Data	0		

Object			Request		Response	
Object Number	Variation Number	Description	Function Codes (dec)	Qualifier Codes (hex)	Function Codes (dec)	Qualifier Codes (hex)
50	0		Time and Date - absolute time	2	7	
50	1	Time and Date - absolute time	2	7	129	7
Points for object 40						
0	Time and Date	T_Time	Data			

Object			Request		Response	
Object Number	Variation Number	Description	Function Codes (dec)	Qualifier Codes (hex)	Function Codes (dec)	Qualifier Codes (hex)
60	1		CLASS 0 DATA	1	6	
60	2	CLASS 1 DATA	1,22*	6		
60	3	CLASS 2 DATA	1,22*	6		
60	4	CLASS 3 DATA	1,22*	6		

\*only object 30

## APPENDIX C: Equations

Definitions of symbols

No	Symbol	Definition
1	MP	Average interval
2	U <sub>f</sub>	Phase voltage (U <sub>1</sub> , U <sub>2</sub> or U <sub>3</sub> )
3	U <sub>ff</sub>	Phase-to-phase voltage (U <sub>12</sub> , U <sub>23</sub> or U <sub>31</sub> )
4	N	Total number of samples in a period
5	n	Sample number (0 ≤ n ≤ N)
6	x, y	Phase number (1, 2 or 3)
7	i <sub>n</sub>	Current sample n
8	u <sub>fn</sub>	Phase voltage sample n
9	u <sub>fFn</sub>	Phase-to-phase voltage sample n
10	φ <sub>r</sub>	Power angle between current and phase voltage f ( φ, φ or φ )
11	U <sub>u</sub>	Voltage unbalance
12	U <sub>c</sub>	Agreed supply voltage

## Voltage

$$U_f = \sqrt{\frac{\sum_{n=1}^N u_n^2}{N}}$$

### Phase voltage

N – samples in averaging interval (up to 65 Hz)

$$U_{xy} = \sqrt{\frac{\sum_{n=1}^N (u_{xn} - u_{yn})^2}{N}}$$

### Phase-to-phase voltage

$u_x, u_y$  – phase voltages ( $U_f$ )

N – a number of samples in averaging interval

$$U_u = \sqrt{\frac{1 - \sqrt{3 - 6\beta}}{1 + \sqrt{3 - 6\beta}}} \cdot 100\%$$

### Voltage unbalance

$U_{fund}$  – first harmonic of phase-to-phase voltage

$$\beta = \frac{U_{12fund}^4 + U_{23fund}^4 + U_{31fund}^4}{(U_{12fund}^2 + U_{23fund}^2 + U_{31fund}^2)^2}$$

$$U_{POS} = \frac{1}{3} \left| U_{L1,fund} + U_{L2,fund}^{120^\circ} + U_{L3,fund}^{240^\circ} \right|$$

### Positive voltage sequence

$U_{fund}$  – first harmonic of phase voltage

$$U_{NEG} = \frac{1}{3} \left| U_{L1,fund} + U_{L2,fund}^{-120^\circ} + U_{L3,fund}^{-240^\circ} \right|$$

### Negative voltage sequence

$U_{fund}$  – first harmonic of phase voltage

$$U_{ZERO} = \frac{1}{3} \left| U_{L1,fund} + U_{L2,fund} + U_{L3,fund} \right|$$

### Zero voltage sequence

$U_{fund}$  – first harmonic of phase voltage

## Current

$$I_{RMS} = \sqrt{\frac{\sum_{n=1}^N i_n^2}{N}}$$

### Phase current

N – samples in averaging interval (up to 65 Hz)

$$I_n = \sqrt{\frac{\sum_{n=1}^N (i_{1n} + i_{2n} + i_{3n})^2}{N}}$$

### Neutral current

$i$  – n sample of phase current (1, 2 or 3)

N – samples in averaging interval (up to 65 Hz)

## Power

$P_f = \frac{1}{N} \cdot \sum_{n=1}^N (u_{fn} \cdot i_{fn})$	<p><b>Active power by phases</b>            N – a number of periods            n – index of sample in a period            f – phase designation</p>
$P_t = P_1 + P_2 + P_3$	<p><b>Total active power</b>            t – total power            1, 2, 3 – phase designation</p>
<p><b>Sign<math>Q_f(\varphi)</math></b>  <math>\varphi \in [0^\circ - 180^\circ] \Rightarrow \text{Sign}Q_f(\varphi) = +1</math>  <math>\varphi \in [180^\circ - 360^\circ] \Rightarrow \text{Sign}Q_f(\varphi) = -1</math></p>	<p><b>Reactive power sign</b>  <math>Q_f</math> – reactive power (by phases)  <math>\varphi</math> – power angle</p>
$S_f = U_f \cdot I_f$	<p><b>Apparent power by phases</b>  <math>U_f</math> – phase voltage  <math>I_f</math> – phase current</p>
$S_t = S_1 + S_2 + S_3$	<p><b>Total apparent power</b>  <math>S_t</math> – apparent power by phases</p>
$Q_f = \text{Sign}Q_f(\varphi) \cdot \sqrt{S_f^2 - P_f^2}$	<p><b>Reactive power by phases</b>  <math>S_f</math> – apparent power by phases  <math>P_f</math> – active power by phases</p>
$Q_f = \frac{1}{N} \cdot \sum_{n=1}^N (u_{fn} \times i_{f[n+N/4]})$	<p><b>Reactive power by phases (displacement method)</b>            N – a number of samples in a period            n – sample number (<math>0 \leq n \leq N</math>)            f – phase designation</p>
$Q_t = Q_1 + Q_2 + Q_3$	<p><b>Total reactive power</b>  <math>Q_t</math> – reactive power by phases</p>
$D = \sqrt{S^2 - P^2 - Q_{fund}^2}$	<p><b>Distortion power</b>            S – Apparent power            P – Active power  <math>Q_{fund}</math> – Fundamental reactive power</p>
$Q_{fund} = \text{Im}\{DFT[u \times i]\}$	<p><b>Fundamental reactive power</b>            Imaginary part of first harmonic part of momentary voltage and current product</p>
<p><math>\varphi_s = \arctan 2(P_t, Q_t)</math>  <math>\varphi_s = [-180^\circ, 179,99^\circ]</math></p>	<p><b>Total power angle</b>  <math>P_t</math> – total active power  <math>Q_t</math> – total reactive power</p>
$PF = \frac{ P }{S}$	<p><b>Distortion power factor</b>            P – active power            S – apparent power</p>

$$dPF = \frac{P_1}{S_1}$$

**Displacement power factor**P<sub>1</sub> – Fundamental active powerS<sub>1</sub> – Fundamental apparent power**THD, TDD**

$$I_f THD(\%) = \frac{\sqrt{\sum_{n=2}^{63} I_n^2}}{I_1} \cdot 100$$

**Current THD**I<sub>1</sub> – value of first harmonic

n – number of harmonic

$$I_f TDD(\%) = \frac{\sqrt{\sum_{n=2}^{63} I_n^2}}{I_L} \cdot 100$$

**Current TDD**I<sub>L</sub> – value of max. load current (fixed, user defined value)

n – number of harmonic

$$U_f THD(\%) = \frac{\sqrt{\sum_{n=2}^{63} U_{fn}^2}}{U_{f1}} \cdot 100$$

**Phase voltage THD**U<sub>1</sub> – value of first harmonic

n – number of harmonic

$$U_{ff} THD(\%) = \frac{\sqrt{\sum_{n=2}^{63} U_{ffn}^2}}{U_{ff1}} \cdot 100$$

**Phase-to-phase voltage THD**U<sub>1</sub> – value of first harmonic

n – number of harmonic

**Current factors**

$$CFI(\%) = \frac{I_{PEAK}}{I_{RMS}} \cdot 100$$

**CREST factor**I<sub>RMS</sub> – RMS value of phase currentI<sub>PEAK</sub> – Peak value of current within cycle

$$K_i = \frac{\sum_{n=1}^{63} (I_n \times n)^2}{\sum_{n=1}^{63} I_n^2}$$

**K factor**

n – number of harmonic

## Flickers

---

$$P_{50S} = (P_{30} + P_{50} + P_{80})/3$$

$$P_{10S} = (P_6 + P_8 + P_{10} + P_{13} + P_{17})/5$$

$$P_{3S} = (P_{2,2} + P_3 + P_4)/3$$

$$P_{1S} = (P_{1,7} + P_1 + P_{1,5})/3$$

$$P_{st} = \sqrt{0,0314P_{0,1} + 00525P_{1S} + 0,0657P_{3S} + 0,28P_{10S} + 0,08P_{50S}}$$

### Pst – Short-term flicker intensity

Short-term flicker intensity is measured in 10 minute periods.

**Px** – flicker levels that are exceeded by x% in a 10-minute period (e.g. P<sub>0,1</sub> represents a flicker level that is exceeded by 0.1% samples)

$$P_{lt} = \sqrt[3]{\sum_{i=1}^{12} \frac{P_{sti}^3}{12}}$$

### Plt – Long-term flicker intensity

Calculated from twelve successive values of short-term flicker intensity in a two-hour period

---

## Energy

---

Price in tariff = Price · 10<sup>Tarif price exponent</sup>

Total exponent of tariff price and energy price in all tariffs

---

## APPENDIX D: PQDIF and COMTRADE recorder data storage organization

All PQDIF and COMTRADE file records which are created on ISTAT M365A/M365B are stored in a predefined folder in a logical hierarchy which is shown in the table below. Apart from this, table below also gives trigger names, trigger IDs, Record group IDs and subgroup IDs which cause these records to be created.

Trigger_Name	Trigger_ID	Record folder	Record Group_ID	Record SubGroup_ID
Trend recorder 1	TrLog_01	\Log_Trend\Recorder_01	TrLog	Rec_01
Trend recorder 2	TrLog_02	\Log_Trend\Recorder_02	TrLog	Rec_02
Trend recorder 3	TrLog_03	\Log_Trend\Recorder_03	TrLog	Rec_03
Trend recorder 4	TrLog_04	\Log_Trend\Recorder_04	TrLog	Rec_04
PQ Recorder	PQLog	\Log_PQ	PQLog	
Transient trigger Current	TrgTrC	\Trg_Transient\Current	TrgTr	Curr
Transient trigger Voltage	TrgTrV	\Trg_Transient\Voltage	TrgTr	Volt
PQ trigger Dip	TrgPqDip	\Trg_PQ\Dip	TrgPq	Dip
PQ trigger Inrush	TrgPqInrush	\Trg_PQ\Inrush	TrgPq	Inrush
PQ trigger Interruption	TrgPqInter	\Trg_PQ\Interruption	TrgPq	Inter
PQ trigger End Interruption	TrgPqInterEnd	\Trg_PQ\InterruptionEnd	TrgPq	InterEnd
PQ trigger RVC	TrgPqRvc	\Trg_PQ\Rvc	TrgPq	Rvc
PQ trigger Swell	TrgPqSwell	\Trg_PQ\Swell	TrgPq	Swell
Digital trigger 1	TrgDig01	\Trg_External\Digital_01	TrgExt	Dig_01
Digital trigger 2	TrgDig02	\Trg_External\Digital_02	TrgExt	Dig_02
Digital trigger 3	TrgDig03	\Trg_External\Digital_03	TrgExt	Dig_03
Digital trigger 4	TrgDig04	\Trg_External\Digital_04	TrgExt	Dig_04
Digital trigger 5	TrgDig05	\Trg_External\Digital_05	TrgExt	Dig_05
Digital trigger 6	TrgDig06	\Trg_External\Digital_06	TrgExt	Dig_06
Digital trigger 7	TrgDig07	\Trg_External\Digital_07	TrgExt	Dig_07
Digital trigger 8	TrgDig08	\Trg_External\Digital_08	TrgExt	Dig_08
Ethernet trigger 1	TrigEth01	\Trg_External\Ethernet_01	TrgExt	Eth_01
Ethernet trigger 2	TrigEth02	\Trg_External\Ethernet_02	TrgExt	Eth_02
Ethernet trigger 3	TrigEth03	\Trg_External\Ethernet_03	TrgExt	Eth_03
Ethernet trigger 4	TrigEth04	\Trg_External\Ethernet_04	TrgExt	Eth_04
Ethernet trigger 5	TrigEth05	\Trg_External\Ethernet_05	TrgExt	Eth_05
Ethernet trigger 6	TrigEth06	\Trg_External\Ethernet_06	TrgExt	Eth_06
Ethernet trigger 7	TrigEth07	\Trg_External\Ethernet_07	TrgExt	Eth_07
Ethernet trigger 8	TrigEth08	\Trg_External\Ethernet_08	TrgExt	Eth_08
Combined trigger 1	TrigCmb01	\Trg_Combined\Combined_01	TrgCmb	Cmb_01
Combined trigger 2	TrigCmb02	\Trg_Combined\Combined_02	TrgCmb	Cmb_02
Combined trigger 3	TrigCmb03	\Trg_Combined\Combined_03	TrgCmb	Cmb_03
Combined trigger 4	TrigCmb04	\Trg_Combined\Combined_04	TrgCmb	Cmb_04
Combined trigger 5	TrigCmb05	\Trg_Combined\Combined_05	TrgCmb	Cmb_05
Combined trigger 6	TrigCmb06	\Trg_Combined\Combined_06	TrgCmb	Cmb_06
Combined trigger 7	TrigCmb07	\Trg_Combined\Combined_07	TrgCmb	Cmb_07
Combined trigger 8	TrigCmb08	\Trg_Combined\Combined_08	TrgCmb	Cmb_08
Combined trigger 9	TrigCmb09	\Trg_Combined\Combined_09	TrgCmb	Cmb_09
Combined trigger 10	TrigCmb10	\Trg_Combined\Combined_10	TrgCmb	Cmb_10
Combined trigger 11	TrigCmb11	\Trg_Combined\Combined_11	TrgCmb	Cmb_11
Combined trigger 12	TrigCmb12	\Trg_Combined\Combined_12	TrgCmb	Cmb_12
Combined trigger 13	TrigCmb13	\Trg_Combined\Combined_13	TrgCmb	Cmb_13
Combined trigger 14	TrigCmb14	\Trg_Combined\Combined_14	TrgCmb	Cmb_14
Combined trigger 15	TrigCmb15	\Trg_Combined\Combined_15	TrgCmb	Cmb_15
Combined trigger 16	TrigCmb16	\Trg_Combined\Combined_16	TrgCmb	Cmb_16

A further explanation to the group and subgroup IDs are stated in the two tables below:

Record Group_ID	Description - Group_Name_En
TrLog	Trend recorder logs
PQLog	PQ recorder logs
TrgTr	Transient trigger events
TrgPq	PQ trigger events
TrgExt	External trigger events
TrgCmb	Combined trigger events

Record SubGroup_ID	Description - Group_Name_En
Rec_N	Recorder N
Curr	Current
Volt	Voltage
Dip	Dip
Inrush	Inrush current
Inter	Interruption
InterEnd	End Interruption
Rvc	RVC
Swell	Swell
Dig_N	Digital N
Eth_N	Ethernet N
Cmb_N	Combined N

All this file records are easily available from the device by means of FTP connection. Depending on FTP account permissions, the user can manipulate the stored data. The default read-only ftp account is user: "ftp"/pass: "ftp"

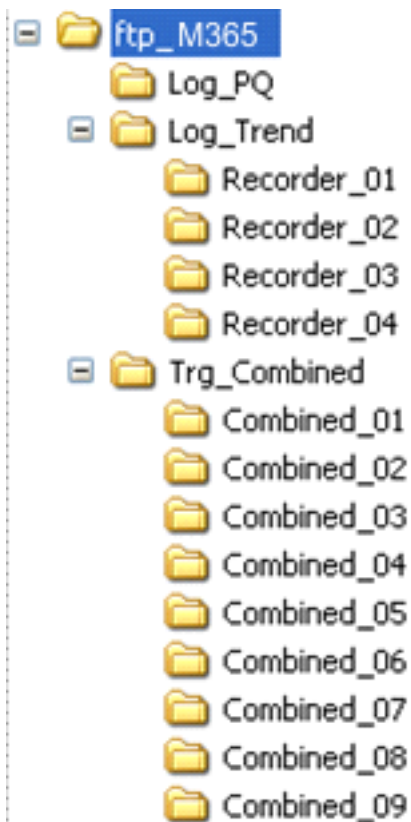

## PQDIF AND COMTRADE FILE NAMING CONVENTION

File names are determined according to the ISO standard 8601 standard.  
There are a few examples below:

### Fast Trend recorders (Recorder 1-4, PQ Recorder)

- these are created periodically with a predefined period  
Date: 26.3.2014  
Time: 00:00:00  
Abbreviations: z = UTC time, T = date - time separator

Example: 20142603T000000z.pqd

### Event recorders

- Here many events can occur within one seconds so milliseconds are used

Example:20142603T000000.046z.pqd

- If all records cannot be stored in one single file the recorder signature is added at the end of file name:

_T	Transient recorder
_W	Waveform recorder
_D	Disturbance recorder

Example:20142603T000000.046z\_**T**.pqd

Example:20142603T000000.046z\_**W**.pqd

Example:20142603T000000.046z\_**D**.pqd

## APPENDIX E: IEC61850 Ed.2 protocol support overview

### Overview

This appendix describes the scope of support for the IEC61850 Ed.2 protocol within ISTAT M365A/M365B. It provides the functionality overview as well as all the necessary means on how the configuration can be done.

### Basic implementation facts

- The Model Implementation Conformance Statement (MICS) for IEC61850 support is defined in IEC 61850-7-3 and IEC61850-7-4
- IEC61850 support is a SW-enabled optional feature
- Up to 8 preconfigured report datasets
- Up to 4 simultaneous IEC61850 client connections

### IEC61850 Ed.2 configuration

For every IEC61850 there should be a related ICD and CID configuration files. The implementation in ISTAT M365A/M365B has the following characteristics:

- Only one single ICD file corresponds to all HW variants of ISTAT M365A/M365B – this file corresponds to all available options within the instrument. This file is available via: [www.gegridsolutions.com/contact](http://www.gegridsolutions.com/contact)
- A predefined CID file is provided with every device with the IEC61850 server feature enabled and is the same as the publicly available ICD file. The file resides in ISTAT M365A/M365B file system in the /IEC61850/ folder so any user can optionally reconfigure the device through standard FTP communication channel if required by making the (re)configuration of the CID file and uploading and overwriting the existing CID file – file location. When reconfiguring the CID file we recommend to stick to the limits defined within this appendix.
- Any XML editor or 3rd party IEC61850 configuration tool can be used for reconfiguring the CID files

## Logical nodes supported in ISTAT M365A/M365B implementation of IEC61850 Ed.2

A general standard support scope overview is given in the table below:

	Logical node	Description
SYSTEM related nodes	LPHD - Physical device information	Physical device. Contains information related to the physical device. Only one instance of this node can be defined.
	LLN0 - Logical node zero	Logical node zero. Contains the data related to the associated IED. Only one instance of this node can be defined.
MEASUREMENT related nodes	MMXU - Measurements	Measurements. Contains per-phase and total current, voltage and power flow for operational purposes.
	AVGMMXU - Metering Statistics Average	Metering statistics. Consists of average, min and max for metered (MMXU) data.
	MAXMMXU - Metering Statistics Maximum	
	MINMMXU - Metering Statistics Minimum	
	MSQI - Sequence and imbalance	Sequence. Consists of sequence values for three/multi-phase power systems via symmetrical components
	MMTR - Metering	Metering. Consists of the integrated values (energy), primarily for billing purposes.
	GGIO - Generic process I/O	Generic process HW I/O module current statuses which include (depending on device HW variant): 4 analog inputs 4 general indication I/Os 8 bit Slot A 8 bit Slot B Current status of 32 SW configurable alarms which are programmed into the device.
	GGIO - Commands	Sending commands into M365B: Energy counters reset Min/Max measurements reset (affects statistic) Output relay ON/OFF (Output 1-4, Slot A)
	MHAI - Harmonics	Harmonics. Consists of voltage and current harmonic values as well as THD, K factor, Crest factor.
RDRE - Disturbance recorder function	Disturbance Recorder Function. Indicates to a client that a new PQDIF or COMTRADE file has been created in one of the device recorders and is available for transfer.	

## IEC61850 Ed.2 Data Sets in ISTAT M365A/M365B

Datasets are configured using any IEC 61850 configuration tool. One can have up to 8 datasets containing a maximum of 256 data values each. If this limit is exceeded, the resulting CID file will not function. Data sets must be located in LLN0 so that they can contain data from any logical node within that logical device. The ICD file for ISTAT M365A/M365B is preconfigured with eight default datasets and can be reconfigured by the user if required:

Dataset	Description
LPHD	Status dataset
MMXU	Measurements dataset
MSTA	Statistics dataset
MMTR	Metering dataset
GGIO	Inputs and outputs dataset
MHAI	Power quality dataset
MSQI	Sequence dataset
RDRE	Recorded files of all record types

## IEC61850 Ed.2 Reports in ISTAT M365A/M365B

Reports can be configured using any IEC 61850 configuration tool. Reports will only be transmitted to the client if that client has enabled the report. Reports must be located in LLN0 so that they can contain any dataset.

Dataset	Buffered/Unbuffered	Description
Device status	Unbuffered	Report containing status dataset (LPHD)
Measurements	Unbuffered	Report containing measurements dataset (MMXU)
Statistics	Unbuffered	Report containing statistics dataset (MSTA)
Energy	Unbuffered	Report containing metering dataset (MMTR)
Inputs and outputs	Unbuffered	Report containing inputs and outputs dataset (GGIO)
Imbalances	Unbuffered	Report containing sequence dataset (MSQI)

## Configuring Reporting Triggers

Reporting triggers allow ISTAT M365A/M365B automatically generate and send reports to clients when certain conditions are met. They are configured using any IEC 61850 configuration tool. The most commonly-used triggers are:

Trigger Option	Description	Default setting in M365B CID file
dchg (data-change)	Report is triggered when there is a change in value of a member of the data set. This data change must be greater than the deadband value configured in CID file.	Disabled
Integrity period	Report is triggered at regular, periodic intervals.	Enabled (4000 msec)
Quality changed	Report is triggered when quality is changed. Quality is part of every parameter within the CID file.	Disabled
GI (general interrogation)	Report is triggered upon client request.	Enabled
Data update	Only used for frozen counters	Disabled

## Model Implementation Conformance Statement

The model implementation conformance statement according to IEC 61850-7-3 and IEC 61850-7-4, is listed below:

Attribute name	Explanation	Attribute Type	Modbus Start	Modbus End
<b>LPHD - Physical device information</b>				
PhyNam	Physical device name plate	DPL	20001	20020
			20021	
			20022	
			20025	20028
			20029	20036
PhyHealth	Physical device health	INS		
Proxy	Indicates if this LN is a proxy	SPS		
<b>LLN0 - Logical node zero</b>				
Mod	Mode	INC	20051	
Beh	Behaviour	INS	20052	
Health	Health	INS	20053	
NamPlt	Name plate	LPL	20001	20020
<b>RDRE - Disturbance recorder function</b>				
RcdMade	Recording made	SPS	20101	
		SPS	20102	
FitNum	Fault Number	INS	20111	
<b>MMXU - Measurements</b>				
TotW	Total Active Power (Total P)	MV	21001	21002
TotVAr	Total Reactive Power (Total Q)	MV	21003	21004
TotVA	Total Apparent Power (Total S)	MV	21005	21006
TotPF	Average Power factor (Total PF)	MV	21007	21008

Attribute name	Explanation	Attribute Type	Modbus Start	Modbus End
<b>MMXU - Measurements</b>				
PPV	Phase to phase voltages, including angles	DEL	21011	21012
		DEL	21013	21014
		DEL	21015	21016
		DEL	21017	21018
		DEL	21019	21020
		DEL	21021	21022
PhV	Phase to ground voltages, including angles	WYE	21023	21024
		WYE	21025	21026
		WYE	21027	21028
		WYE	21029	21030
		WYE	21031	21032
A	Phase currents, including power angles	WYE	21033	21034
		WYE	21037	21038
		WYE	21039	21040
		WYE	21041	21042
		WYE	21043	21044
		WYE	21045	21046
		WYE	21049	21050
		WYE	21053	21054
		WYE	21055	21056
VAr	Phase reactive power (Q)	WYE	21057	21058
		WYE	21059	21060
		WYE	21061	21062
VA	Phase apparent power (S)	WYE	21063	21064
		WYE	21065	21066
		WYE	21067	21068
PF	Phase power factor (PF)	WYE	21069	21070
		WYE	21071	21072
		WYE	21073	21074
<b>MMXU - Metering Statistics Average</b>				
AvW	Average real power	MV	21075	21076
AvVAr	Average reactive power	MV	21081	21082
AvVA	Average apparent power	MV	21087	21088
<b>MMXU - Metering Statistics Maximum</b>				
MaxW	Maximum real power	MV	21077	21078
MaxVAr	Maximum reactive power	MV	21083	21084
MaxVA	Maximum apparent power	MV	21089	21090
<b>MMXU - Metering Statistics Minimum</b>				
MinW	Minimum real power	MV	21079	21080
MinVAr	Minimum reactive power	MV	21085	21086
MinVA	Minimum apparent power	MV	21091	21092
<b>MSQI - Sequence and imbalance</b>				
ImbNgV	Imbalance negative sequence voltage	MV	21093	21094
ImbZroV	Imbalance zero sequence voltage	MV	21095	21096
<b>MMTR - Metering</b>				
TotWh	Net Real energy since last reset	BCR	21097	21098
TotVArh	Net Reactive energy since last reset	BCR	21099	21100
TotVAh	Net Apparent energy since last reset	BCR	21101	21102
SupWh	Real energy supply (default supply direction: energy flow towards busbar)	BCR	21103	21104
SupVArh	Reactive energy supply (default supply direction: energy flow towards busbar)	BCR	21105	21106
DmdWh	Real energy demand (default demand direction: energy flow from busbar away)	BCR	21107	21108
DmdVArh	Reactive energy demand (default demand direction: energy flow from busbar away)	BCR	21109	21110

Attribute name	Explanation	Attribute Type	Modbus Start	Modbus End
<b>GGIO - Generic process I/O</b>				
AnIn_1	Analog input 1	MV	21111	21112
AnIn_2	Analog input 2	MV	21113	21114
AnIn_3	Analog input 3	MV	21115	21116
AnIn_4	Analog input 4	MV	21117	21118
Ind_1	General indication (input/output) 1	SPC	21119	
Ind_2	General indication (input/output) 2	SPC	21120	
Ind_3	General indication (input/output) 3	SPC	21121	
Ind_4	General indication (input/output) 4	SPC	21122	
IntIn_A	Integer status - Slot A	INS	21123	21124
IntIn_B	Integer status - Slot B	INS	21125	21126
ISCSO	Integer status - Alarms	INS	21127	21128
<b>GGIO - Commands</b>				
Reset	Energy Counters	SPC	41801	On=1, Off=0
Reset	Min/Max measurements	SPC	41802	On=1, Off=0
Output 1	Relay ON/OFF	SPC	41803	On=1, Off=0
Output 2	Relay ON/OFF	SPC	41804	On=1, Off=0
Output 3	Relay ON/OFF	SPC	41805	On=1, Off=0
Output 4	Relay ON/OFF	SPC	41806	On=1, Off=0
Output A1	Relay ON/OFF	SPC	41807	On=1, Off=0
Output A2	Relay ON/OFF	SPC	41808	On=1, Off=0
Output A3	Relay ON/OFF	SPC	41809	On=1, Off=0
Output A4	Relay ON/OFF	SPC	41810	On=1, Off=0
Output A5	Relay ON/OFF	SPC	41811	On=1, Off=0
Output A6	Relay ON/OFF	SPC	41812	On=1, Off=0
Output A7	Relay ON/OFF	SPC	41813	On=1, Off=0
Output A8	Relay ON/OFF	SPC	41814	On=1, Off=0

Attribute name	Explanation	Attribute Type	Modbus Start	Modbus End
<b>MHAI - Harmonics</b>				
Hz	Basic frequency	MV	21151	21152
HA	Sequence of harmonics current	HWYE	21153	21154
		HWYE	21155	21156
		HWYE	21405	21406
		HWYE	21407	21408
		HWYE	21657	21658
		HWYE	21659	21660
HPhV	Sequence of harmonics phase to ground voltages	HWYE	21909	21910
		HWYE	21911	21912
		HWYE	22161	22162
		HWYE	22163	22164
		HWYE	22413	22414
		HWYE	22415	22416
HPPV	Sequence of harmonics phase to phase voltages	HDEL	22665	22666
		HDEL	22667	22668
		HDEL	22917	22918
		HDEL	22919	22920
		HDEL	23169	23170
		HDEL	23171	23172
HKf	K factor	WYE	23421	23422
		WYE	23423	23424
		WYE	23425	23426
ThdA	Current total harmonic distortion	WYE	23427	23428
		WYE	23429	23430
		WYE	23431	23432
ThdPhV	Phase to ground voltage total harmonic distortion	WYE	23433	23434
		WYE	23435	23436
		WYE	23437	23438
ThdPPV	Phase to phase voltage total harmonic distortion	DEL	23439	23440
		DEL	23441	23442
		DEL	23443	23444
TddA	Current Total Demand Distortion	WYE	23445	23446
		WYE	23447	23448
		WYE	23449	23450
HCfA	Current crest factors	WYE	23451	23452
		WYE	23453	23454
		WYE	23455	23456

Preconfigured datasets	
STATUS	Status dataset
MMXU	Measurements dataset
AVGMMUX	Statistics dataset
MAXMMUX	Statistics dataset
MINMMUX	Statistics dataset
MMTR	Metering dataset
GGIO	Inputs and outputs dataset
MHAI	Power quality dataset
MSQI	Sequence dataset
RDRE	Recorder dataset
Preconfigured reports	
Device status	Contains Status dataset (STATUS)
Measurements	Contains Measurements dataset (MMXU)
Metering Statistics Average	Contains Statistics dataset (AVGMMUX)
Metering Statistics Maximum	Contains Statistics dataset (MAXMMUX)
Metering Statistics Minimum	Contains Statistics dataset (MINMMUX)
Energy	Contains Metering dataset (MMTR)
Inputs and outputs	Contains Inputs and outputs dataset (GGIO)
Imbalances	Contains Sequence dataset (MSQI)

## Appendix F: Cortec

M365	DISPLAY	NOMINAL FREQUENCY	POWER SUPPLY	COMMS	I/O MODULE 1/2	I/O MODULE 3/4	I/O MODULE A	I/O MODULE B	DESCRIPTION
M365	A								0A STAT M365A EN50160 PQ Analyser - TFT 5.7" display
	B								0A STAT M365B EN50160 PQ Analyser - Graphic 128x64 pixel display
		S							50/60 Hz
		A							400 Hz
			H						Universal High (80 ... 300 VDC, 80 ... 276 VAC)
				E					Ethernet (RJ45) + USB 2.0 (type B) - Modbus, DNP, FTP
				S					Ethernet (RJ45) + USB 2.0 (type B) - Modbus, DNP, FTP, IEC 61850
					A	A			2 x Analogue output (0 ... 20 mA)
					S	S			2 x Pulse output (40 Vac/dc @ 30 mA Max)
					M	M			2 x Relay (alarm output) (230 Vac/dc $\pm$ 20% @ 1 A Max)
					B	B			Bistable alarm output
					C	C			2 x Analogue Input - current (-20 ... 0 ... 20 mA)
					U	U			2 x Analogue Input - voltage (-10 ... 0 ... 10 V)
					R	R			2 x Analogue input - resistance (Pt100 - Pt1000)
					D	D			2 x Digital Input (230 Vac/dc $\pm$ 20%)
					E	E			2 x Digital Input (110 Vac/dc $\pm$ 20%)
					F	F			2 x Digital Input (5 ... 48 Vdc)
					P	P			2 x Pulse input (5 ... 48 VDC)
					T				2 x Tariff Input (230 Vac/dc $\pm$ 20%)
					Z				2 x Tariff Input (110 Vac/dc $\pm$ 20%)
					Y				2 x Tariff Input (5 ... 48 Vdc)
					W				1 x Watchdog + 1 x Relay (alarm) output (230 Vac/dc $\pm$ 20% @ 1 A Max)
					N	N			Not Fitted
							M		8 x Relay (alarm output) (230 Vac/dc $\pm$ 20% @ 100 mA Max)
							D	D	8 x Digital Input (230 Vac/dc $\pm$ 20%)
							E	E	8 x Digital Input (110 Vac/dc $\pm$ 20%)
							F	F	8 x Digital Input (5 ... 48 dc)
)							N	N	Not Fitted





GE VERNOVA

GE Vernova  
St Leonards Building  
Redhill Business Park  
Stafford, ST16 1WT, UK  
+44 (0) 1785 250 070  
[www.governova.com/grid-solutions/contact.htm](http://www.governova.com/grid-solutions/contact.htm)

© 2025 GE Vernova. All rights reserved. Information contained in this document is indicative only.  
No representation or warranty is given or should be relied on that it is complete or correct or will apply to any particular project.  
This will depend on the technical and commercial circumstances. It is provided without liability and is subject to change without  
notice. Reproduction, use or disclosure to third parties, without express written authority, is strictly prohibited.

M365A/B-TM-EN-1