



GE VERNOVA

Multilin™ EPM 9900P

High Performance Power Quality Metering System



Instruction Manual

Firmware Revision: 20.0000

Manual Part Number: 1601-0240-A3



Copyright © 2025 GE VERNOVA Multilin. All rights reserved.

Multilin™ EPM 9900P Instruction Manual for firmware revision 20.0000.

The contents of this manual are the property of GE VERNOVA Multilin. This documentation is furnished on license and may not be reproduced in whole or in part without the permission of GE VERNOVA Multilin. The manual is for informational use only and is subject to change without notice.

Part number: 1601-0240-A3 (January 2022)

CAUTION

GENERAL SAFETY PRECAUTIONS - EPM 9900P

- Failure to observe and follow the instructions provided in the equipment manual(s) could cause irreversible damage to the equipment and could lead to property damage, personal injury and/or death.
- Before attempting to use the equipment, it is important that all danger and caution indicators are reviewed.
- If the equipment is used in a manner not specified by the manufacturer or functions abnormally, proceed with caution. Otherwise, the protection provided by the equipment may be impaired and can result in Impaired operation and injury.
- Caution: Hazardous voltages can cause shock, burns or death.
- Installation/service personnel must be familiar with general device test practices, electrical awareness and safety precautions must be followed.
- Before performing visual inspections, tests, or periodic maintenance on this device or associated circuits, isolate or disconnect all hazardous live circuits and sources of electric power.
- Failure to shut equipment off prior to removing the power connections could expose you to dangerous voltages causing injury or death.
- All recommended equipment that should be grounded and must have a reliable and un-compromised grounding path for safety purposes, protection against electromagnetic interference and proper device operation.
- Equipment grounds should be bonded together and connected to the facility's main ground system for primary power.
- Keep all ground leads as short as possible.
- At all times, equipment ground terminal must be grounded during device operation and service.
- In addition to the safety precautions mentioned all electrical connections made must respect the applicable local jurisdiction electrical code.
- Before working on CTs, they must be short-circuited.
- To be certified for revenue metering, power providers and utility companies must verify that the billing energy meter performs to the stated accuracy. To confirm the meter's performance and calibration, power providers use field test standards to ensure that the unit's energy measurements are correct.



This product cannot be disposed of as unsorted municipal waste in the European Union. For proper recycling return this product to your supplier or a designated collection point. For more information go to www.recyclethis.info.

Safety words and definitions

The following symbols used in this document indicate the following conditions



Indicates a hazardous situation which, if not avoided, will result in death or serious injury.



Indicates a hazardous situation which, if not avoided, could result in death or serious injury.



Indicates a hazardous situation which, if not avoided, could result in minor or moderate injury.



Indicates practices not related to personal injury.



Indicates general information and practices, including operational information, that are not related to personal injury.

For further assistance

For product support, contact the information and call center as follows:

GE VERNOVA Grid Solutions

650 Markland Street

Markham, Ontario

Canada L6C 0M1

Worldwide telephone: +1 905 927 7070

Europe/Middle East/Africa telephone: +34 94 485 88 54

North America toll-free: 1 800 547 8629

Fax: +1 905 927 5098

Worldwide e-mail: multilin.tech@gevernova.com

Europe e-mail: multilin.tech.euro@gevernova.com

Website: <https://www.gevernova.com/grid-solutions/multilin>



Software and manuals for the EPM 9900P Meter can be found on the GE website at:

<https://www.gevernova.com/grid-solutions/automation/protection-control-metering/metering/epm-9900p>

Warranty

GE VERNOVA warrants most of its manufactured products for 10 years. For warranty details including any limitations and disclaimers, see our Terms and Conditions at <https://www.gevernova.com/grid-solutions/multilin/warranty.htm>

Table of contents

1: THREE-PHASE POWER MEASUREMENT	THREE PHASE SYSTEM CONFIGURATIONS	1-1
	WYE CONNECTION	1-1
	DELTA CONNECTION	1-3
	BLONDEL'S THEOREM AND THREE PHASE MEASUREMENT	1-4
	POWER, ENERGY AND DEMAND	1-6
	REACTIVE ENERGY AND POWER FACTOR	1-9
	HARMONIC DISTORTION	1-11
POWER QUALITY	1-13	

2: OVERVIEW AND SPECIFICATIONS	EPM 9900P METER OVERVIEW	2-1
	METER FEATURES	2-1
	DNP V3.00 LEVEL 2	2-3
	SOFTWARE OPTION TECHNOLOGY	2-4
	UPGRADING EPM 9900P SOFTWARE OPTION	2-4
	MEASUREMENTS AND CALCULATIONS	2-5
	DEMAND INTEGRATORS	2-7
	ORDERING	2-9
	ORDER CODES	2-9
	EPM ACCESSORIES	2-10
	SPECIFICATIONS	2-11
	ACCURACY	2-13
STANDARDS COMPLIANCE	2-15	

3: MECHANICAL INSTALLATION	MOUNTING THE EPM 9900P METER	3-1
	METER AND PANEL CUT-OUT DIMENSIONS	3-2
	MOUNTING INSTRUCTIONS	3-5
	REPLACING THE METER'S BATTERY	3-7

4: ELECTRICAL INSTALLATION	SAFETY CONSIDERATIONS WHEN INSTALLING METERS	4-1
	CT LEADS TERMINATED TO METER	4-2
	CT LEADS WITH NO METER TERMINATION (PASS THROUGH)	4-3
	QUICK CONNECT CRIMP-ON TERMINATIONS	4-4
	EPM 9900P MONITORED INPUTS	4-5
	VOLTAGE INPUTS	4-5
	WIRING THE MONITORED INPUTS - VAUX	4-6
	GROUND CONNECTIONS	4-6
	CURRENT INPUTS	4-6
	INSTRUMENT POWER SUPPLY CONNECTIONS	4-7
WIRING DIAGRAMS	4-11	

5: COMMUNICATION WIRING	COMMUNICATION OVERVIEW	5-1
	RJ45 AND FIBER ETHERNET CONNECTIONS	5-1
	ANSI OPTICAL PORT	5-2
	USB CONNECTION	5-2
	RS485 CONNECTIONS	5-3

	REMOTE COMMUNICATION WITH RS485	5-5
	PROGRAMMING MODEMS FOR REMOTE COMMUNICATION	5-5
	SELECTED MODEM STRINGS	5-6
	HIGH SPEED INPUTS CONNECTION	5-7
	IRIG-B CONNECTIONS	5-8
	TIME SYNCHRONIZATION ALTERNATIVES	5-9
<hr/>		
6: USING THE EPM 9900P METER'S TOUCH SCREEN DISPLAY	INTRODUCTION	6-1
	FIXED SYSTEM SCREENS	6-1
	DYNAMIC SCREENS	6-10
<hr/>		
7: TRANSFORMER LOSS COMPENSATION	INTRODUCTION	7-1
	EPM 9900P TRANSFORMER LOSS COMPENSATION	7-3
	LOSS COMPENSATION IN THREE ELEMENT INSTALLATIONS	7-4
<hr/>		
8: TIME-OF-USE FUNCTION	INTRODUCTION	8-1
	THE EPM 9900P METER'S TOU PROFILE	8-3
	TOU PRIOR SEASON AND MONTH	8-3
	UPDATING, RETRIEVING AND REPLACING TOU PROFILE	8-3
	DAYLIGHT SAVINGS AND DEMAND	8-3
<hr/>		
9: EPM 9900P NETWORK COMMUNICATIONS	HARDWARE OVERVIEW	9-1
	SPECIFICATIONS	9-2
	NETWORK CONNECTION	9-2
	TOTAL WEB SOLUTIONS	9-3
	VIEWING WEBPAGES	9-4
<hr/>		
10: EN 50160/IEC 61000-4-30 CLASS A REPORTING	OVERVIEW	10-1
	FLICKER MEASUREMENT	10-1
	THEORY OF OPERATION	10-2
	SUMMARY	10-3
	EN50160/IEC61000-4-30 SETTINGS	10-5
<hr/>		
11: USING THE I/O OPTIONS	OVERVIEW	11-1
	INSTALLING OPTION CARDS	11-2
	CONFIGURING OPTION CARDS	11-2
	PULSE OUTPUT/RS485 OPTION CARD (S OPTION)	11-3
	PULSE OUTPUT/RS485 OPTION CARD (S OPTION) WIRING	11-4
	ETHERNET OPTION CARD: RJ45 (E1) OR FIBER OPTIC (E2)	11-4
	RELAY OUTPUT OPTION CARD (R1)	11-6
	RELAY OUTPUT OPTION CARD (R1) WIRING	11-7
	DIGITAL INPUT OPTION CARD (D1)	11-7
	DIGITAL INPUT OPTION CARD (D1) WIRING	11-8
	OPTIONAL EXTERNAL I/O MODULES	11-9
	PORT OVERVIEW	11-10
	INSTALLING OPTIONAL EXTERNAL I/O MODULES	11-10
	POWER SOURCE FOR EXTERNAL I/O MODULES	11-11
	USING PSIO WITH MULTIPLE I/O MODULES	11-12

FACTORY SETTINGS AND RESET BUTTON	11-15
ANALOG TRANSDUCER SIGNAL OUTPUT MODULES	11-15
DIGITAL DRY CONTACT RELAY OUTPUT (FORM C) MODULE	11-16
DIGITAL SOLID STATE PULSE OUTPUT (KYZ) MODULE	11-17
ANALOG INPUT MODULES	11-19
ADDITIONAL EXTERNAL I/O MODULE SPECIFICATIONS	11-20

12: TEST MODE	INTRODUCTION	12-1
	LED PULSE OUTPUTS AND TEST MODE	12-2
	TEST MODE OPERATION	12-2
	ENTERING TEST MODE THROUGH GE COMMUNICATOR SOFTWARE	12-3
	ENTERING TEST MODE THROUGH THE DISPLAY	12-7
	ENTERING TEST MODE THROUGH A COMMUNICATION PORT	12-9
	POWER LOSS DURING TEST MODE	12-10
	TEST MODE TIMEOUT	12-10
	12.5: TEST MODE RESTRICTIONS	12-10

A: INSTALLING THE USB VIRTUAL COMM PORT	INTRODUCTION	A-1
	INSTALLING THE VIRTUAL PORT'S DRIVER	A-1
	CONNECTING TO THE VIRTUAL PORT	A-3

B: IEC 61850 ETHERNET NETWORK SERVER	OVERVIEW OF IEC 61850	B-1
	RELATIONSHIP OF CLIENTS AND SERVERS IN IEC 61850	B-2
	STRUCTURE OF IEC 61850 NETWORK	B-3
	STEPS TO CONFIGURING AN IEC 61850 NETWORK	B-6
	GE VERNOVA'S IEC 61850 IMPLEMENTATION	B-7
	REFERENCE MATERIALS	B-11
	FREE TOOLS FOR IEC 61850 START-UP	B-11
	COMMERCIAL TOOLS FOR IEC 61850 IMPLEMENTATION	B-12
	USING THE IEC 61850 ETHERNET NETWORK SERVER	B-12
	OVERVIEW	B-12
	CONFIGURING THE IEC 61850 PROTOCOL ETHERNET NETWORK SERVER	B-13
	TESTING	B-26

C: RESILIENT CYBER SECURITY™	INTRODUCTION	C-1
	PROGRAMMING RESILIENT CYBER SECURITY	C-2

D: USING SNMP	OVERVIEW	D-1
	BASICS OF SNMP	D-1
	SNMP IMPLEMENTATION	D-2
	MIBS	D-2
	PDUs	D-4
	TRAPS	D-4
	RFCS	D-4
	MODBUS MAP LOCATION OF SNMP SETTINGS	D-6
	SETTING UP SNMP	D-7
	CONFIGURE SNMP FOR THE METER	D-7
	SET UP SNMP NETWORK	D-8
	EXAMPLES	D-9

E: SYNCHROPHASOR SYSTEMS	OVERVIEW	E-1
	HISTORY OF SYNCHROPHASORS	E-1
	BASICS OF A SYNCHROPHASOR SYSTEM	E-2
	SYNCHROPHASOR SYSTEM REQUIREMENTS	E-3
	CAPABILITIES/BENEFITS OF A SYNCHROPHASOR SYSTEM	E-6
EPM 9900P METER'S SYNCHROPHASOR SUPPORT	E-9	

F: SETTING UP THE PMU	OVERVIEW	F-1
	DETAILS OF THE EPM 9900P METER'S SYNCHROPHASOR PMU IMPLEMENTATION	F-1
	PROGRAMMING THE METER'S SYNCHROPHASOR FEATURE	F-2
	STEP ONE - SELECT TIME SYNCHRONIZATION METHOD	F-2
	STEP TWO - ENABLE SYNCHROPHASORS	F-3
STEP THREE - PROGRAM THE METER'S NOMINAL FREQUENCY	F-4	
STEP FOUR - PROGRAM THE METER'S PMU SETTINGS	F-4	

G: MANUAL REVISION HISTORY	RELEASE NOTES	G-1
	MAJOR UPDATES	G-1

**GLOSSARY:
GLOSSARY**

Multilin™ EPM 9900P

Chapter 1: Three-Phase Power Measurement

This introduction to three-phase power and power measurement is intended to provide only a brief overview of the subject. The professional meter engineer or meter technician should refer to more advanced documents such as the EEI Handbook for Electricity Metering and the application standards for more in-depth and technical coverage of the subject.

1.1 Three Phase System Configurations

Three-phase power is most commonly used in situations where large amounts of power will be used because it is a more effective way to transmit the power and because it provides a smoother delivery of power to the end load. There are two commonly used connections for three-phase power, a wye connection or a delta connection. Each connection has several different manifestations in actual use.

When attempting to determine the type of connection in use, it is a good practice to follow the circuit back to the transformer that is serving the circuit. It is often not possible to conclusively determine the correct circuit connection simply by counting the wires in the service or checking voltages. Checking the transformer connection will provide conclusive evidence of the circuit connection and the relationships between the phase voltages and ground.

1.2 Wye Connection

The wye connection is so called because when you look at the phase relationships and the winding relationships between the phases it looks like a Y. Figure 1-1 depicts the winding relationships for a wye-connected service. In a wye service the neutral (or center point of the wye) is typically grounded. This leads to common voltages of 208/120 and 480/277 (where the first number represents the phase-to-phase voltage and the second number represents the phase-to-ground voltage).

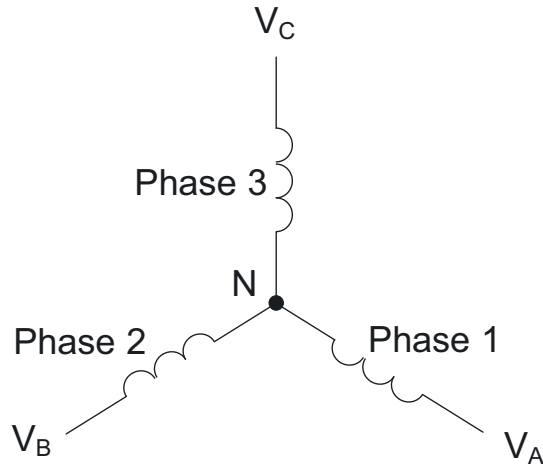

Figure 1-1: Three-phase Wye Winding

The three voltages are separated by 120° electrically. Under balanced load conditions the currents are also separated by 120°. However, unbalanced loads and other conditions can cause the currents to depart from the ideal 120° separation. Three-phase voltages and currents are usually represented with a phasor diagram. A phasor diagram for the typical connected voltages and currents is shown in Figure 1-2.

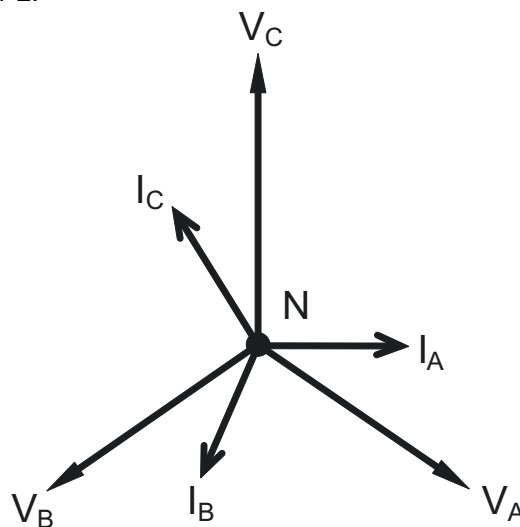

Figure 1-2: Phasor Diagram Showing Three-phase Voltages and Currents

The phasor diagram shows the 120° angular separation between the phase voltages. The phase-to-phase voltage in a balanced three-phase wye system is 1.732 times the phase-to-neutral voltage. The center point of the wye is tied together and is typically grounded. Table 1.1 shows the common voltages used in the United States for wye-connected systems.

Table 1.1: Common Phase Voltages on Wye Services

Phase to Ground Voltage	Phase to Phase Voltage
120 volts	208 volts
277 volts	480 volts
2,400 volts	4,160 volts
7,200 volts	12,470 volts

Table 1.1: Common Phase Voltages on Wye Services

Phase to Ground Voltage	Phase to Phase Voltage
7,620 volts	13,200 volts

Usually a wye-connected service will have four wires: three wires for the phases and one for the neutral. The three-phase wires connect to the three phases (as shown in Figure 1-1). The neutral wire is typically tied to the ground or center point of the wye.

In many industrial applications the facility will be fed with a four-wire wye service but only three wires will be run to individual loads. The load is then often referred to as a delta-connected load but the service to the facility is still a wye service; it contains four wires if you trace the circuit back to its source (usually a transformer). In this type of connection the phase to ground voltage will be the phase-to-ground voltage indicated in Table 1.1, even though a neutral or ground wire is not physically present at the load. The transformer is the best place to determine the circuit connection type because this is a location where the voltage reference to ground can be conclusively identified.

1.3 Delta Connection

Delta-connected services may be fed with either three wires or four wires. In a three-phase delta service the load windings are connected from phase-to-phase rather than from phase-to-ground. Figure 1-3 shows the physical load connections for a delta service.

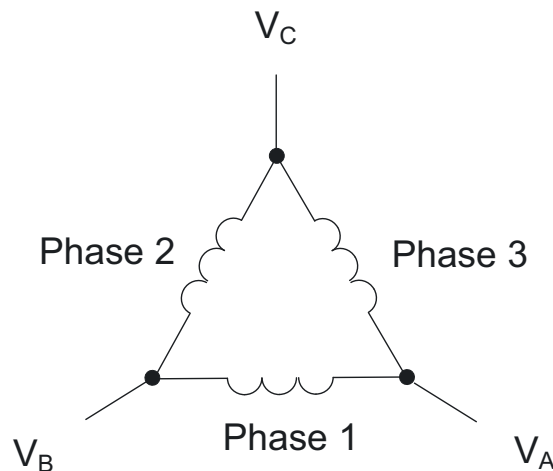
**Figure 1-3: Three-phase Delta Winding Relationship**

In this example of a delta service, three wires will transmit the power to the load. In a true delta service, the phase-to-ground voltage will usually not be balanced because the ground is not at the center of the delta.

Figure 1-4 shows the phasor relationships between voltage and current on a three-phase delta circuit.

In many delta services, one corner of the delta is grounded. This means the phase to ground voltage will be zero for one phase and will be full phase-to-phase voltage for the other two phases. This is done for protective purposes.

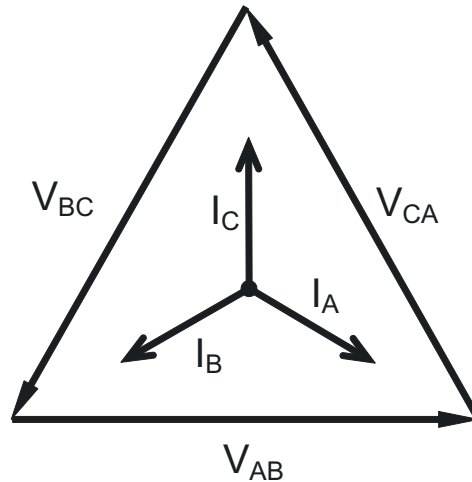

Figure 1-4: Phasor Diagram, Three-Phase Voltages and Currents, Delta-Connected

Another common delta connection is the four-wire, grounded delta used for lighting loads. In this connection the center point of one winding is grounded. On a 120/240 volt, four-wire, grounded delta service the phase-to-ground voltage would be 120 volts on two phases and 208 volts on the third phase. Figure 1-5 shows the phasor diagram for the voltages in a three-phase, four-wire delta system.

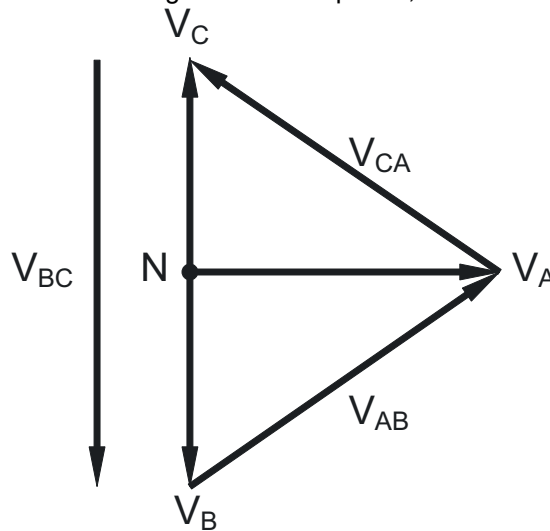

Figure 1-5: Phasor Diagram Showing Three-phase Four-Wire Delta-Connected System

1.4 Blondel’s Theorem and Three Phase Measurement

In 1893 an engineer and mathematician named Andre E. Blondel set forth the first scientific basis for polyphase metering. His theorem states:

If energy is supplied to any system of conductors through N wires, the total power in the system is given by the algebraic sum of the readings of N wattmeters so arranged that each of the N wires contains one current coil, the corresponding

potential coil being connected between that wire and some common point. If this common point is on one of the N wires, the measurement may be made by the use of N-1 Wattmeters.

The theorem may be stated more simply, in modern language:

In a system of N conductors, N-1 meter elements will measure the power or energy taken provided that all the potential coils have a common tie to the conductor in which there is no current coil.

Three-phase power measurement is accomplished by measuring the three individual phases and adding them together to obtain the total three phase value. In older analog meters, this measurement was accomplished using up to three separate elements. Each element combined the single-phase voltage and current to produce a torque on the meter disk. All three elements were arranged around the disk so that the disk was subjected to the combined torque of the three elements. As a result the disk would turn at a higher speed and register power supplied by each of the three wires.

According to Blondel's Theorem, it was possible to reduce the number of elements under certain conditions. For example, a three-phase, three-wire delta system could be correctly measured with two elements (two potential coils and two current coils) if the potential coils were connected between the three phases with one phase in common.

In a three-phase, four-wire wye system it is necessary to use three elements. Three voltage coils are connected between the three phases and the common neutral conductor. A current coil is required in each of the three phases.

In modern digital meters, Blondel's Theorem is still applied to obtain proper metering. The difference in modern meters is that the digital meter measures each phase voltage and current and calculates the single-phase power for each phase. The meter then sums the three phase powers to a single three-phase reading.

Some digital meters measure the individual phase power values one phase at a time. This means the meter samples the voltage and current on one phase and calculates a power value. Then it samples the second phase and calculates the power for the second phase. Finally, it samples the third phase and calculates that phase power. After sampling all three phases, the meter adds the three readings to create the equivalent three-phase power value. Using mathematical averaging techniques, this method can derive a quite accurate measurement of three-phase power.

More advanced meters actually sample all three phases of voltage and current simultaneously and calculate the individual phase and three-phase power values. The advantage of simultaneous sampling is the reduction of error introduced due to the difference in time when the samples were taken.

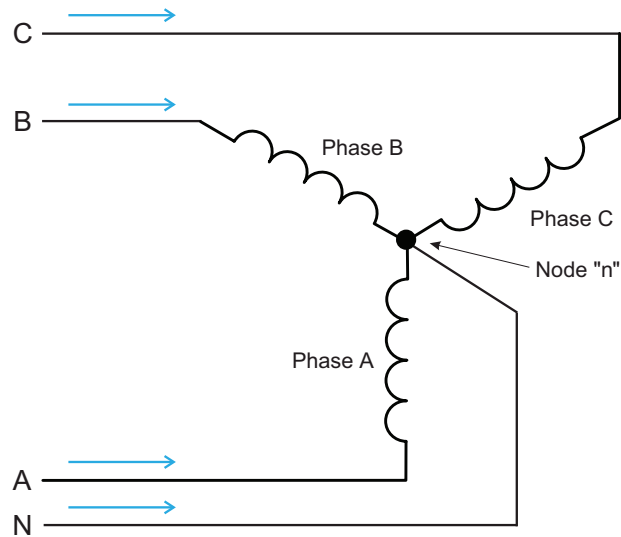

Figure 1-6: Three-Phase Wye Load Illustrating Kirchoff's Law and Blondel's Theorem

Blondel's Theorem is a derivation that results from Kirchoff's Law. Kirchoff's Law states that the sum of the currents into a node is zero. Another way of stating the same thing is that the current into a node (connection point) must equal the current out of the node. The law can be applied to measuring three-phase loads. Figure 1-6 shows a typical connection of a three-phase load applied to a three-phase, four-wire service. Kirchoff's Law holds that the sum of currents A, B, C and N must equal zero or that the sum of currents into Node "n" must equal zero.

If we measure the currents in wires A, B and C, we then know the current in wire N by Kirchoff's Law and it is not necessary to measure it. This fact leads us to the conclusion of Blondel's Theorem- that we only need to measure the power in three of the four wires if they are connected by a common node. In the circuit of Figure 1-6 we must measure the power flow in three wires. This will require three voltage coils and three current coils (a three-element meter). Similar figures and conclusions could be reached for other circuit configurations involving Delta-connected loads.

1.5 Power, Energy and Demand

It is quite common to exchange power, energy and demand without differentiating between the three. Because this practice can lead to confusion, the differences between these three measurements will be discussed.

Power is an instantaneous reading. The power reading provided by a meter is the present flow of watts. Power is measured immediately just like current. In many digital meters, the power value is actually measured and calculated over a one second interval because it takes some amount of time to calculate the RMS values of voltage and current. But this time interval is kept small to preserve the instantaneous nature of power.

Energy is always based on some time increment; it is the integration of power over a defined time increment. Energy is an important value because almost all electric bills are based, in part, on the amount of energy used.

Typically, electrical energy is measured in units of kilowatt-hours (kWh). A kilowatt-hour represents a constant load of one thousand watts (one kilowatt) for one hour. Stated another way, if the power delivered (instantaneous watts) is measured as 1,000 watts and the load was served for a one hour time interval then the load would have absorbed one kilowatt-hour of energy. A different load may have a constant power requirement of 4,000 watts. If the load were served for one hour it would absorb four kWh. If the load were served for 15 minutes it would absorb $\frac{1}{4}$ of that total or one kWh.

Figure 1-7 shows a graph of power and the resulting energy that would be transmitted as a result of the illustrated power values. For this illustration, it is assumed that the power level is held constant for each minute when a measurement is taken. Each bar in the graph will represent the power load for the one-minute increment of time. In real life the power value moves almost constantly.

The data from Figure 1-7 is reproduced in Table 1.2 to illustrate the calculation of energy. Since the time increment of the measurement is one minute and since we specified that the load is constant over that minute, we can convert the power reading to an equivalent consumed energy reading by multiplying the power reading times $1/60$ (converting the time base from minutes to hours).

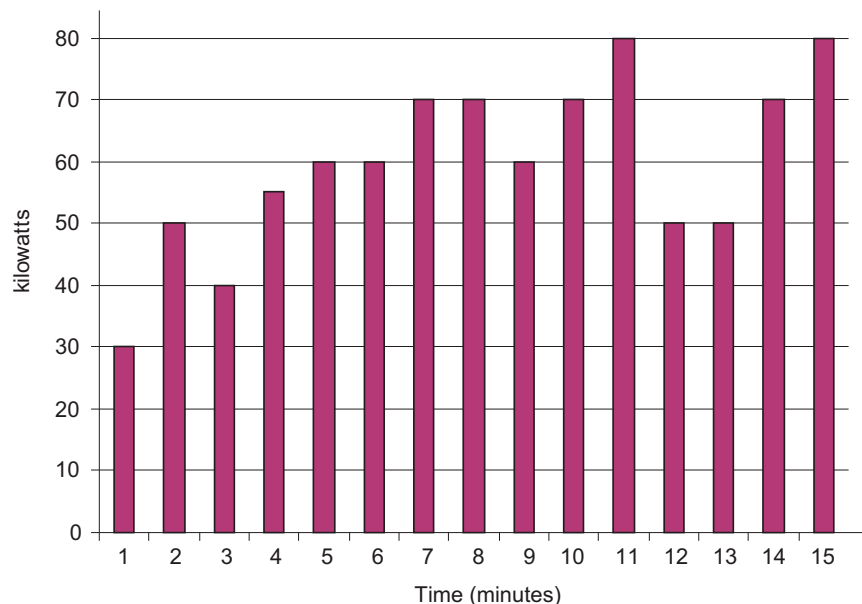

Figure 1-7: Power Use over Time

Table 1.2: Power and Energy Relationship over Time

Time Interval (minute)	Power (kW)	Energy (kWh)	Accumulated Energy (kWh)
1	30	0.50	0.50
2	50	0.83	1.33

Table 1.2: Power and Energy Relationship over Time

Time Interval (minute)	Power (kW)	Energy (kWh)	Accumulated Energy (kWh)
3	40	0.67	2.00
4	55	0.92	2.92
5	60	1.00	3.92
6	60	1.00	4.92
7	70	1.17	6.09
8	70	1.17	7.26
9	60	1.00	8.26
10	70	1.17	9.43
11	80	1.33	10.76
12	50	0.83	12.42
13	50	0.83	12.42
14	70	1.17	13.59
15	80	1.33	14.92

As in Table 1.2, the accumulated energy for the power load profile of Figure 1-7 is 14.92 kWh.

Demand is also a time-based value. The demand is the average rate of energy use over time. The actual label for demand is kilowatt-hours/hour but this is normally reduced to kilowatts. This makes it easy to confuse demand with power, but demand is not an instantaneous value. To calculate demand it is necessary to accumulate the energy readings (as illustrated in Figure 1-7) and adjust the energy reading to an hourly value that constitutes the demand.

In the example, the accumulated energy is 14.92 kWh. But this measurement was made over a 15-minute interval. To convert the reading to a demand value, it must be normalized to a 60-minute interval. If the pattern were repeated for an additional three 15-minute intervals the total energy would be four times the measured value or 59.68 kWh. The same process is applied to calculate the 15-minute demand value. The demand value associated with the example load is 59.68 kWh/hr or 59.68 kWd. Note that the peak instantaneous value of power is 80 kW, significantly more than the demand value.

Figure 1-8 shows another example of energy and demand. In this case, each bar represents the energy consumed in a 15-minute interval. The energy use in each interval typically falls between 50 and 70 kWh. However, during two intervals the energy rises sharply and peaks at 100 kWh in interval number 7. This peak of usage will result in setting a high demand reading. For each interval shown the demand value would be four times the indicated energy reading. So interval 1 would have an associated demand of 240 kWh/hr. Interval 7 will have a demand value of 400 kWh/hr. In the data shown, this is the peak demand value and would be the number that would set the demand charge on the utility bill.

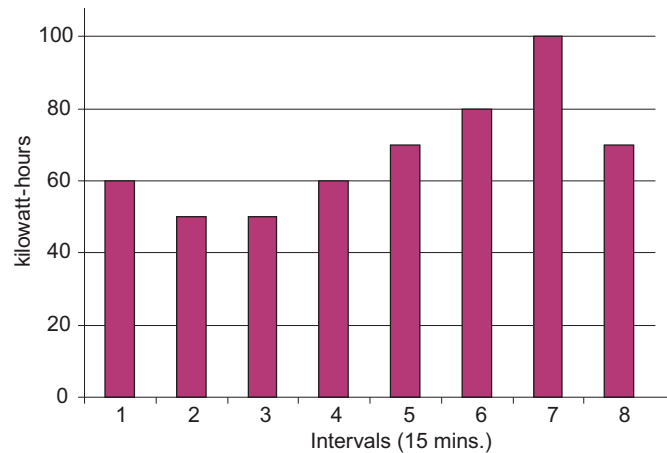

Figure 1-8: Energy Use and Demand

As can be seen from this example, it is important to recognize the relationships between power, energy and demand in order to control loads effectively or to monitor use correctly.

1.6 Reactive Energy and Power Factor

The real power and energy measurements discussed in the previous section relate to the quantities that are most used in electrical systems. But it is often not sufficient to only measure real power and energy. Reactive power is a critical component of the total power picture because almost all real-life applications have an impact on reactive power. Reactive power and power factor concepts relate to both load and generation applications. However, this discussion will be limited to analysis of reactive power and power factor as they relate to loads. To simplify the discussion, generation will not be considered.

Real power (and energy) is the component of power that is the combination of the voltage and the value of corresponding current that is directly in phase with the voltage. However, in actual practice the total current is almost never in phase with the voltage. Since the current is not in phase with the voltage, it is necessary to consider both the in-phase component and the component that is at quadrature (angularly rotated 90° or perpendicular) to the voltage. Figure 1-9 shows a single-phase voltage and current and breaks the current into its in-phase and quadrature components.

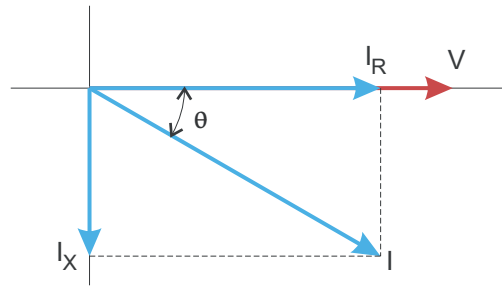

Figure 1-9: Voltage and Complex Current

The voltage (V) and the total current (I) can be combined to calculate the apparent power or VA. The voltage and the in-phase current (IR) are combined to produce the real power or watts. The voltage and the quadrature current (IX) are combined to calculate the reactive power.

The quadrature current may be lagging the voltage (as shown in Figure 1-9) or it may lead the voltage. When the quadrature current lags the voltage the load is requiring both real power (watts) and reactive power (VARs). When the quadrature current leads the voltage the load is requiring real power (watts) but is delivering reactive power (VARs) back into the system; that is VARs are flowing in the opposite direction of the real power flow.

Reactive power (VARs) is required in all power systems. Any equipment that uses magnetization to operate requires VARs. Usually the magnitude of VARs is relatively low compared to the real power quantities. Utilities have an interest in maintaining VAR requirements at the customer to a low value in order to maximize the return on plant invested to deliver energy. When lines are carrying VARs, they cannot carry as many watts. So keeping the VAR content low allows a line to carry its full capacity of watts. In order to encourage customers to keep VAR requirements low, some utilities impose a penalty if the VAR content of the load rises above a specified value.

A common method of measuring reactive power requirements is power factor. Power factor can be defined in two different ways. The more common method of calculating power factor is the ratio of the real power to the apparent power. This relationship is expressed in the following formula:

$$\text{Total PF} = \text{real power} / \text{apparent power} = \text{watts/VA}$$

This formula calculates a power factor quantity known as Total Power Factor. It is called Total PF because it is based on the ratios of the power delivered. The delivered power quantities will include the impacts of any existing harmonic content. If the voltage or current includes high levels of harmonic distortion the power values will be affected. By calculating power factor from the power values, the power factor will include the impact of harmonic distortion. In many cases this is the preferred method of calculation because the entire impact of the actual voltage and current are included.

A second type of power factor is Displacement Power Factor. Displacement PF is based on the angular relationship between the voltage and current. Displacement power factor does not consider the magnitudes of voltage, current or power. It is solely based on the phase angle differences. As a result, it does not include the impact of harmonic distortion. Displacement power factor is calculated using the following equation:

$$\text{Displacement PF} = \cos\theta$$

where θ is the angle between the voltage and the current (see Fig. 1-9).

In applications where the voltage and current are not distorted, the Total Power Factor will equal the Displacement Power Factor. But if harmonic distortion is present, the two power factors will not be equal.

1.7 Harmonic Distortion

Harmonic distortion is primarily the result of high concentrations of non-linear loads. Devices such as computer power supplies, variable speed drives and fluorescent light ballasts make current demands that do not match the sinusoidal waveform of AC electricity. As a result, the current waveform feeding these loads is periodic but not sinusoidal. Figure 1-10 shows a normal, sinusoidal current waveform. This example has no distortion.

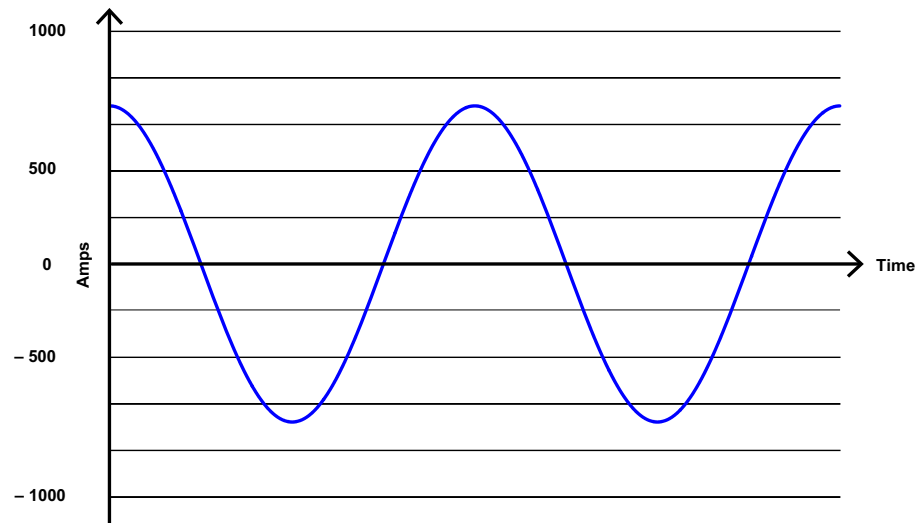

Figure 1-10: Nondistorted Current Waveform

Figure 1-11 shows a current waveform with a slight amount of harmonic distortion. The waveform is still periodic and is fluctuating at the normal 60 Hz frequency. However, the waveform is not a smooth sinusoidal form as seen in Figure 1-10.

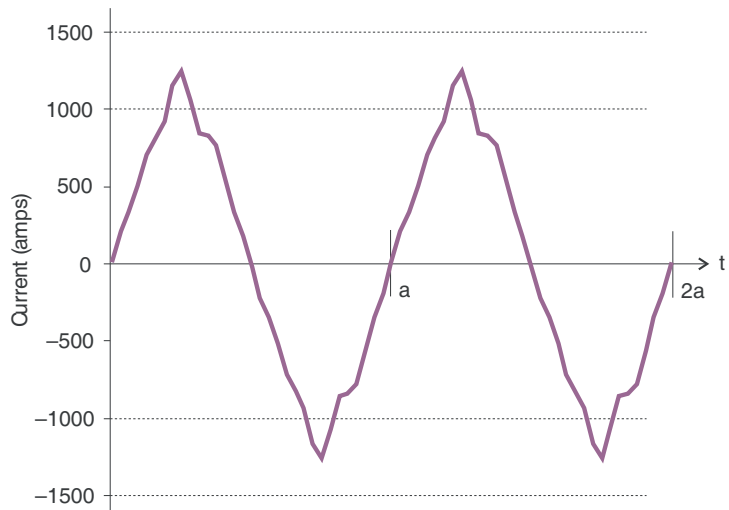

Figure 1-11: Distorted Current Waveform

The distortion observed in Figure 1-11 can be modeled as the sum of several sinusoidal waveforms of frequencies that are multiples of the fundamental 60 Hz frequency. This modeling is performed by mathematically disassembling the distorted waveform into a collection of higher frequency waveforms.

These higher frequency waveforms are referred to as harmonics. Figure 1-12 shows the content of the harmonic frequencies that make up the distortion portion of the waveform in Figure 1-11.

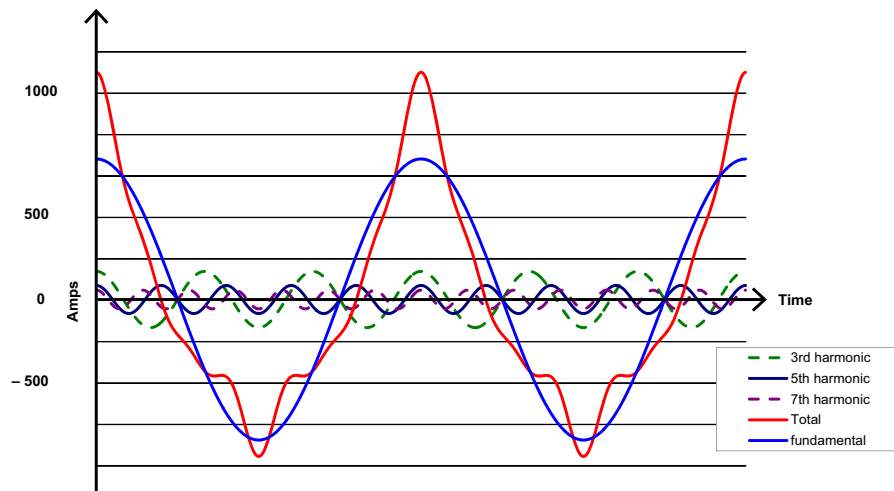

Figure 1-12: Waveforms of the Harmonics

The waveforms shown in Figure 1-12 are not smoothed but do provide an indication of the impact of combining multiple harmonic frequencies together.

When harmonics are present it is important to remember that these quantities are operating at higher frequencies. Therefore, they do not always respond in the same manner as 60 Hz values.

Inductive and capacitive impedance are present in all power systems. We are accustomed to thinking about these impedances as they perform at 60 Hz. However, these impedances are subject to frequency variation.

$$X_L = j\omega L \quad \text{and}$$

$$X_C = 1/j\omega C$$

At 60 Hz, $\omega = 377$; but at 300 Hz (5th harmonic) $\omega = 1,885$. As frequency changes impedance changes and system impedance characteristics that are normal at 60 Hz may behave entirely differently in the presence of higher order harmonic waveforms.

Traditionally, the most common harmonics have been the low order, odd frequencies, such as the 3rd, 5th, 7th, and 9th. However newer, non-linear loads are introducing significant quantities of higher order harmonics.

Since much voltage monitoring and almost all current monitoring is performed using instrument transformers, the higher order harmonics are often not visible. Instrument transformers are designed to pass 60 Hz quantities with high accuracy. These devices, when designed for accuracy at low frequency, do not pass high frequencies with high accuracy; at frequencies above about 1200 Hz they pass almost no information. So when instrument transformers are used, they effectively filter out higher frequency harmonic distortion making it impossible to see.

However, when monitors can be connected directly to the measured circuit (such as direct connection to a 480 volt bus) the user may often see higher order harmonic distortion. An important rule in any harmonics study is to evaluate the type of equipment and connections before drawing a conclusion. Not being able to see harmonic distortion is not the same as not having harmonic distortion.

It is common in advanced meters to perform a function commonly referred to as waveform capture. Waveform capture is the ability of a meter to capture a present picture of the voltage or current waveform for viewing and harmonic analysis. Typically a waveform capture will be one or two cycles in duration and can be viewed as the actual waveform, as a spectral view of the harmonic content, or a tabular view showing the magnitude and phase shift of each harmonic value. Data collected with waveform capture is typically not saved to memory. Waveform capture is a real-time data collection event.

Waveform capture should not be confused with waveform recording that is used to record multiple cycles of all voltage and current waveforms in response to a transient condition.

1.8 Power Quality

Power quality can mean several different things. The terms “power quality” and “power quality problem” have been applied to all types of conditions. A simple definition of “power quality problem” is any voltage, current or frequency deviation that results in mis-operation or failure of customer equipment or systems. The causes of power quality problems vary widely and may originate in the customer equipment, in an adjacent customer facility or with the utility.

In his book *Power Quality Primer*, Barry Kennedy provided information on different types of power quality problems. Some of that information is summarized in Table 1.3.

Table 1.3: Typical Power Quality Problems and Sources

Cause	Disturbance Type	Source
Impulse transient	Transient voltage disturbance, sub-cycle duration	Lightning Electrostatic discharge Load switching Capacitor switching
Oscillatory transient with decay	Transient voltage, sub-cycle duration	Line/cable switching Capacitor switching Load switching
Sag/swell	RMS voltage, multiple cycle duration	Remote system faults
Interruptions	RMS voltage, multiple seconds or longer duration	System protection Circuit breakers Fuses Maintenance
Under voltage/over voltage	RMS voltage, steady state, multiple seconds or longer duration	Motor starting Load variations Load dropping
Voltage flicker	RMS voltage, steady state, repetitive condition	Intermittent loads Motor starting Arc furnaces
Harmonic distortion	Steady state current or voltage, long-term duration	Non-linear loads System resonance

It is often assumed that power quality problems originate with the utility. While it is true that power quality problems can originate with the utility system, many problems originate with customer equipment. Customer-caused problems may manifest themselves inside the customer location or they may be transported by the utility system to another adjacent customer. Often, equipment that is sensitive to power quality problems may in fact also be the cause of the problem.

If a power quality problem is suspected, it is generally wise to consult a power quality professional for assistance in defining the cause and possible solutions to the problem.

Multilin™ EPM 9900P

Chapter 2: Overview and Specifications

2.1 EPM 9900P Meter Overview

The Multilin™ EPM 9900P is one of the most advanced monitoring products on the market today, providing a comprehensive perspective of energy usage and power quality metrics for critical energy circuits. The EPM 9900P is ideal for industrial and utility substation automation applications where both power quality monitoring, high accuracy and easy integration/commissioning are required.

2.1.1 Meter Features

- Class A IEC 61000-4-30 Ed. 3 power quality measurement records elements of electrical power, including power quality and transients, and supports reports on the quality of the electrical circuit in compliance with the IEC 61000-4-30 Class A and EN 50160 international standards
- 50 MHz transient recording provides high resolution for event and waveform capture
- Auto-calibrating architecture ensures the meter maintains its high accuracy by self-calibrating every ten seconds, assuring you of precision measurements for your critical metering applications
- Phasor Measurement Unit (PMU) functionality, supporting both P and M classes, for grid Synchrophasor monitoring
- Resilient Cyber Security™ features to protect metering data including role-based security and safeguards for firmware integrity

Revenue Metering

- Highly accurate 0.06% watt-hour accuracy (at Unity PF) in a field-mounted device
- Constant Calibration™ architecture, in which the meter auto-calibrates itself every ten seconds, means the meter stays accurate over time and temperature changes

- Meets ANSI C12.20 (0.2 Class) Standard and IEC 62053-22 (0.2S Class) Standard accuracy specifications
- Adjusts for transformer and line losses, using user-defined compensation factors
- Adjusts for CT and PT errors
- Counts pulses and aggregates different loads
- Offers a Test Mode that lets the user verify the accuracy of readings without affecting billing data, and preset energy accumulators for adjustments upon exiting Test Mode (see: Test Mode for detailed information)
- Offers a perpetual calendar and multiple tiered rates for TOU calculation (see: Time-of-Use Function for detailed information)

Power Quality

- Measures up to 800,000 samples per cycle on a transient voltage event (50 MHz)
- Records power quality and reliability captures on voltage or current waveform signals
- Offers inputs for neutral-to-ground voltage measurements
- Accurate time sync of power quality events/waveforms with support for IRIG-B and IEC 1588 Precision Time Protocol (PTPv2) for PMU functionality
- Measures Harmonics per IEC 61000-4-30 and Flicker per IEC 61000-4-15 Class A standards; Flicker analysis is available for Instantaneous, Short-Term, and Long-Term forms (see Chapter 10 for detailed information)
- Provides programmable EN 50160 report generation to meet different jurisdictional requirements

RTU Features

- Advanced monitoring capabilities that provide detailed and precise pictures of any metered point within a distribution network
- Extensive I/O capability that is available in conjunction with all metering functions. I/O includes:
 - Optional Relay Output card with 6 relay contact outputs (up to 2 Relay Output cards can be installed in the meter)
 - Optional Digital Input card with 16 status inputs (up to 2 Digital Input cards can be installed in the meter)
 - Optional External I/O modules consisting of up to 4 Analog Output modules, 1 Digital Dry Contact Relay Output module, up to 4 Digital Solid State Pulse Output modules, and up to 4 Analog Input Modules



NOTE

See *Chapter 11* for detailed information on the I/O options.

- Logging of Modbus slave devices for RTU concentrator functions

Extensive Memory and Communication

- On board mass memory (up to 4000 Megabytes compact Flash) that enables the EPM 9900P meter to retrieve and store multiple logs for many years; the amount of memory used by the logs is assignable by the user
- Software Option technology that allows you to upgrade the meter and memory in the field, without removing it from installation

- Standard 10/100BaseT RJ45 Ethernet that allows you to connect to a PC via Modbus TCP/IP; a second, optional Ethernet connection that can be either RJ45 or Fiber Optic; each Ethernet card offers up to 32 Modbus TCP/IP connections, and, with Software Options B, C, E or F, either port offers an IEC 61850 Protocol server
- Ethernet ports that are separately programmable for server and protocol port control
- A USB Virtual Com Port, compatible with USB1.1/USB2.0, that provides serial communication
- Optional RS485/Pulse Output card that provides two RS485 ports and 4 pulse outputs that are user programmable to reflect VAR-hours, Watt-hours, or VA-hours
- Support for multiple communication protocols including Modbus, DNP V3.00 (see *DNP V3.00 Level 2* for more details), IEC 61850 (see *IEC 61850 Ethernet Network Server*), SNMP (see *Using SNMP*)
- 1 cycle high-speed updates and programmable updates from 2 - 20 cycles RMS, that are available for Control applications
- Multiple time synchronization options including IRIG-B, IEEE 1588 Precision Time Protocol (PTPv2)
- Synchrophasor PMU support

2.2 DNP V3.00 Level 2

The EPM 9900P meter supports DNP V3.00 Level 2 over both serial and dual Ethernet ports.

DNP Level 2 Features

- Up to 136 measurements (64 Binary Inputs, 8 Binary Counters, 64 Analog Inputs) can be mapped to DNP Static Points (over 3000) in the customizable DNP Point Map.
- Report-by-Exception Processing (DNP Events) - Deadbands can be set on a per-point basis.
- Freeze Commands - Available commands are Freeze, Freeze/No-Ack, Freeze with Time, and Freeze with Time/No-Ack.
- Freeze with Time Commands enable the EPM 9900P meter to have internal time-driven Frozen and Frozen Event data. When the EPM 9900P meter receives the time and interval, the data is created.

More information is available in the *EPM 9000 Series DNP Guide*.



NOTE

Visit the GE VERNOVA website : <https://www.gevernova.com/grid-solutions/automation/protection-control-metering/metering/epm-9900p>

for more details.

2.3 Software Option Technology

The EPM 9900P meter is equipped with Software Option technology, a virtual firmware-based switch that allows you to enable meter features through software communication. Software Option technology allows the unit to be upgraded after installation without removing it from service.

EPM 9900P Available Software Options

- Software Option (A) - 512MB memory with 512 samples/cycle
- Software Option (B) - 1GB memory with 1024 samples/cycle, IEC 61850 Communications Protocol
- Software Option (C) - 4GB memory with 1024 samples/cycle, IEC 61850 Communications Protocol and 50MHz Transient Recording
- Software Option (D) - 512MB memory with 512 samples/cycle, Synchrophasor PMU
- Software Option (E) - 1GB memory with 1024 samples/cycle, IEC 61850 Communications Protocol, Synchrophasor PMU
- Software Option (F) - 4GB memory with 1024 samples/cycle, IEC 61850 Communications Protocol, 50MHz Transient Recording, Synchrophasor PMU



Software Options B, C, E, and F enable IEC 61850 Protocol Server for the Main Ethernet card. See: IEC 61850 Ethernet Network Server for details.

2.3.1 Upgrading EPM 9900P Software Option

Upgrades can be purchased separately from the meter for example to upgrade functionality after purchase of the meter unit. Table 2.3: Upgrade Software lists the order codes to upgrade software options.

Please follow the following steps to upgrade to a higher Software Option:

1. Contact the GE Grid Solutions sales team to place your order. You will be asked for the following information:
 - Desired Software Option upgrade.
 - Serial number(s) of the meter you are upgrading.
 - Purchase Order - Customer Information, etc.
2. Upon order completion a Software Option upgrade key is provided for the specific meter unit. Use the following steps to enter the key:
 - Power up your EPM 9900P meter.
 - Open GE Communicator software and connect to the meter via GE Communicator. (See the *GE Communicator Instruction Manual* for detailed instructions: you can open the manual online by clicking **Help > Contents** from the GE Communicator Main screen).
 - Click **Tools > Change Software Option** from the Title Bar of the Main screen. A screen opens, requesting the upgrade key.

- Enter the provided upgrade key and click OK. The Software Option upgrade key is enabled and the meter is reset.
- Upon startup the upgraded functionality is enabled in the meter.

2.4 Measurements and Calculations

The EPM 9900P meter measures many different power parameters. Following is a list of the formulas used to perform calculations with samples for Wye and Delta services.

Samples for Wye/Delta: $v_a, v_b, v_c, i_a, i_b, i_c, i_n$

Root Mean Square (RMS) of Phase Voltages: N = number of samples

For Wye: $x = a, b, c$

$$V_{RMS_x} = \sqrt{\frac{\sum_{t=1}^N (V_{x(t)} V_{n(t)})^2}{N}} \quad (\text{EQ 2.1})$$

Root Mean Square (RMS) of Line Currents: N = number of samples

For Wye: $x = a, b, c, n$

For Delta: $x = a, b, c$

$$I_{RMS_x} = \sqrt{\frac{\sum_{t=1}^N i_{x(t)}^2}{N}} \quad (\text{EQ 2.2})$$

Root Mean Square (RMS) of Line Voltages: N = number of samples

For Wye: $x, y = a,b$ or b,c or c,a

$$V_{RMS_{xy}} = \sqrt{\frac{\sum_{t=1}^N (V_{x(t)} - V_{y(t)})^2}{N}} \quad (\text{EQ 2.3})$$

For Delta: $x, y = a,b$ or b,c or c,a

$$I_{S_{xy}} = \sqrt{\frac{\sum_{t=1}^N (V_{x(t)} - V_{y(t)})^2}{N}} \quad (\text{EQ 2.4})$$

Power (Watts) per phase: N = number of samples

For Wye: $x = an, bn, cn$

$$W_x = \frac{\sum_{t=1}^N V_{x(t)} \cdot i_{x(t)}}{N} \quad (\text{EQ 2.5})$$

Apparent Power (VA) per phase:

For Wye: x = an, bn, cn

$$VA_x = V_{RMS_x} \cdot I_{RMS_x} \tag{EQ 2.6}$$

Reactive Power (VAR) per phase:

For Wye: x = a, b, c

$$VAR_x = \sqrt{VA_x^2 - Watt_x^2} \tag{EQ 2.7}$$

Active Power (Watts) Total: N = number of samples

For Wye:

$$W_T = W_a + W_b + W_c \tag{EQ 2.8}$$

For Delta:

$$W_T = \frac{\sum_{t=1}^N (V_{ab(t)} \cdot i_{a(t)} - V_{bc(t)} \cdot i_{c(t)})}{N} \tag{EQ 2.9}$$

Reactive Power (VAR) Total: N = number of samples

For Wye:

$$VAR_T = \sqrt{VA_T^2 - W_T^2} \tag{EQ 2.10}$$

For Delta:

$$\tag{EQ 2.11}$$

$$VAR_T = \sqrt{(V_{RMS_{ab}} \cdot I_{RMS_a})^2 - \left[\frac{\sum_{t=1}^N V_{ab(t)} \cdot i_{a(t)}}{N} \right]^2} + \sqrt{(V_{RMS_{bc}} \cdot I_{RMS_c})^2 - \left[\frac{\sum_{t=1}^N V_{bc(t)} \cdot i_{c(t)}}{N} \right]^2}$$

Apparent Power (VA) Total:

For Wye:

$$VA_T = VA_a + VA_b + VA_c \tag{EQ 2.12}$$

For Delta:

$$VA_T = \sqrt{W_T^2 + VAR_T^2} \tag{EQ 2.13}$$

Power Factor (PF):

For Wye: x = a,b,c,T

For Delta: $x = T$

$$PF_x = \frac{Watt_x}{VA_x} \quad (\text{EQ 2.14})$$

Phase Angles:

$$\angle = \cos^{-1}(PF) \quad (\text{EQ 2.15})$$

% Total Harmonic Distortion (%THD):

For Wye: $x = v_{an}, v_{bn}, v_{cn}$

For Delta: $x = i_a, i_b, i_c, v_{ab}, v_{bc}, v_{ca}$

$$THD = \frac{\sqrt{\sum_{h=2}^{127} (RMS_{xh})^2}}{RMS_{x1}} \quad (\text{EQ 2.16})$$

K Factor:

$x = i_a, i_b, i_c$

$$KFactor = \frac{\sum_{h=1}^{127} (h \cdot RMS_{xh})^2}{\sum_{h=1}^{127} (RMS_{xh})^2} \quad (\text{EQ 2.17})$$

Watt hour (Wh): N = number of samples

$$Wh = \sum_{t=1}^N \frac{W_{(t)}}{3600_{s/hr}} \quad (\text{EQ 2.18})$$

VAR hour (VARh): N = number of samples

$$VARh = \sum_{t=1}^N \frac{VAR_{(t)}}{3600_{s/hr}} \quad (\text{EQ 2.19})$$

2.5 Demand Integrators

Power utilities take into account both energy consumption and peak demand when billing customers. Peak demand, expressed in kilowatts (kW), is the highest level of demand recorded during a set period of time, called the interval. The EPM 9900P meter supports the following most popular conventions for averaging demand and peak demand: Block Window Demand, Rolling Window Demand, and Thermal Demand. You can program and access all conventions concurrently with the GE Communicator software (see the *GE Communicator Instruction Manual*). Note that you can also set TOU demand intervals for the EPM 9900P meter.

Block (Fixed) Window Demand:

This convention records the average (arithmetic mean) demand for consecutive time intervals (usually 15 minutes).

Example: A typical setting of 15 minutes produces an average value every 15 minutes (at 12:00, 12:15, 12:30, etc.) for power reading over the previous fifteen minute interval (11:45-12:00, 12:00-12:15, 12:15-12:30, etc.).

Rolling (Sliding) Window Demand:

Rolling Window Demand functions like multiple overlapping Block Window Demands. The programmable settings provided are the number and length of demand subintervals. At every subinterval, an average (arithmetic mean) of power readings over the subinterval is internally calculated. This new subinterval average is then averaged (arithmetic mean), with as many previous subinterval averages as programmed, to produce the Rolling Window Demand.

Example: With settings of 3 five-minute subintervals, subinterval averages are computed every 5 minutes (12:00, 12:05, 12:10, etc.) for power readings over the previous five-minute interval (11:55-12:00, 12:00-12:05, 12:05-12:10, 12:10-12:15, etc.). Further, every 5 minutes, the subinterval averages are averaged in groups of 3 (12:00, 12:05, 12:10, 12:15, etc.) to produce a fifteen (5x3) minute average every 5 minutes (rolling (sliding) every 5 minutes) (11:55-12:10, 12:00-12:15, etc.).

Thermal Demand:

Traditional analog Watt-hour (Wh) meters use heat-sensitive elements to measure temperature rises produced by an increase in current flowing through the meter. A pointer moves in proportion to the temperature change, providing a record of demand. The pointer remains at peak level until a subsequent increase in demand moves it again, or until it is manually reset. The EPM 9900P meter mimics traditional meters to provide Thermal Demand readings.

Each second, as a new power level is computed, a recurrence relation formula is applied. This formula recomputes the thermal demand by averaging a small portion of the new power value with a large portion of the previous thermal demand value. The proportioning of new to previous is programmable, set by an averaging interval. The averaging interval represents a 90% change in thermal demand to a step change in power.

2.6 Ordering

2.6.1 Order Codes

Table 2.1: EPM 9900P Order Codes

PL9900P	-	*	-	*	-	*	-	*	-	*	-	*	-	*	-	*	Description
Base Unit	PL9900	P															EPM 9900P Multi-function metering system
Enclosure	ENC120																NEMA 1 rated, indoor, single meter enclosure, 120V
	ENC277																NEMA 1 rated, indoor, single meter enclosure, 277V
	XXXXX X																No enclosure
Control Power	AC																100 to 240 VAC
	HI																90 to 265 VAC or 100 to 240 VDC
	LD																18 to 60 VDC (24 to 48 VDC Systems)
Frequency	5																50 Hz AC frequency system
	6																60 Hz AC frequency system
Current Inputs	1																1 Amp
	5																5 Amps
Software	A																512 MB with 512 samples/cycle
	B																1 GB memory with 1024 samples/cycle, IEC 61850 Communications Protocol
	C																4 GB memory with 1024 samples/cycle, IEC 61850 Communications Protocol and 50MHz Transient Recording
	D																512 MB memory with 512 samples/cycle, Synchrophasor PMU
	E																1 GB memory with 1024 samples/cycle, IEC 61850 Communications Protocol, Synchrophasor PMU
	F																4 GB memory with 1024 samples/cycle, IEC 61850 Communications Protocol, 50MHz Transient Recording, Synchrophasor PMU
I/O Modules (Slot 1)	S																2-ports RS485 and 4 Pulse outputs
	X																Empty slot
(Slot 2)	E1																Second Ethernet Port, 10/100BaseTX, RJ45
	E2																Second Ethernet Port, 100FX, Multimode, ST connector
	XX																Empty slot
(Slot 3)	R1																6 Relay outputs
	D1																16 Status inputs
	XX																Empty slot
(Slot 4)	R1																6 Relay outputs
	D1																16 Status inputs
	XX																Empty slot

2.6.2 EPM Accessories

This section describes accessories for the EPM 9900P which are available separately for the meter.

External Input/Output (I/O) Modules

The following external (I/O) modules are available:



External modules and accessories must be ordered separately from base meters.

Analog output modules:

PL9000	-	*	-	*	-	*	-	*	-	*	-	0	-	0
	1	M	A	O	N	4	0							Four channel 0 to 1 mA analog outputs
	1	M	A	O	N	8	0							Eight channel 0 to 1 mA analog outputs
	2	O	M	A	O	N	4							Four channel 4 to 20 mA analog outputs
	2	O	M	A	O	N	8							Eight channel 4 to 20 mA analog outputs

Analog input modules:

PL9000	-	*	-	*	-	*	-	*	-	*	-	0	-	0
	8	A	I	1	0	0	0	0	0	0				Eight channel 0 to 1 mA analog inputs
	8	A	I	2	0	0	0	0	0	0				Eight channel 4 to 20 mA analog inputs
	8	A	I	3	0	0	0	0	0	0				Eight channel 0 to 5 V DC analog inputs
	8	A	I	4	0	0	0	0	0	0				Eight channel 0 to 10 V DC analog inputs

Digital dry contact relay/solid state pulse outputs:

PL9000	-	*	-	*	-	*	-	0	-	0	-	0	-	0
	4	R	0	1	0	0	0	0	0	0				Four relay outputs, 5A, 250VAC/30 VDC, form C latching
	4	P	0	1	0	0	0	0	0	0				Four solid state pulse outputs, form A or C KYZ pulses, 20 pulses/sec. max.

Auxiliary output power supply and mounting:

PL9000	-	*	-	*	-	I	-	O	-	0	-	0	-	0
	M	B	I	O	0	0	0	0	0	0				Mounting bracket (required for external modules)
	P	S	I	O	0	0	0	0	0	0				Auxiliary power supply (required for external modules)

Expandable Input/Output (I/O) Cards

The following table describes the expandable communications cards available for the EPM 9900P for specific slots.

Table 2.2: Expandable I/O Cards

Part Number	Description	I/O Module
PL9900P-ACC-SXX	2-ports RS485 and 4 Pulse Outputs	Slot 1
PL9900P-ACC-E1X	Second Ethernet Port, 10/100BaseTX, RJ45	Slot 2
PL9900P-ACC-E2X	Second Ethernet Port, 100FX, Multimode, ST connector	Slot 2
PL9900P-ACC-R1X	6 Relay Outputs	Slot 3
PL9900P-ACC-D1X	16 Status Inputs	Slot 3
PL9900P-ACC-R1X (same as Slot 3)	6 Relay Outputs	Slot 4

PL9900P-ACC-D1X (same as Slot 3)	16 Status Inputs	Slot 4
----------------------------------	------------------	--------

Upgrade Software Options

The following table describes the options available for upgrading software for the EPM 9900P.

Table 2.3: Upgrade Software

Part Number	Description
PL9900P-ACC-SAD	Upgrade Software option A to D: 512 MB memory with 512 samples/cycle, Synchrophasor PMU
PL9900P-ACC-SBE	Upgrade Software option B to E: 1 GB memory with 1024 samples/cycle, IEC 61850 Communications Protocol, Synchrophasor PMU
PL9900P-ACC-SCF	Upgrade Software option C to F: 4 GB memory with 1024 samples/cycle, IEC 61850 Communications Protocol, 50MHz Transient Recording, Synchrophasor PMU
PL9900P-ACC-SDE	Upgrade Software option D to E: 1 GB memory with 1024 samples/cycle, IEC 61850 Communications Protocol, Synchrophasor PMU
PL9900P-ACC-SDF	Upgrade Software option D to F: 4 GB memory with 1024 samples/cycle, IEC 61850 Communications Protocol, 50MHz Transient Recording, Synchrophasor PMU
PL9900P-ACC-SEF	Upgrade Software option E to F: 4 GB memory with 1024 samples/cycle, IEC 61850 Communications Protocol, 50MHz Transient Recording, Synchrophasor PMU

2.7 Specifications

POWER SUPPLY

Range: **AC:** UL Rated to 100-240 VAC
HI: Universal, UL rated to 90-265 VAC or 100-240 VDC
LD: UL rated to 18-60 VDC (24 to 48 VDC systems)
 Power Consumption: (18 to 60) VA, (15 to 25) W - depending on the meter's hardware configuration; Max 60 VA, 25W
 Connection:..... 3 Pin 0.300" Pluggable Terminal Block
 Torque:3.5 Lb-In
 AWG#12-24, Solid or Stranded



For the AC power supply, use 500 V, 3 A time delay fuse, for the 24 V DC power supply use 7 A time delay fuse.

VOLTAGE INPUTS

UL Measurement Category: Category III
 Range:..... Universal, Auto-ranging:
 Phase to Neutral (Va, Vb, Vc, Vaux to Neutral): (5 - 347) VAC
 Phase to Phase (Va to Vb, Vb to Vc, Vc to Va): (10 - 600) VAC
 Supported hookups: 3 Element Wye, 2.5 Element Wye, 2 Element Delta, 4 Wire Delta
 Input Impedance:..... 5 MOhm/Phase
 Burden: 0.072 VA/Phase Max at 600 Volts;
 0.003VA/Phase Max at 120 Volts
 Pickup Voltage:..... 5 VAC
 Connection: 6 Pin 0.600" Pluggable Terminal Block
 Torque: 5 Lb-in
 AWG#12 -24, Solid or Stranded
 Fault Withstand: Meets IEEE C37.90.1
 Reading: Programmable Full Scale to any PT Ratio
 Fuse: 600 V, 1/2 A fast-acting fuse

CURRENT INPUTS

Class 2: 1 A Nominal, 2 A Maximum
 Class 20: 5 A Nominal, 20 A Maximum
 Burden:..... 0.008 VA Per Phase Max at 20 Amps
 Pickup Current:..... 0.1% of nominal
 Connections: O Lug or U Lug electrical connection (Figure 4-1)
 Tighten with #2 Philips screwdriver
 Torque- 8 Lb-In
 Pass through wire, 0.177" / 4.5mm
 Maximum Diameter (Figure 4-2)
 Quick connect, 0.25" Male Tab (Figure 4-3)
 Current Surge Withstand:.... At 23 °C: 100 A/10 sec, 300 A/3 sec, 500 A/1 sec
 Reading: Programmable Full Scale to any CT Ratio
 Continuous Current Withstand:
 20 Amps; for sustained loads greater than 10 Amps use
 Pass-through wiring method (see *Chapter 4* for instructions).

FREQUENCY

Range:..... (42.5-69.9) Hz;
 (45-65) Hz for IEEE C37.118.2

OPTIONAL RS485 PORT SPECIFICATIONS

RS485 Transceiver; meets or exceeds EIA/TIA-485 Standard:
 Type:..... Two-wire, half duplex
 Min. Input Impedance:..... 96 kΩ
 Max. Output Current:..... ±60 mA

ISOLATION

All Inputs to Outputs are isolated to 2500 VAC.

ENVIRONMENTAL RATING

Operating:..... (-20 to +70) °C
 Storage:..... (-30 to +80) °C
 Humidity: up to 95% RH Non-condensing
 Pollution Degree:..... 2
 Altitude: Maximum Rated - 2000 M
 Under Altitude..... Protection Class: IP30

MEASUREMENT METHODS

Voltage, Current: True RMS

UPDATE RATE

High speed readings 1 cycle; and programmable for 2-20 cycles RMS
 Revenue-accurate readings 1 sec

COMMUNICATION

Standard	10/100BaseT Ethernet ANSI Optical Port USB 1.1/2.0 Port, Full speed
Optional, through I/O card slot	Dual RS485 Serial Ports Second 10/100 BaseT Ethernet or 100Base-FX Fiber Optic Ethernet
Protocols	Modbus RTU, Modbus ASCII, DNP 3.0, IEC 61850 (Software Options B,C,E,F), SNMP, IEEE 1588 PTP v2 protocol, SMTP, IEEE C37.118-2 PMU, HTTP
Com Port Baud Rate.....	9600 to 115200 bps
Com Port Address	1-247 - Modbus protocol 1-65535 - DNP protocol
Data Format.....	8 Bit, No Parity

MECHANICAL PARAMETERS

Dimensions: see <i>Chapter 3</i> .	
Weight:.....	3.9 lbs

2.8 Accuracy

For 23 °C +/- 5 °C, 3 Phase balanced Wye or Delta load, at 50 Hz or 60 Hz (as per order) accuracy is as follows:

Parameters	Accuracy	Range
Voltage	0.05% (1 s readings) 0.1% (2-20 cycle readings)	(45 to 347) V AC L-N (80 to 600) V AC L-L
Current	0.025% (1 s) 0.1% (2-20 cycle)	1% to 200% of Nominal Class 2: Nominal 1 A, max. 2 A Class 20: Nominal 5 A, max. 20 A
Energy	kWh 0.06% (1 s) kVAh 0.08% (1 s) kVARh 0.08% (1 s)	I: 1% to 200% of Nominal V: (45 to 347) V PF: +/- (0.5 to 1) lag/lead
Power	kW (Unity PF): 0.1% (2-20 cycle), 0.06% (1 s) kW (0.5 PF): 0.1% (2-20 cycle), 0.1% (1 s) kVA: 0.1% (2-20 cycle), 0.08% (1 s) kVAR (0.5 - 0.9 PF): 0.1% (2-20 cycle), 0.08% (1 s)	I: 1% to 200% of Nominal V: (45 to 347) V
Power Factor	0.08% (1 s) 0.1% (2-20 cycle)	
Frequency	0.001 Hz (10 s) 0.001 Hz (1 s) 0.03 - 0.001 Hz (2-20 cycles readings) 0.01 Hz (High resolution single cycle)	(42.5 to 69.9) Hz
	.01 Hz (PMU Frequency)	(45-65) Hz
Voltage/Current Unbalance ⁴	±0.05	0.5% to 5% u2 0.5% to 5% u0

Parameters	Accuracy	Range
Harmonic/ Interharmonic	0.2% (1 s)	
Voltage Sag/Swell Duration Depth ²	½ cycle ±0.1% U _{din}	4.97 hours maximum 10% to 150% U _{din}
Interruption duration	½ cycle	4.97 hour maximum
Rapid voltage Change (RVC) Duration U _{max} ² U _{ss} ⁴	½ cycle ±0.1% U _{din} ±0.1% U _{din}	4.97 hours maximum 10% to 150% U _{din} 10% to 150% U _{din}
Mains Signaling voltage ^{1,3}	±5% U _m U _m ≥ 1% U _{nom} ±0.05% U _{nom} U _m < 1% U _{nom}	10% to 200% of Class 3 electromagnetic environment in IEC 61000-2-4
Flicker	5% of reading	Pst: 0.2 to 10
Temperature		(-20 to +70) °C
Real Time Clock	3.5 ppm	
Timestamp (IRIG sync)	1 usec typical; 100 usec max	

1 – U_m (measured value), U_{nom} (nominal voltage range).

2 - U_{din} (declared input voltage): value obtained from the declared supply voltage by a transducer ratio.

3 - Because data is computed from interharmonics bins, error and range follow interharmonics.

4 - u₂ (negative sequence), u₀ (zero sequence).

*1 s = 1 second; for 100 millisecond updates, set the High Speed readings update rate to 6 cycles @ 60 Hz or 5 cycles @ 50 Hz.

2.9 Standards Compliance

- ANSI C12.20 - 0.2 Accuracy Class and C12.1 2008; 0.2 CL (MET Labs Certified)*
- ANSI C62.41 (Burst)
- FCC Part 15, Class A (Radiated and Conducted Emissions)*
- IEC 62053-22 - Accuracy, 0.2S (KEMA Labs Certified)
- IEC 62053-23 Ed.1
- CE (EN/IEC 61326-1 & EN/IEC 61000-3-2 & EN/IEC 61000-3-3) Certified*
 - IEC 61000-4-2 Ed. 2 2008 (Electrostatic Discharge)*
 - IEC 61000-4-3 Ed. 3.2 2010 (Radiated EM Immunity)*
 - IEC/EN 61000-4-4 Ed.3 2012, Class B (EFT)*
 - IEC/EN 61000-4-5, Class B (Surge Immunity)*
 - IEC 61000-4-6 Ed. 3 2008 (Conducted Immunity)*
 - IEC 61000-4-8 Ed. 2 2009 (Magnetic Immunity)*
 - IEC 61000-4-11 Ed. 2 2004 (Voltage Variations Immunity)*
- IEC 61000-4-30 Class A Ed.3 Certified*
 - IEC 61000-2-4 (Compatibility Levels)*
 - IEC 62586-2 Ed. 2 2013 (PQ Measurement in Power Supply Systems)*
 - IEC 61000-4-7 Ed. 2 2002 (Harmonics)*
 - IEC 61000-4-15 Ed. 2 2010 (Flicker Meter)*
- IEC 61000-6-2 2005 (Immunity for Industrial Environments)
- IEC 61000-6-4 2006 (Emissions Standards for Industrial Environments)
- IEC 61850 Level A, Ed. 2 Certified*
- CISPR11 Ed. 5.1 (Conducted Emissions)*
- CISPR22 Class A*
 - IEC 62052-11 2003- General Requirements*
- EU Directive 2011/65/EU (RoHS 3 Directive)
- Certified to UL/IEC 61010-1 and CSAC22.2 No. 61010-1, UL File: E200431

* Third party lab tested standards testing. Test reports may be cross-branded product equivalents.

Test	Reference Standard	Level/Class
Electrostatic Discharge	EN/IEC61000-4-2	Level 3
RF immunity	EN/IEC61000-4-3	10 V/m
Fast Transient Disturbance	EN/IEC61000-4-4	Level 3
Surge Immunity	EN/IEC61000-4-5	Level 3
Conducted RF Immunity	EN/IEC61000-4-6	Level 3
Radiated & Conducted Emissions	EN/IEC61000-6-4/ CISPR 11	Class A

Test	Reference Standard	Level/Class
Power magnetic frequency	EN/IEC61000-4-8	Level 4
Voltage Dip & interruption	EN/IEC61000-4-11	0, 40, 70, 80% dips, 250/ 300 cycle interrupts
Flicker Meter	EN/IEC61000-4-15	
Power quality measurement	En/IEC61000-4-30	Class A
Harmonics	EN/IEC61000-4-7	Class A

Multilin™ EPM 9900P

Chapter 3: Mechanical Installation

This chapter explains how to install the EPM 9900P meter. For installation instructions on the optional I/O cards and external modules, see Chapter 11 *Using the I/O Options*.

3.1 Mounting the EPM 9900P Meter

The EPM 9900P meter is designed to mount in a panel. Refer to Section 3.2 for meter and panel cut-out dimensions, and Section 3.3 for mounting instructions.

The EPM 9900P meter is mounted in a panel. The various models use the same installation. See Chapter 4 *Electrical Installation* for wiring diagrams.



NOTE

The figures shown in this chapter depict horizontal installation, but you can also mount the meter vertically. You can then rotate the display screens to support vertical installation (see Chapter 6 *Using the EPM 9900P Meter's Touch Screen Display* for instructions).

To clean the unit, wipe it with a clean, dry cloth.

3.2 Meter and Panel Cut-out Dimensions

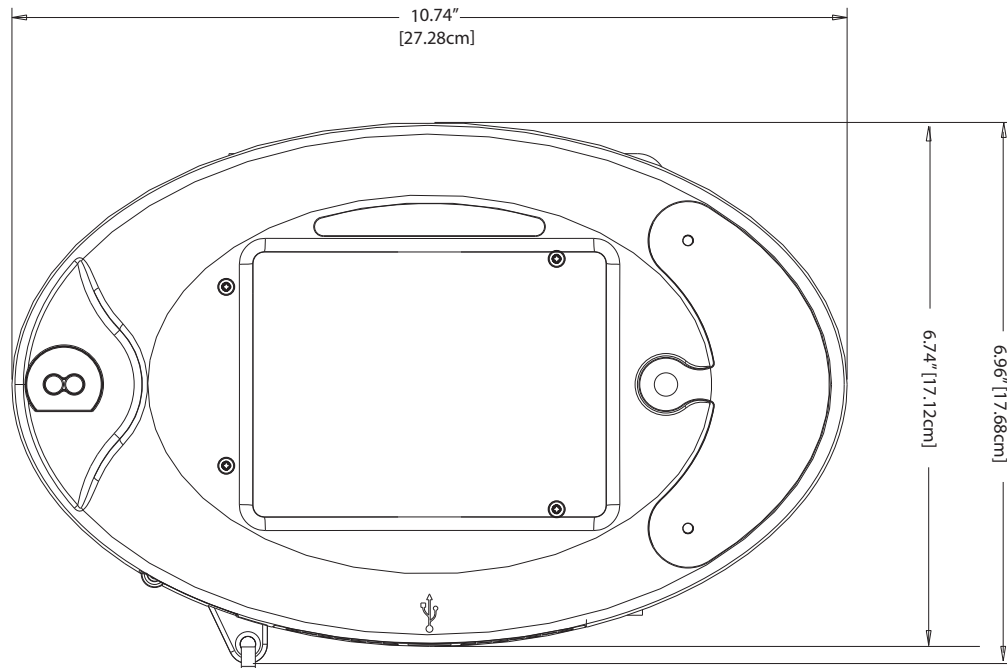

Figure 3-1: Meter Dimensions (Front)

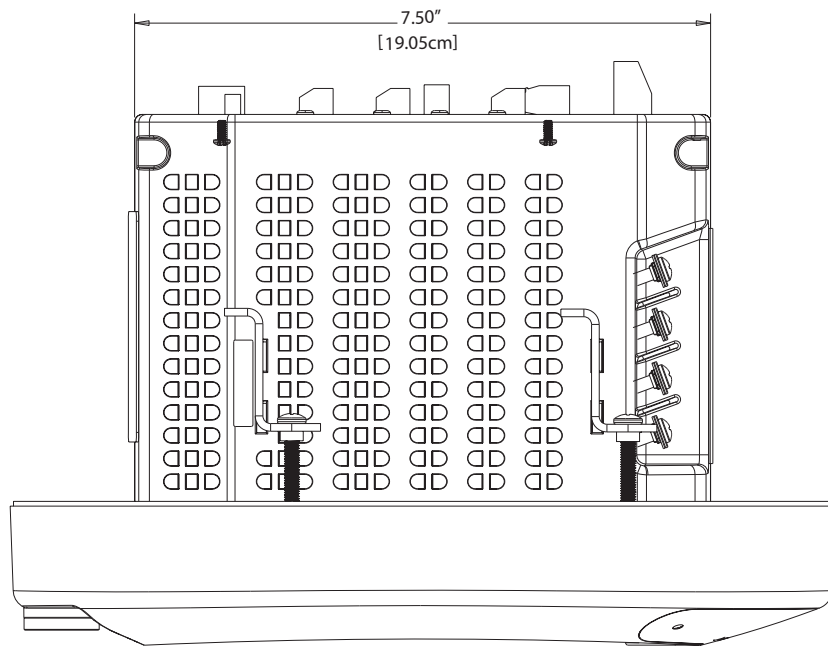

Figure 3-2: Meter Top View

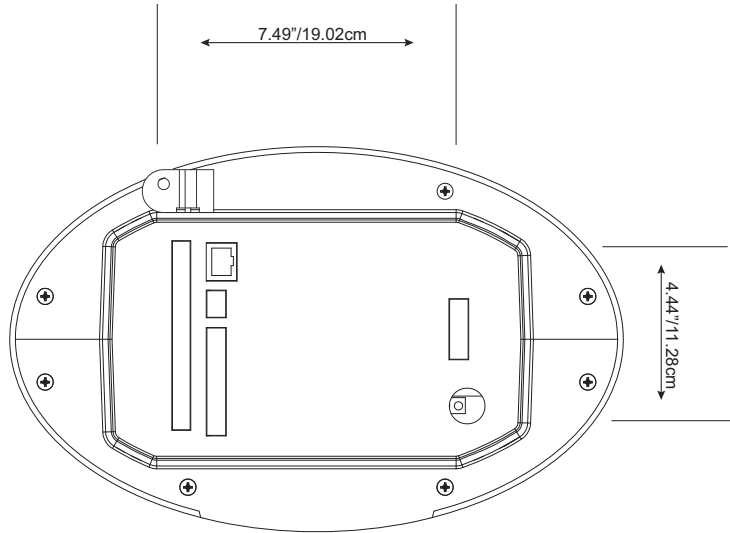

Figure 3-3: Meter Back View

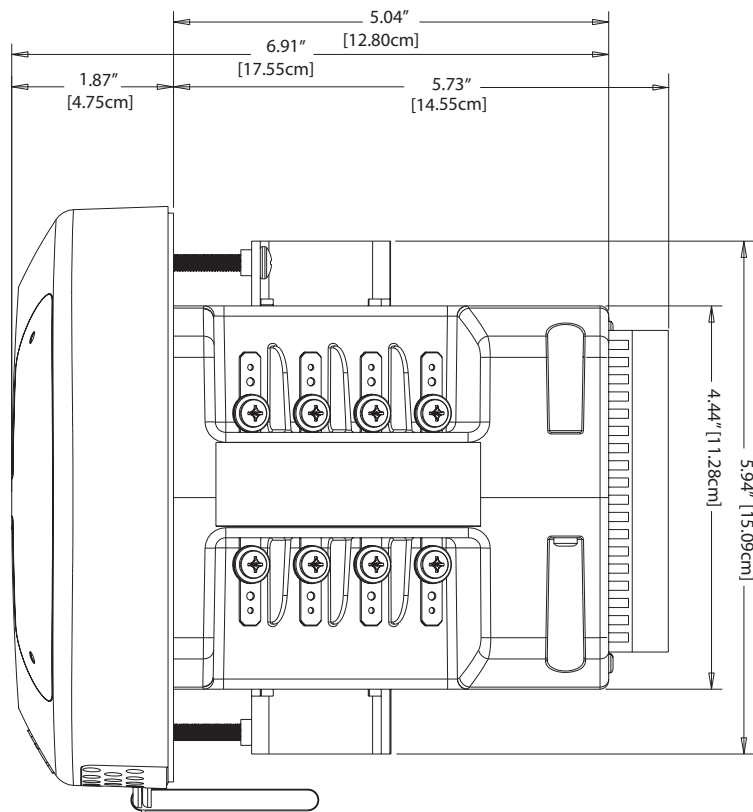

Figure 3-4: Meter Side View

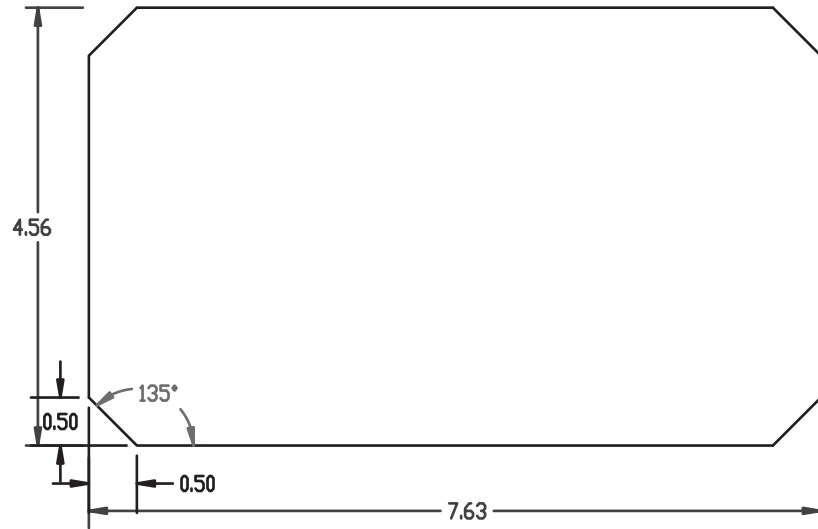

Figure 3-5: Optional Octagonal Cutout Dimensions

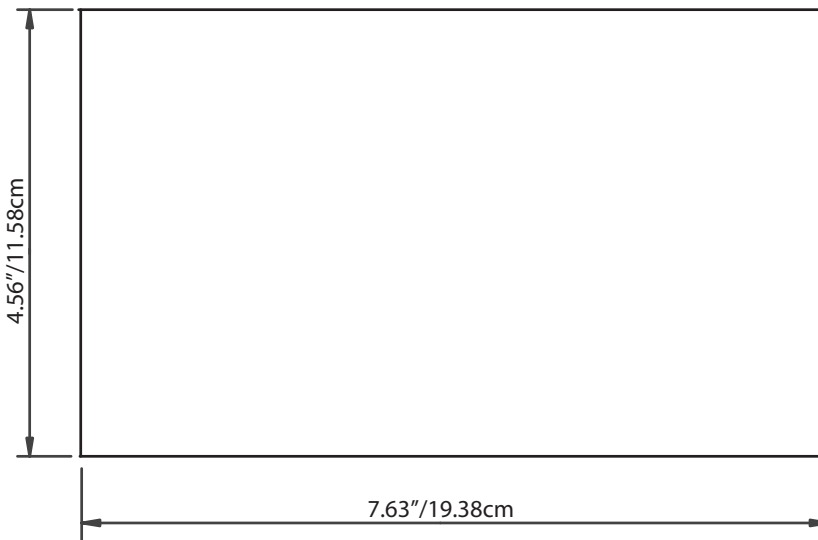
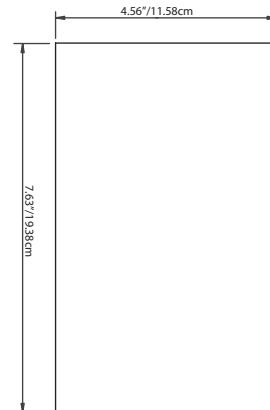
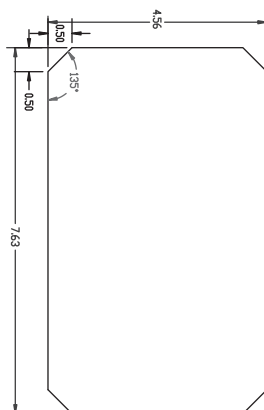

Figure 3-6: Optional Rectangular Cutout Dimensions



These cut-outs can also be made in a vertical orientation, with the longer dimensions on the side, for vertical mounting of the meter.



3.3 Mounting Instructions

1. Slide the meter into the panel.



NOTE

Note that you can mount the meter either horizontally or vertically.

2. From the back of the panel, slide 4 mounting brackets into the grooves on the top and bottom of the meter housing (2 fit on the top and 2 fit on the bottom). If you are mounting vertically, the brackets fit on either side (2 on each side).
3. Snap the mounting brackets into place.
4. Secure the meter to the panel with lock washer and a #8 screw in each of the 4 mounting brackets (see Figure 3.4).
5. Tighten the screws with a #2 Phillips screwdriver. Do not over-tighten. Maximum installation torque is 3.5 lb-in.



NOTE

If necessary, replacement mounting brackets (part number PL9000MBIO00000) may be purchased from GE Grid Solutions.

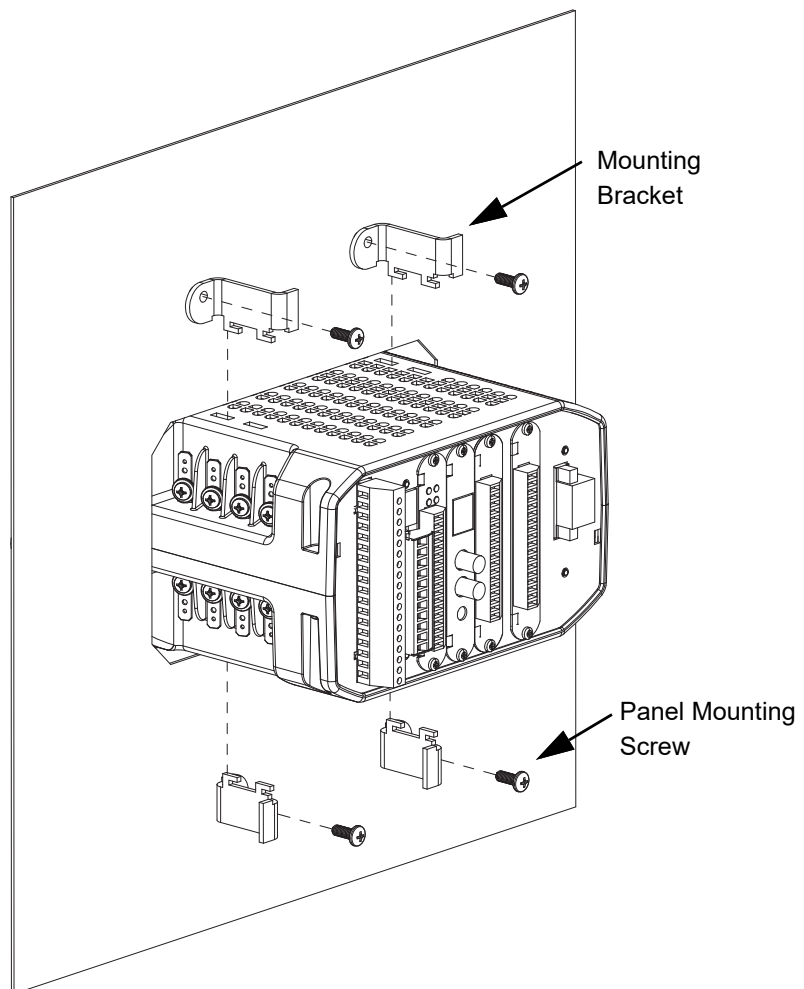

Figure 3-7: Mounting the Meter Horizontally

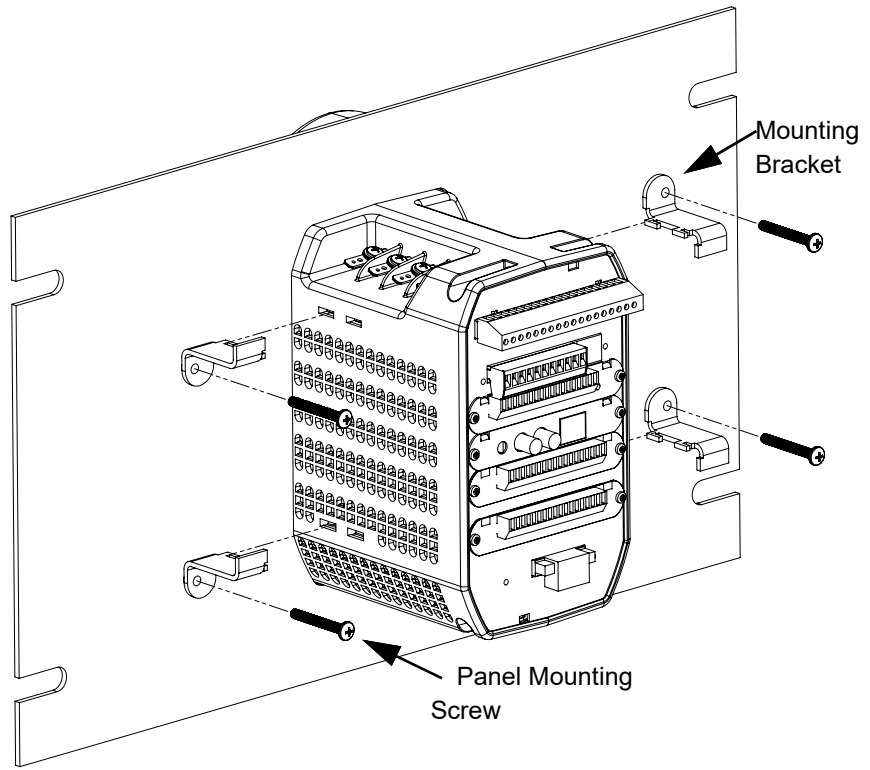

Figure 3-8: Mounting the Meter Vertically

3.4 Replacing the Meter's Battery

This section gives instructions for replacing the meter's Lithium battery.

CAUTION

CAUTION! All personnel opening the EPM 9900P meters are required to be aware of the ESD threat to the electronic components and are required to maintain ESD prevention measures.

You will need the following tools for the job:

- Ultra-grip static-dissipative screwdriver Phillips round blade, #1 tip, 3-1/8" blade length
- Phillips power bit 1/4" hex shank, tip #1, 2" length
- Torque set screw driver: torque settings on drill 10in-lbs.
- ESD rigid plastic tweezers, 4 1/2".
- Battery insertion tool: 3 1/4" width x 3" length, non-conductive plastic.
- Non-metallic latex gloves.



NOTE

Save all hardware (screws, washer, etc.) during disassembly, as it will be needed during the reassembly of the unit.

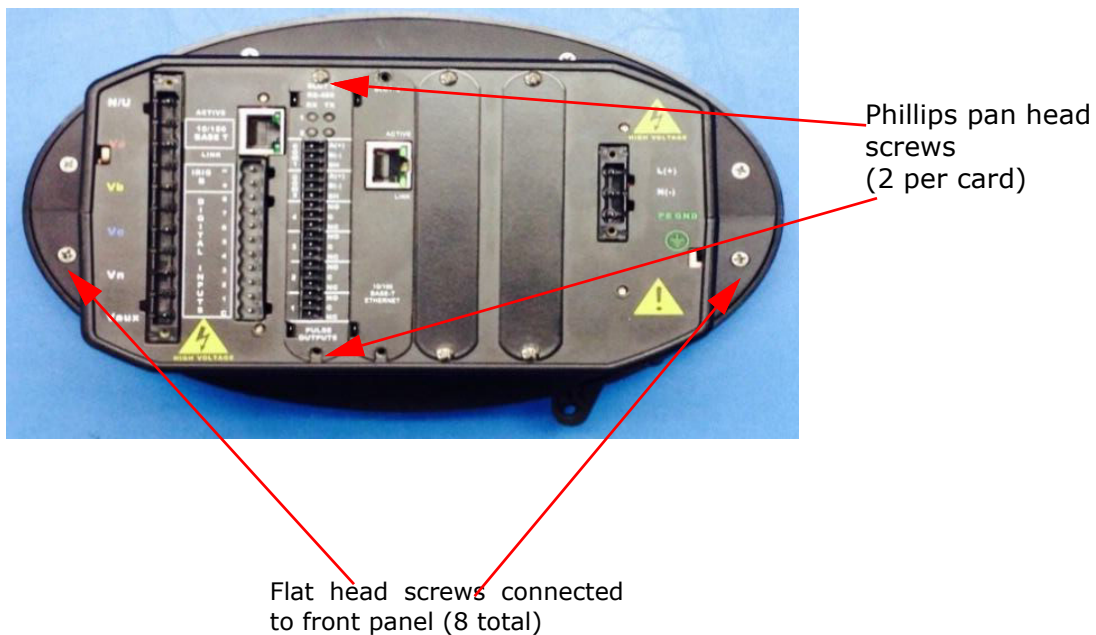

Figure 3-9: Location of Meter Screws

Follow this procedure:

1. Turn the meter over and remove all of the option cards. Each option card is secured with two ¼ Phillips pan head screws (see *Using the I/O Options* on page 11-1). Refer to Figure 3-9.

NOTICE

Take note of the slot where each option card is installed. When reassembling the unit the option cards must be placed in the same slot from which they were removed.

2. Remove the eight flat head screws connected to the front panel.
3. With the eight flat head screws removed, carefully separate the front panel from the body of the unit.
4. Remove the digital board insulator - see Figure 3-10.

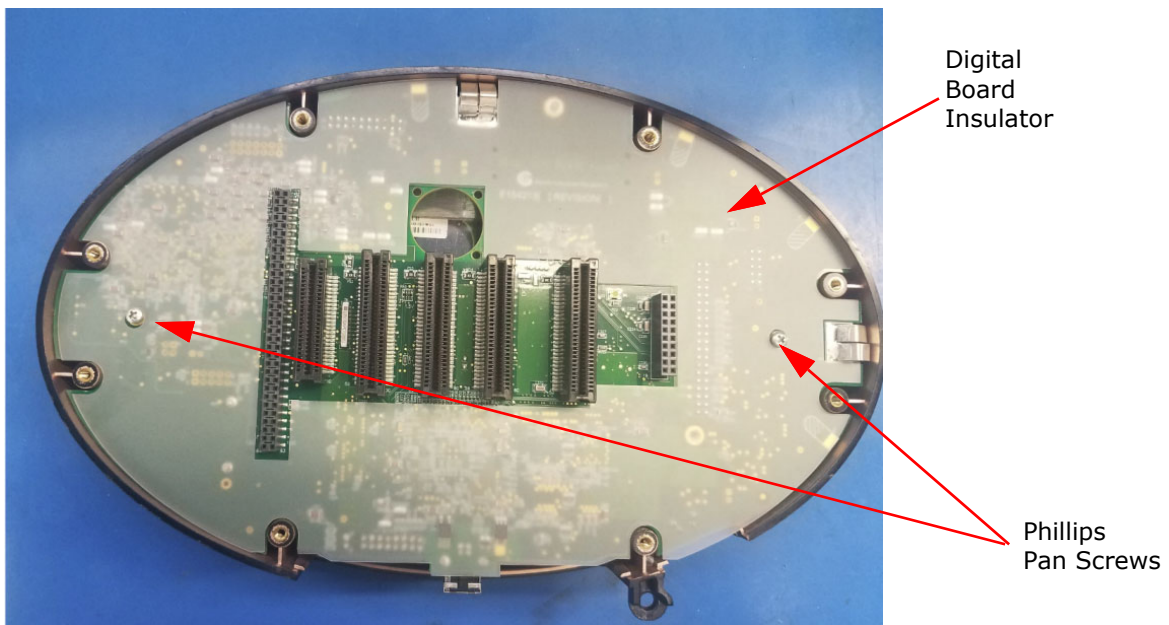

Figure 3-10: Inside of Meter Showing the Digital Board Insulator

5. Remove the two Phillips pan screws used to mount the digital board on the front panel. See Figure 3-10

6. With one hand on the front panel and the other on the digital board, carefully separate the front panel from the digital board. See Figures 3-11 and 3-12.

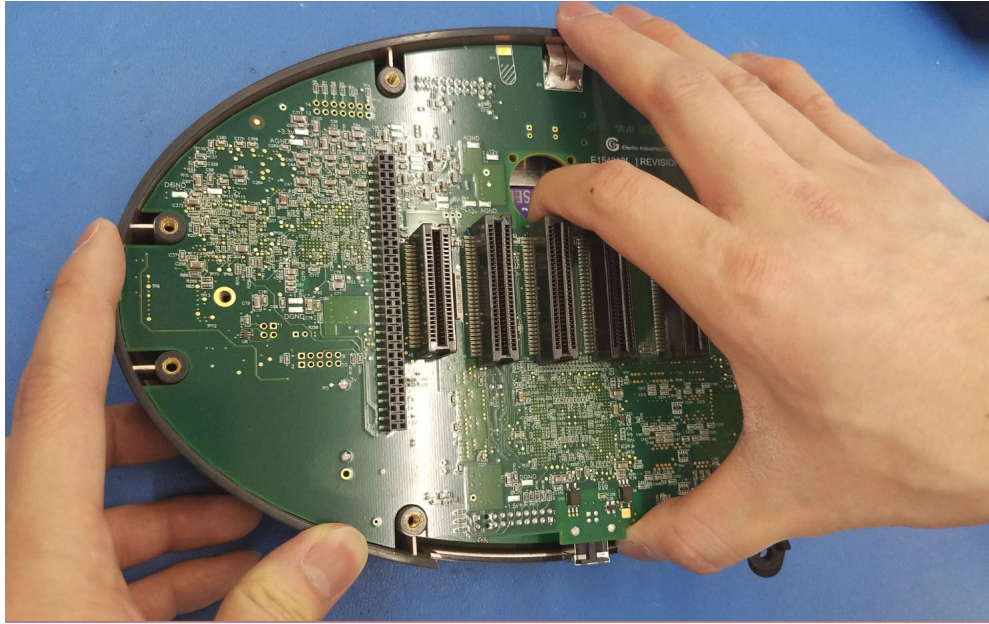

Figure 3-11: Holding the Front Panel and Digital Board

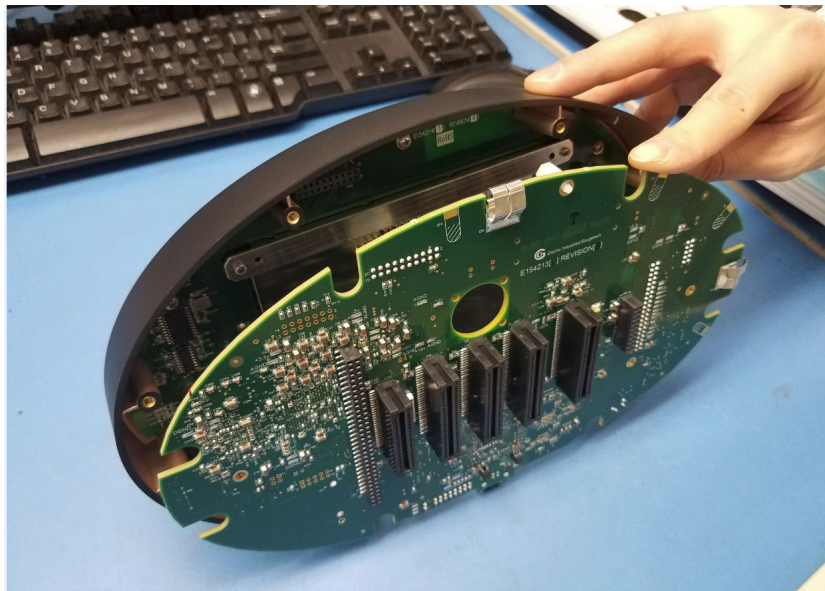

Figure 3-12: Separating the Front Panel from the Digital Board

7. Turn the digital board so that the battery is facing you - see Figure 3-13

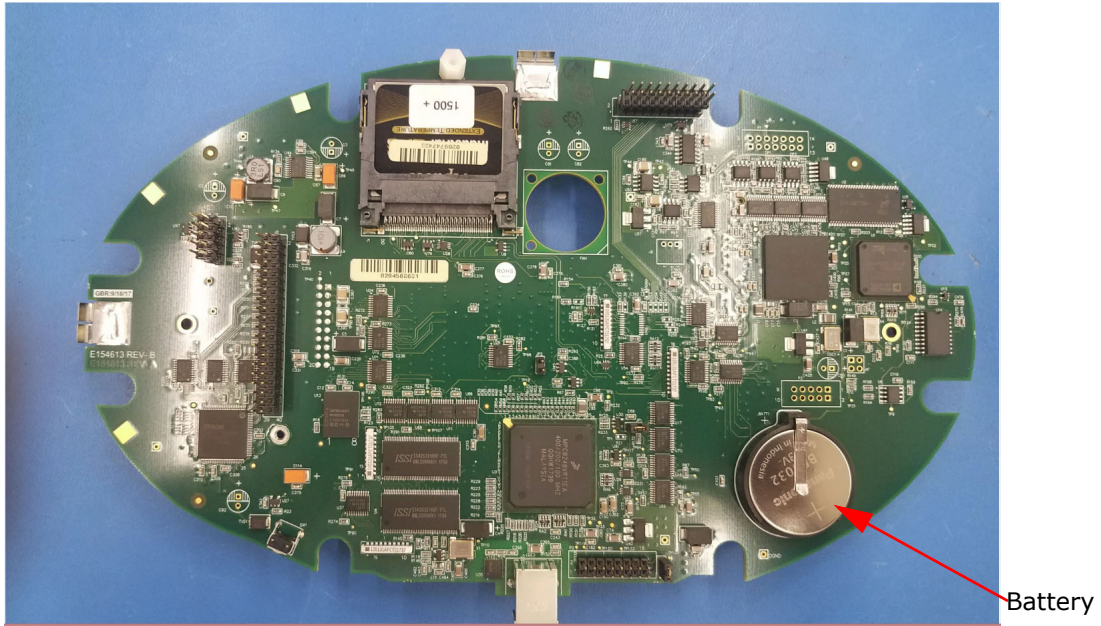

Figure 3-13: Location of Battery

8. To remove the battery, (Manufacturer Part #: Panasonic Battery BR 3032 3V Lithium Coin Size Battery), first slide the battery insertion tool under the battery between the negative pole of the battery and the battery holder. See Figure 3-14.

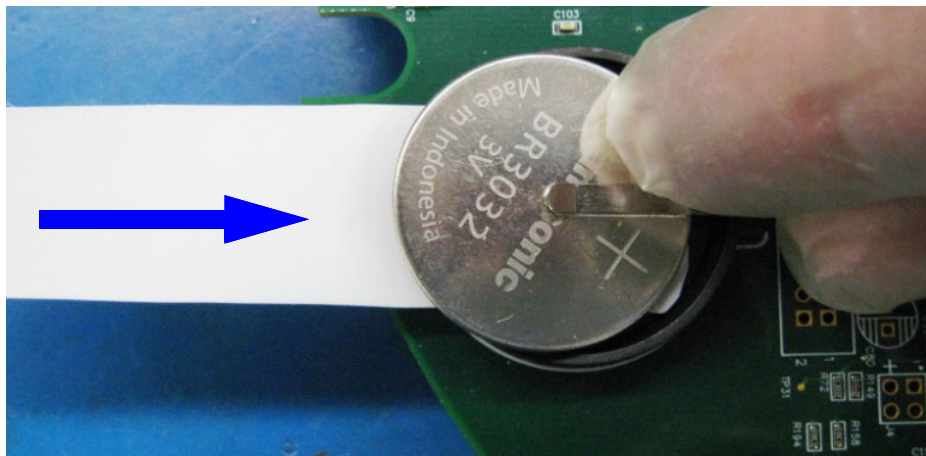

Figure 3-14: Positioning the Battery Insertion Tool

- Using a gloved hand/finger, gently slide the battery out of the holder and along the battery insertion tool. See Figure 3-15.

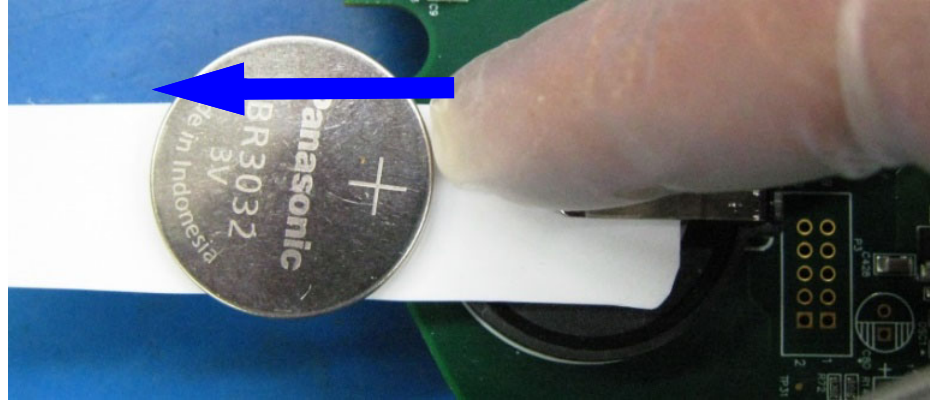

Figure 3-15: Sliding the Battery Out

- Dispose of the battery properly.
- Slide the battery insertion tool between the positive (+) tab and the negative tab (NEG) of the battery holder. See Figure 3-16.

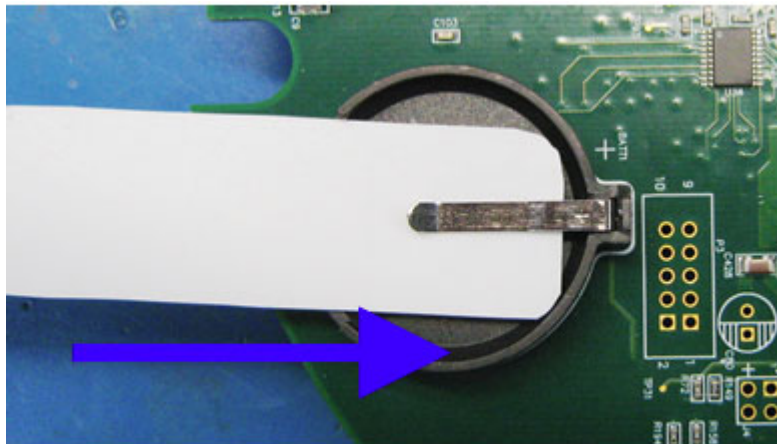

Figure 3-16: Placement of Battery Insertion Tool

12. Use a non-conductive tweezer to gently lift the Positive (+) tab up. See Figure 3-17.

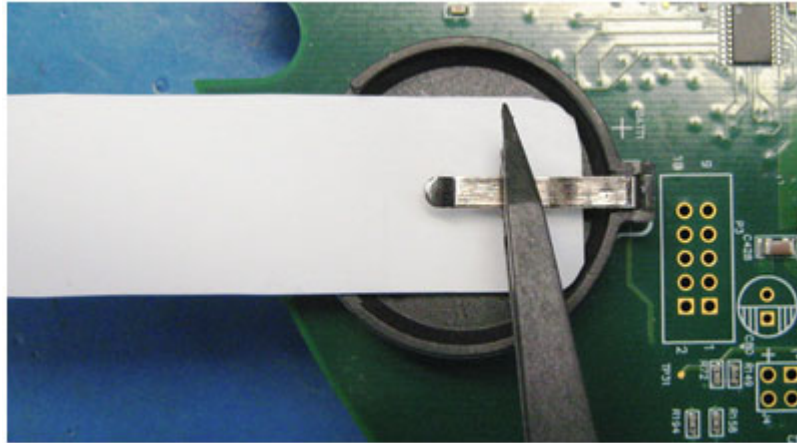

Figure 3-17: Lifting the Positive Tab

NOTICE

Always keep the plus (+) side of the battery up.

13. Using a gloved hand and observing the correct battery polarity (plus (+) side up), gently slide the battery under the Positive (+) tab. Push the battery all the way into the battery holder. See Figure 3-18.

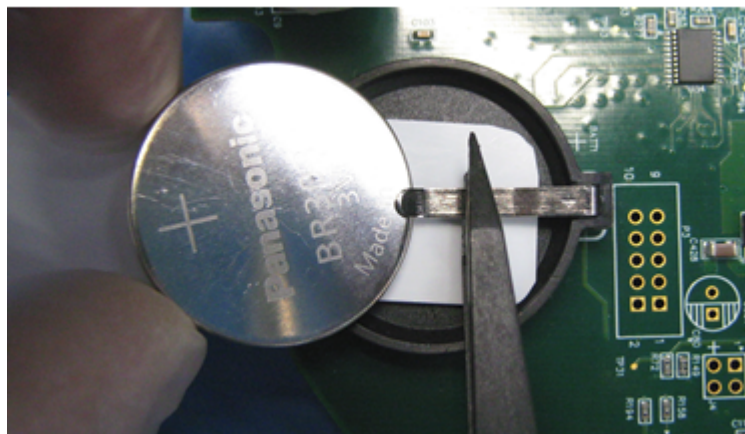

Figure 3-18: Inserting the Battery

14. Gently pull the battery insertion tool out from under the installed battery and make sure the battery is fully installed into the holder. See Figure 3-19

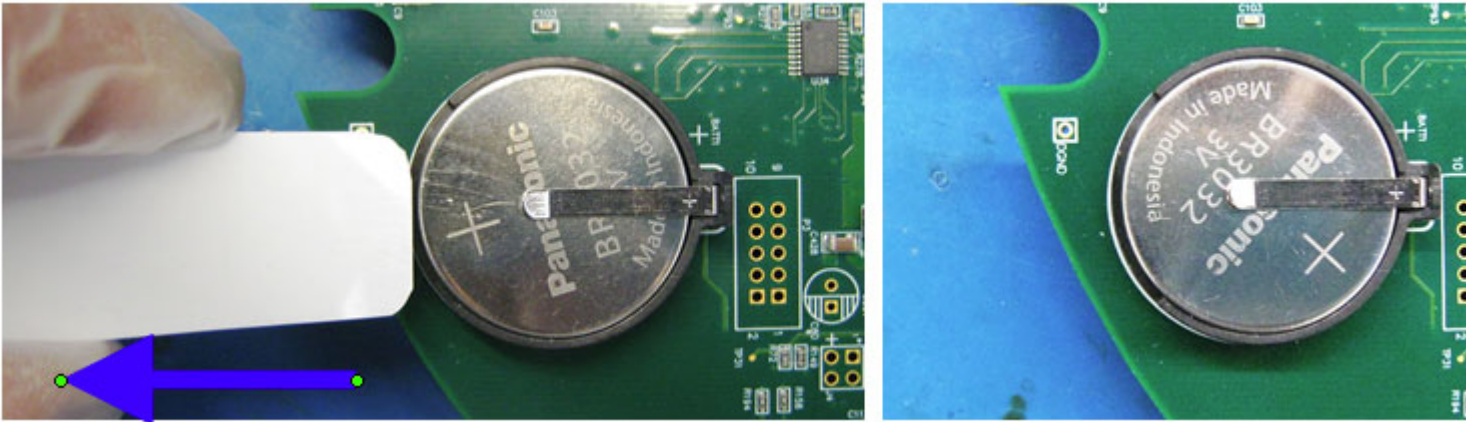

Figure 3-19: Removing the Battery Insertion tool and Battery Installed Correctly

15. Check that the digital board headers have no bent pins, and then align the headers and connectors of the digital board and the front panel board. Carefully push the main digital board on to the front panel display making sure the connectors are aligned. Once fully seated, secure the main digital board to the front panel using two pan head screws. See Figure 3-20.

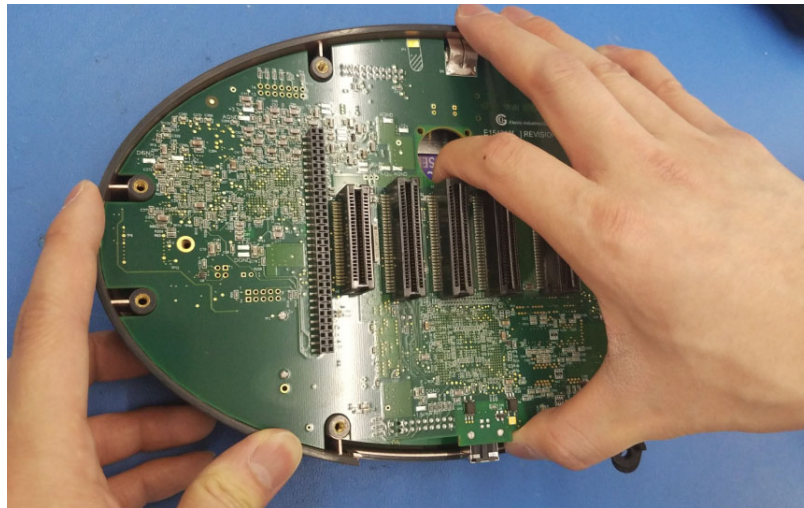

Figure 3-20: Aligning the Digital Board and the Front Panel Board

16. Place the digital board insulator on the digital board as shown in Figure 3-21. The EMI shielding tabs of the digital board should be placed within the boundaries of the front panel shell, not on the outer surface of the front panel shell.

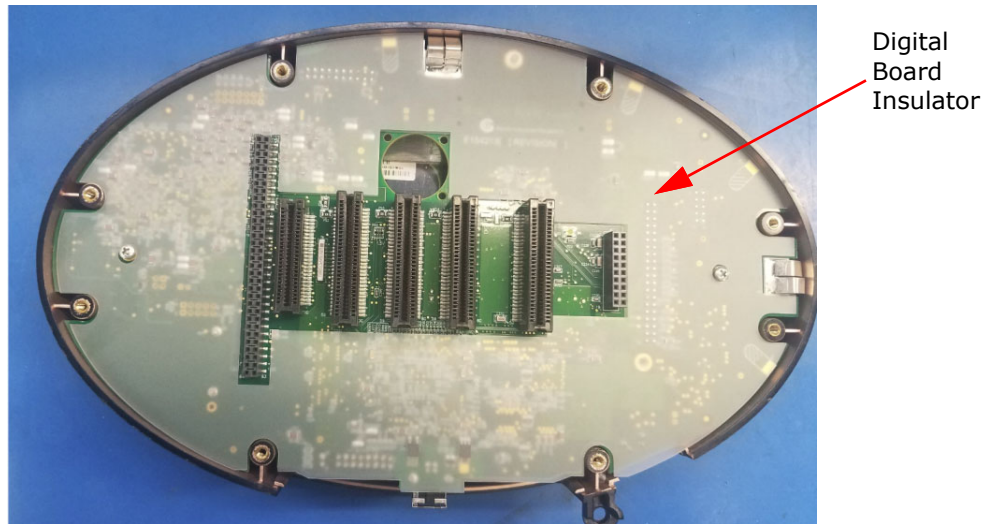

Figure 3-21: Replacing the Digital Board Insulator

17. Align the base of the meter with the front panel assembly. Be sure that the connectors from the power supply and the analog board are aligned and inserted correctly into the main digital board. Carefully push the two assemblies together until fully seated. Secure the base unit to the front panel assembly with the eight flat head screws that were removed in Step 2.
18. Reinstall each option card back into the same slot from which it was removed. Be sure the option card(s) is fully seated in the connector, then secure with the two pan head screws that were removed in Step 1.
19. Check that all screws are tight and that no extra hardware is left over.

Multilin™ EPM 9900P

Chapter 4: Electrical Installation

4.1 Safety Considerations When Installing Meters

CAUTION

- Installation of the EPM 9900P meter must be performed only by qualified personnel who follow standard safety precautions during all procedures. Those personnel should have appropriate training and experience with high voltage devices. Appropriate safety gloves, safety glasses and protective clothing are recommended.
- During normal operation of the EPM 9900P meter, dangerous voltages flow through many parts of the meter, including: Terminals and any connected CTs (Current Transformers) and PTs (Potential Transformers), all I/O (Inputs and Outputs) and their circuits. All Primary and Secondary circuits can, at times, produce lethal voltages and currents. Avoid contact with any current-carrying surfaces.
- **Do not use the meter for primary protection or in an energy-limiting capacity. The meter can only be used as secondary protection.**
- Do not use the meter for applications where failure of the meter may cause harm or death.
- Do not use the meter for any application where there may be a risk of fire.
- All meter terminals should be inaccessible after installation.
- Do not apply more than the maximum voltage that the meter or any attached device can withstand. Refer to meter and/or device labels and to the Specifications for all devices before applying voltages.
- Do not HIPOT/Dielectric test any Outputs, Inputs or Communications terminals.
- To prevent hazardous voltage conditions, the use of fuse branch circuit protection for voltage leads and the power supply are required.
To prevent CT damage and potential injuries, shorting blocks for CT circuits are required if the meter needs to be removed from service. One side of the CT must be grounded.



The current inputs are only to be connected to external current transformers provided by the installer. The CTs shall be Approved or Certified and rated for the current of the meter used.

- Branch circuit protection size should be 15 Amps.
- For sustained loads greater than 10 Amps, the CT wires should be wired directly through the CT opening (pass through wiring method - see *CT Leads with No Meter Termination (Pass Through)*, using 10 AWG wire.



- **IF THE EQUIPMENT IS USED IN A MANNER NOT SPECIFIED BY THE MANUFACTURER, THE PROTECTION PROVIDED BY THE EQUIPMENT MAY BE IMPAIRED.**



- **ANY REPAIR OR MAINTENANCE SHOULD BE PERFORMED BY THE FACTORY.**



- **DISCONNECT DEVICE:** The following part is considered the equipment disconnect device. A SWITCH OR CIRCUIT-BREAKER SHALL BE INCLUDED IN THE END-USE EQUIPMENT OR BUILDING INSTALLATION. THE SWITCH SHALL BE IN CLOSE PROXIMITY TO THE EQUIPMENT AND WITHIN EASY REACH OF THE OPERATOR. THE SWITCH SHALL BE MARKED AS THE DISCONNECTING DEVICE FOR THE EQUIPMENT.

4.2 CT Leads Terminated to Meter

The EPM 9900P meter measures current using traditional 5 A secondary or 1 A secondary current transformers. These transformers step down the primary current to a range that they meter and sense.

The EPM 9900P meter is designed to have current inputs wired in one of three ways. Figure 4-1 shows the most typical connection where CT Leads are terminated to the meter at the current gills. This connection uses nickel-plated brass rods with screws at each end. This connection allows the CT wires to be terminated using either an "O" or a "U" lug. Tighten the screws with a #2 Phillips screwdriver (Torque- 8 Lb-In).

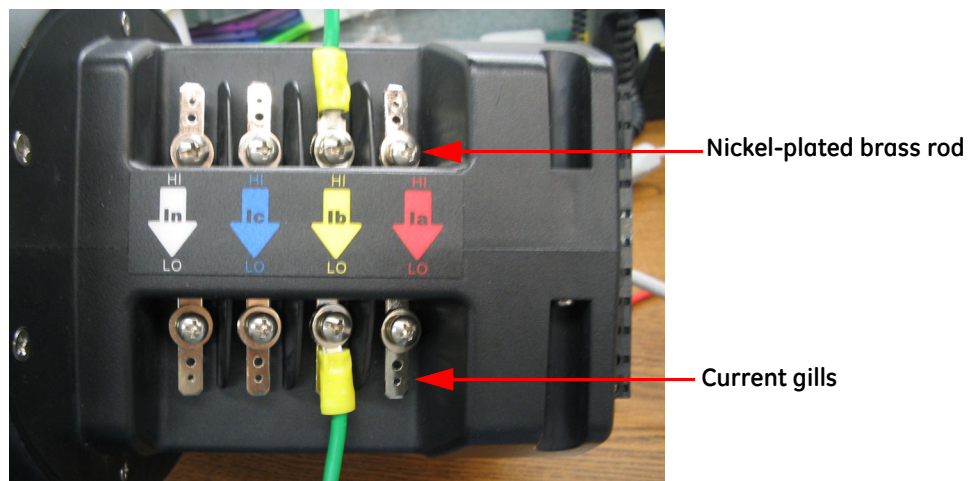

Figure 4-1: CT Leads terminated to Meter, #8 Screw for Lug Connection

Other current connections are shown in sections 4.2 and 4.3. Voltage and RS485/KYZ connections can be seen in Figure 4-4.

Wiring diagrams are shown in section 4.6 of this chapter; Communications connections are detailed in Chapter 5 *Communication Wiring*.

NOTICE

For sustained loads greater than 10 Amps, use the pass through wiring method (Section 4.3), using 10 AWG wire.

4.3 CT Leads with No Meter Termination (Pass Through)

The second method allows the CT wires to pass through the CT inputs without terminating at the meter. In this case, remove the current gills and place the CT wire directly through the CT opening. The opening accommodates up to 0.177"/4.5mm maximum diameter CT wire.

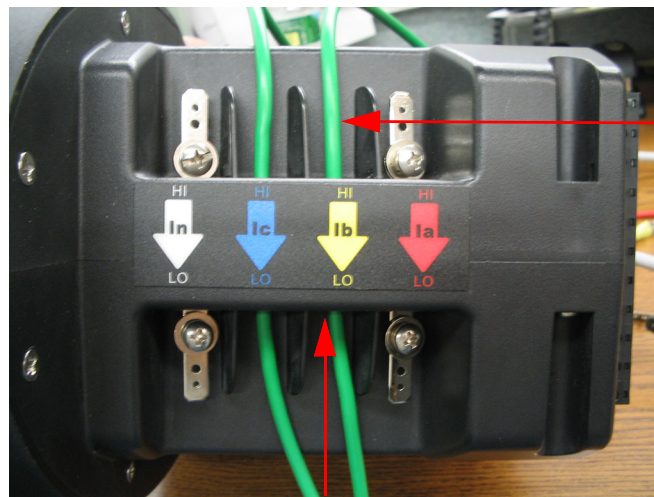

CT wire passing through meter with current gills removed

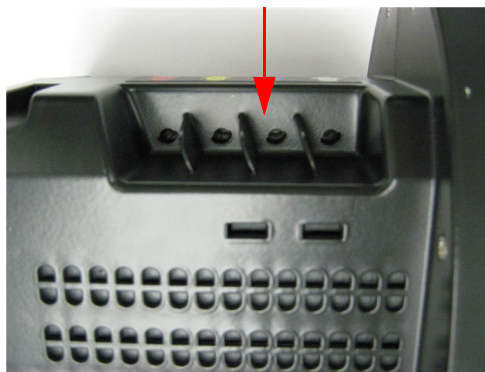

Close-up of CT openings

Figure 4-2: Pass Through Wire Electrical Connection

NOTICE

For sustained loads greater than 10 Amps, use 10 AWG wire.

4.4 Quick Connect Crimp-on Terminations

You can use 0.25" Quick Connect Crimp-on connectors for quick termination or for portable applications.

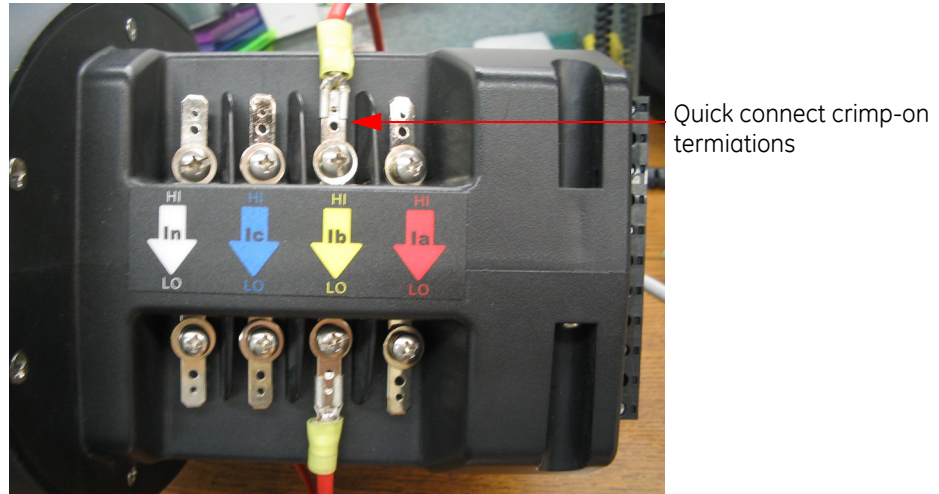

Figure 4-3: Quick Connect Electrical Connection

NOTICE

For sustained loads greater than 10 Amps, use pass through wiring method (Section 4.3), using 10 AWG wire.

4.5 EPM 9900P Monitored Inputs

The figure below shows the EPM 9900P meter inputs, and the following sections provide further details. Note that I/O is also displayed, for clarity,

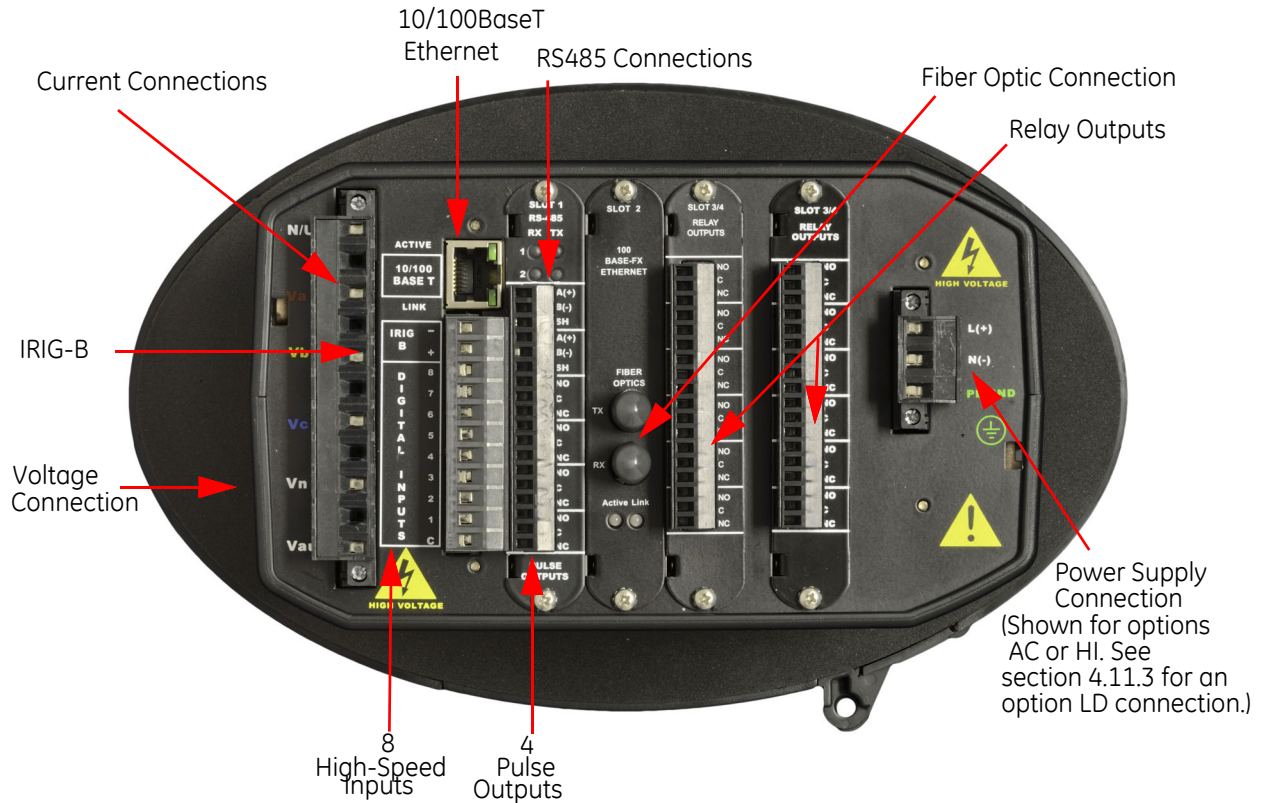

Figure 4-4: EPM 9900P Meter Inputs and Outputs

4.5.1 Voltage Inputs

Select a wiring diagram from section 4.6 *Wiring Diagrams* that best suits your application and wire the meter exactly as shown. For proper operation, the voltage connection must be maintained and must correspond to the correct terminal. Program the CT and PT ratios in the Device Profile section of the GE Communicator software; see the *GE Communicator Instruction Manual* for details.

Wiring the Voltage Inputs

- The cable required to terminate the voltage sense circuit should have an insulation rating greater than 600VAC and a current rating greater than 0.1 A.
- Wire type: Solid or stranded
- Wire gauge: 12-24 AWG for either solid or stranded wire
- Strip length: 7-8 mm
- Torque: 5 Lb-In

Fusing the Voltage Connections

For accuracy of the readings and for protection, GE requires using 0.1 Amp rated fuses on all voltage inputs.

The EPM 9900P meter allows measurement up to a nominal 347VAC phase to neutral and up to 600VAC phase to phase. Potential Transformers (PTs) are required for higher voltages to insure proper safety.

Use a 4 Amp slow blow fuse on the power supply for control power.

4.5.2 Wiring the Monitored Inputs - Vaux

The Voltage Auxiliary (Vaux) connection is an auxiliary voltage input that can be used for any desired purpose, such as monitoring two different lines on a switch. The Vaux Voltage rating is the same as the metering Voltage input connections.

4.5.3 Ground Connections

The meter's PE GND terminal should be connected directly to the installation's protective earth ground. Use AWG#12/2.5 mm² wire for this connection.

4.5.4 Current Inputs

Program the CT ratios in the Device Profile section of the GE Communicator software; see the *GE Communicator Instruction Manual* for details.

Wiring the Monitored Inputs - Currents

Mount the current transformers (CTs) as close as possible to the meter. The following table illustrates the maximum recommended distances for various CT sizes, assuming the connection is via 14 AWG cable.

GE Grid Solutions Recommendations

CT Size (VA)	Maximum distance from CT to EPM 9900P Meter (Feet)
2.5	10
5	15
7.5	30
10	40
15	60
30	120



DO NOT leave the secondary of the CT open when primary current is flowing.

This may cause high voltage on open secondary CT which could be potentially lethal to humans and destructive to equipment itself.

If the CT is not connected, provide a shorting block on the secondary of the CT.

It is important to maintain the polarity of the CT circuit when connecting to the EPM 9900P meter. If the polarity is reversed, the meter will not provide accurate readings. CT polarities are dependent upon correct connection of CT leads and the direction CTs are facing when clamped around the conductors. Although shorting blocks are not required for proper meter operation, GE recommends using shorting blocks to allow removal of the EPM 9900P meter from an energized circuit, if necessary.

Isolating a CT Connection Reversal

For a Wye System, you may either:

- Check the current phase angle reading on the EPM 9900P meter's display (see Chapter 6 *Using the EPM 9900P Meter's Touch Screen Display*). If it is negative, reverse the CTs.
- Go to the Phasors screen of the GE Communicator software (see the *GE Communicator Instruction Manual* for instructions). Note the phase relationship between the current and voltage: they should be in phase with each other.

For a Delta System:

Go to the Phasors screen of the GE Communicator software program (see the *GE Communicator Instruction Manual* for instructions). The current should be 30 degrees off the phase-to-phase voltage.

4.5.5 Instrument Power Supply Connections

- Wire gauge: 12-18 AWG for either solid or stranded wire
- Torque: 3.5 Lb-In
- Branch circuit protection size should be 15 A.

The EPM 9900P meter requires a separate power source. There are three optional power supplies: AC, HI High-Voltage, and LD Low-Voltage.



The power supply connections vary depending on the power supply option being used. CAREFULLY follow the instructions and drawings in this section for proper wiring.

AC Power Supply

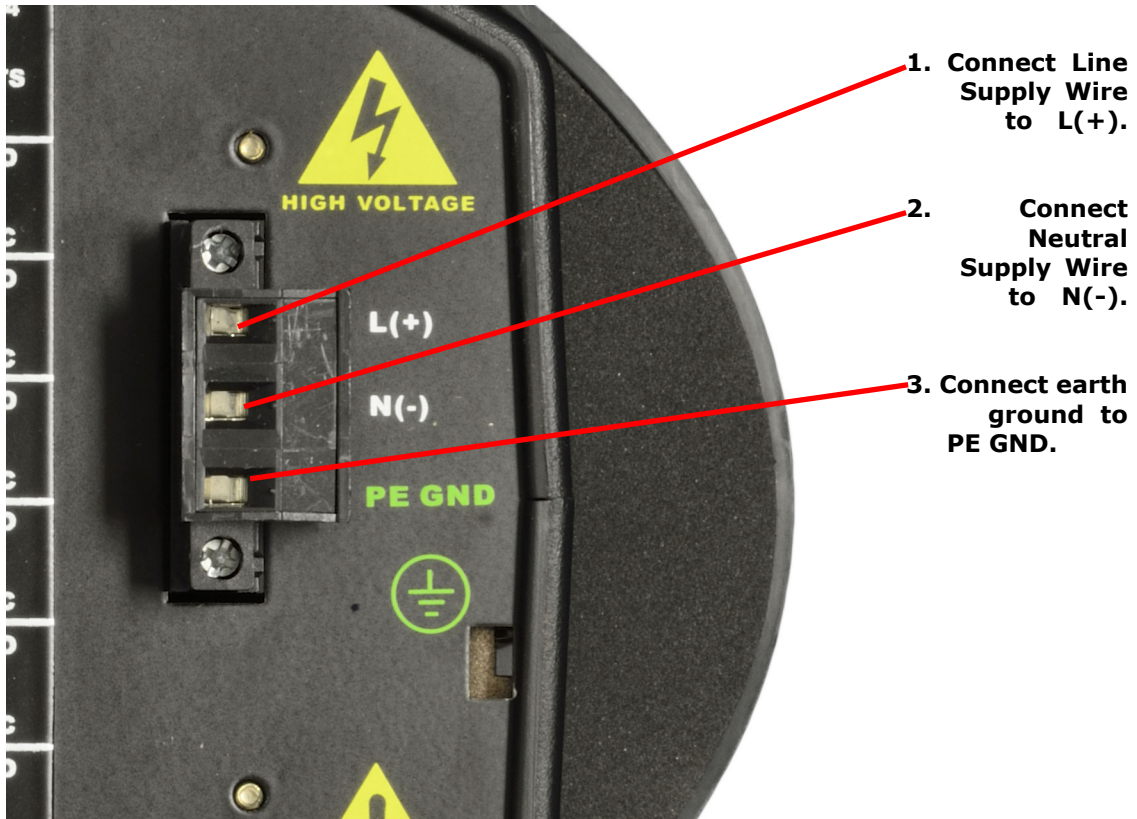

For the AC Option power supply:

1. Connect the line supply wire to the L+ terminal.
2. Connect the neutral supply wire to the N(-) terminal.
3. Connect earth ground to the PE GND terminal.

Use a 4 Amp Slo-Blo fuse on the power supply.

HI High-Voltage Power Supply

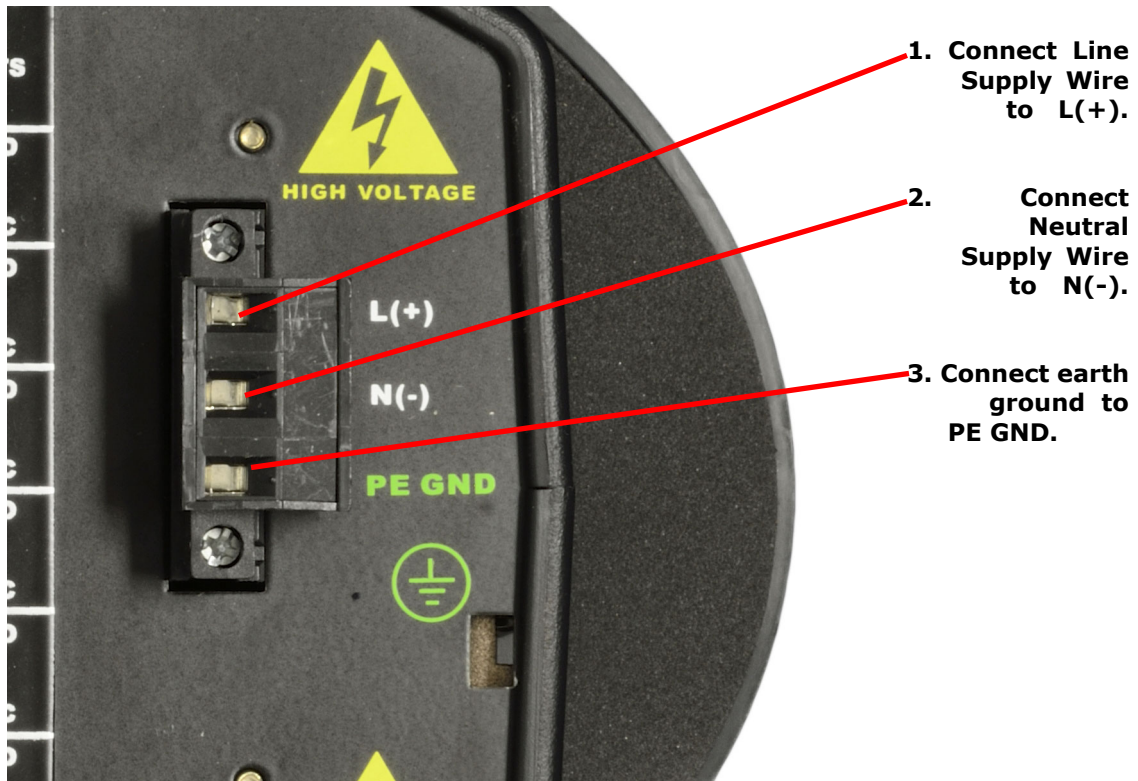

For the HI Option power supply:

4. Connect the line supply wire to the L+ terminal.
5. Connect the neutral supply wire to the N- terminal.
6. Connect earth ground to the PE GND terminal.

Use a 4 Amp Slo-Blo fuse on the power supply.

LD Low-Voltage Power Supply



Note that the wiring for the LD Option power supply has the Positive and Negative terminals REVERSED from the AC and HI models - BE CAREFUL to follow the diagram and instructions shown.

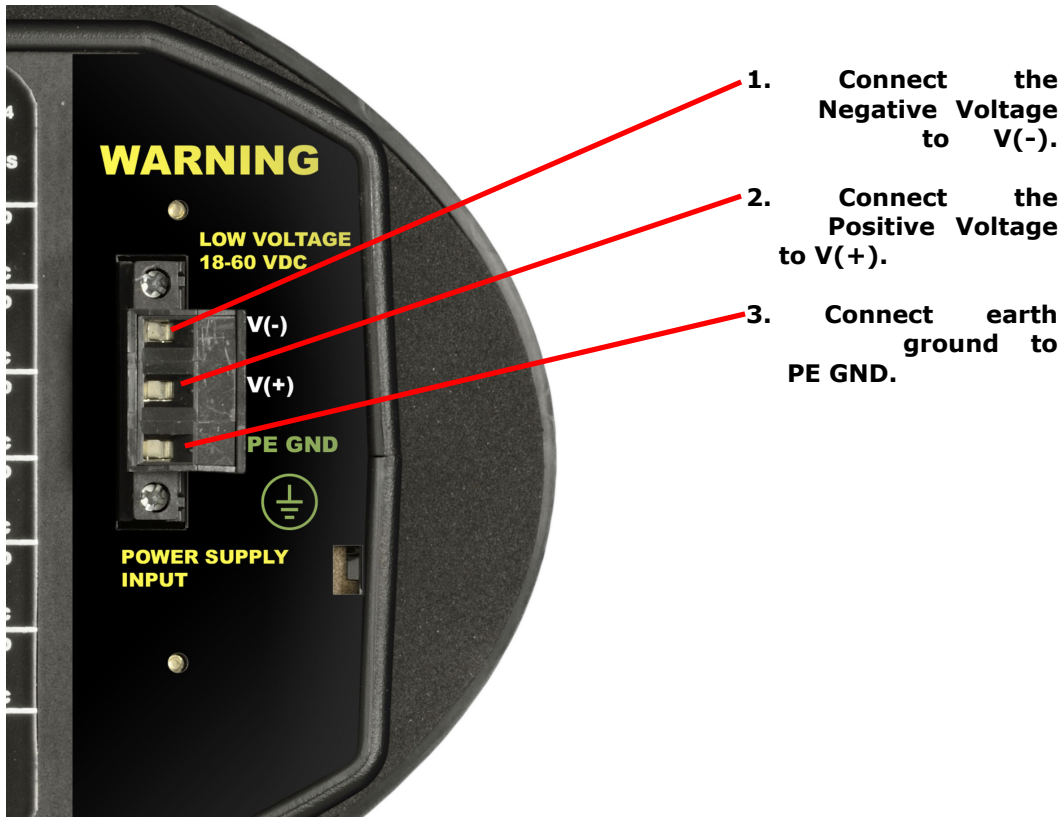

1. Connect the Negative Voltage to V(-).

2. Connect the Positive Voltage to V(+).

3. Connect earth ground to PE GND.

For the LD Option power supply:

1. Connect the negative voltage to the V(-) terminal.
2. Connect the positive voltage to the V(+) terminal.
3. Connect earth ground to the PE GND terminal.

Use a 4 Amp Slo-Blo fuse on the power supply.

4.6 Wiring Diagrams

Choose the diagram that best suits your application. Diagrams appear on the following pages. If the connection diagram you need is not shown, contact GE Grid Solutions for a custom connection diagram.

Service	PTs	CTs	Measurement Method	Figure No.
4W Wye/Delta	0, Direct Connect	3(4*)	3 Element	4.5
4W Wye/Delta	3	3(4*)	3 Element	4.6
4W Wye	2	3	2.5 Element	4.7
4W Wye	0, Direct Connect	3	2.5 Element	4.8
3W Open Delta	2	2	2 Element	4.9
3W Open Delta	0, Direct Connect	2	2 Element	4.10

* With optional CT for current measurement only.

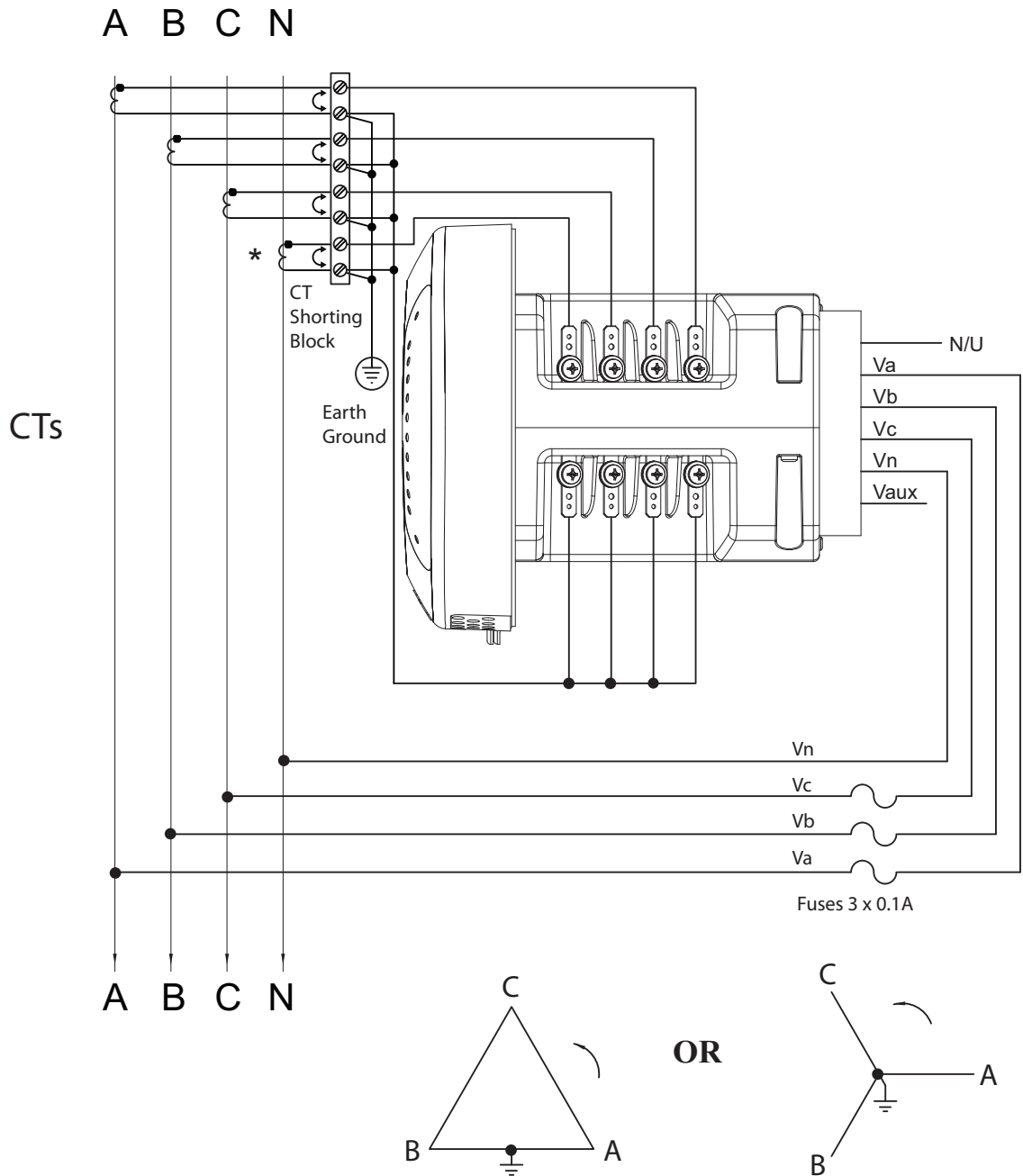

Figure 4-5: 4-Wire Wye or Delta*, 3-Element Direct Connect with 4 CTs**

* See 4.5.2 *Wiring the Monitored Inputs - Vaux*.

** Optional CT for current measurement only.

*** Typically used with Wye system (see 2 Element Delta wiring diagrams)

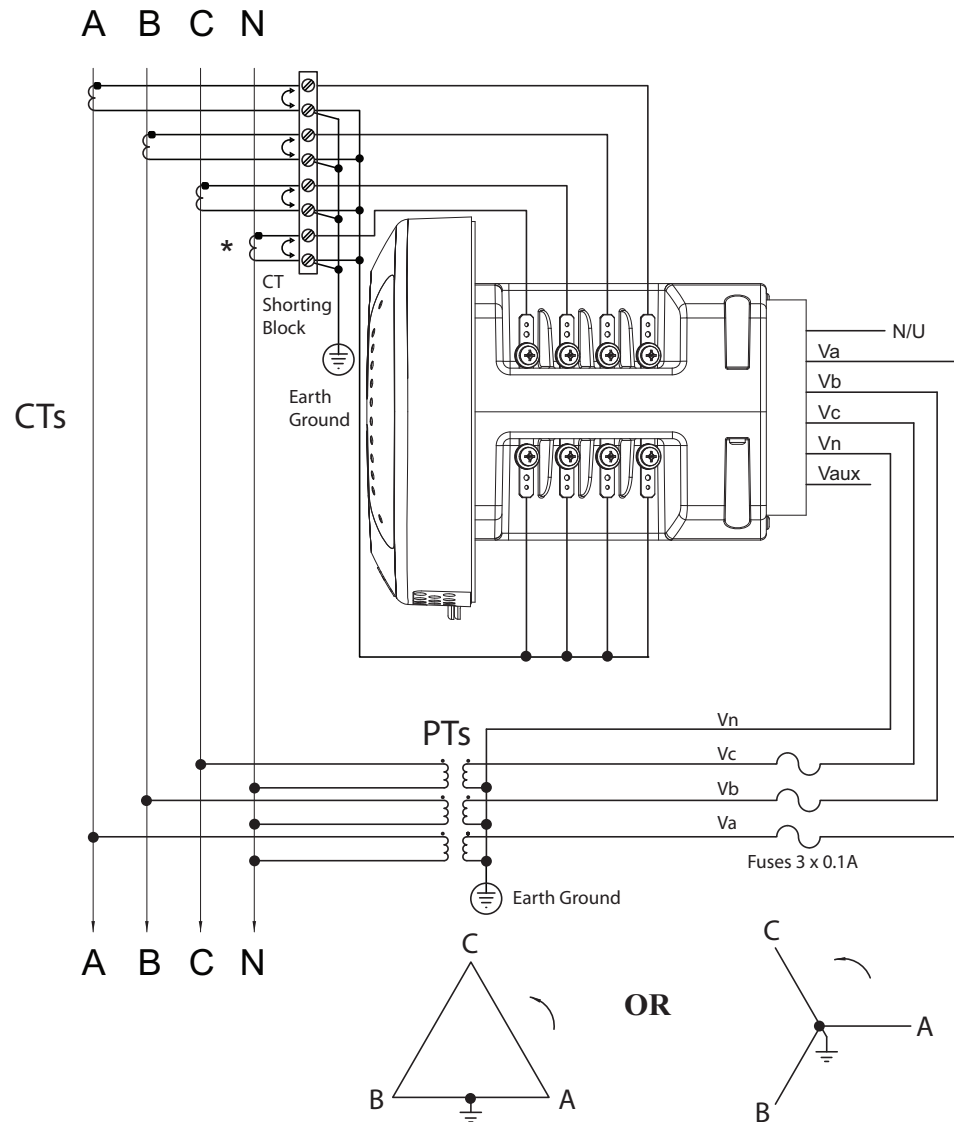

Figure 4-6: 4-Wire Wye or Delta*, 3-Element with 3 PTs and 4 CTs**

* See 4.5.2 *Wiring the Monitored Inputs - Vaux.*

** Optional CT for current measurement only.

*** Typically used with Wye system (see 2 Element Delta wiring diagrams)

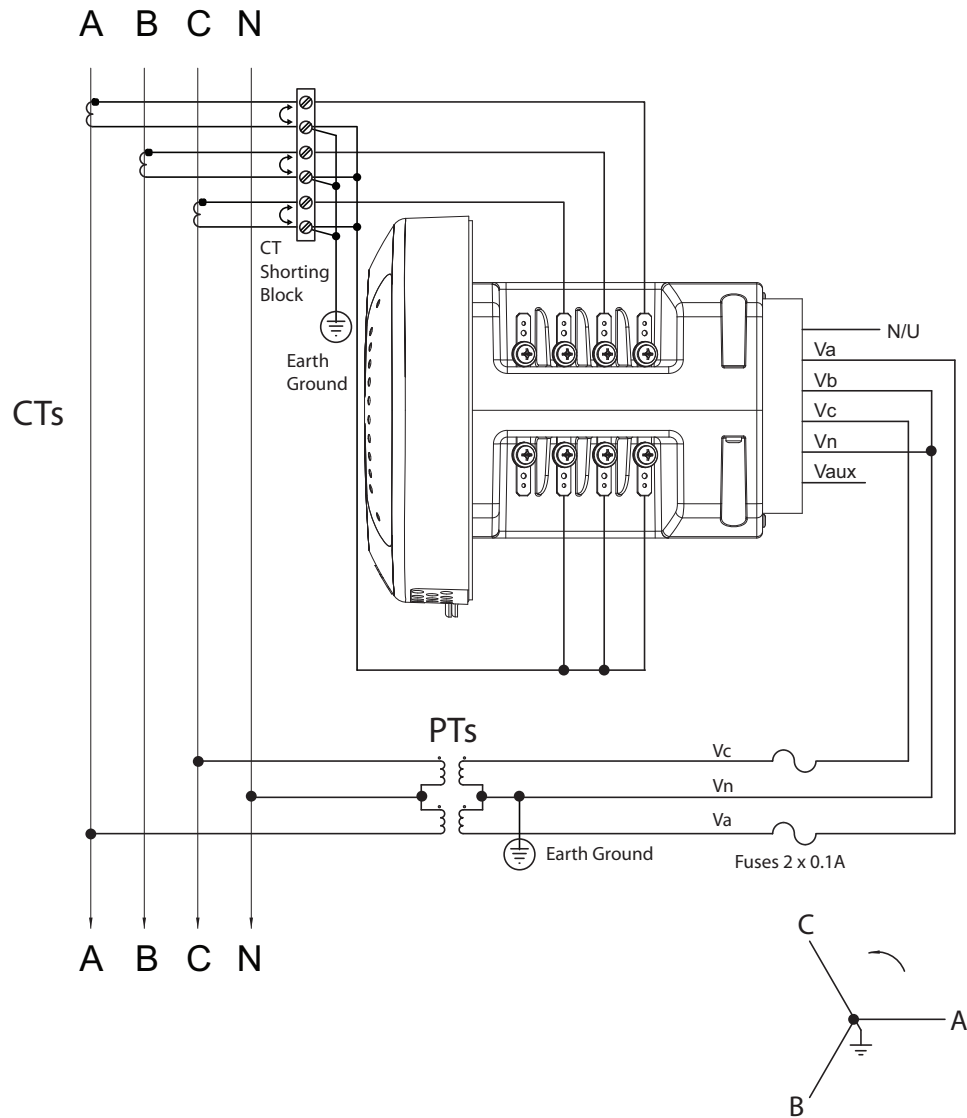

Figure 4-7: 4-Wire Wye, 2.5-Element with 2 PTs and 3 CTs

* See 4.5.2 *Wiring the Monitored Inputs - Vaux.*

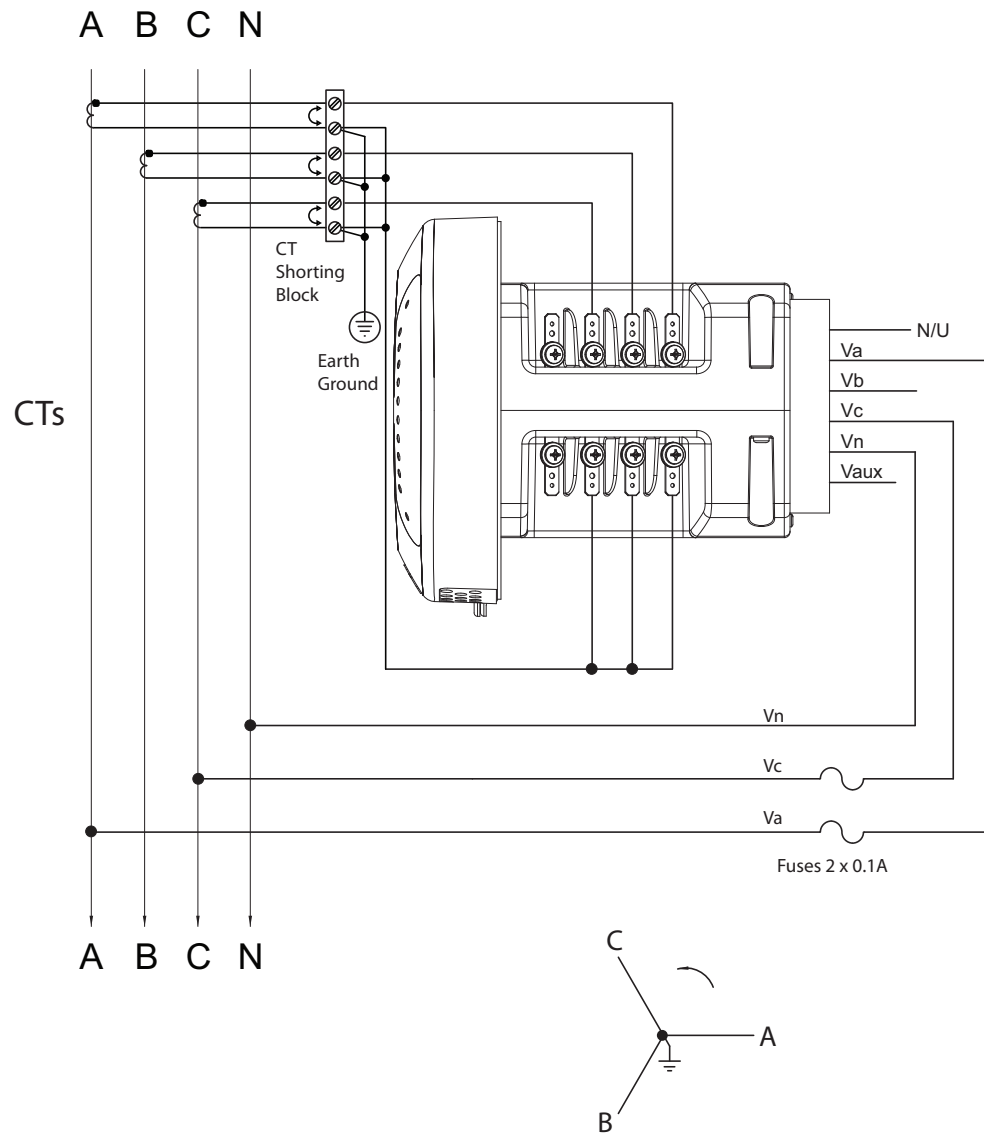

Figure 4-8: 4-Wire Wye, 2.5-Element Direct Connect with 3 CTs

* See 4.5.2 *Wiring the Monitored Inputs - Vaux.*

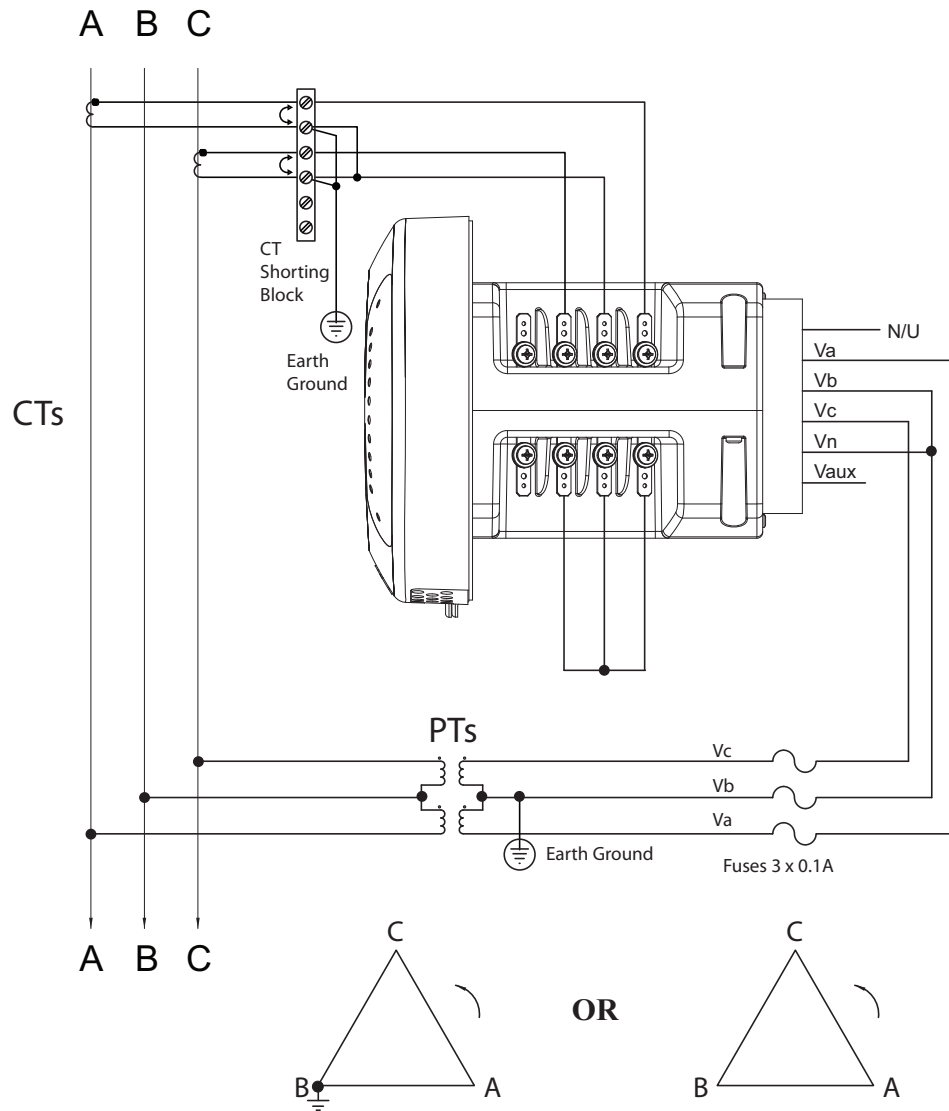

Figure 4-9: 3-Wire, 2-Element Open Delta with 2 PTs and 2 CTs

* See 4.5.2 *Wiring the Monitored Inputs - Vaux.*

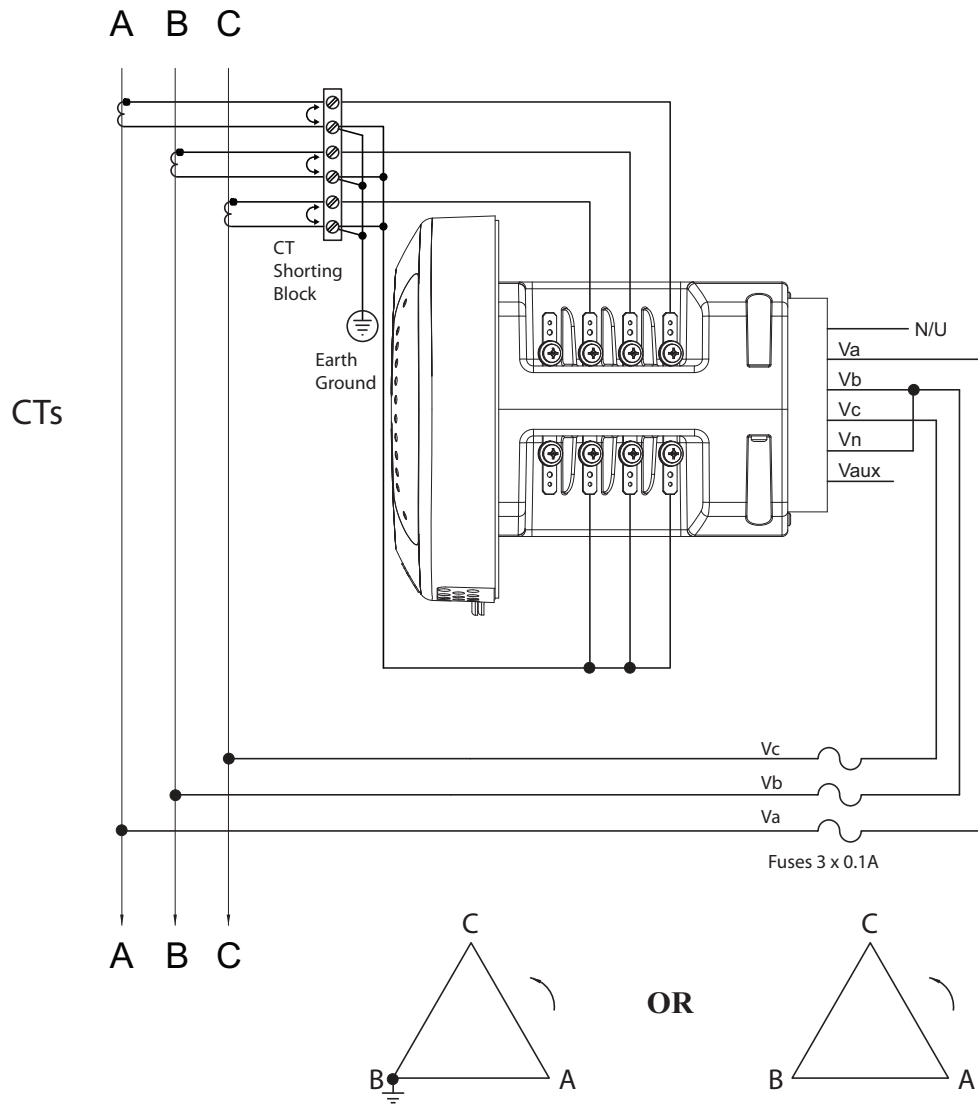

Figure 4-10: 3-Wire, 2-Element Open Delta Direct Voltage with 2 CTs**

* See 4.5.2 *Wiring the Monitored Inputs - Vaux.*

** Typically used for Delta systems.

Multilin™ EPM 9900P

Chapter 5: Communication Wiring

5.1 Communication Overview

The EPM 9900P has many simultaneous paths for sending data to software systems or other electronic instruments. This chapter contains instructions for using the EPM 9900P meter's standard and optional communication capabilities. The EPM 9900P meter offers the following communication modes:

- RJ45 100BaseT Ethernet connection (standard)
- ANSI Optical port (standard)
- USB 2.0 connection (standard)
- Two RS485 communication ports (optional)
- Second Ethernet connection - either RJ45 or Fiber Optic (optional)

NOTICE

Software and manuals for the EPM 9900p meter can be found on the GE VERNOVA website at:

<https://www.gevernova.com/grid-solutions/automation/protection-control-metering/metering/epm-9900p>

5.2 RJ45 and Fiber Ethernet Connections

The standard RJ45 connection allows an EPM 9900P meter to communicate with multiple PCs simultaneously. The RJ45 jack is located on the back of the meter. The EPM 9900P meter's Ethernet port conforms to the IEEE 802.3, 10BaseT and 100BaseT specifications using unshielded twisted pair (UTP) wiring. GE recommends CAT5 for cabling. For details on this connection, see Chapter 9 *EPM 9900P Network Communications*.

The optional second Ethernet connection for the EPM 9900P meter consists of either an RJ45 (E1) or a Fiber Optic (E2) Communication card. See Chapter 11 *Using the I/O Options* for details.

5.3 ANSI Optical Port

The Optical port lets the EPM 9900P meter communicate with one other device, e.g., a PC. Located on the left side of the meter's face, it provides communication with the meter through an ANSI C12.13 Type II Magnetic Optical Communications Coupler (not included). You can then program the meter through the Optical port using GE Communicator software.



The EPM 9900P optical port offers the standard inverted mode for communication, but can also be programmed in non-inverted mode using the GE Communicator software. Refer to the *GE Communicator Instruction Guide* for instructions.

5.4 USB Connection

The USB connection allows the EPM 9900P meter to communicate with a computer that has a USB 1.1 or USB 2.0 Host port. The meter's USB port is configured to operate as a virtual serial communication channel that the PC sees as a simple COM port with a baud rate of up to 115200.

The USB virtual serial communication channel:

- Supports legacy applications that were designed to only work with a serial communication channel
- Is compatible with standard USB cables that terminate with a USB Type B plug
- The maximum length of the USB cable is 5 meters. Greater lengths require hubs or active extension cables (active repeaters).



Figure 5-1: USB Type B Plug

If you are using a PC with Windows® 7 OS, connect the USB cable from your PC to the meter's USB port on the front panel. The system will install a driver for you. For earlier operating systems, GE provides a driver for the EPM 9900P meter. The driver configures the computer's USB Host port as a virtual serial port compatible with the EPM 9900P meter's USB device port. See Appendix A *Installing the USB Virtual Comm Port* for instructions on installing the driver.

5.5 RS485 Connections

The optional RS485 connections allow multiple EPM 9900P meters to communicate with another device at a local or remote site. All RS485 links are viable for a distance of up to 4000 feet (1219 meters). RS485 ports 1 and 2 on the EPM 9900P meter are optional two-wire, RS485 connections with a baud rate of up to 115200.

Figure 5.3 shows the detail of a 2-wire RS485 connection.



Figure 5-2: 2-wire RS485 Connection

NOTES on RS485 Communication:

- Use a shielded twisted pair cable 22 AWG (0.33 mm²) or thicker, and ground the shield, preferably at one location only.
- Establish point-to-point configurations for each device on a RS485 bus: connect (+) terminals to (+) terminals; connect (-) terminals to (-) terminals.
- Connect up to 31 meters on a single bus using RS485. Before assembling the bus, each meter must have a unique address: refer to the *GE Communicator Instruction Manual* for instructions.
- Protect cables from sources of electrical noise.
- Avoid both "Star" and "Tee" connections (see Figure 5-4).
- Connect no more than two cables at any one point on an RS485 network, whether the connections are for devices, converters, or terminal strips.
- Include all segments when calculating the total cable length of a network. If you are not using an RS485 repeater, the maximum length for cable connecting all devices is 4000 feet (1219 meters).
- Connect shield to RS485 Master and individual devices as shown in Figure 5-2. You may also connect the shield to earth-ground at one point.

NOTICE

Termination Resistors (RT) may be needed on both ends for longer length transmission lines. However, since the meter has some level of termination internally, Termination Resistors may not be needed. When they are used, the value of the Termination Resistors is determined by the electrical parameters of the cable.

Figure 5-3 shows a representation of an RS485 Daisy Chain connection.

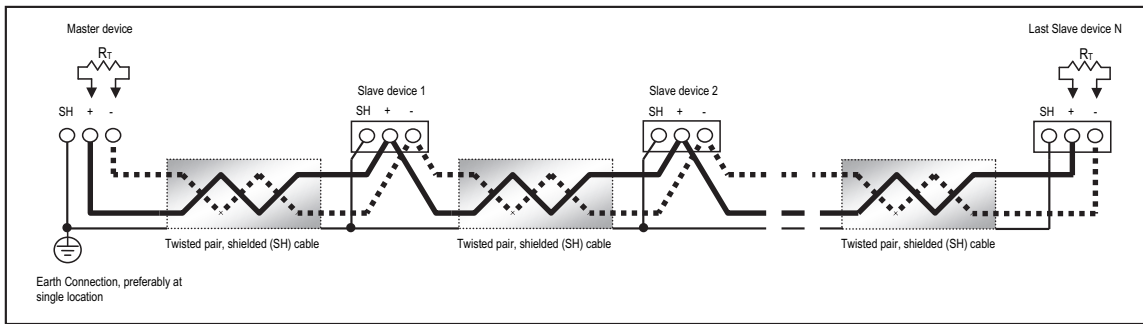

Figure 5-3: RS485 Daisy Chain Connection

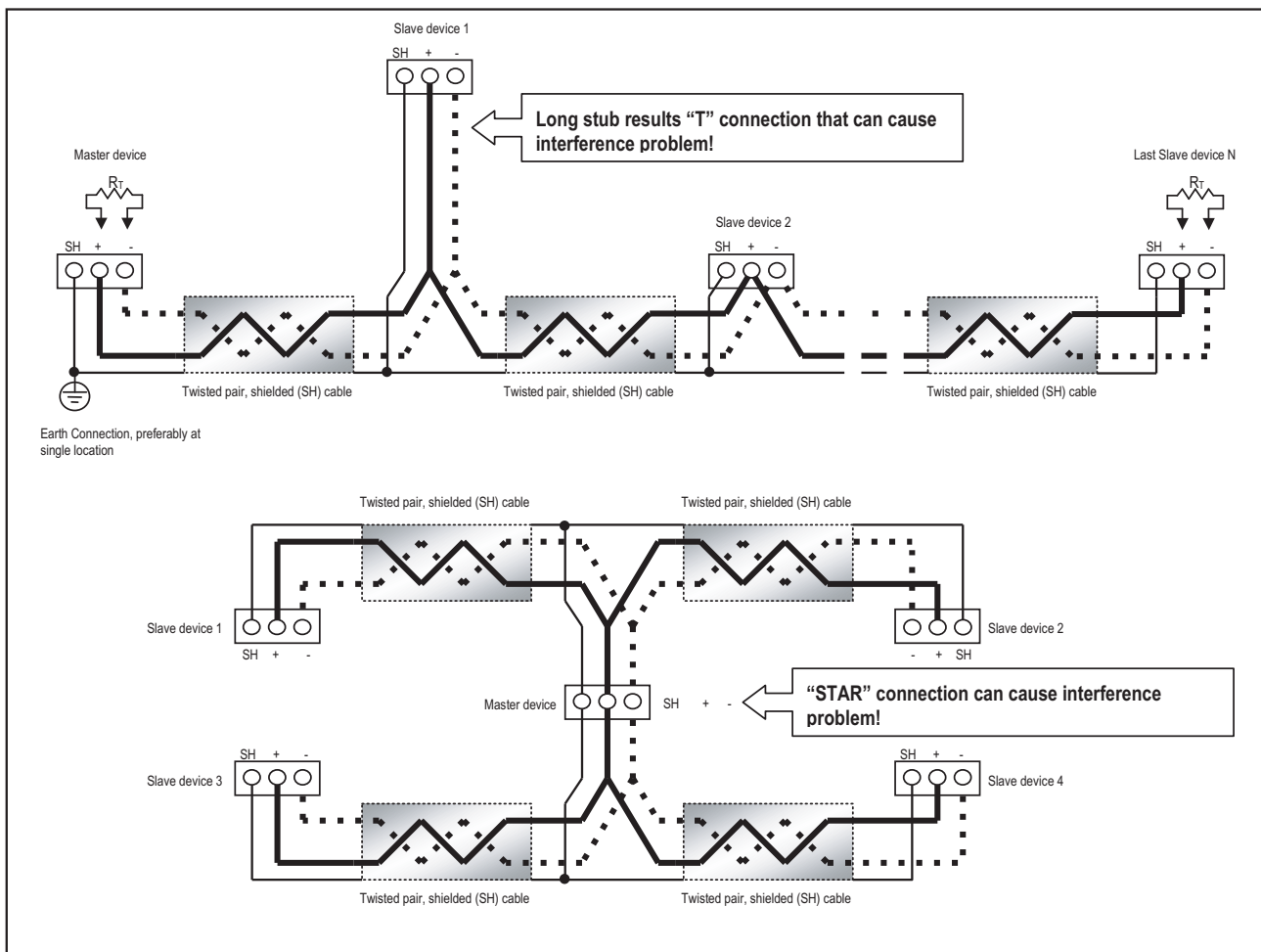

Figure 5-4: Incorrect "T" and "Star" Topologies

5.6 Remote Communication with RS485

Use either optional RS485 port on the EPM 9900P meter. The link using RS485 is viable for up to 4000 feet (1219 meters).

Use GE Communicator software to set the port's baud rate to 9600 and enable Modbus ASCII protocol. See the *GE Communicator Instruction Manual* for instructions. Remember, Modbus RTU **will not** function properly with Modem communication. You must change the protocol to Modbus ASCII.

You must use an RS485 to RS232 converter and a Null modem.

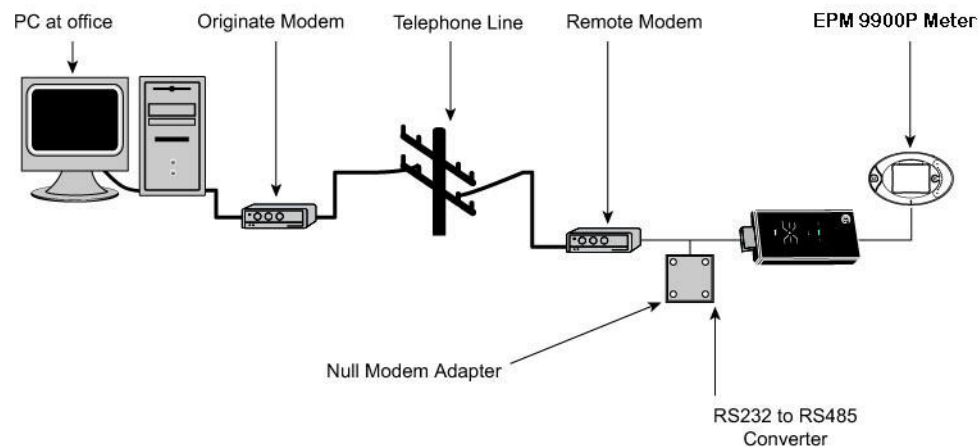

Figure 5-5: Remote Communication

5.7 Programming Modems for Remote Communication

You must program a modem before it can communicate properly with most RS485 or RS232-based devices. This task is often quite complicated because modems can be unpredictable when communicating with remote devices.

Set the following strings to communicate with the remote EPM 9900P meter(s). Consult your modem User manual for the proper string settings or see Section 5.8 for a list of selected modem strings.

Modem Connected to a Computer (the Originate Modem)

- Restore modem to factory settings. This erases all previously programmed settings.
- Set modem to display Result Codes. The computer will use the result codes.
- Set modem to Verbal Result Codes. The computer will use the verbal result codes.
- Set modem to use DTR Signal. This is necessary for the computer to insure connection with the originate modem.

- Set modem to enable Flow Control. This is necessary to communicate with remote modem connected to the EPM 9900P meter.
- Instruct modem to write the new settings to activate profile. This places these settings into nonvolatile memory; the setting will take effect after the modem powers up.

Modem Connected to the EPM 9900P Meter (the Remote Modem)

- Restore modem to factory settings. This erases all previously programmed settings.
- Set modem to auto answer on n rings. This sets the remote modem to answer the call after *n* rings.
- Set modem to ignore DTR Signal. This is necessary for the EPM 9900P meter, to insure connection with originate modem.
- Set modem to disable Flow Control. The EPM 9900P meter’s RS232 communication does not support this feature.
- Instruct modem to write the new settings to activate profile. This places these settings into nonvolatile memory; the setting will take effect after the modem powers up.
- When programming the remote modem with a terminal program, make sure the baud rate of the terminal program matches the EPM 9900P meter’s baud rate.

5.8 Selected Modem Strings

Modem	String/Setting
Cardinal modem	AT&FE0F8&K0N0S37=9
Zoom/Faxmodem VFX V.32BIS(14.4K)	AT&F0&K0S0=1&W0&Y0
Zoom/Faxmodem 56Kx Dual Mode	AT&F0&K0&C0S0=1&W0&Y0
USRobotics Sportster 33.6 Faxmodem: DIP switch setting	AT&F0&N6&W0Y0 (for 9600 baud) Up Up Down Down Up Up Up Down
USRobotics Sportster 56K Faxmodem: DIP switch setting	AT&F0&W0Y0 Up Up Down Down Up Up Up Down

5.9 High Speed Inputs Connection

The EPM 9900P meter's built-in High Speed Inputs can be used in two ways:

- Attaching status contacts from relays, breakers or other devices for status or waveform initiation
- Attaching the KYZ pulse outputs from other meters for pulse counting and totalizing

Even though these inputs are capable of being used as high speed digital fault recording inputs, they serve a dual purpose as KYZ counters and totalizers. The function in use is programmable in the meter and is configured via GE Communicator. Refer to the *GE Communicator Instruction Manual* for instructions on programming these features.

The High Speed Inputs can be used with either dry or wet field contacts. For wet contacts, the common rides on a unit-generated Nominal 15 VDC. No user programming is necessary to use either wet or dry field contacts.

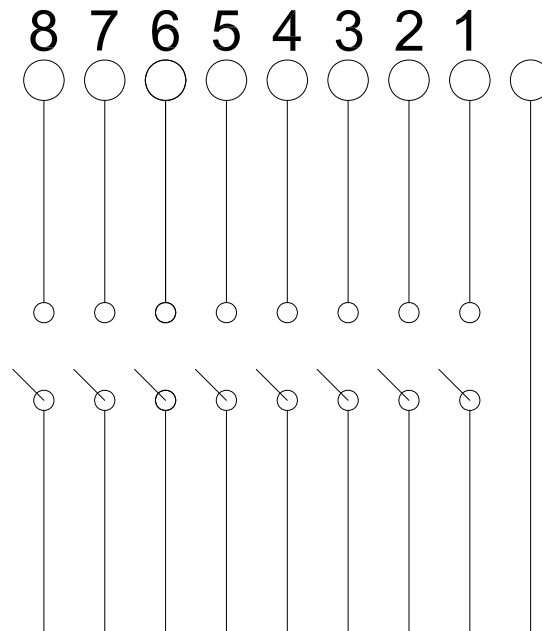

Figure 5-6: High-Speed Inputs Connection

5.10 IRIG-B Connections

IRIG-B is a standard time code format that synchronizes event time-stamping to within 1 millisecond. An IRIG-B signal-generating device connected to the GPS satellite system synchronizes EPM 9900P meters located at different geographic locations. EPM 9900P meters use an un-modulated signal from a satellite-controlled clock (such as the GE MultiSync 100). For details on installation, refer to the User manual for the satellite-controlled clock in use. Below are installation steps and tips to help you.

Connection:

Connect the (+) terminal of the EPM 9900P meter to the (+) terminal of the signal generating device; connect the (-) terminal of the EPM 9900P meter to the (-) terminal of the signal generating device.

Installation:

Set Time Settings for the meter being installed.

1. From the GE Communicator Device Profile menu:
 - i Click **General Settings > Time Settings > one of the Time Settings lines** to open the Time Settings screen.
 - ii Set the Time Zone and Daylight Savings (Select **AutoDST** or **Enable** and set dates).
 - iii Click **Update Device Profile** to save the new settings.

(See the *GE Communicator Instruction Manual* for details.)

2. Before connection, check that the date on the meter clock is correct (or, within 2 Months of the actual date). This provides the right year for the clock (GPS does not supply the year).
3. Connect the (+) terminal of the EPM 9900P meter to the (+) terminal of the signal generating device; connect the (-) terminal of the EPM 9900P meter to the (-) terminal of the signal generating device.

Troubleshooting Tip: The most common source of problems is a reversal of the two wires. If you have a problem, try reversing the wires.

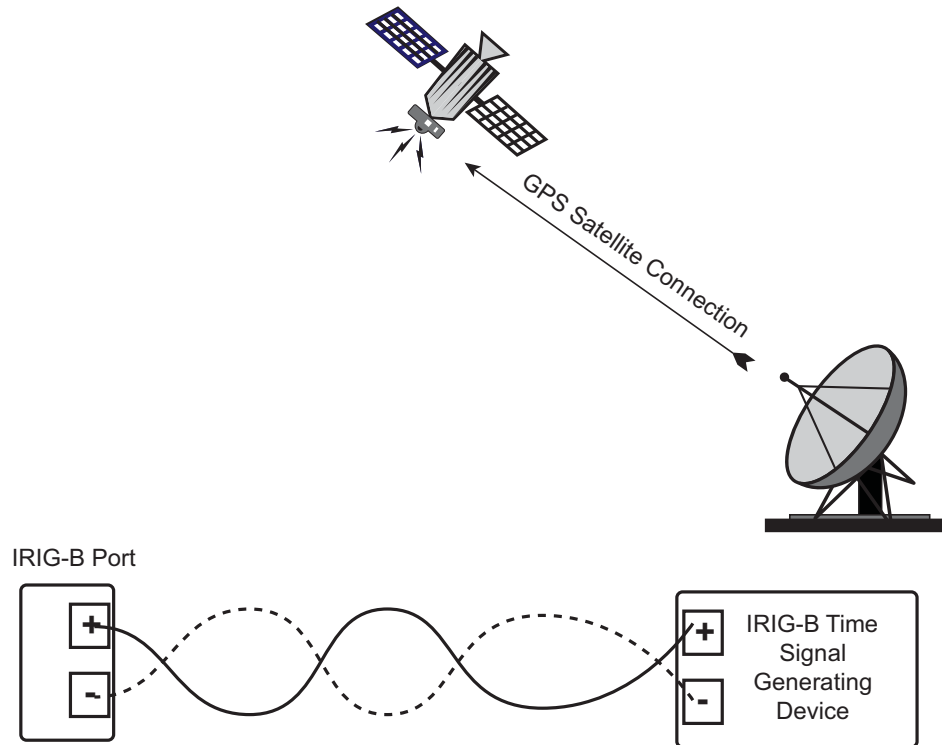

Figure 5-1: IRIG-B Communication

NOTICE

Please make sure that the selected clock can drive the amount of wired loads.

5.11 Time Synchronization Alternatives

(See the *GE Communicator Instruction Manual* for details.)

IRIG-B (see section 5.10)

- IRIG-B (inter-range instrumentation group) time codes are clock signals received from a precision timing GPS receiver.
- All EPM 9900P meters are equipped to use IRIG-B for time synchronization.
- If IRIG-B is connected, this form of time synchronization takes precedence over the internal clock. If the GPS Signal is lost, the internal clock takes over time keeping at the precise moment the signal is lost.
- IRIG-B is one of the two methods that can be used with synchrophasors for time synchronization.

Line Frequency Clock Synchronization

- Line Frequency Sync (synchronization) allows the meter to use the AC line frequency as a time base to keep its internal clock accurate. It should be used as the default when better time synchronization is not available.
- All EPM 9900P meters are equipped with Line Frequency Clock Synchronization, which may be enabled or disabled for use instead of IRIG-B. If Line Frequency Clock Synchronization is enabled and power is lost, the internal clock takes over at the precise moment power is lost.

Internal Clock Crystal

- The EPM 9900P meter is equipped with an internal clock crystal that is accurate to 3.5 ppm, or less than 10 seconds per month drift, and which can be used if IRIG-B is not connected and/or Line Frequency Clock Synchronization is not enabled.
- The meter has a battery backup that is used for the real time clock only, in case of a power outage. The battery is a Panasonic BR3032, rated at 500 mAh and with a battery life of at least ten years. A Low Batt message is displayed on the status bar of the GE Communicator software Main screen (see the *GE Communicator Instruction Manual* for details) when the battery is equal to or less than 2.55 volts, which is still well within the operating range of the clock component. It is recommended that you change the battery within three months after the Low Batt message appears. Contact GE Grid Solutions customer service and support for battery replacement instructions.

SNTP (Simple Network Time Protocol)

- With SNTP, the meter accesses a Network Time Protocol (NTP) Server for time synchronization. The NTP server can be either a device with a real-time clock that is networked with your meter, or an NTP server on the Internet. You can configure SNTP time synchronization for either the standard or the optional Ethernet card. SNTP configuration is done in the Device Profile. Refer to the *GE Communicator Instruction Manual* for instructions.

DNP Time Synchronization

- Using GE Communicator, you can set the meter to request time synchronization from the DNP Master. Requests can be made from once per minute to once per day.

IEEE 1588 PTPv2 (Precision Time Protocol)

- The time synchronization provided by optional IEEE 1588 PTPv2 architecture lets you synchronize time for a network without needing a GPS receiver for each node. The IEEE 1588 standard uses a “Best Master Clock” algorithm, which identifies the clock with the most accurate time and then synchronizes all the other devices on the network with it, to maintain accurate time throughout the network of devices. This time synchronization method achieves accuracy within the sub-microsecond range. When set up as the meter’s time synchronization source, the meter’s Network card 2 operates as a slave device which gets its time synchronization from a PTP Master. GE Communicator software is used to setup IEEE 1588 PTPv2 as the meter’s time synchronization source. Refer to the *GE Communicator Instruction Manual* for more details.

- IEEE 1588 PTPv2 is one of the two methods that can be used with synchrophasors for time synchronization.

Other Time Setting Tools

- **Tools > Set Device Time:** for manual or PC Time Setting
- **Script & Scheduler:** time Stamps Retrieved Logs and Data
- **MV90:** can synchronize time on retrievals in the form of a time stamp; refer to the *GE Communicator Instruction Manual* (HHF Converter) for MV-90 details.

Multilin™ EPM 9900P

Chapter 6: Using the EPM 9900P Meter's Touch Screen Display

6.1 Introduction

The EPM 9900P meter's display is a QVGA (320 x 240 pixel) LCD color display with touch screen capability. The display screens are divided into two groups:

- Fixed System screens - used for system data and diagnostics
- Dynamic screens - used for viewing electrical information

6.2 Fixed System Screens

There are 12 Fixed System screen options: Device Information, Communication Settings, Board Settings, Device Status, System Message, Touch Screen Calibration, CF S.M.A.R.T. Tool, IEC-61850, Task Info, CPU Stats, SNTP, and Test Mode (the Test Mode button is hidden until activated; see chapter 12). In addition, there is a Back option, which brings you to the first Dynamic screen. To view a screen, touch the screen name on the display

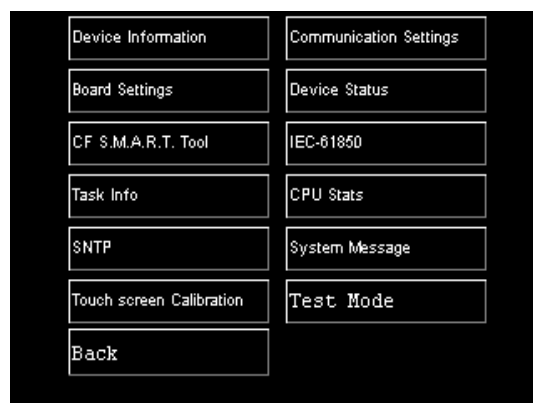

- You will only see the System Message option if there are messages for you to view. See the page 6-5 for additional information on the System Message screen.
- If you want to calibrate the touch screen, perform the following actions:

1. Press and hold the **Backlight** button on the right front panel of the meter for about 2 seconds.
2. Press the "i" button at the top of the Dynamic screen within ten seconds of pressing the **Backlight** button.
3. You will see the Fixed System screens menu shown above. Press "Touch Screen Calibration". See the instructions for using the Touch Screen Calibration screen on page 6-5.

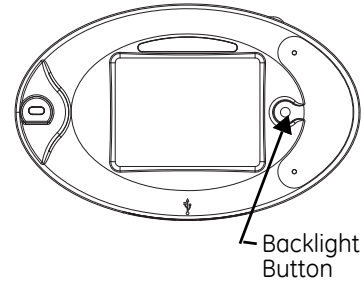

Device Information:

See the example screen below. The **Back** button returns you to the initial Fixed System screen.

This screen displays the following information about the EPM 9900P meter:

- Device type
- Device name
- Serial number
- COMM boot version
- COMM runtime version
- DSP runtime version
- FPGA version
- Touch screen version
- CF (Compact Flash) model
- CF (Compact Flash) serial number
- CF (Compact Flash) FAT type
- CF (Compact Flash) size
- Software Option level enabled currently
- Sealing switch status
- Security (Password) status
- Current range (The current range class of the meter)

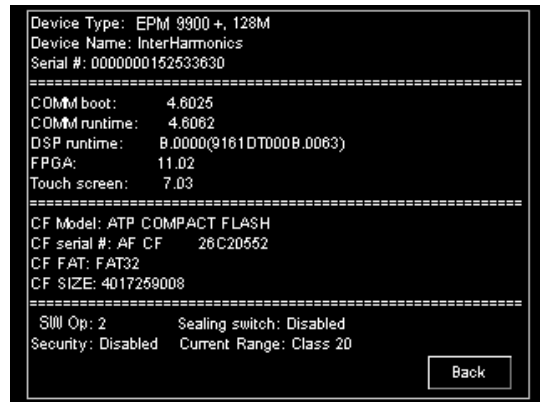

Communication Settings:

This screen displays the following Communication port information:

- RS485 Port 1 settings
- RS485 Port 2 settings
- USB port settings
- Optical port settings
- Ethernet Port 1 settings
- Ethernet Port 2 settings

See the example screen on the right. The **Back** button returns you to the initial Fixed System screen.

```

PORT:      Addr, Baud rate, Data, Parity, Stop, Protocol, [Mode]
=====
RS485-1 :  Not Installed
RS485-2:  Not Installed
USB:      1, 115200, 8, NONE, 1, Modbus RTU
OPTICAL:  1, 57600, 8, NONE, 1, Modbus RTU, Non-Inverted
=====
ETHERNET 1:
IP:       172.20.166.230
MASK:     255.255.248.0
GATEWAY:  172.20.161.23
MAC:      00-01-58-00-C2-0C
Web@60, FTP@21, MBTCP@502
ETHERNET 2: Not Installed
IP:
MASK:
GATEWAY:
MAC:
Web@0, FTP@0, MBTCP@0
Back
  
```

Board Settings:

This screen displays the following information:

- Analogue board settings
- Ethernet 1 board settings
- Digital board settings
- Front panel settings
- Option card Slot 1 settings
- Option card Slot 2 settings
- Option card Slot 3 settings
- Option card Slot 4 settings

See the example screen on the right. The **Back** button returns you to the initial Fixed System screen.

```

Board:      Serial #, Status, [Board type]
=====
Analogue board: EA0006, Recg. (test passed)
Ethernet 1:   EA00063, Recg. (test passed)
Digital board: 123456789000, Recg. (test passed)
Front panel:  EA00008, Recg. (test passed)
Slot 1:       EA0031, Recg. (test passed), RS485-2/Pulse Out-4
Slot 2:       EA0005, Recg. (test passed), Ether2/TP
Slot 3:       A00001, Recg. (test passed), Relay Out
Slot 4:       No board
Back
  
```

Device Status:

This screen displays the following information:

- COMM runtime state
- DSP state
- Meter "On Time"
- Ethernet port link state

See the example screen on the right. The **Back** button returns you to the initial Fixed System screen.

```

Type:      Status (#)
=====
COMM STATE: Healthy
DSP STATE: Healthy
=====
On Time: 07-02-2015 10:42:21
=====
ETHERNET 1 Link State: Link is up.
ETHERNET 2 Link State: N/A
Back
  
```

System Message:

This screen displays any system messages. The bottom of the screen will show **Prev Page** and **Next Page** buttons only if there is more than one page of messages. See the example screen below.

The **Back** button returns you to the initial Fixed System screen.

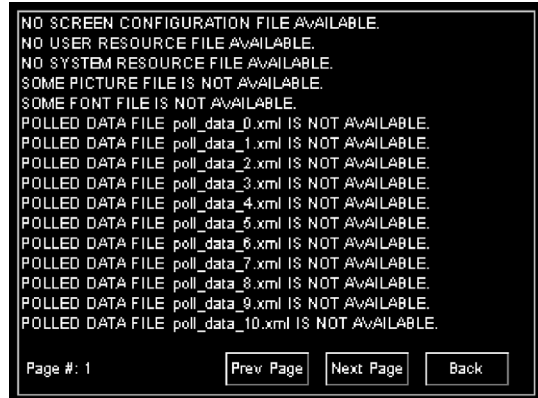

The System Message option only appears in the Fixed System screens menu if there are messages to display.

Touch Screen Calibration:

This screen is used to calibrate the touch screen display. When you select this option, a series of four messages directs you in performing screen calibration. Each message tells you to touch a corner of the screen where a small crosshair is located. Touching the crosshair calibrates the display. Use a pointed tool to touch the calibration crosshairs.

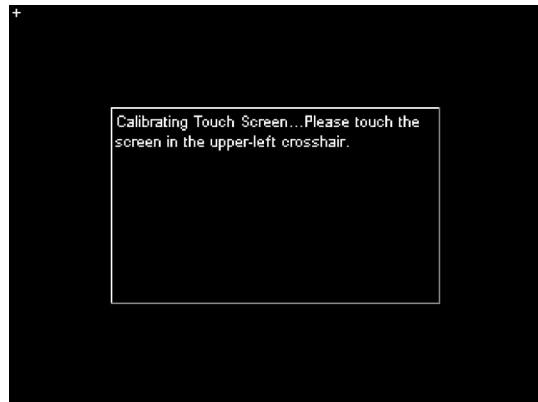

See the example screen on the right, showing the first of the four messages.

When all four calibrations have been performed, a Calibrating Test screen is shown.

Three crosshairs indicate places to touch. After each touch a red crosshair is shown to verify the calibration. If the calibration is correct, press the **Accept** button; otherwise press the **Reject** button, which causes the calibration process to start again. See the example screen below.



See page 6-1 for instructions on accessing Touch Screen Calibration.

CF S.M.A.R.T. Tool

The EPM 9900P meter uses an Industrial grade, specialized compact flash disk drive. This drive has many features not found in commercial flash. One of these features is the S.M.A.R.T. tool. This tool provides user accessed diagnostics on the health of the drive.

This screen displays compact flash S.M.A.R.T. (Self-Monitoring, Analysis, and Reporting

Technology) information. The S.M.A.R.T. must be supported and enabled to contain valid data. The screen displays the following information:

- Compact flash model number
- Compact flash serial number
- Compact flash size in bytes
- Type of compact flash (Regular/S.M.A.R.T.)
- Status of S.M.A.R.T. feature (Supported/Not Supported, Enabled/Disabled)
- Status of S.M.A.R.T. data (Valid/Invalid)
- S.M.A.R.T. Revision code
- S.M.A.R.T. Firmware version and date code
- S.M.A.R.T. number of Initial Invalid blocks, number of bad Run Time blocks, number of Spare blocks (decimal)
- S.M.A.R.T. number of child pairs (decimal)
- Compact flash type (SLC/MLC)
- Compact flash specification's maximum erase count (100000 if flash is SLC; 5000 if flash is MLC)
- Compact flash's average erase count
- Compact flash remaining % of life (100 - "Average erase count"*100/"Flash spec max erase count")

This diagnostic information lets the user know when the drive may wear out and need to be replaced or the meter be de-commissioned.

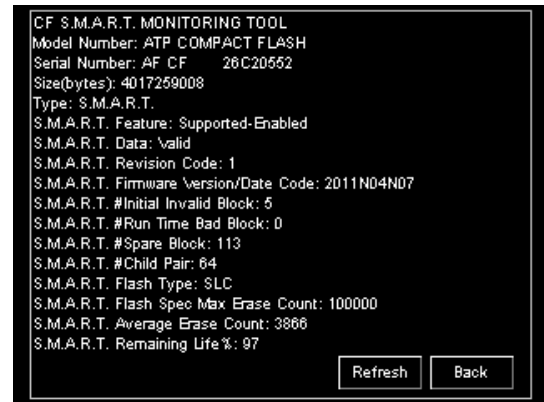

IEC-61850

The IEC-61850 screen contains information about the IEC-61850 Protocol Ethernet Network server, including any system or error messages. It displays:

- Server state
- Server Initialization time in seconds
- Memory statistics
- SCL parsing messages
- Stack indications
- Stack messages

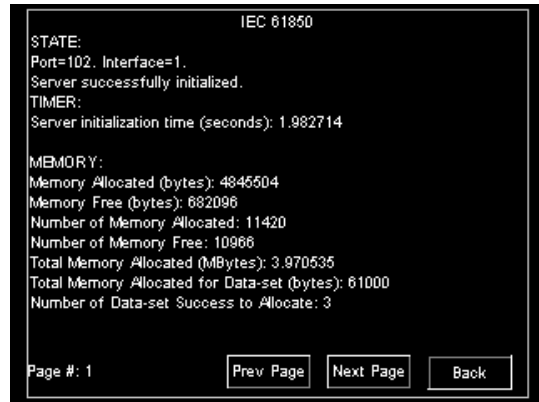

Task Info

The Task Info screen contains information about free stack size based on the tasks in the processing stack. This information is only useful for troubleshooting or de-bugging purposes.

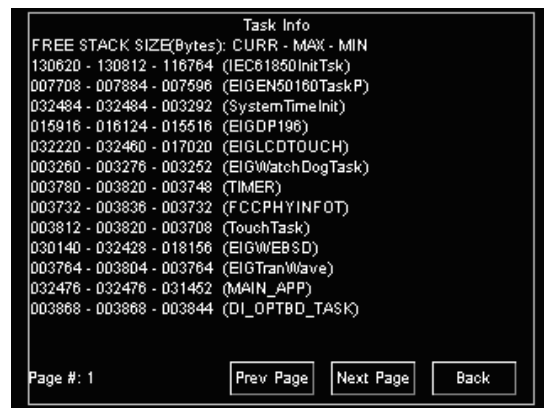

CPU Stats

The CPU Stats screen contains information about the processor's state and how close it is to executing the Idle task.

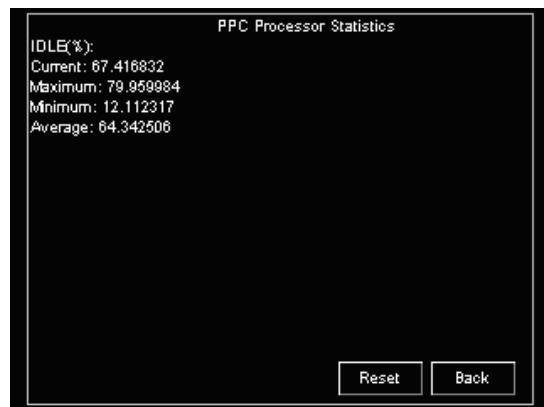

SNTP

The SNTP screen contains information about the meter's SNTP (Simple Network Time Protocol) settings:

- State (enabled or disabled)
- Mode
- UDP port number
- Clock sync source
- Sync process timeout in seconds
- Sync rate in minutes
- SNTP server(s) IP address
- Server errors
- Current server
- Sync Countdown
- Server Refresh Countdown

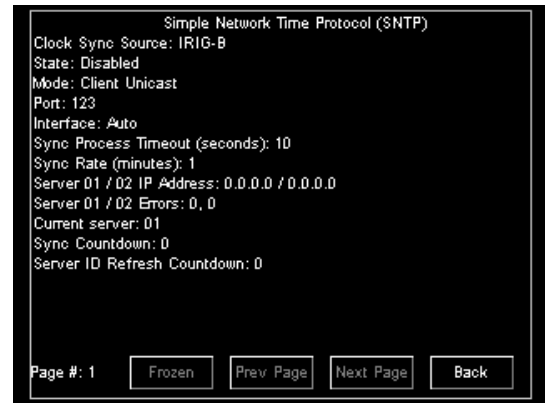

See the GE *Communicator Instruction Manual* for details on setting SNTP through the meter Device Profile.

SNMP

The SNMP screen shows the state and settings for the meter's Simple Network Management Protocol (SNMP) implementation. It displays:

- Agent Community Name
- Traps Community Name
- Node Name
- Node Location
- Node Contact
- Agent State
- Traps State
- Traps 01 - 08 IP addresses
- Trap events

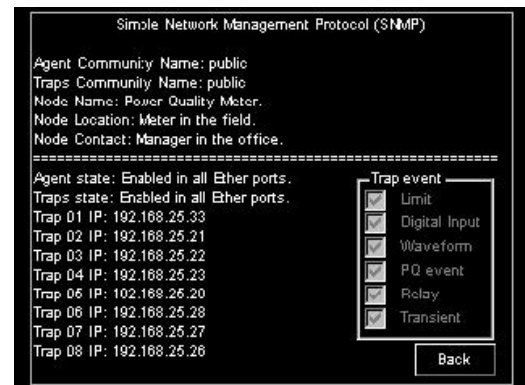

See Appendix D for details on the meter's SNMP application.

Test Mode

See Chapter 12 for instructions on using Test Mode.

Security

When password protection and the sealing switch are enabled, you can display the Security screens in this way: while on one of the Dynamic screens, press and hold the **Backlight** button for two seconds and then press the “i” button while still pressing the **Backlight** button. You will see the main Fixed System screen and the **Security** button will be shown. Press the **Security** button to open the Security screen.

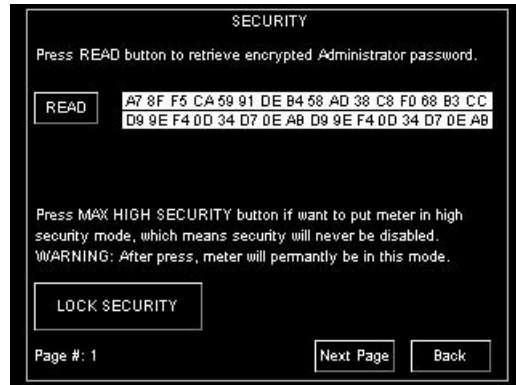

- The **Read** button can only be pressed if the sealing switch has been activated, and it will remain active until the sealing switch times out. This button can be used if the Admin password is lost. When pressed, this button retrieves the Admin password, encrypted using the TEA algorithm.
- The **Lock Security** button can only be pressed if the sealing switch is enabled. After pressing this button, a new screen with a keyboard is displayed, asking for the Admin username (Admin) and password. As soon as these are entered correctly, **the security is locked and cannot be disabled.**



Ensure that security needs to be locked **before** entering the Admin password. **There is no way to disable security once it is locked.**

- The **Back** button returns you to the main Fixed System screen.
- The **Next Pag** button will be shown only when the meter is in Resilient Cyber Security mode. When pressed, the Security - Pw/Key Lockout & Expiration Info screen is displayed (see the following section).

Security - PW/Key Lockout & Expiration Info

This screen displays Resilient Cyber Security’s expiration and lockout information.

- Under account, the ten user IDs and the Admin are listed.
- PW lockout shows the amount of time, in hours and/or minutes, that a user’s password is locked out - i.e., the user can’t sign on. Password lockout occurs when there are failed attempts at logging on. After three failed attempts, the user is locked out for one minute. After each subsequent set of three failed attempts, the lockout time is doubled; the maximum lockout time is 24 hours. The lockout time is reset after a successful entry.

Account	Pw Lockout	Key Lockout	Expiration
User1	1 minute	Not Locked	Expired!
User2	59 minutes	Not Locked	1 minute
User3	1:00 hour	Not Locked	59 minutes
User4	1:59 hour	Not Locked	1:00 hour
User5	2:00 hours	Not Locked	1:59 hour
User6	23:59 hours	1 minute	2:00 hours
User7	24:00 hours	2 minutes	47:59 hours
User8	Not Locked	3 minutes	2 days
User9	Not Locked	4 minutes	N.A.
User10	Not Locked	5 minutes	N.A.
Administrator	Not Locked	Not Locked	359 days

- Expiration shows the amount of time a user is locked out due to repeated sign on attempts when the cryptographic key (i.e., the encryption key) has expired. The cryptographic/encryption key is used to transmit sensitive data between the meter and the computer over the network.



- The Admin can set an expiration time for the cryptographic/encryption key. When the cryptographic/encryption key has expired, any user login is rejected. If a user tries to log in more than five times after the cryptographic/encryption key is expired, that user is locked out for 24 hours, even if the cryptographic/encryption key gets updated. The user will be unblocked if either cryptographic/encryption key expiration is disabled or the lockout time is over.
 - If the Admin is logged in when the encryption key expires, the Admin still has full rights and then can enable/disable the encryption key expiration. If the encryption key has already expired, the Admin user will be able to sign on, but will only have rights to update the encryption key or passwords. The Admin must sign out and then sign in again to disable encryption key expiration.
-
- The amount of time before the cryptographic/encryption key expires, is shown toward the bottom of the screen.
 - The **Prev Page** button returns you to the first Security screen.
 - The **Update** button refreshes the screen with new lockout/expiration times.
 - The **Back** button returns you to the main Fixed System screen.

6.3 Dynamic Screens

All of the Dynamic screens show the time and date at the bottom of the screen. With the exception of the Home screen, all of the Dynamic screens have buttons on the top that allow you to navigate to the Fixed Main screen, the next screen in sequence, the previous screen, and the Dynamic Home screen. There is also a **Play/Pause** button that stops and starts the scrolling between Dynamic screens. You can adjust the screen rotation, which lets you mount the meter vertically as well as horizontally, and you can select the display language (see Display Settings on page 6-24). You can also modify the Dynamic screens - see Appendix C: Using the Display's Editor on page C-1, for instructions.

Home Screen:

This is the first Dynamic screen shown after the system boots up. Touch the buttons to access the following screens:

- Trends: the Dynamic Trends screen
- Alarms: the Dynamic Alarms screen
- Real Time: the Real Time Readings screen
- Power Quality: the Harmonics screen
- Main: the Dynamic Main screen

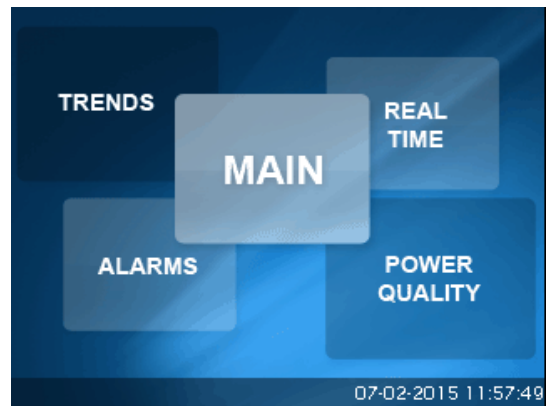

(Dynamic) Main Screen:

This is a navigation screen for the Dynamic screens that are in scroll mode.

Touch the button of the screen you want to access. Each of the screens is described in the following sections.



Real Time:

Brings you to an overview of Real Time Readings consisting of the following:

- Volts AN/BN/CN/AB/BC/CA
- Amps A/B/C
- Watts
- VARS
- VA
- FREQ



Volts:

Brings you to Voltage readings details, consisting of the following:

- Real time Volts AN/BN/CN/AB/BC/CA
- Maximum Volts AN/BN/CN/AB/BC/CA
- Minimum Volts AN/BN/CN/AB/BC/CA

Touch **PH-N**, **PH-PH** or **PH-E** to view details of Phase-to-Neutral, Phase-to-Phase or Phase-to-Earth readings.

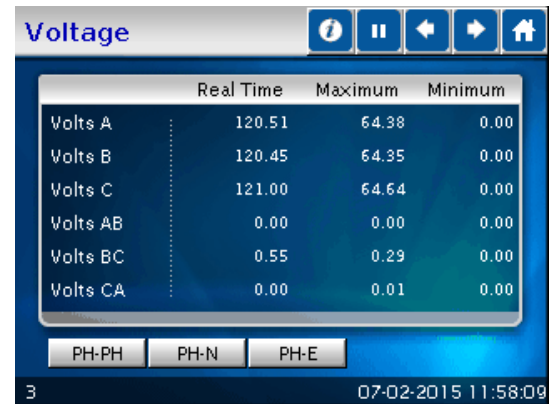

Volts: Voltage Readings PH-N

Volts AN/BN/CN

- Touch the **Back** button to return to the Volts screen.
- Touch the **Next/Previous** arrows to go to Voltage Reading PH-PH and Current Reading A-B-C.
- Touch the **Home** button to go to the Dynamic Home screen.

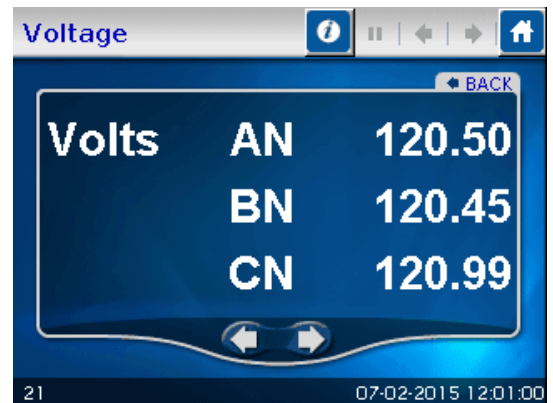

Volts: Voltage Readings PH-PH

Volts AB/BC/CA

- Touch **Back** to return to the Volts screen.
- Touch **Next/Previous** arrows to go to Voltage Reading PH-E and PH-N Readings.
- Touch the **Home** button to go to the Dynamic Home screen.

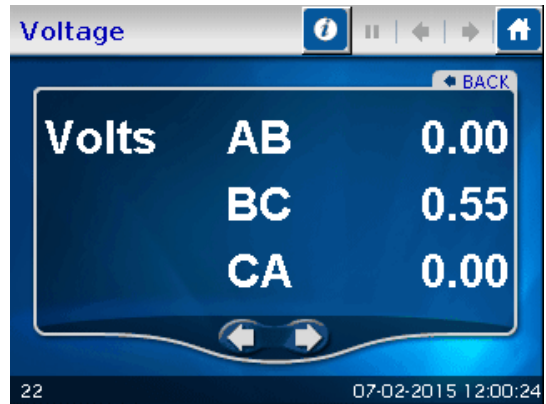

Volts: Voltage Readings PH-E

Volts AE/BE/CE/NE

- Touch **Back** to return to the Volts screen.
- Touch **Next/Previous** arrows to go to Current Reading A-B-C and Voltage Reading PH-PH.
- Touch the **Home** button to go to the Dynamic Home screen.

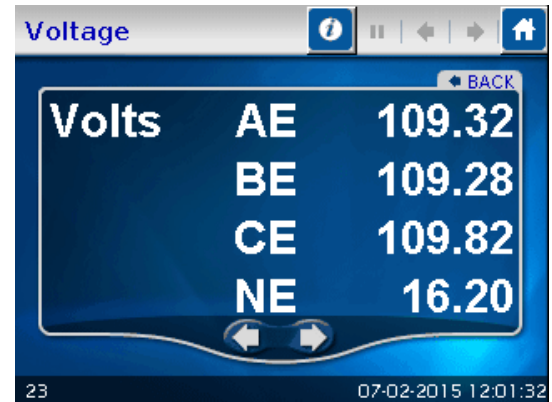

Current:

Brings you to current readings details, consisting of the following:

- Real time current A/B/C
- Maximum current A/B/C
- Minimum current A/B/C
- Current calculated Nc/ measured Nm
- Maximum Current calculated Nc/measured Nm
- Minimum Current Calculated Nc/Measured Nm

Touch **A-B-C** to view Currents Detail.

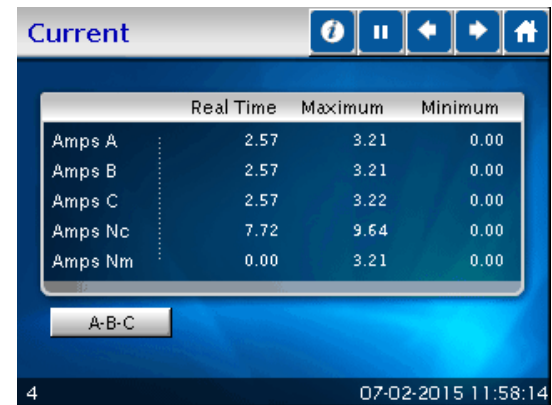

Amps: Current Readings A-B-C

Real Time Current A/B/C

- Touch **Back** to return to the Amps screen.
- Touch **Next/Previous** arrows to go to Voltage Reading PH-N and Voltage Reading PH-PH.
- Touch the **Home** button to go to the Dynamic Home screen.



Power:

Power Readings Details

- Instant Watt/VAR/VA/PF
- Thermal Watt/VAR/VA/PF
- Predicted Watt/VAR/VA

Touch **Demand** to go to the Demand screen (shown below).



Demand:

Demand Readings Details

- Thermal Window Average Maximum +Watt/+VAR/Coln VAR
- Block (Fixed) Window Average Maximum +Watt/+VAR/Coln VAR
- Predictive Rolling (Sliding) Window Maximum +Watt/+VAR/Coln VAR

Touch **R/T** to view the Power screen.



Energy:

Brings you to Accumulated Energy Information, consisting of the following:

- -Watthr Quadrant 2+Quadrant 3 (Primary)
- +VAhr Quadrant 2 (Primary)
- +VARhr Quadrant 2 (Primary)
- +VAhr Quadrant 3 (Primary)
- -VARhr Quadrant 3 (Primary)
- +Watthr Quadrant 1+Quadrant 4 (Primary)
- +VAhr for all quadrants (Primary)



Touch **TOU** to view the TOU Register Accumulations screen.

TOU:

Brings you to TOU Information, consisting of the following:

- Billing Period
- Rates
- TOU Channels
- Accumulators - click the button at the bottom of the screen to view.
- Peak Demand - click the button at the bottom of the screen to view.
- Coincident Demand - click the button at the bottom of the screen to view.
- Cumulative Demand - click the button at the bottom of the screen to view.

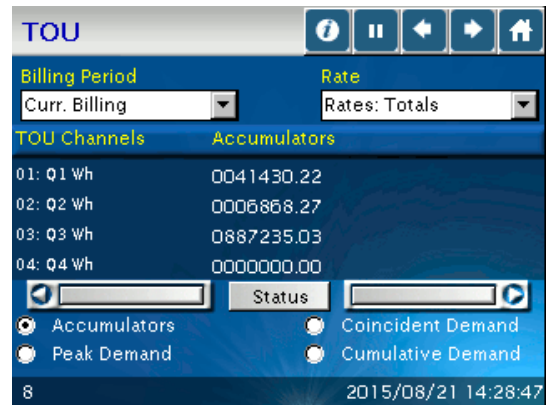

Touch **Peak Demand** to view the Register Peak Demand screen.

Touch **Next/Previous** arrows to scroll Registers 1 - 8 and Totals.

Touch **Next/Previous** arrows to scroll Frozen, Prior Month, Active, and Current Month.

NOTE: If password protection is enabled for the meter a keyboard screen displays, allowing you to enter the password. If a valid password is entered, the TOU data readings are displayed; otherwise a message displays, indicating that the password is invalid.

Phasors:

Brings you to Phasor Analysis Information.

- **Phase/Phasor** arrow buttons change the rotation of the diagram. Note that you can click on the arrows to change the display directions from clockwise to counter-clockwise.
- **Phase/Mag** button shows the phase/magnitude of:
 - Phase angle or magnitude Van/bn/cn
 - Phase angle or magnitude Ia/b/c
 - Phase angle or magnitude Vab/bc/ca
- The **PH-PH** check box shows/hides the phase to phase voltage.

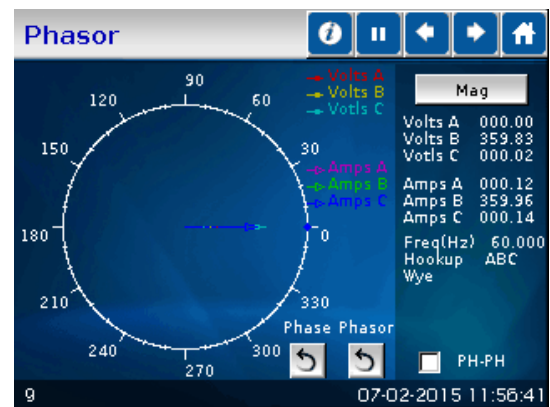
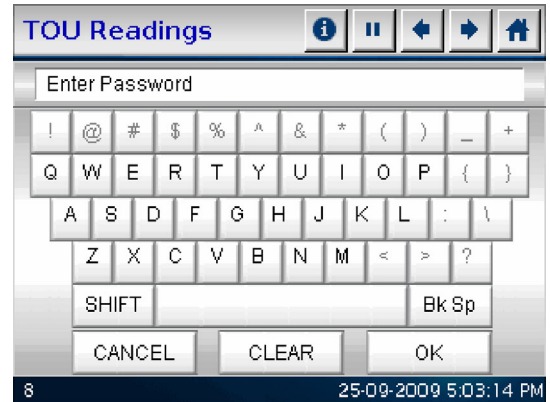

Harmonics-Spectrum:

Brings you to Harmonic Spectrum Analysis information, consisting of the following:

- %THD
- TDD (current only)
- KFactor
- Frequency
- Phase A - N Voltage

Touch **Waveform** to see the channel's waveform.

Touch **Volts BN** to view the Harmonics screen for Phase B - N voltage; Touch **Volts CN** (from the Volts BN screen) to view the Harmonics screen for Phase C - N voltage.

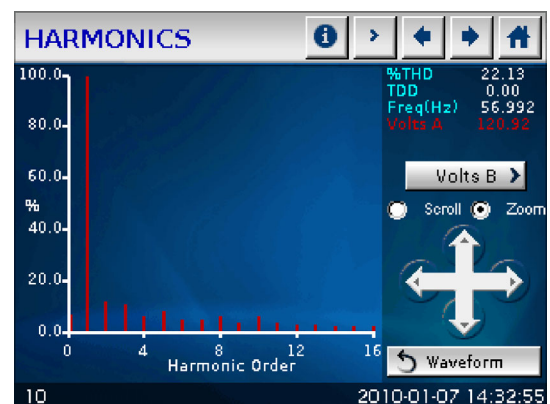

Use the **Scroll/Zoom** radio buttons to select the mode of the directional arrows:

- If Scroll is selected, the directional arrows move the axes horizontally/vertically.
- If Zoom is selected, the directional arrows cause the display to zoom in/out.

Harmonics:

Brings you to the Waveform: Real Time Graph, showing the following information:

- %THD
- TDD (current only)
- KFactor
- Frequency

Touch **Spectrum** to see the Harmonic Spectrum Analysis screen for the channel.

Touch **Volts B** to view the Harmonics screen for Phase B - N voltage; Touch **Volts C** (from the Volts B screen) to view the Harmonics screen for Phase C - N voltage.

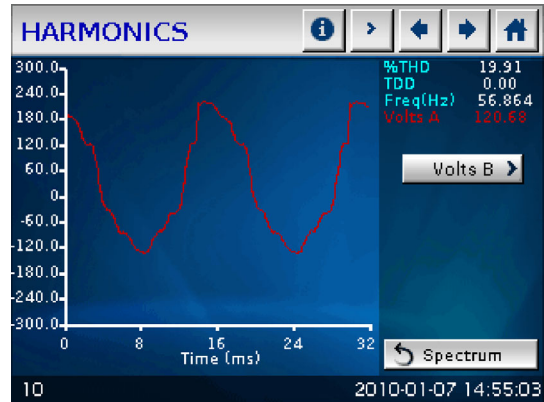

Alarms:

Brings you to Alarm (Limits) Status information, consisting of the following:

- Current Limits settings for the meters, ID 1 - 32.
- For each ID number, the type of reading, value, status and setting is shown.
 - The green rectangle indicates a Within Limits condition and the red rectangle indicates an Out of Limits condition.
 - The first screen displays the settings for Meters ID 1 to 4.

The screenshot shows the 'Alarms' screen with a table of alarm settings:

ID	ITEM	VALUE	STATUS	SETTING
1	1sIntTemp	53.00	Green	10.00
2	1sIntTemp	53.00	Red	70.00
3				
4				
5				

The bottom status bar shows '11' and '07-02-2015 11:56:54'.

Touch **Next/Previous** arrows to view all of the Limits.

Flicker:

Brings you to Flicker Instantaneous information, consisting of the following:

- Time: Start/Reset, Current, Next
- PST, Next PLT
- Frequency
- Base Voltage
- Voltage readings

Touch **PST** (Short Term) or **PLT** (Long Term) to view other flicker screens.

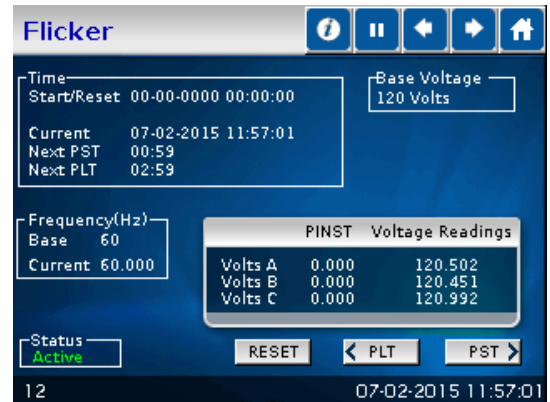

Flicker - Short Term:

Displays the following information:

- Volts A/B/C
- Max Volts A/B/C
- Min Volts A/B/C

Touch **PINST** (Instantaneous) or **PLT** (Long Term) to view other flicker screens.



Flicker - Long Term:

Displays the following information:

- Volts A/B/C
- Max Volts A/B/C
- Min Volts A/B/C

Touch **PINST** (Instantaneous) or **PST** (Short Term) to view other flicker screens.



NOTE: If password protection is enabled for the meter a keyboard screen displays when you press any action button (e.g., **Reset**). Use the keyboard to enter the password. If a valid password is entered, the requested Flicker action takes place; otherwise a message displays, indicating that the password is invalid.



Bargraph:

Brings you to a Bargraph display, consisting of the following:

- Phase AN Voltage
- Phase BN Voltage
- Phase CN Voltage

Touch the **Up/Down** arrows to move the vertical axis up/down.

Touch the **+/-** buttons to zoom in/out.

Touch **Show All** to display all of the bars in the screen.

Touch **Volts PH-PH** to view the Voltage Phase-to-Phase Bargraph screen.

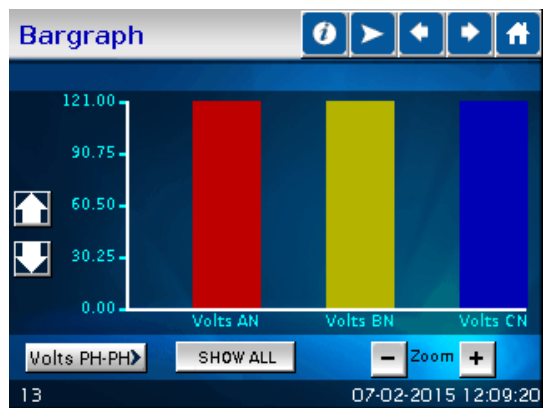

Touch **Current** to view the Amps Bargraph screen. (The Current button is displayed on the Voltage Phase-to-Phase Bargraph screen.)

Reset:

Brings you to the Meter Reset Command screen. From this screen, you can reset the following values:

- Max/Min and Demand
- Hour, I2T and V2T counters
- All logs
- TOU for current month
- TOU active



NOTICE

WARNING! RESETS CAUSE DATA TO BE LOST.

- Touch the box(es) to select the Reset you want to perform.
- Touch **Reset**. All boxes are unchecked after a reset is performed and a check mark is displayed next to each item that was reset.



NOTE

If password protection is enabled for the meter a keyboard screen displays, when you press the Reset button. Use the keyboard to enter the password. If a valid password is entered, the reset takes place; otherwise a message displays, indicating that the password is invalid.

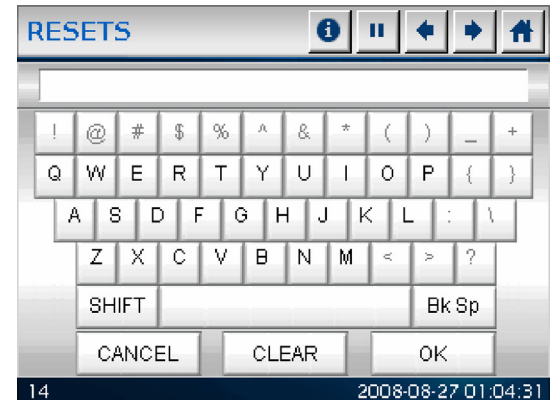

Trends:

Brings you to the Trends Setting screen. From this screen, you can set the following for viewing:

- Interval Log 1 or Log 2: touch the radio button of the log you want.
- Channel: select a channel by touching its button.

You will see the Trends - Graphic screen.

NOTES:

- The active channel appears at the lower right of the display.
- Data from the previously active channel is lost if the channel is changed.



Real Time Trending Graphic:

Trending for the channel selected from the Trends - Setting screen is shown on this screen.

- Touch the **Directional** arrows to see additional points on the graph. You can view up to 240 points at a time.
- To see a table of logs for the Selected Channel, touch **Table** to view the Trends - Table screen.
- Touch **Setting** to select another log and/or channel.

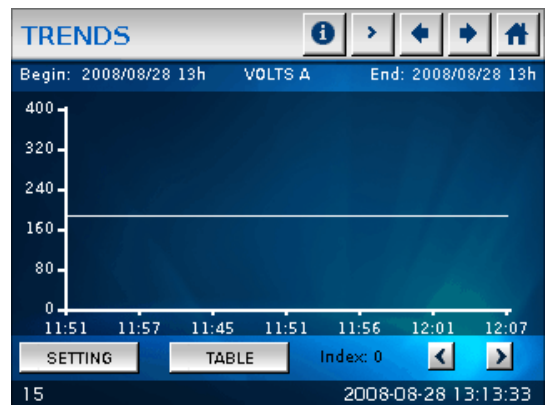

Real Time Trending Table:

A Table of logs for the selected channel (Volts AN is shown here).

- Touch **Graphic** to return to the Trending - Graphic screen.
- Touch **Setting** to select another log and/or channel.

The screenshot shows the 'TRENDS' screen with a table of logs. The table has columns for 'TIME' and 'LOGS' repeated three times. The data shows voltage readings at various times on 2008/08/28. At the bottom, there are buttons for 'SETTING' and 'GRAPHIC', and a status bar with '15' and '2008-08-28 13:12:40'.

TIME	LOGS	TIME	LOGS	TIME	LOGS
11:51	185.17	11:52	185.14	11:53	185.25
11:51	185.17	11:52	185.14	11:53	185.25
11:51	185.17	11:52	185.14	11:54	185.20
11:51	185.17	11:53	185.14	11:54	185.20
11:51	185.17	11:53	185.25	11:54	185.20
11:52	185.14	11:53	185.25	11:54	185.20
11:52	185.14	11:53	185.25	11:54	185.20
11:52	185.14	11:53	185.25	11:54	185.20



If password protection is enabled for the meter, a keyboard screen displays when you press any channel button. Use the keyboard to enter the password. If a valid password is entered, the Trend graphic/Tables are displayed; otherwise a message displays, indicating that the password is invalid.

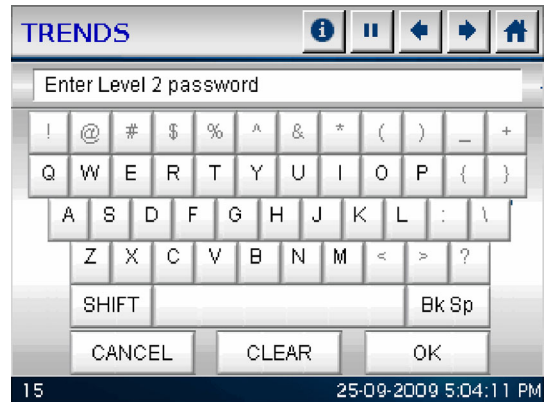

Log Status:

Brings you to Logging Status information, consisting of an overview of the meter's logs. For each log, the following information is listed:

- The number of records
- Record size
- % of memory used¹

Touch the **Next/Previous** arrows to view additional logs.

The screenshot shows the 'Log Status' screen with a table of logging intervals. The table has columns for 'Log Name', '#Records', 'Record Size', and 'Memory Used %'. The data shows six intervals with varying record counts and memory usage. At the bottom, there are navigation arrows and a status bar with '16' and '07-02-2015 11:57:28'.

Log Name	#Records	Record Size	Memory Used %
Interval 1	31128	128	100.0000
Interval 2	31128	128	100.0000
Interval 3	74465	92	11.4627
Interval 4	0	92	0.0000
Interval 5	0	92	0.0000
Interval 6	0	92	0.0000

Firmware Version:

This screen displays the current firmware version for the EPM 9900P meter, as well as the meter designation and serial number. The following information is displayed:

- Device name
- Serial number
- Comm Boot
- Comm Runtime
- DSP
- FPGA
- Touch Screen

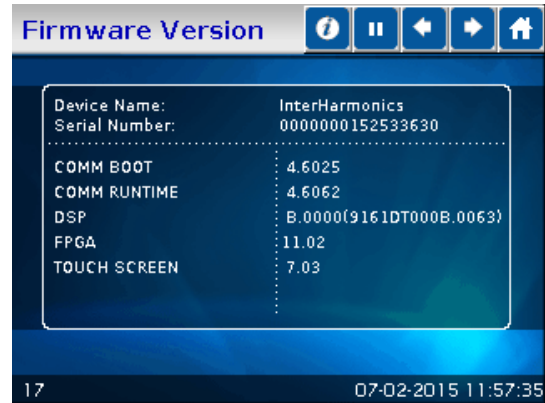

DISPLAY SETTINGS:

Brings you to a screen where you can configure settings for the LCD display. Set the following:

- Contrast: touch **Left/Right** arrows to increase/decrease the contrast for the display.
- Backlight: the number of minutes after use that the display's backlight turns off.
 - Touch **Left/Right** arrows to increase/decrease settings. To keep the backlight on, make this setting "0."
 - To turn the Backlight on press and hold the switch on the front panel beside the display for a few seconds.

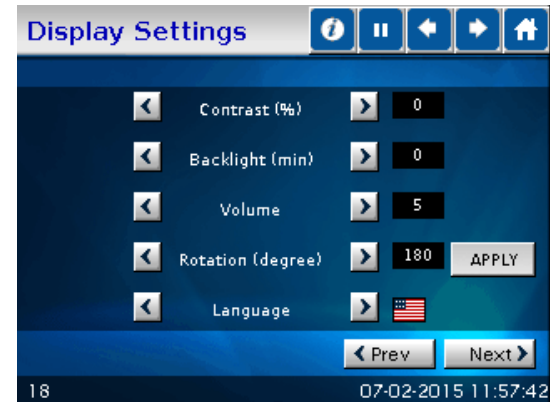

- Volume: touch **Left/Right** arrows to increase/decrease the speaker volume.
- Rotation (degree): touch **Left/Right** arrows to set screen's rotation to 0, 90, 180 or 360 degrees. This allows the meter to be mounted vertically.
- Language: touch **Left/Right** arrows to choose one of the embedded languages or one of the two customized languages, for the display. The choices are: English (ENG), Chinese (CHN), Hebrew (HBW), Portuguese (POT), Spanish (SPN), French (FRN), user's customized 1 (CT1) and user's customized 2 (CT2). See Appendix C: Using the Display's Editor on page C-1, for instructions on creating the customized languages.



You must press **Apply** for your Rotation and Language settings to be implemented. Once you press **Apply**, the screen darkens momentarily and then the Home screen is redisplayed with the selected rotation/language.

Touch **Next/Prev** to go to the Serial Setting/Network Setting screens.

EPM 9900P Serial Communication Settings:

Select the serial communication mode you want to configure, by checking the **Radio Button** to the left of it. The setting for each port is described below:

- Optical port (Baud, Parity, Stop bit, Data size, Protocol, Tx delay, Address, Mode)
- USB (Baud, Parity, Stop bit, Data size, Protocol, Tx delay, Address)
- COMM 1 (Baud, Parity, Stop bit, Data size, Protocol, Tx delay, Address)
- COMM 2 (Baud, Parity, Stop bit, Data size, Protocol, Tx delay, Address, Mode)

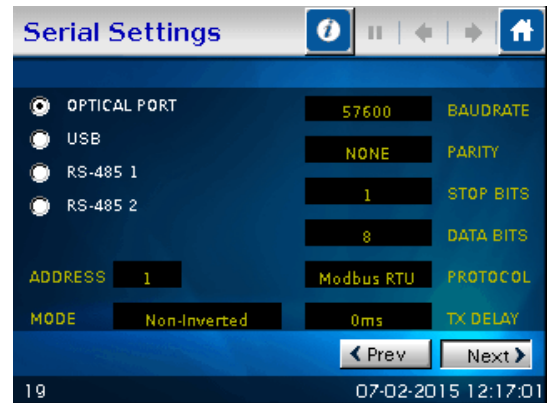

Touch **Next/Prev** to go to the Network Setting/Display Setting screens.

EPM 9900P Network Communication Settings:

Use the following fields to configure the meter's Network settings:

- Network: click the **Radio Button** next to Network 1 or Network 2.
- IP address
- Subnet mask2
- Default gateway
- MAC address

Touch **Next/Prev** to go to the Display Setting/Serial Setting screens.

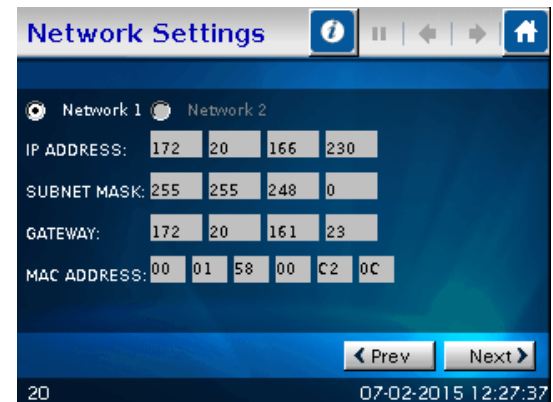

Digital Inputs:

This screen displays the status of the meter’s digital inputs: the eight built-in digital inputs or the digital inputs from an installed Option board. The meter supports up to 2 optional digital input boards (each with 16 status inputs), in addition to the built-in inputs.

- Inputs - 01-16
- Name - the name configured for the input
- State - the input’s state, e.g., Open or Closed. The State names are configured in the meter’s Device Profile settings.
- Slots - Select Slot 3, Slot 4, or Built-In to see the digital inputs for those options.



Only the buttons for slots 3 and 4 are visible if there is a digital input board installed in that slot.

Multilin™ EPM 9900P

Chapter 7: Transformer Loss Compensation

7.1 Introduction

The Edison Electric Institute's Handbook for Electricity Metering, Ninth Edition defines Loss Compensation as:

A means for correcting the reading of a meter when the metering point and point of service are physically separated, resulting in measurable losses including I²R losses in conductors and transformers and iron-core losses. These losses may be added to or subtracted from the meter registration.

Loss compensation may be used in any instance where the physical location of the meter does not match the electrical location where change of ownership occurs. Most often this appears when meters are connected on the low voltage side of power transformers when the actual ownership change occurs on the high side of the transformer. This condition is illustrated in Figure 7.1.

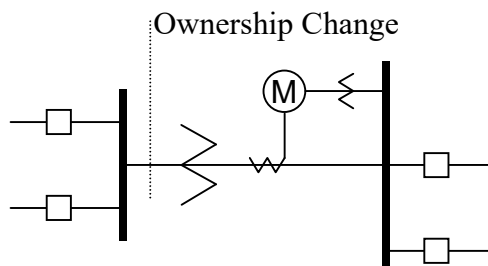

Figure 7-1: Low Voltage Metering Installation Requiring Loss Compensation

It is generally less expensive to install metering equipment on the low voltage side of a transformer and in some conditions other limitations may also impose the requirement of low-side metering even though the actual ownership change occurs on the high voltage side.

The need for loss compensated metering may also exist when the ownership changes several miles along a transmission line where it is simply impractical to install metering equipment. Ownership may change at the midway point of a transmission line where there are no substation facilities. In this case, power metering must again be compensated. This condition is shown in Figure 7.2.

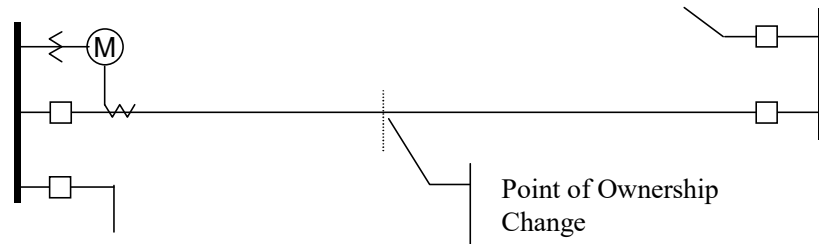

Figure 7-2: Joint Ownership Line Meeting Requiring Loss Compensation

A single meter cannot measure the losses in a transformer or transmission line directly. It can, however, include computational corrections to calculate the losses and add or subtract those losses to the energy flow measured at the meter location. This is the method used for loss compensation in the EPM 9900P meter. Refer to the *GE Communicator Instruction Manual* for detailed explanation and instructions for using the Transformer Line Loss Compensation feature of the EPM 9900P meter.

The computational corrections used for transformer and transmission line loss compensation are similar. In both cases, no-load losses and full-load losses are evaluated and a correction factor for each loss level is calculated. However, the calculation of the correction factors that must be programmed into the meter differ for the two different applications. For this reason, the two methodologies will be treated separately in this chapter.

In the EPM 9900P meter, Loss Compensation is a technique that computationally accounts for active and reactive power losses. The meter calculations are based on the following formulae. These equations describe the amount of active (watts) and reactive (VARs) power lost due to both iron and copper effects (reflected to the secondary of the instrument transformers).

$$W_{TotalTransformerLoss} = VA_{TransformerFullScale} \times \left[\%LFWE \times \left(\frac{V_{measured}}{V_{nominal}} \right)^2 + \%LWCU \times \left(\frac{I_{measured}}{I_{nominal}} \right)^2 \right]$$

$$VAR_{TotalTransformerLoss} = VA_{TransformerFullScale} \times \left[\%LVFE \times \left(\frac{V_{measured}}{V_{nominal}} \right)^4 + \%LVCU \times \left(\frac{I_{measured}}{I_{nominal}} \right)^2 \right]$$

The Values for %LWFE, %LWCU, %LVFE, and %LVCU are derived from the transformer and meter information, as demonstrated in the following sections.

The calculated loss compensation values are added to or subtracted from the measured Watts and VARs. The selection of adding or subtracting losses is made through the meter's profile when programming the meter (see the following section for instructions). The meter uses the combination of the add/subtract setting and the directional definition of power flow (also in the profile) to determine how to handle the losses. Losses will be "added to" or "subtracted from" (depending on whether add or subtract is selected) the Received Power flow. For example, if losses are set to "Add to" and received power equals 2000 kW and losses are equal to 20 kW then the total metered value with loss compensation would be 2020 kW; for these same settings if the meter measured 2000 kW of delivered power the total metered value with loss compensation would be 1980 kW.

Since transformer loss compensation is the more common loss compensation method, the meter has been designed for this application. Line loss compensation is calculated in the meter using the same terms but the percent values are calculated by a different methodology.

7.2 EPM 9900P Transformer Loss Compensation

- Performs calculations on each phase of the meter for every measurement taken; unbalanced loads are handled accurately.
- Calculates numerically, eliminating the environmental effects that cause inaccuracies in electromechanical compensators.
- Performs bidirectional loss compensation.
- Requires no additional wiring; the compensation occurs internally.
- Imposes no additional electrical burden when performing loss compensation.

Loss Compensation is applied to watt/VAR readings and, because of that, affects all subsequent watt/VAR readings. This method results in loss compensation being applied to the following quantities:

- Total power
- Demands, per phase and total (Block (Fixed) window and Rolling (Sliding) window)
- Maximum and minimum Demand
- Energy accumulations
- KYZ output of energy accumulations

The meter provides compensation for active and reactive power quantities by performing numerical calculations. The factors used in these calculations are derived either:

- By clicking the TLC Calculator button on the Transformer Loss screen of the Device Profile, to open the GE Loss Compensation Calculator in Microsoft Excel
- By figuring the values from the worksheet shown in "Three-Element Loss Compensation Worksheet" on page 5, and in the GE Communicator Instruction Manual

Either way, you enter the derived values into the GE Communicator software through the Device Profile Transformer and Line Loss Compensation screen.

The GE Communicator software allows you to enable transformer loss compensation for losses due to copper and iron, individually or simultaneously. Losses can either be added to or subtracted from measured readings. Refer to the *GE Communicator Instruction Manual* for instructions.

Loss compensation values must be calculated based on the meter installation. As a result, transformer loss values must be normalized to the meter by converting the nominal voltage and current and taking into account the number of elements used in the metering installation. For three-element meters, the installation must be normalized to the phase-to-neutral voltage and the phase current; in two-element meters the installation must be normalized to the line-to-line voltage and the line current. This process is described in the following sections.

7.2.1 Loss Compensation in Three Element Installations

Loss compensation is based on the loss and impedance values provided on the transformer manufacturer's test report. A typical test report will include at least the following information:

- Manufacturer
- Unit serial number
- Transformer MVA rating (Self-Cooled)
- Test voltage
- No load loss watts
- Load loss watts (or full load loss watts)
- % Exciting current @ 100% voltage
- % Impedance

The transformer MVA rating is generally the lowest MVA rating (the self-cooled or OA rating) of the transformer winding. The test voltage is generally the nominal voltage of the secondary or low voltage winding. For three-phase transformers these values will typically be the three-phase rating and the phase-to-phase voltage. All of the test measurements are based on these two numbers. Part of the process of calculating the loss compensation percentages is converting the transformer loss values based on the transformer ratings to the base used by the meter.

Correct calculation of loss compensation also requires knowledge of the meter installation. In order to calculate the loss compensation settings you will need the following information regarding the meter and the installation:

- Number of meter elements
- Potential transformer ratio (PTR)
- Current transformer ratio (CTR)
- Meter nominal voltage
- Meter nominal current

This section is limited to application of EPM 9900P meters to three-element metering installations. As a result, we know that:

- Number of metering elements = 3
- Meter nominal voltage = 120 Volts
- Meter nominal current = 5 Amps

Three-Element Loss Compensation Worksheet

If you are not using the TLC Calculator in the GE CCommunicator software, use the worksheet in this section to calculate the values to use for the meter’s Transformer and Line Loss compensation. Note that the instructions for one of the worksheet tables directly follows the table.

Company		Station Name	
Date		Trf. Bank No.	
Trf Mfg		Trf Serial No.	
Calculation by			

1. Enter the general information.

Winding	Voltage	MVA	Connection
HV - High			Δ-Y
XV - Low			Δ-Y
YV - Tertiary			Δ-Y

2. Enter Transformer data (from Transformer Manufacturer’s Test Sheet).

Value	Watts Loss		1-Phase kW
	3-Phase	1-Phase	
No-Load Loss			
Full Load Loss			

3. Enter 3-Phase or 1-Phase values.
 - If 3-Phase values are entered, calculate 1-Phase values by dividing the 3-Phase values by three.
 - Convert 1-Phase Watts Loss to 1-Phase kW by dividing the 1-Phase Watts Loss by 1000.

Value	3-Phase MVA	1-Phase MVA	1-Phase kVA
Self-Cooled Rating			

4. Enter 3-Phase MVA or 1-Phase MVA values.

- If 3-Phase MVA values are entered, calculate 1-Phase MVA values by dividing 3-Phase MVA values by three.
- Convert 1-Phase MVA to 1-Phase kVA by multiplying by 1000.

% Exciting Current	
% Impedance	

5. Enter the % Exciting Current and % Impedance values.

Value	Phase-to-Phase	Phase-to-Neutral
Test Voltage (Volts)		
Full Load Current (Amps)		

6. Enter the Phase-to-Phase values for Test Voltage (Volts) and Full Load Currents (Amps). Note that Test Voltage is generally Phase-to-Phase for 3-Phase transformers.
- Calculate Phase-to-Neutral Test Voltage by dividing Phase-to-Phase Test Voltage by the square root of 3.
 - Calculate Full Load Current (Amps) by dividing the 1-Phase kW self-cooled rating by the Phase-to-Neutral Voltage and multiplying by 1000.

Instrument Transformers	Numerator	Denominator	Multiplier
Potential Transformers			
Current Transformers			
Power Multiplier [(PT Multiplier) x (CT Multiplier)]			

7. Meter/Installation Data: enter the Numerator and Denominator for each instrument transformer. For example, a PT with a ratio of 7200/120 has a numerator or 7200, a denominator or 120 and a multiplier of 60 (7200/120 = 60/1).

Meter Secondary Nominal Voltage (Volts)	120 V
Meter Secondary Nominal Current (Amps)	5 A

8. Meter/Installation Data: enter the Meter Secondary Nominal Voltage (Volts) and Meter Secondary Nominal Current (Amps).

Quantity	Transformer	Multiplier	Trf IT Sec (Instrument Transformer Secondary Value)	Meter Nominal	Meter/Trf (Meter-Transformer Ratio)
Voltage				120	
Current				5	

9. Conversion Factors for Nominal Value:

- For Transformer Voltage, enter the Phase-to-Neutral of Test Voltage (Volts) previously calculated (step 6).
- For Transformer Current, enter the Full Load Current (Amps) previously calculated (step 6).
- For Multiplier, enter the PT and CT Multipliers previously calculated (step 7).
- Trf IT Sec is the nominal value of voltage and current at the instrument transformer secondary. These numbers are obtained by dividing the Transformer Voltage and Transformer Current by their respective Multiplier.
- The Meter/Trf values for Voltage and Current are obtained by dividing the Meter Nominal by the Trf IT Sec.

10. Normalized Losses: fill out the following section of the worksheet:

No-Load Loss Watts (kW) = 1-Phase kW No-Load Loss = _____

No-Load Loss VA (kVA) = (%Exciting Current) * (1-Phase kVA Self-Cooled Rating) / 100 = (_____) * (_____) / 100
 = _____ kVA

No-Load Loss VAR (kVAR) = SQRT((No-Load Loss kVA)² - (No-Load Loss kW)²) = SQRT((_____)² - (_____)²)
 = SQRT((_____) - (_____))
 = SQRT (_____) = _____

Full-Load Loss Watts (kW) = 1-Phase Kw Load Loss = _____

Full-Load Loss VA (kVA) = (%Impedance) * (1-Phase kVA Self-Cooled Rating) / 100 = (_____) * (_____) / 100
 = _____ kVA

Full-Load Loss VAR (kVAR) = SQRT((Full-Load Loss kVA)² - (Full-Load Loss kW)²) = SQRT((_____)² - (_____)²)
 = SQRT((_____) - (_____))
 = SQRT (_____) = _____

Quantity	Value at Trf Nominal	M/T Factor	Meter/Trf Value (Meter Transformer Ratio)	Exp	M/T Factor w/ Exp	Value at Meter Nominal
No-Load Loss Watts (kW)		Voltage		^{^2}		
No-Load Loss VAR (kVAR)		Voltage		^{^4}		
Full Load Loss Watts (kW)		Current		^{^2}		
Full Load Loss VAR (kVAR)		Current		^{^2}		

11. Normalize Losses to Meter Nominal Power:

- Enter Value at Trf Nominal for each quantity from previous calculations (step 10).

- Enter Meter/Trf Value from Conversion Factors for Nominal Values (step 9).
- Calculate M/T Factor w/Exp by raising the Meter/Trf Value to the power indicated in Exp.
- Calculate the Value at Meter Nominal by multiplying the M/T Factor w/Exp by the Value at Trf Nominal.

12. Loss Watts Percentage Values: fill out the following section of the worksheet:

$$\begin{aligned} \text{Meter Nominal kVA} &= 600 * (\text{PT Multiplier}) * (\text{CT Multiplier}) / 1000 \\ &= 600 * (\text{_____}) * (\text{_____}) / 1000 \\ &= \text{_____} \end{aligned}$$

Quantity	Value at Meter Nominal	Meter Nominal kVA	% Loss at Meter Nominal	Quantity
No-Load Loss W (kW)				% Loss Watts FE
No-Load Loss VAR (kVAR)				% Loss VARs FE
Full Load Loss W (kW)				% Loss Watts CU
Full Load Loss VAR (kVAR)				% Loss VARs CU

13. Calculate Load Loss Values:

- Enter Value at Meter Nominal from Normalize Losses (step 11).
- Enter Meter Nominal kVA from previous calculation (step 12).
- Calculate % Loss at Meter Nominal by dividing Value at Meter Nominal by Meter Nominal kVA and multiplying by 100.
- Enter calculated % Loss at Meter Nominal Watt values into the EPM 9900P meter using GE Communicator software. Refer to the GE Communicator Instruction Manual for additional instructions.

Multilin™ EPM 9900P

Chapter 8: Time-of-Use Function

8.1 Introduction

In response to both higher energy costs and concern for energy conservation (oftentimes spurred on by governmental regulations), many utilities have adopted strategies for load management. Time of Use (TOU) metering is one of these strategies. TOU is a means of accumulating usage during specified time periods with the purpose of billing with different rates for the different periods; for example, off-peak versus on-peak usage, and weekday versus weekend usage. So, a TOU usage structure takes into account both the quantity of energy used and the time at which it was consumed. TOU metering by utilities lets them charge a higher rate for electricity used when it is more expensive to produce and distribute, i.e., a Peak Demand period. In this way the utility tries to reward usage during lower demand periods and curtail usage during higher demand periods, by charging more or less for equivalent energy use.

The EPM 9900P meter's TOU function, available with the GE Communicator software, lets you set up a TOU profile to meet your application needs. It has been developed to offer a variety of programmable rate structures, for maximum flexibility. Once programmed, the EPM 9900P meter's TOU function accumulates data based on the time-scheme you programmed into the meter. See the figure on the next page for a graphical representation of TOU.

See the *GE Communicator Instruction Manual* for details on programming the EPM 9900P meter's 20-year TOU calendar and retrieving TOU data.

Time of Use

Energy use is binned according to the time it is used, so that it can be billed for appropriately.

To set up the bins (that is, the rates), you can use:

Seasons 1-4

Months 1-12

Type of Days (Weekend/Weekday/Holiday)

Time of Day Bins (Rates)

For Example: Off-Peak=Lowest Energy Usage Cost
On-Peak=Highest Energy Usage Cost
Shoulder Peak=Middle Energy Usage Cost

TOU example: Season One, Month 1

Weekdays **Off Peak 12 am-7:59am**
On Peak 8 am - 5:59pm
Shoulder Peak 6 pm - 7:59 pm
Off Peak 8 pm-11:59pm

Weekends **Off Peak 12 am-11:59pm**

Holidays **Off Peak 12 am-11:59pm**

Monday: the day's usage is binned as shown below:

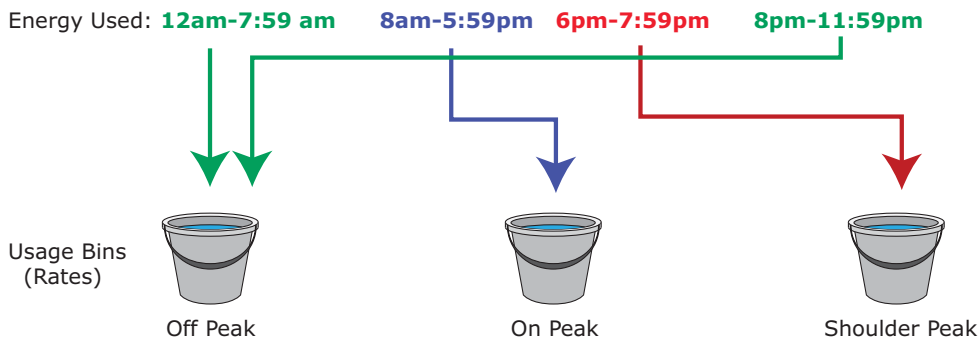

8.2 The EPM 9900P Meter's TOU Profile

A EPM 9900P meter's TOU profile sets the parameters for TOU data accumulation into rate bins. Features of the meter's TOU implementation include:

- The meter uses a perpetual TOU scheme, so you only need to set up the TOU profile once and then you can apply it to all subsequent years.
- You can save the TOU profile as a file and easily import it into any other EPM 9900P meters that you have.
- You can set up to 16 daily schedules, e.g., Weekday, Weekend, or Holiday, or any type of daily schedule you need.
- You can set up to four Season types, which can also be customized as daily or weekly schedules.
- You can set up to 12 Month types.
- Season and month end time can be customized as needed.
- The meter has 38 available accumulators for TOU; 16 accumulators can be tracked in a TOU profile.

8.3 TOU Prior Season and Month

The EPM 9900P meter stores accumulations for the prior season and the prior month. When the end of a billing period is reached, the current season or month is stored as the prior data. The registers are then cleared and accumulations resume, using the next set of TOU schedules and register assignments from the stored calendar. Prior and current accumulations to date are always available.

8.4 Updating, Retrieving and Replacing TOU Profile

GE Communicator software retrieves the TOU Profile from the EPM 9900P meter or from the computer's hard drive for review and edit. Accumulations do not stop during TOU profile updates, but once you have made your changes and updated the meter, the meter performs a self-read and the current month and season data blocks are moved to the prior data blocks, and the current data blocks and all accumulator "buckets" are cleared. See the *GE Communicator Instruction Manual* for instructions on updating the TOU profile.

8.5 Daylight Savings and Demand

To enable Daylight Savings Time for the meter: from the Device Profile menu click **General Settings>Time Settings**. In the Time Settings screen, click Auto DST, which sets Daylight Savings Time automatically (for the United States only). You can also select User Defined and enter the desired dates for Daylight Savings Time. See the *GE Communicator Instruction Manual* for instructions.

To set Demand intervals: from the Device Profile menu click **Revenue and Energy Settings>Demand Integration Intervals** and set the desired intervals. See the *GE Communicator Instruction Manual* for instructions.

To set Cumulative Demand Type, from the Device Profile menu click **Revenue and Energy Settings>Cumulative Demand Type** and select **Block** or **Rolling Window Average**. See the *GE Communicator Instruction Manual* for instructions.

Multilin™ EPM 9900P

Chapter 9: EPM 9900P Network Communications

9.1 Hardware Overview

The EPM 9900P meter can connect to multiple PCs via Modbus/TCP over the Ethernet or via a DNP LAN/WAN connection.

Figure 9-1: EPM 9900P Meter Connected to Network

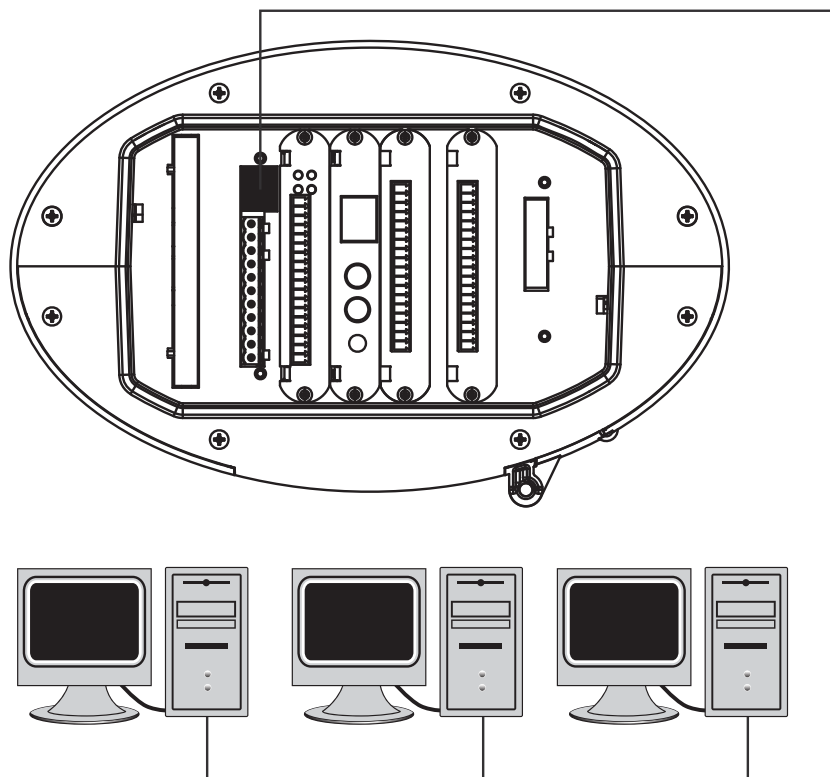

The EPM 9900P meter's Network is an extremely versatile communications tool. It:

- Adheres to IEEE 802.3 Ethernet standard using TCP/IP

- Utilizes simple and inexpensive 10/100BaseT wiring and connections
- Plugs into your network using built-in RJ45 jack
- Is programmable to any IP address, subnet mask and gateway requirements
- Communicates using the industry-standard Modbus/TCP and DNP LAN/WAN protocols

Multiple simultaneous connections (via LAN) can be made to the EPM 9900P meter. You can access the EPM 9900P meter with SCADA and RTU simultaneously.

Multiple users can run GE Communicator software to access the meter concurrently.

9.2 Specifications

The EPM 9900P meter's main Network card (standard) has the following specifications at 25 °C:

Number of Ports: 1

Operating Mode: 10/100BaseT

Connection type: RJ45 modular (Auto- detecting transmit and receive)

Diagnostic feature: Status LEDs for LINK and ACTIVE

Number of simultaneous Modbus connections:

32 (64 total connections over both the main Network card and optional Network card 2.)

Number of simultaneous DNP LAN/WAN connections to the meter:

2 TCP and 1 UDP per Network card

For details on the Network cards IEC 61850 Protocol server, see Appendix B: *IEC 61850 Ethernet Network Server*.

9.3 Network Connection

Use standard CAT5E network cables to connect with the EPM 9900P meter. The RJ45 line is inserted into the RJ45 port on the back of the meter (see Figure 9-1).

Set the IP Address using the following steps:

(Refer to the *GE Communicator Instruction Manual* for detailed instructions.)

1. From the Device Profile screen, double-click **General Settings> Communications**, then double-click on any of the ports. The Communications Settings screen opens.
2. In the Network Settings section enter the following data.



The settings shown below are the default settings of the main Network card. See Chapter 11 for the default settings of optional Network card 2.

- IP Address: 10.0.0.1
- Subnet Mask: 255.255.255.0
- Default Gateway: 0.0.0.0



You can use different settings for the main Network card (check with your Network Administrator for the correct settings).

We recommend the main Network card and Network card 2 be in different subnets, though this is not a necessity.

3. Once the above parameters have been set, GE Communicator connects via the network using a Device Address of "1" and the assigned IP Address when you follow these steps:
 - i Open GE Communicator .
 - ii Click the **Connect** icon in the icon tool bar. The Connect screen opens.
 - iii Click the **Network** button at the top of the screen. Enter the following information:

Device Address: 1
Host: The Network card's IP Address
Network Port: 502
Protocol: Modbus TCP
 - iv Click the **Connect** button at the bottom of the screen. GE Communicator connects to the meter via the network.

Network Information Through Display

You can see the Network settings through the meter's Touch Screen display:

1. From the Main screen, select **Setting**.
2. Press the **Next** button twice to go to the Network Settings screen (shown on the next page).
3. Click the button next to Network 1 to see the settings for the standard Ethernet connection. Click the button next to Network 2 to see the settings for the second, optional Network card, if installed.



9.4 Total Web Solutions

The EPM 9900P meter's Network card supports GE VERNOVA's Total Web Solutions, which is a Web server that lets you view meter information over any standard Web browser. The EPM 9900P meter default webpages can be viewed by Internet Explorer, Firefox, Chrome, and Safari web browsers. They can be viewed on PCs, tablet computers and smart phones.

The default webpages provide real-time readings of the meter's voltage, current, power, energy, power quality, pulse accumulations and high speed digital inputs, as well as additional meter information, alarm/email information and diagnostic information. You can also upgrade the meter's firmware through the webpages. You can customize the default webpages - see the *GE Communicator Instruction Manual* for instructions on setting up Total Web Solutions and customizing webpages. The following sections provide information on accessing the default webpages.

9.4.1 Viewing Webpages

The following is information on accessing the default webpages.

1. Open a Web browser on your PC, tablet computer or smart phone.
2. Type the Ethernet Card's IP address in the address bar, preceded by "http://".
For example: http://10.0.0.1
3. You will see the Volts/Amps webpage shown below. It shows voltage and current readings.

Multilin™ EPM 9900P
POWER METERING SYSTEM

Home | Volts/Amps | Power/Energy | Power Quality | Pulse Accumulation | Inputs | Meter Information | Emails | Diagnostic | Tools



Voltage/Freq/Current

Meter Name 180282627

Date/Time 08-18-2016 10:57:00

Voltage/Frequency

	Instantaneous	Maximum	Minimum
Volts AN	69.50	69.44	2.61
Volts BN	69.52	69.54	2.62
Volts CN	69.29	69.38	2.61
Volts A-B	120.40	120.37	4.53
Volts B-C	120.26	120.31	4.52
Volts C-A	120.13	120.15	4.52
Frequency	60.00	60.00	2.26

Current

	Instantaneous	Maximum	Minimum
Amps A	5.14	5.14	0.19
Amps B	5.14	5.13	0.19
Amps C	5.14	5.13	0.19
Amps N (calculated)	5.13	5.13	0.19

Last Max Reset 08-11-2016 14:19:08

- To view power and energy readings, click **Power/Energy** on the left side of the webpage. You see the webpage shown below. Scroll to see all of the information.

Power and Energy

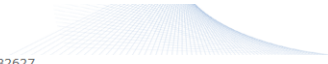

Meter Name 180282627

Date/Time 08-18-2016 10:55:04

Power and Energy

Real Time

	Instant	Thermal	Block	Rolling	Predicted
Watts	-927.52	-927.54	-927.53	-927.52	0.00
VARs	-534.36	-534.12	-534.15	-534.14	0.00
VA	1.07 k	1.07 k	1.07 k	1.07 k	0.00

	Instant	Thermal
PF	-0.866 Lead	-0.866 Lead

Peak Demand

	Thermal	Block	Rolling
Del Watts	0.00	0.00	0.00
Rec Watts	-927.96	-927.93	-927.94
Del Watts Coincident VARs	0.00	0.00	0.00
Rec Watts Coincident VARs	-533.96	-534.15	-534.06
+VARs	1.16	0.00	0.00
-VARs	-534.70	-534.53	-534.53

Energy (Primary)

+ Watt Hour(Q1+4)	397513.31
- Watt Hour(Q2+3)	352376.34
+ VAR Hour(Q1+2)	001891.89
- VAR Hour(Q3+4)	430489.92
VA Hour(Q1+2+3+4)	528168.03

- To view power quality information, click **Power Quality** on the left side of the webpage. You see the webpage shown below.

Power Quality

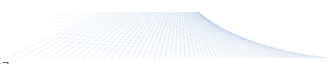

Meter Name 180282627

Date/Time 08-18-2016 10:57:44

Voltage/Current

	%THD									
		1	3	5	7	9	11	13	15	
		Mag.	Mag.	Mag.	Mag.	Mag.	Mag.	Mag.	Mag.	
VA	0.08%	100.00%	0.03%	0.00%	0.00%	0.00%	0.00%	0.00%	0.00%	
VB	0.08%	100.00%	0.04%	0.00%	0.00%	0.00%	0.00%	0.00%	0.00%	
VC	0.00%	100.00%	0.01%	0.00%	0.00%	0.00%	0.00%	0.00%	0.00%	
IA	0.00%	100.00%	0.00%	0.00%	0.00%	0.00%	0.00%	0.00%	0.00%	
IB	0.00%	100.00%	0.00%	0.00%	0.00%	0.00%	0.00%	0.00%	0.00%	
IC	0.00%	100.00%	0.00%	0.00%	0.00%	0.00%	0.00%	0.00%	0.00%	

Last PQ Events

	Number of Events	Date/ Time of Last Event
Waveform	38	08-16-2016 14:07:17
PQ	410	08-02-2016 14:43:16
Transient	0	00-00-0000 00:00:00

- To view pulse accumulation data, click **Pulse Accumulation** on the left side of the webpage. You see the webpage shown below.

Pulse Accumulations

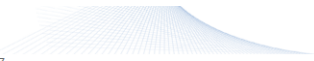

Meter Name 180282627
Date/Time 08-18-2016 10:58:21

Pulse Accumulations

Source	Totals	Average	Maximum	Time Stamp
Gas Meter 1	5	0	0	08-11-2016 14:19:08
Gas Meter 2	6	0	0	08-11-2016 14:19:08
Accumulator3	5	0	0	08-11-2016 14:19:08
Accumulator4	6	0	0	08-11-2016 14:19:08
Accumulator5	5	0	0	08-11-2016 14:19:08
Accumulator6	6	0	0	08-11-2016 14:19:08
Accumulator7	5	0	0	08-11-2016 14:19:08
Accumulator8	6	0	0	08-11-2016 14:19:08

Nexus Watt Hour	Energy
Nexus	0

Aggregator	Totals	Average	Maximum	Time Stamp
Total Gas Meters	1000397512	0	0	08-11-2016 14:19:08
Aggregator 2	0	0	0	08-11-2016 14:19:08
Aggregator 3	0	0	0	08-11-2016 14:19:08
Aggregator 4	0	0	0	08-11-2016 14:19:08

- To view Inputs data, click **Inputs** on the left side of the webpage. You see the webpage shown below.

Inputs



Meter Name 180282627
Date/Time 08-18-2016 10:58:55

Internal Digital Inputs

1	2	3	4	5	6	7	8
●	●	●	●	●	●	●	●

Input	Status
HS_Input 1	Open
HS_Input 2	Open
HS_Input 3	Open
HS_Input 4	Open
HS_Input 5	Open
HS_Input 6	Open
HS_Input 7	Open
HS_Input 8	Open

- To view general meter information, click **Meter Information** on the left side of the webpage. You see the webpage shown below.

Meter Information

System		Run Time Status	
CT Ratio	5.00/5.00	COM State	With extended status: PTCT Calibration Selected IEC 61850 CID IP mismatch
PT Ratio	120.00/120.00	FPGA State	Healthy
System	Wye	DSP State	Healthy
Device Information		Security	
Device Type	EPM 9900+	Password and Sealing Switch	Password Protection Disabled Sealing Switch Disabled
Device Name	180282627		
Boot	15_0000		
Run Time	15_0000		
FPGA	0_11_3		
DSP	15.0000 (9161RE0015.0000)		
Internal Serial #	0000000180282627		
V-Switch	82		
Ethernet 1 Info			
MAC Address	00-01-58-00-c2-41		
IP Address	10.14.30.241		
Subnet Mask	255.255.255.0		
Default Gateway	0.0.0.0		
Ethernet 2 Info			
MAC Address	00-01-58-00-dd-38		
IP Address	10.0.1.1		
Subnet Mask	255.255.255.0		
Default Gateway	0.0.0.0		

- To view alarm/email information, click **Emails** on the left side of the webpage. You see the webpage shown below. Scroll to see all of the information.

Emails

Last 10 stored emails	
Email ID	Date/Time
1 (Newest)	Tue, 16 Aug 2016 14:07:20 -0500
2	Tue, 16 Aug 2016 14:07:17 -0500
3	
4	
5	
6	
7	
8	
9	
10 (Oldest)	

Email ID 1	
Date	Tue, 16 Aug 2016 14:07:20 -0500
Subject	
From	
To	
CC	
Device Name	180282627
Contact Person	Administrator
Contact Phone	0000000000
Alarm ID's	3
Alarm Names	{3} Waveform captured
Alarm Details	Device Name: 180282627 Contact person: Administrator Contact phone: 0000000000 Alarm ID's: 3 Alarm Names: {3} Waveform captured
Send Status	Email send failed, line-99997, SMTP error 0.Couldn't resolve SMTP server name with DNS

[back to top](#)

10. To view detailed information for the meter, click **Diagnostic** on the top of the webpage. You see the webpage shown below. The available diagnostic screens are listed on the page - click on any of the listed items to view its detailed information.

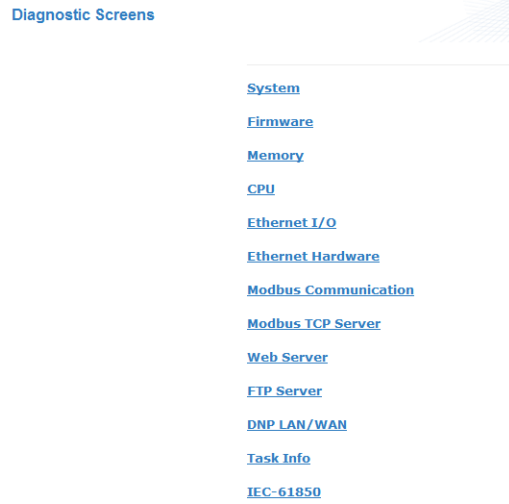

11. To access the web tools available for the meter, click **Tools** on the top of the webpage. The **Tools** link on the left side of the webpage opens the webpage shown below..

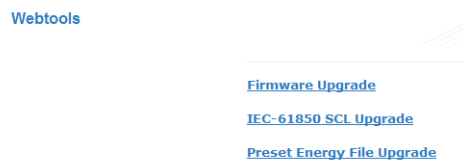

12. To upgrade the meter's firmware, click **Firmware Upgrade**.



NOTE

13. You will see a log on screen. See the example screen shown below.

The server mymetermeter.com at The Meter requires a username and password.

Warning: This server is requesting that your username and password be sent in an insecure manner (basic authentication without a secure connection).

User name
Password
 Remember my credentials

OK Cancel

Enter the correct Username and Password to access the meter and click **OK**.



NOTE

If password protection is not enabled for the meter, the default username and default password are both “**anonymous**”.

14. The webpage “update1.htm” opens. See the example webpage shown below.

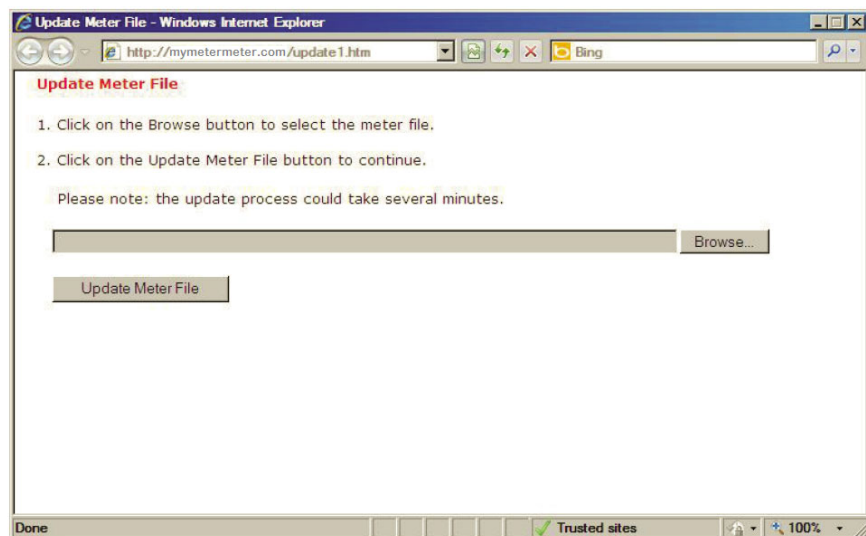

15. Click the **Browse** button to locate the Upgrade file.



NOTE

You must be using the PC on which the upgrade file is stored.

16. Click the **Update Meter File** button to begin the upgrade process. The upgrade starts immediately (it may take several minutes to complete).

17. Once the upgrade is complete, you see a webpage with a confirmation message, shown below. Click the **Reset Meter** button to reset the meter.

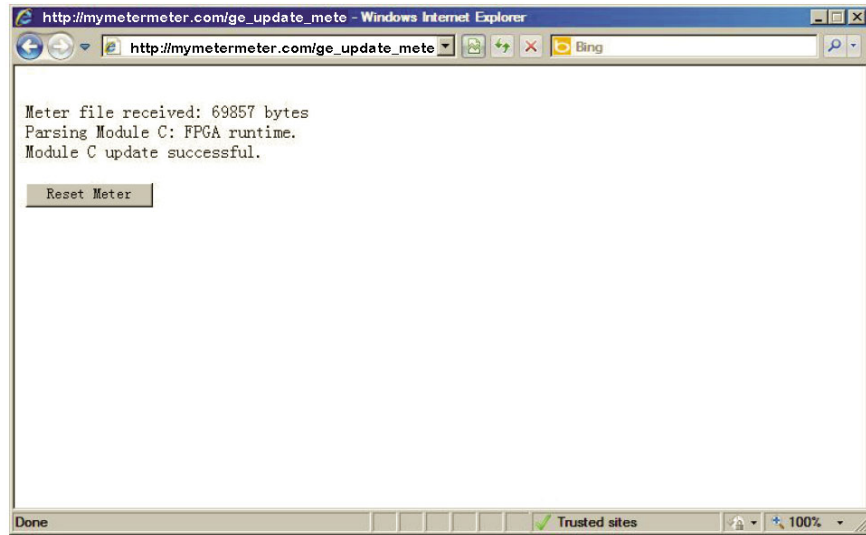

NOTE

You can also upgrade the meter's firmware using GE Communicator software. Refer to the *GE Communicator Instruction Manual* for instructions.



NOTE

See Appendix B for details on the IEC-61850 SCL Upgrade option.



NOTE

The Tools Webpage also gives you the option of updating the IEC 61850 SCL file of a meter with the IEC 61850 Protocol Server, and the Energy Presets of a meter. Click on the option you want - you will be prompted to enter password information and then to select the update file.

Multilin™ EPM 9900P

Chapter 10: EN 50160/IEC 61000-4-30 Class A Reporting

10.1 Overview

The EPM 9900P meter can record power quality reporting values in two independent logs. When EN 50160/IEC 61000-4-30 reporting is enabled, entries are made into the logs when the associated values occur. All values can be downloaded to the Log Viewer where they are available for graphing or export to another program, such as a spreadsheet. The EPM 9900P meter also lets you customize the EN 50160/ IEC 61000-4-30 reporting so that the user can meet specific jurisdictional or regional requirements.



Since the EN 50160/IEC 61000-4-30 reporting has specific requirements for programming, GE VERNOVA recommends that you refer to the IEC 61000-4-30 2008 standard before making changes to the default settings of the meter.

10.2 Flicker Measurement

Flicker is one of the important power quality values that the meter can record. Flicker is the sensation experienced by the human visual system when it is subjected to changes occurring in the illumination intensity of light sources. The primary effects of flicker are headaches, irritability and, sometimes, epileptic seizures. Flicker can be caused by voltage variations that are in turn caused by variable loads, such as arc furnaces, laser printers and microwave ovens.

IEC 61000-4-15 and former IEC 868 describe the methods used to determine flicker severity. This phenomenon is strictly related to the sensitivity and the reaction of individuals. It can only be studied on a statistical basis by setting up suitable experiments among people.



The meter is calculating its Flicker measurement based upon the EN 61000-4-15 standard which is referenced in the EN 61000-4-30 standard. The accuracy requirements for this instrument are within the Class A standards for Flicker measurements.

10.2.1 Theory of Operation

In order to model the eye brain change, which is a complex physiological process, the signal from the power network has to be processed while conforming with Figure 10-1.

- Block 1 consists of scaling circuitry and an automatic gain control function that normalizes input Voltages to Blocks 2, 3 and 4.
- Block 2 recovers the Voltage fluctuation by squaring the input voltage scaled to the reference level. This simulates the behavior of a lamp.
- Block 3 is composed of a cascade of two filters and a measuring range selector. In this implementation, a log classifier covers the full scale in use so the gain selection is automatic and not shown here. The first filter eliminates the DC component and the double mains frequency components of the demodulated output. For 50 Hz operation, the configuration consists of a first-order high pass filter with 3db cut-off frequency at about 0.05 Hz and a 6-order butterworth low pass filter with 35 Hz 3 db cut-off frequency. The second filter is a weighting filter that simulates the response of the human visual system to sinusoidal Voltage fluctuations of a coiled filament, gas-filled lamp (60 W - 230 V). The filter implementation of this function is as specified in IEC 61000-4-15.
- Block 4 is composed of a squaring multiplier and a Low Pass filter. The human flicker sensation via lamp, eye and brain is simulated by the combined non-linear response of Blocks 2, 3 and 4.
- Block 5 performs an online statistical cumulative probability analysis of the flicker level. Block 5 allows direct calculation of the evaluation parameters Pst and Plt.

Flicker evaluation occurs in the following forms: Instantaneous, Short Term or Long Term. Each form is detailed below:

Instantaneous Flicker Evaluation

An output of 1.00 from Block 4 corresponds to the reference human flicker perceptibility threshold for 50% of the population. This value is measured in perceptibility units (PU) and is labeled Pinst. This is a real time value that is continuously updated.

Short Term Flicker Evaluation

An output of 1.00 from Block 5 (corresponding to the Pst value) corresponds to the conventional threshold of irritability per IEC 61000-3-3:2008 edition 2 and EN61000-3-3:2008. In order to evaluate flicker severity, two parameters have been defined: one for the short term called Pst (defined in this section) and one for the long term called Plt (defined in the next section).

The standard measurement time for Pst is 10 minutes. Pst is derived from the time at level statistics obtained from the level classifier in Block 5 of the flicker meter. The following formula is used:

$$P_{st} = \sqrt{0.0314P_{0.1} + 0.0525P_{1s} + 0.0657P_{3s} + 0.28P_{10s} + 0.08P_{50s}} \quad (\text{EQ 10.1})$$

where the percentiles P(0.1), P(1), P(3), P(10), P(50) are the flicker levels exceeded for 0.1, 1, 2, 20 and 50% of the time during the observation period. The suffix S in the formula indicates that the smoothed value should be used. The smoothed values are obtained using the following formulas:

$$P(1s) = (P(.7) + P(1) + P(1.5))/3$$

$$P(3s) = (P(2.2) + P(3) + P(4))/3$$

$$P(10s) = (P(6) + P(8) + P(10) + P(13) + P(17))/5$$

$$P(50s) = (P(30) + P(50) + P(80))/3$$

The 0.3-second memory time constant in the flicker meter ensures that P(0.1) cannot change abruptly and no smoothing is needed for this percentile.

Long Term Flicker Evaluation

The 10-minute period on which the short-term flicker severity is based is suitable for short duty cycle disturbances. For flicker sources with long and variable duty cycles (e.g., arc furnaces) it is necessary to provide criteria for long-term assessment. For this purpose, the long-term Plt is derived from the short-term values over an appropriate period. By definition, this is 12 short-term values of 10 minutes each over a period of 2 hours. The following formula is used:

$$P_{lt} = \sqrt[3]{\frac{\sum_{i=1}^N P_{sti}^3}{N}} \quad (\text{EQ 10.2})$$

where Psti (i = 1, 2, 3...) are consecutive readings of the short-term severity Pst.

10.2.2 Summary

Flicker = changes in the illumination of light sources due to cyclical voltage variations

Pinst = instantaneous flicker values in perceptibility units (PU)

Pst = value based on 10-minute analysis

Plt = value based on 12 Pst values

Measurement Procedure

1. Original signal with amplitude variations
2. Square demodulator
3. Weighted filter
4. Low pass filter 1st order
5. Statistical computing

Data available

- Pst, Pst Max, Pst Min values for long term recording
- Plt, Plt Max, Plt Min values for long term recording

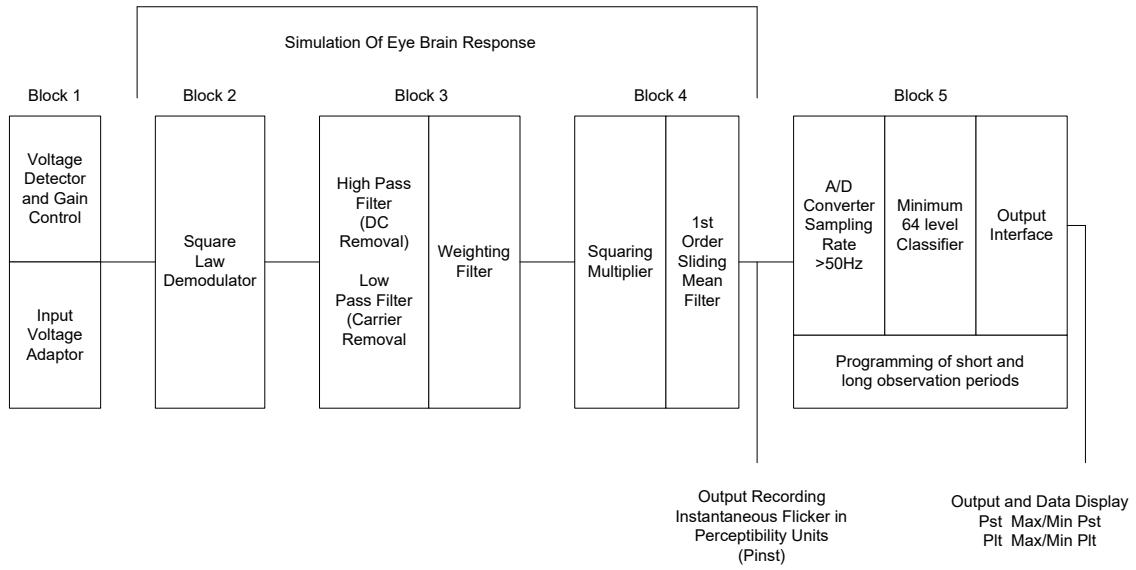

Figure 10-1: Simulation of Eye Brain Response

10.3 EN50160/IEC61000-4-30 Settings

The EPM 9900P meter also lets you customize the EN 50160/IEC 61000-4-30 reporting to meet specific jurisdictional or regional requirements. Refer to the *GE Communicator Instruction Manual* for instructions on setting up reporting, and additional information, including viewing and printing the EN 50160/IEC 61000-4-30 data.

Multilin™ EPM 9900P

Chapter 11: Using the I/O Options

11.1 Overview

The EPM 9900P meter offers extensive I/O expandability. With its four Option card slots, you can easily configure the meter to accept new I/O Option cards without removing it from its installation. The EPM 9900P meter auto-detects any installed Option cards. The meter also offers multiple optional external I/O modules.

11.2 Installing Option Cards

The Option cards are inserted into their associated Option card slots in the back of the EPM 9900P meter.

CAUTION

IMPORTANT! Remove Voltage inputs and power supply to the meter before performing card installation.

Figure 11-1: Inserting an I/O Card into the Meter

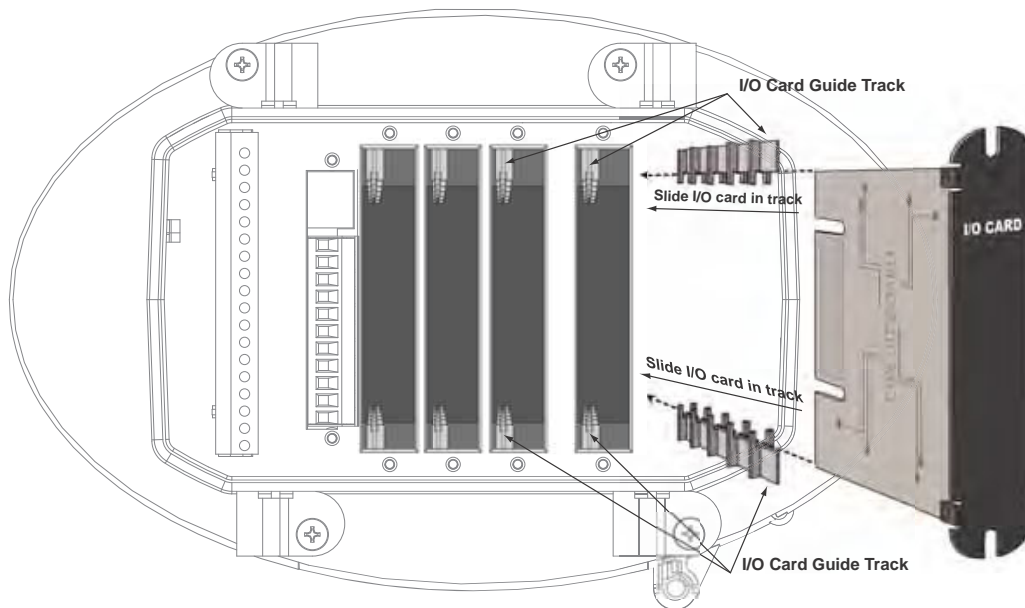

1. Remove the screws at the top and the bottom of the Option card slot covers.
2. There is a plastic "track" on the top and the bottom of the slot. The Option card fits into this track.

NOTICE

Make sure the I/O card is inserted properly into the track to avoid damaging the card's components.

3. Slide the card inside the plastic track and insert it into the slot. You will hear a click when the card is fully inserted. **Be careful:** it is easy to miss the guide track. Refer to Figure 11-1.

11.3 Configuring Option Cards

CAUTION

FOR PROPER OPERATION, RESET ALL PARAMETERS IN THE UNIT AFTER HARDWARE MODIFICATION.

The EPM 9900P meter auto-detects any Option cards installed in it. Configure the Option cards through GE Communicator software. Refer to the *GE Communicator Instruction Manual* for detailed instructions.

11.4 Pulse Output/RS485 Option Card (S Option)

The Pulse Output/RS485 option card gives the meter 4 KYZ outputs that can be used for counting operations, such as counting pulses from a gas or water meter to accumulate usage; and also gives the meter an RS485 Modbus communication port.

Pulse Output/RS485 Port Specifications

Dual RS485 Transceiver; meets or exceeds EIA/TIA-485 Standard	
Type:	Two-wire, half duplex
Min. Input Impedance:	96 k Ω
Max. Output Current:	± 60 mA
Isolation Between Channels	AC 1500 V

Wh Pulse

4 KYZ output contacts	
Pulse Width:	Programmable from 5 msec to 635 msec
Full Scale Frequency:	100 Hz
Form:	Selectable from Form A or Form C
Contact type:	Solid State - SPDT (NO - C - NC)
Relay type:	Solid state
Peak switching voltage:	DC ± 350 V
Continuous load current:	120 mA
Peak load current:	350 mA for 10 ms
On resistance, max.:	35 Ω
Leakage current:	1 μ A@350 V
Isolation:	AC 2500 V
Reset State:	(NC - C) Closed; (NO - C) Open

General Specifications for Pulse Output/RS485 Board

Operating Temperature:	(-20 to +70) $^{\circ}$ C
Storage Temperature:	(-30 to +80) $^{\circ}$ C
Relative Air Humidity:	Maximum 95%, non-condensing
EMC - Immunity Interference:	EN61000-4-2
Weight:	2.4 oz
Dimensions (inches) W x H x L:	0.75" x 4.02" x 4.98"
I/O Card slot:	Option slot 1
External Connection:	Wire range: 16 to 26 AWG Strip Length: 0.250" Torque: 2.2 lb-in 18 pin, 3.5 mm pluggable terminal block

11.4.1 Pulse Output/RS485 Option Card (S Option) Wiring

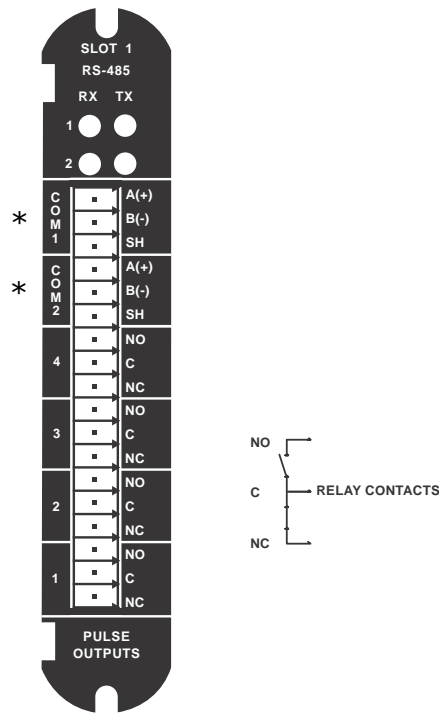

* **NOTE:** Refer to Chapter 5 *Communication Wiring* for RS485 setting instructions.

11.5 Ethernet Option Card: RJ45 (E1) or Fiber Optic (E2)

The Ethernet Option card provides data generated by the meter via Modbus, offering up to 32 sockets TCP/IP. It offers a second Ethernet port for the meter, which can be controlled independently, and which can alternatively be configured for IEC 61850 and GOOSE messaging (only one of the Ethernet cards can support IEC 61850 at one time). It also offers router functions which let the user decide open and closed ports and protocols to meet specific secure applications. It can be factory configured as a 10/100BaseT or as a 100Base-FX Fiber Optic communication port. An example use of the optional Fiber Optic card is in a daisy chain topology, using the Echo switch on the Fiber Optic Card to allow messages to bypass the unit.



Refer to the *GE Communicator Instruction Manual* for instructions on performing Network configuration. See Chapter 9 *EPM 9900P Network Communications* for details on configuring the standard main Network card.

The technical specifications at 25 °C are as follows

Number of Ports:	1
Operating rate:	10/100Mbit
Diagnostic feature:	Status LEDs for LINK and ACTIVE
Number of simultaneous Modbus connections:	32 (Includes 32 total connections over both Ethernet connections.)
Number of simultaneous DNP connections:	2 TCP and 1 UDP per communication channel

The general specifications are as follows

Operating Modes:	10/100BaseT or 100Base-FX
Operating Temperature:	(-20 to +70) °C
Storage Temperature:	(-30 to +80) °C
Relative air humidity:	Maximum 95%, non-condensing
EMC - Immunity Interference:	EN61000-4-2
Weight:	2.3 oz
Dimensions (inches) W x H x L:	0.75" x 4.02" x 5.49"
I/O Card slot:	Option slot 2
Connection Type:	RJ45 modular (Auto-detecting transmit and receive) 10/100BaseT OR Duplex ST Receptacle - 100Base-FX

Fiber Optic Specifications are as follows

Connector:	ST
Fiber Mode:	Multimode Fiber 62.5/125 um
Wavelength:	1310 nm
Max. Distance:	2 km

Default Configuration

The EPM 9900P meter automatically recognizes the installed Option card during power-up. If you have not programmed a configuration for the Ethernet card, the unit defaults to the following configuration:

IP Address: 10.0.0.1

Subnet Mask: 255.255.255.0

Default Gateway: 0.0.0.0



NOTE

The IP addresses of the EPM 9900P meter's standard main Network card and optional Network Card 2 must be in different subnets.

11.6 Relay Output Option Card (R1)

The Relay Output option card is used to send a control output (electrical signal) when a limit is exceeded, for example to turn on a breaker or sound an alarm. The card has 6 relay contact outputs for load switching. The outputs are electrically isolated from the main unit.

Accumulators in the GE Communicator software count the transitions of the outputs. When installing a Relay Output option card, we recommend you reset the accumulators for the card, in order to prevent erroneous counts. See the *GE Communicator Instruction Manual* for instructions on resetting the output accumulators.

The technical specifications at 25 °C are as follows

Power consumption:	0.320 W internal
Relay outputs:	
Number of outputs:	6
Contact type:	Changeover (SPDT)
Relay type:	Mechanically latching
Switching voltage:	AC 250 V / DC 30 V
Switching power:	1250 VA / 150 W
Switching current:	5 A
Switching rate max:	10/s
Mechanical life:	5 x 10 ⁷ switching operations
Electrical life:	10 ⁵ switching operations at rated current
Breakdown voltage:	AC 1000 V between open contacts
Isolation:	AC 2500 V surge system to contacts
Reset/Power down state:	No change - last state is retained

The general specifications are as follows

Operating temperature:	(-20 to +70) °C
Storage temperature:	(-30 to +80) °C
Relative air humidity:	Maximum 95%, non-condensing
EMC - Immunity Interference:	EN61000-4-2
Weight:	2.7 oz
Dimensions (inches) W x H x L:	0.75" x 4.02" x 4.98"
I/O Card slot:	Option slots 3 and 4
External connection:	Wire range: 16 to 26 AWG Strip length: 0.250" Torque: 2.2 lb-in 18 pin, 3.5 mm pluggable terminal block

11.6.1 Relay Output Option Card (R1) Wiring

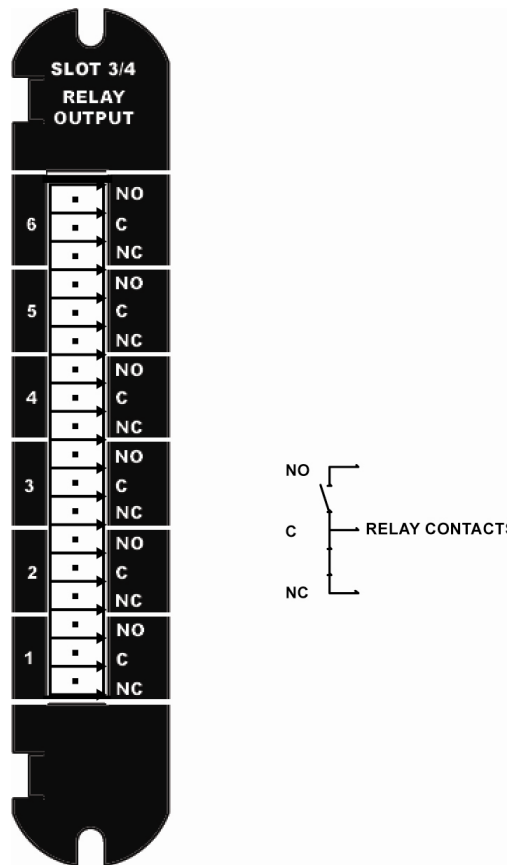

11.7 Digital Input Option Card (D1)

The Digital Input Option card offers 16 wet/dry contact sensing digital inputs. The inputs can be used to either count KYZ pulse or detect the status of a circuit.

Accumulators in the GE Communicator software count the transitions of the inputs. When installing a Digital Input option card, we recommend you reset the accumulators for the card, in order to prevent erroneous counts. See the *GE Communicator Instruction Manual* for instructions on resetting the input accumulators.

The technical specifications at 25 °C are as follows

Power consumption:	0.610 W
Number of inputs:	16
Sensing type:	Wet or dry contact status detection
Wetting voltage:	DC (12-24) V, internally generated
Input current:	1.25 mA - constant current regulated
Minimum input voltage:	0 V (input shorted to V-)
Maximum input voltage:	DC 150 V (diode protected against polarity reversal)

Filtering:	De-bouncing with 10 ms delay time
Detection scan rate:	20 ms
Isolation:	AC 2500 V system to inputs

The general specifications are as follows

Operating temperature:	(-20 to +70) °C
Storage temperature:	(-30 to +80) °C
Relative air humidity:	Maximum 95%, non-condensing
EMC - Immunity Interference:	EN61000-4-2
Weight:	2.4 oz
Dimensions (inches) W x H x L:	0.75" x 4.02" x 4.98"
I/O Card slot:	Option slots 3 and 4
External connection:	Wire range: 16 to 26 AWG Strip length: 0.250" Torque: 2.2 lb-in 18 pin, 3.5 mm pluggable terminal block



This feature allows for either status detect or pulse counting. Each input can be assigned an independent label and pulse value.

11.7.1 Digital Input Option Card (D1) Wiring

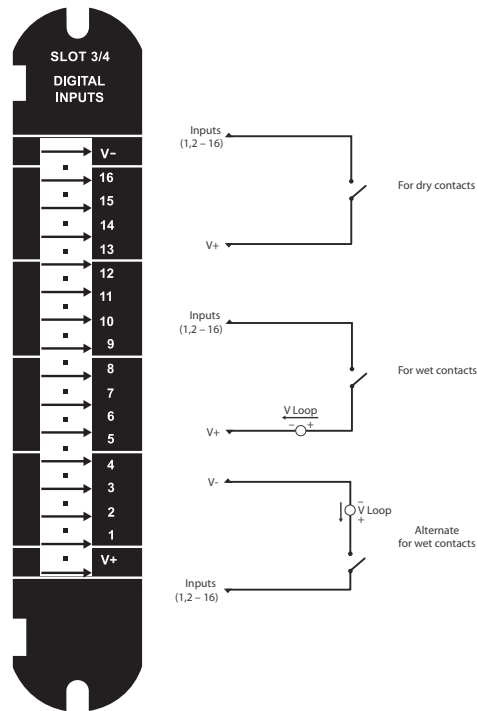

11.8 Optional External I/O Modules

In addition to the Option cards previously explained, the EPM 9900P meter offers external I/O modules. The meter acts as a master to any external I/O modules or Option cards. All EPM 9900P external I/O modules have the following components:

- Female RS485 Side Port: use to connect to another module's male RS485 side port.
- Male RS485 Side Port: use to connect to the EPM 9900P meter's Port 3 or 4 or to another module's female RS485 side port. See Figure 11-2 for wiring details.
- I/O Port: used for functions specific to the type of module. Size and pin configuration vary depending on the type of module.
- Reset Button: press and hold for three seconds to reset the module's baud rate to 57600, and its address to 247 for 30 seconds.
- LEDs: when flashing, the LEDs signal that the module is functioning.
- Mounting Brackets (MBO): used to secure one or more modules to a flat surface. Comes with 2 DIN rail mounting clips.

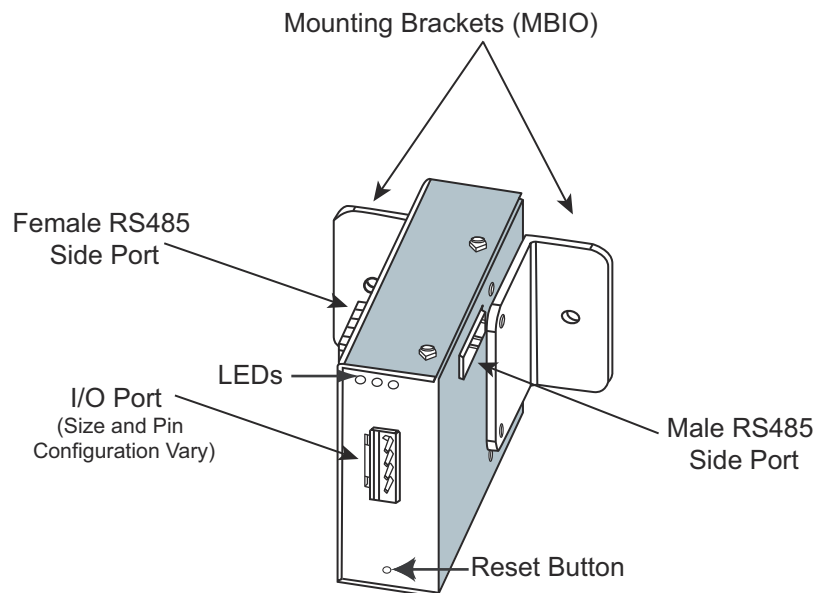
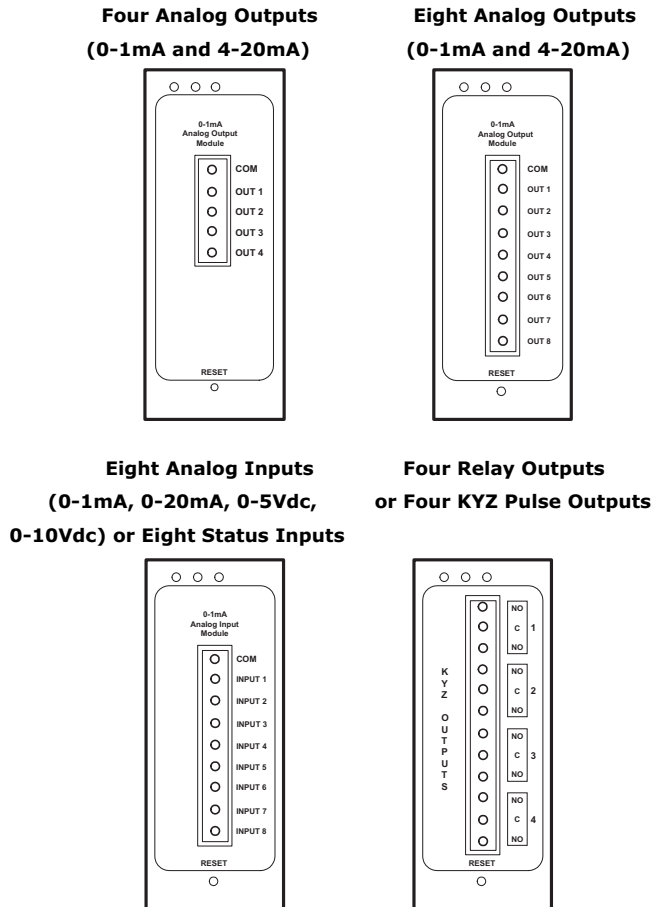

Figure 11-2: I/O Module Components

11.8.1 Port Overview

All of the optional external I/O modules have ports through which they interface with other devices. The port configurations are variations of the four types shown below.

Figure 11-3: External I/O Module Ports



11.8.2 Installing Optional External I/O Modules

I/O modules must use the EPM 9900P meter's ports 3 or 4. Six feet of RS485 cable harness is supplied. Attach one end of the cable to the port (connectors may not be supplied); insert the other end into the communication pins of the module's male RS485 side port (see Figure 11-2). See *Steps for Attaching Multiple I/O Modules* in section 11.8.4 for details on using multiple I/O modules.

Installing the External I/O Modules

1. Connect the (+) and (-) terminals on the EPM 9900P meter to the (+) and (-) terminals of the male RS485 port.
2. Connect the shield to the shield (S) terminal. The (S) terminal on the EPM 9900P meter is used to reference the EPM 9900P meter's port to the same potential as the source. It is not an earth to ground connection. You must also connect the shield to earth-ground at one point.

3. Put termination resistors at each end, connected to the (+) and (-) lines. RT is ~120 Ohms.
4. Connect a power source to the front of the module.

11.8.3 Power Source for External I/O Modules

The EPM 9900P meter does not have internal power for the external I/O modules. You must use a power supply, such as the GE Grid Solutions PSIO, to power any external I/O modules.

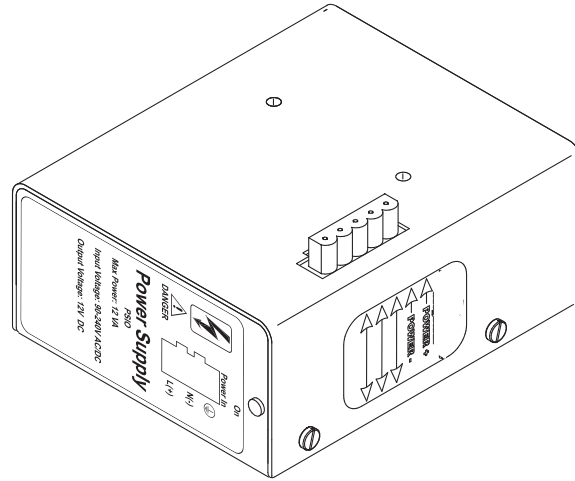

Figure 11-4: PSIO Side View

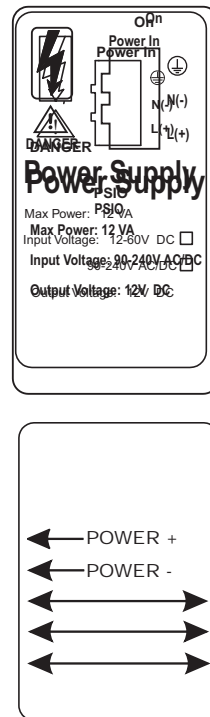

Figure 11-5: PSIO Side and Top Labels

11.8.4 Using PSIO with Multiple I/O Modules



PSIO must be to the right of the I/O modules, when viewing its side label (as shown in the figure below).

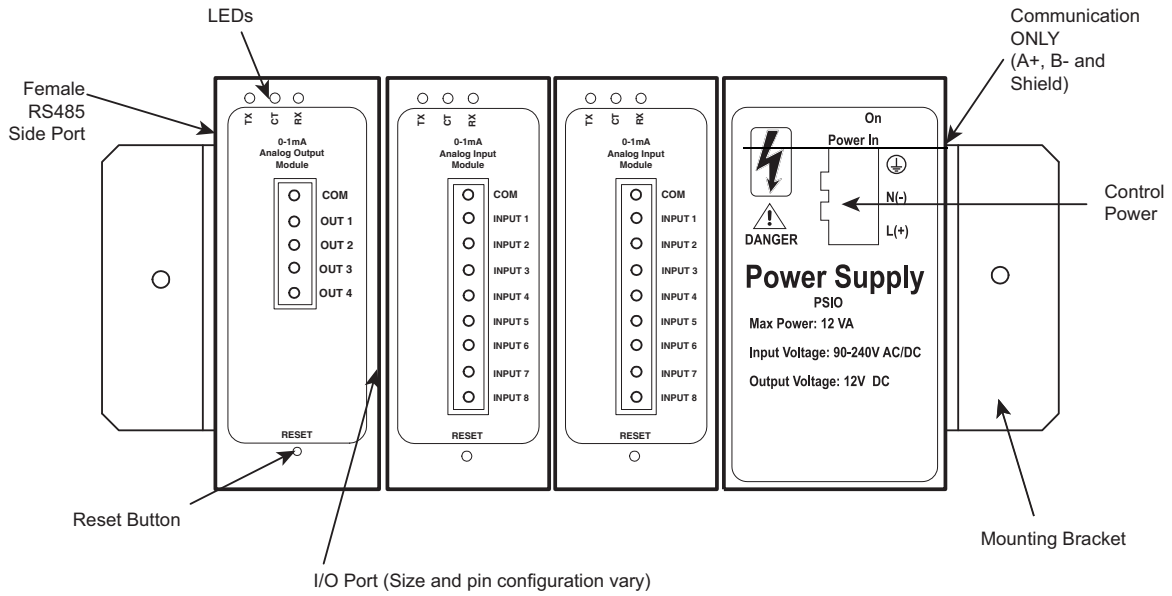

Figure 11-6: PSIO with Multiple External I/O Modules

Steps for Attaching Multiple I/O Modules

I/O Module Dimensions

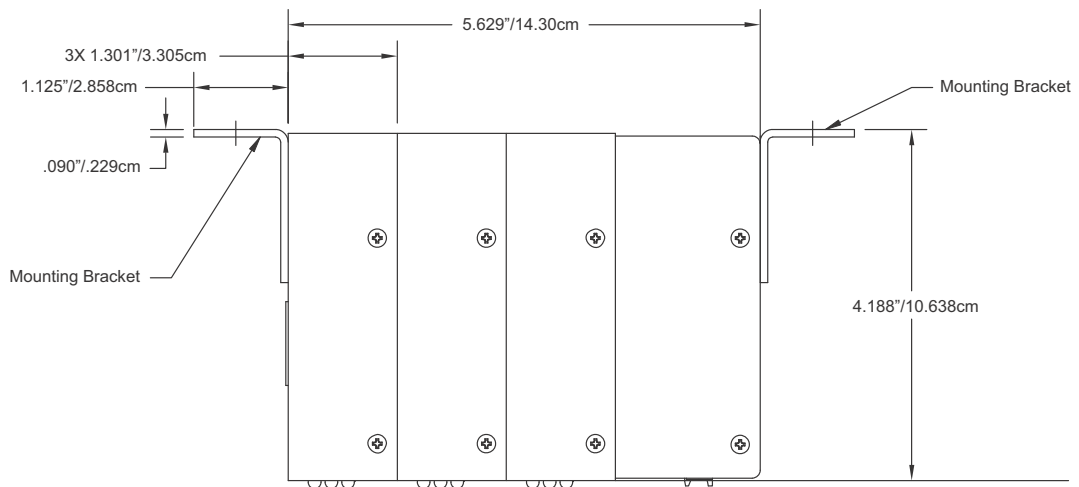

Figure 11-7: I/O Modules, Top View

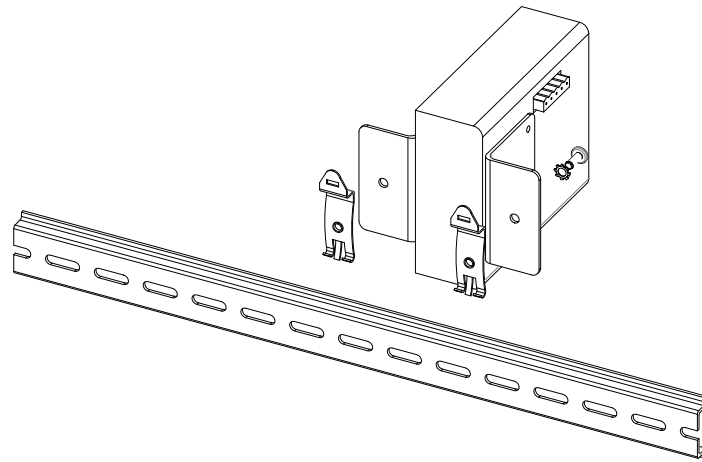

Figure 11-9: Mounting the Brackets on a DIN Rail

To use the DIN rail mounting clips:

A - From the front of either bracket, insert the screw into the lock washer and through the hole, and screw it into the clip using an appropriate screwdriver. Note that the clip should be positioned as shown above, with the indented side facing the back.

B - Repeat step A for the second bracket.

C - Hook the bottom of the clips around the bottom of the DIN rail and then push the top of the clips forward so that they fit over the top of the DIN rail. See the figure below.

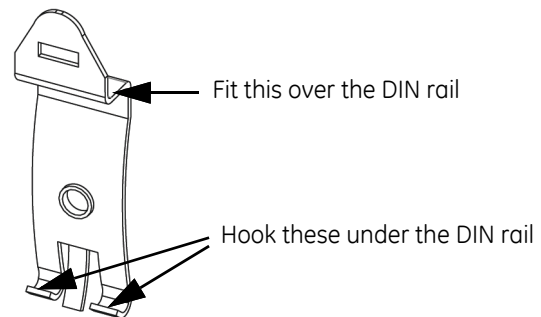

Figure 11-10: Detail of the DIN Rail Mounting Clip

11.8.5 Factory Settings and Reset Button

Factory Settings

All external I/O modules are shipped with a preset address and a baud rate of 57600. See following sections for I/O Module addresses.

Reset Button:

If there is a communication problem or if you are unsure of a module's address and baud rate, press and hold the **Reset** button for 3 seconds; the module resets to a default address of 247 at 57600 baud rate for 30 seconds.

11.8.6 Analog Transducer Signal Output Modules

Analog Transducer Signal Output Module Specifications	
Model Numbers	1mAON4: 4-channel analog output 0±1 mA
	1mAON8: 8-channel analog output 0±1 mA
	20mAON4: 4-channel analog output 4-20 mA
	20mAON8: 8-channel analog output 4-20 mA
Accuracy	0.1% of Full Scale
Over-range	±20% of Full Scale
Scaling	Programmable
Communication	RS485, Modbus RTU
	Programmable Baud Rates: 4800, 9600, 19200, 38400, 57600
Power Requirement	12-20 VDC @50-200 mA
Operating Temperature	(-20 to +70) °C/(-4 to +158) °F
Maximum Load Impedance	0±1mA: 10k Ohms; 4 to 20mA: 500 Ohms
Factory Settings	Modbus Address: 1mAON4: 128; 1mAON8: 128; 20mAON4: 132; 20mAON8: 132
	Baud Rate: 57600
	Transmit Delay Time: 0
Default Settings (Reset Button)	Modbus Address: 247
	Baud Rate: 57600
	Transmit Delay Time: 20 msec

Overview

The Analog Transducer Signal Output module is used to convert digital values from the meter into a variable voltage level presented on the output terminal to be used with analog devices, such as Programmable Logic Controllers (PLCs).

The Analog Transducer Signal Output modules (0±1 mA or 4 to 20 mA) are available in either a 4-channel or 8-channel configuration. Maximum registers per request, read or write, is 17 registers.

All outputs share a single common point. This is also an isolated connection (from ground).

Normal Mode

Normal mode is the same for the 0 to 1 mA and the 4 to 20 mA Analog Output modules except for the number of processes performed by the modules.

Both devices:

1. Accept new values through communication
2. Output current loops scaled from previously accepted values

The 0 to 1 mA module includes one more process in its Normal mode:

3. Reads and averages the A/D and adjust values for Process 2, above

The device operates with the following default parameters:

Address: 247 (F7H)

Baud Rate: 57600 Baud

Transmit Delay Time: 20 msec

11.8.7 Digital Dry Contact Relay Output (Form C) Module



Only one of these modules may be connected to an EPM 9900P meter.

The Digital Dry Contact Relay Output module is used to send a control output (electrical signal) when a limit is exceeded, for example to turn on a breaker or sound an alarm.

Digital Dry Contact Relay Output Module Specifications	
Model Number	4RO1: 4 matching relay outputs
Contact Type	Changeover (SPDT)
Relay Type	Mechanically latching
Communication	RS485, Modbus RTU Programmable Baud Rates: 4800, 9600, 19200, 38400, 57600
Power Requirement	12-20VDC @50 to 200 mA; EPM 9900P supports only one module
Operating Temperature	(-20 to +70) °C / (-4 to +158) °F
Switching Voltage	AC 250 V / DC 30 V
Switching Power	1250 VA / 150 W
Switching Current	5 A
Switching Rate Max.	10/s
Mechanical Life	5 x 10 ⁷ switching operations
Electrical Life	10 ⁵ switching operations at rated current
Breakdown Voltage	AC 1000 V between open contacts
Isolation	AC 2500 V surge system to contacts
Reset/Power Down State	No change - last state is retained
Factory Settings	Modbus Address: 156 Baud Rate: 57600 Transmit Delay Time: 0
Default Settings (Reset Button)	Modbus Address: 247 Baud Rate: 57600 Transmit Delay Time: 20 msec

Overview

The Relay Output module consists of four latching relay outputs. In Normal mode, the device accepts commands to control the relays. Relay Output modules are triggered by limits programmed with the GE Communicator software. See the *GE Communicator Instruction Manual* for details on programming limits.

Each latching relay will hold its state in the event of a power loss.

Communication

Maximum registers per request, read or write, is 4 registers.

The device operates with the following default parameters:

Address: 247 (F7H)

Baud Rate: 57600 Baud

Transmit Delay Time: 20 msec

Normal Mode

Normal mode consists of one process: the device accepts new commands to control the relays.

11.8.8 Digital Solid State Pulse Output (KYZ) Module

Digital Solid State Pulse Output Module Specifications	
Model Number	4PO1
Communication	RS485, Modbus RTU
	Programmable Baud Rates: 4800, 9600, 19200, 38400, 57600
Power Requirement	15-20 VDC @50-200 mA
Operating Temperature	(-20 to +70) °C/(-4 to +158) °F
Voltage Rating	Up to 300 VDC
Commands Accepted	Read and Write with at least 4 registers of data per command
Memory	256 Byte IC EEPROM for storage of programmable settings and non-volatile memory
Factory Settings	Modbus Address: 160
	Baud Rate: 57600
	Transmit Delay Time: 0
Default Settings (Reset Button)	Modbus Address: 247
	Baud Rate: 57600
	Transmit Delay Time: 20 msec

Overview

The KYZ Pulse Output modules have 4 KYZ pulse outputs and accept Read and Write commands with at least 4 registers of data per command. Digital Solid State Pulse Output (KYZ) modules are user programmed to reflect VAR-hours, WATT-hours, or VA-hours. An example use of the Pulse Output/Digital Input Card is in a sub-metering application where a pulse output is needed.

NC = Normally Closed; NO = Normally Open; C = Common.

Communication

Maximum registers per request, read or write, is 4 registers.

The device operates with the following default parameters:

Address: 247 (F7H)

Baud Rate: 57600 Baud

Transmit Delay Time: 20 msec

Normal Mode

Energy readings are given to the device frequently. The device generates a pulse at each channel after a certain energy increase.

Normal operation consists of three processes:

1. The first process accepts writes to registers 04097 to 04112. Writes can be up to four registers long and should end on the fourth register of a group (register 04100, or registers 04103 to 04112 or registers 04109 to 04112). These writes can be interpreted as two-byte, four-byte, six-byte or eight-byte energy readings. The reception of the first value for a given channel provides the initial value for that channel. Subsequent writes will increment the residual for that channel by the difference of the old value and the new value. The previous value is then replaced with the new value. Attempting to write a value greater than the programmed rollover value for a given channel is completely ignored and no registers are modified. If the difference is greater than half of the programmed rollover value for a given channel, the write does not increment the residual but does update the last value. Overflow of the residual is not prevented.
2. The second process occurs in the main loop and attempts to decrement the residual by the programmed Energy/Pulse value. If the residual is greater than the programmed Energy/Pulse value and the Pending Pulses value for that channel has not reached the maximum limit, then residual is decremented appropriately and the Pending Pulses value is incremented by two, signifying two more transitions and one more pulse.
3. The third process runs from a timer that counts off pulse widths from the Programmable Minimum Pulse Width values. If there are pulses pending for a channel and the delay has passed, then the Pending Pulses value is decremented for that channel and the output relay is toggled.

Operation Indicator (0000H = OK, 1000H = Problem):

Bit 1: 1 = EEPROM Failure

Bit 2: 1 = Checksum for Communications settings bad

Bit 3: 1 = Checksum for Programmable settings bad

Bit 4: 1 = 1 or more Communications settings are invalid

Bit 5: 1 = 1 or more Programmable settings are invalid

Bit 6: 1 = 1 or more Programmable settings have been modified

Bit 7: 1 = Forced default by reset value

Bit 15: 1 = Normal operation of the device is disabled

11.8.9 Analog Input Modules



Up to four of these modules may be connected to an EPM 9900P meter.

Analog Input Module Specifications	
Model Numbers	8AI1: 8-channel analog input 0±1 mA
	8AI2: 8-channel analog input 0±20 mA
	8AI3: 8-channel analog input 0±5 VDC
	8AI4: 8-channel analog input 0±10 VDC
Accuracy	0.25% of Full Scale
Scaling	Programmable
Communication	RS485, Modbus RTU
	Programmable Baud Rates: 4800, 9600, 19200, 38400, 57600
Power Requirement	15-20 VDC @50-200 mA
Operating Temperature	(-20 to +70) °C/(-4 to +158) °F
Maximum Load Impedance	0±1 mA: 10 k Ohms; 4-20 mA: 500 Ohms
Factory Settings	Modbus Address: 8AI1: 136; 8AI2: 140; 8AI3: 144; 8AI4: 148
	Baud Rate: 57600
	Transmit Delay Time: 0
Default Settings (Reset Button)	Modbus Address: 247
	Baud Rate: 57600
	Transmit Delay Time: 20 msec

Overview

The Analog Input Modules (0±1 mA, 0±20 mA, 0±5 VDC and 0±10 VDC) are available in an 8-channel format. Maximum registers per request, read or write, is 17 registers.

All inputs share a single common point. This is also an isolated connection (from ground).

Normal Mode

In Normal Mode, the Input Module:

1. Reads and averages the A/D and adjusts values for process 2.
2. Calculates the percentage of Input Value.



The percentage value of the Input is stored in Input Value Registers (Registers 04097 to 04104).

The device operates with the following default parameters:

Address: 247 (F7H)

Baud Rate: 57600 Baud

Transmit Delay Time: 20 msec

11.9 Additional External I/O Module Specifications

Analog Transducer Signal Outputs (Up to four modules can be used.)

1mAON4: 4 Analog Outputs, scalable, bidirectional

1mAON8: 8 Analog Outputs, scalable, bidirectional

20mAON4: 4 Analog Outputs, scalable

20mAON8: 8 Analog Outputs, scalable

Digital Dry Contact Relay Outputs (One module can be used.)

4RO1: 4 Relay Outputs 10 Amps, 125 VAC, 30 VDC, Form C

Digital Solid State Pulse Outputs (Up to four modules can be used.)

4PO1: 4 Solid State Pulse Outputs, Form A KYZ pulses

Analog Transducer Inputs (Up to four modules can be used.)

- 8AI1: 8 Analog Inputs 0 to 1 mA, scalable and bidirectional
- 8AI2: 8 Analog Inputs 0 to 20 mA, scalable
- 8AI3: 8 Analog Inputs 0 to 5 V DC, scalable
- 8AI4: 8 Analog Inputs 0 to 10 V DC, scalable

Other I/O Module Accessories

MBIO: Bracket for surface-mounting external I/O modules to any enclosure

PSIO: 12 V external power supply, which is necessary whenever you are connecting an external I/O module to a EPM 9900P meter.

Multilin™ EPM 9900P

Chapter 12: Test Mode

12.1 Introduction

The EPM 9900P meter offers a Test Mode that lets you verify the meter's accuracy without affecting billing data. When a meter is put into Test Mode, all of the energy registers are frozen, the display is set to 0, and the user can access the energy measurement test sequences. The meter's accuracy is determined by comparing energy accumulated values provided by it against a well known source also monitored by the meter.

The Energy Preset, or Preset Accumulators, feature supports Test Mode. This feature allows a user to preset the energy accumulators to a desired value. This is important because when a meter is in Test Mode, it is out of service and not monitoring accumulations. You can use the Test Mode Preset Accumulations screens to enter a new value that adjusts for those not monitored while the meter was in Test Mode. You can preset single or multiple accumulators. The new values will take effect after you leave Test Mode. If no preset values are entered, the Normal Mode energy accumulator values will have the same values they had when you entered Test Mode.

This feature is also useful when removing a meter from service and replacing it with a new meter. You can use the Preset Accumulators screen to set the new meter with the accumulation values from the old meter. This way, the new meter can continue to accumulate where the old meter left off.

All Test Mode data can be monitored either:

- Through the meter's display
- By polling the Modbus registers through the meter's communication ports (see the *EPM 9900P Modbus Guide* for detailed information on the Modbus registers)

Some of the Test Mode data (-Wh (Q2,3), +Wh (14), +VARh (Q1,2), -VARh (Q3,4)) can also be measured using the LED pulse outputs (see the following section, 12.1.1).

All Test Mode data is provided in binary secondary units (i.e., W, Wh, VA, VAh, VAR, VARh): no kilo-units or mega-units are used. All Test Mode energy accumulators are formatted as 15 digit integers with 7 decimal digits; Test Mode demand is formatted as 4 digit integers with 4 decimal digits.

The EPM 9900P meter's Test Mode implementation has a security feature which allows you to block Test Mode access for one or both of the Ethernet ports, if necessary.

12.1.1 LED Pulse Outputs and Test Mode

The EPM 9900P meter provides 2 LED pulse outputs (KYZ outputs 1 and 2), which in Normal Mode can be enabled and programmed to send a light pulse with a certain width every time a certain amount of a energy has been accumulated. For Test Mode use, the LEDs are programmed as shown on the following table. The energy source used for each LED constitutes a unique Test Mode operation.

Device Profile Settings						
Test Mode	Mode	Form	Pulse Width (msec)	Factor (Wh per pulse)	Source	
					LED 1	LED 2
1	Always enabled	Pulse (Form A)	100	as programmed in device profile	+Wh Q14	+VARh Q12
2	Always enabled	Pulse (Form A)	100	as programmed in device profile	+Wh Q14	-VARh Q34
3	Always enabled	Pulse (Form A)	100	as programmed in device profile	-Wh Q23	+VARh Q12
4	Always enabled	Pulse (Form A)	100	as programmed in device profile	-Wh Q23	-VARh Q34



NOTES:

- There are four available Test Modes, as shown in the table. The default Test Mode is 1.
- If LED pulse output is disabled in the device profile, factor settings default to 1.8 Wh per pulse (for WYE systems) and 1.2 Wh per pulse (for DELTA systems) for Class 20 units and 0.36 Wh per pulse (for WYE systems) and 0.24 Wh per pulse (for DELTA systems) for Class 2 units.
- No KYZ output can be programmed for End of Interval Pulse.
- No KYZ output can be programmed for Operation Status Output.

12.2 Test Mode Operation

The EPM 9900P meter can enter Test Mode either through software, through the display, or through a communication port via a Modbus command. With any of these methods, before starting Test Mode, you need to select a compensation type for Test Mode. It should be the same as the compensation that has been set up for the meter in the device profile. The choices are:

- Test with No Compensation
- Test with Transformer Loss Compensation

- Test with CT/PT Compensation
- Test with Transformer Loss and CT-PT Compensation

For Test Mode demand, the interval configured in the meter's device profile will be synchronized either when the meter starts Test Mode, when a new Test Mode operation is selected, or when resetting Test Mode data. If the meter has been configured for block window computation through a digital input, the Test Mode block window interval will default to 15 minutes.

12.2.1 Entering Test Mode through GE Communicator Software

To enter Test Mode through software:

1. From the Main screen, click **Tools>Test Mode>Set Test Mode**. The screen shown below opens.

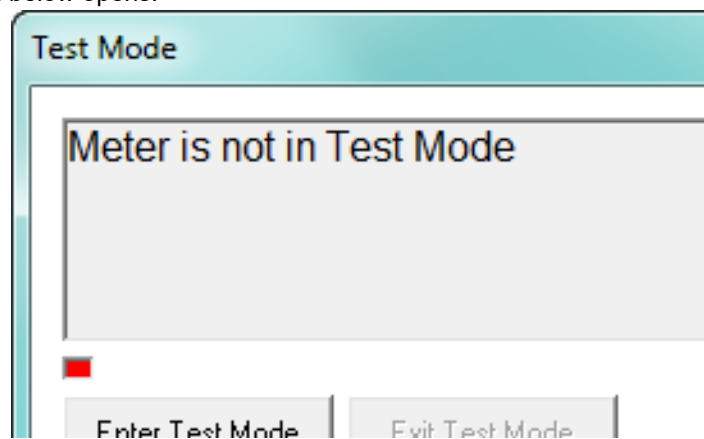

2. Click **Enter Test Mode**. The screen shown below opens.

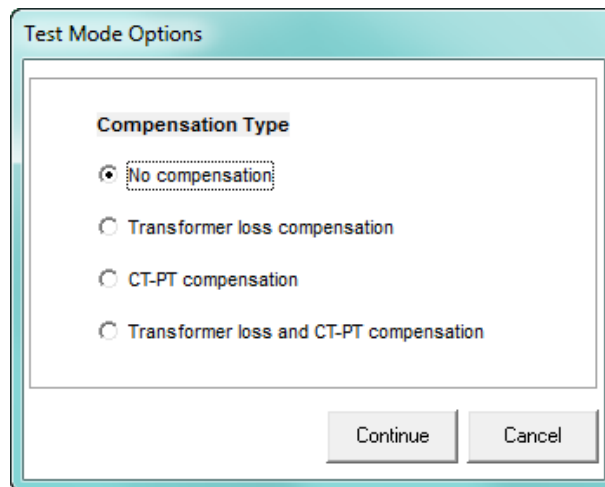

3. Use this screen to select the type of compensation to apply to the Test Mode. You should select the same compensation you are using for the meter (refer to the *GE Communicator Instruction Manual* for instructions on setting the meter's Transformer and CT/PT compensation). Another option would be to test the meter with no compensation at all.

Your choices are:

- No compensation - Test Mode readings will be obtained without any compensation applied.
 - Transformer loss compensation - your setting for Transformer Loss compensation will be applied to the readings in Test Mode.
 - CT-PT compensation - your setting for CT/PT compensation will be applied to the readings in Test Mode.
 - Transformer loss and CT-PT compensation - both your settings for Transformer Loss compensation and CT-PT compensation will be applied to the readings in Test Mode.
4. Click Continue. You will see the Test Mode screen again. You will see a message that Test Mode is starting and then you will see a message that the meter is in Test Mode, with the compensation you selected and the values that are being read, also displayed. See the example screen shown.

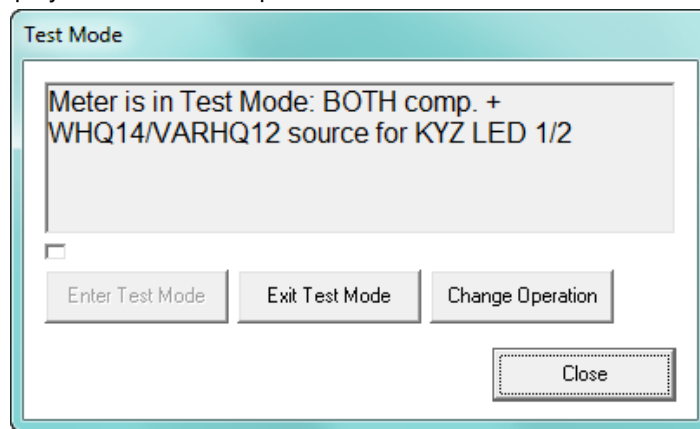

5. WHQ14/VARHQ12 above indicates that the watt-hour readings from quadrants 1 and 4, and the VAR-hour readings from quadrants 1 and 2 are being read in Test Mode. The BOTH comp means that both Transformer loss and CT-PT compensations are being applied. To choose a different energy reading source, click the **Change Operation** button. You will see the screen shown below.

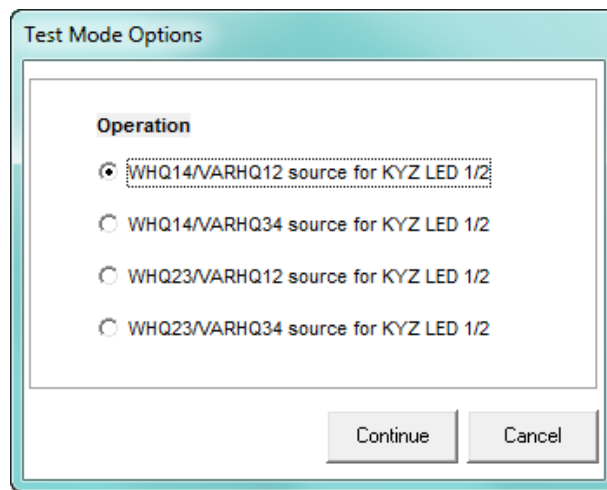

6. The options on this screen are:
- WHQ14/VARHQ12

- WHQ14/VARHQ12
 - WHQ14/VARHQ12
 - WHQ14/VARHQ12
7. Make your selection and click **Continue**. The Test Mode screen is redisplayed, with the current reading source reflecting your selections.

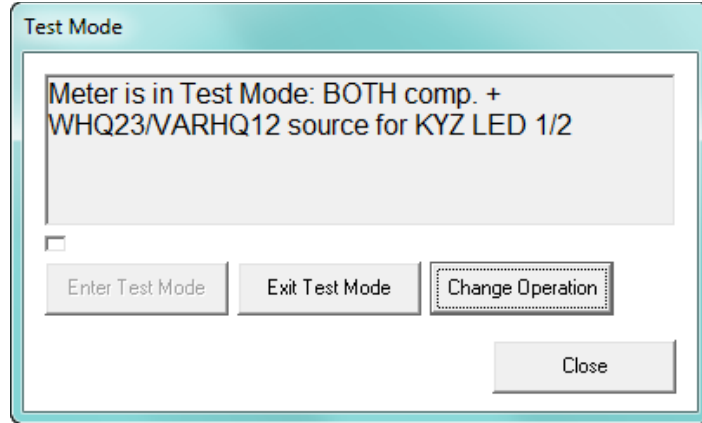

8. If you want to set Energy Presets, click Close to close the Test Mode screen (Test Mode will still be active) and continue to step 9. If you do not want to set Energy Presets, once you are done with Test Mode, click Exit Test Mode. You will see a message that the meter is exiting Test Mode and then Test Mode will stop. Note that the timeout value that you set up in Test Mode Configuration in the meter's Device Profile (see the *GE Communicator Instruction Manual* for instructions on setting the timeout value and more information on Test Mode timeout) will cause the meter to exit Test Mode after a certain amount of time with no activity, even if you do not actively exit Test Mode.

9. Click **Tools>Test Mode>Energy Presets**. You will see the screen shown below.

Item	Current Value	New Value	Preset	Settings
Total VAh(Q1234)	000338.3 k	000338.3 k	<input type="checkbox"/>	999999.9KWh
+VARh (Q12)	000053.6 k	000053.6 k	<input type="checkbox"/>	999999.9KWh
-VARh (Q34)	000150.9 k	000150.9 k	<input type="checkbox"/>	999999.9KWh
+Wh (Q14)	000105.9 k	000105.9 k	<input type="checkbox"/>	999999.9KWh
VAh (Q1)	000114.2 k	000114.2 k	<input type="checkbox"/>	999999.9KWh
VARh (Q1)	000053.5 k	000053.5 k	<input type="checkbox"/>	999999.9KWh
VAh (Q4)	000022.9 k	000022.9 k	<input type="checkbox"/>	999999.9KWh
VARh (Q4)	000001.1 k	000001.1 k	<input type="checkbox"/>	999999.9KWh
-Wh (Q23)	000125.6 k	000125.6 k	<input type="checkbox"/>	999999.9KWh
VAh (Q2)	000010.6 k	000010.6 k	<input type="checkbox"/>	999999.9KWh
VARh (Q2)	000000.1 k	000000.1 k	<input type="checkbox"/>	999999.9KWh
VAh (Q3)	000190.6 k	000190.6 k	<input type="checkbox"/>	999999.9KWh
VARh (Q3)	000149.9 k	000149.9 k	<input type="checkbox"/>	999999.9KWh
Phase A I2T	0000004 k	0000004 k	<input type="checkbox"/>	9999999KWh
Phase B I2T	0000004 k	0000004 k	<input type="checkbox"/>	9999999KWh
Phase C I2T	0000004 k	0000004 k	<input type="checkbox"/>	9999999KWh
Phase A V2T	0010523 k	0010523 k	<input type="checkbox"/>	9999999KWh
Phase B V2T	0010520 k	0010520 k	<input type="checkbox"/>	9999999KWh
Phase C V2T	0010515 k	0010515 k	<input type="checkbox"/>	9999999KWh
Wh (Q1)	000083.5 k	000083.5 k	<input type="checkbox"/>	999999.9KWh
Wh (Q4)	000022.4 k	000022.4 k	<input type="checkbox"/>	999999.9KWh
Wh (Q2)	000010.5 k	000010.5 k	<input type="checkbox"/>	999999.9KWh
Wh (Q3)	000115.0 k	000115.0 k	<input type="checkbox"/>	999999.9KWh
Uncomp Total VAh	000338.4 k	000338.4 k	<input type="checkbox"/>	999999.9KWh
Uncomp VARh(Q12)	000053.7 k	000053.7 k	<input type="checkbox"/>	999999.9KWh
Uncomp VARh(Q34)	000150.9 k	000150.9 k	<input type="checkbox"/>	999999.9KWh

10. The accumulators that can be pre-set are listed on the left of the screen with their current values. You can scroll to see accumulators not displayed.
11. To enter a preset value, click the preset box on the same line with the value and enter the preset value in the New Value field. The Settings field shows the format your entry needs to be in, that is, the number of digits and decimal places; for example, 999999.9KWh.
12. When you have entered all of the preset values you want, click **Set** to send them to the meter's memory. Once the meter is out of Test Mode, these new values will take effect.
13. You can also save the preset values in a .csv file or load preset values that are already saved in a .csv file to this screen:
 - To save the values, click the **Save** button and give the file a name when you are prompted.
 - To load a .csv file, click the **Load** button and locate the file you want to use.
14. When you have finished with the Test Mode Preset screen, click the X in the right corner of the screen to close it.
15. When you want to exit Test Mode, click **Tools>Set Test Mode** to open the Test Mode screen, and then click the **Exit Test Mode** button.

Alternative Methods of Updating Meter with Energy Presets

There are additional ways to update a meter with preset values. When you enter the preset values using the method just described, the values are saved in a file (prstene.bin) which can be used to update the meter in one of the following ways. This is useful if you have multiple meters to update - you can set up the preset values once and then import the file into the other meters.

- Through the meter's webpage: access the meter webpage (http://meter_ip_address) and go to Tools>Energy Preset File Upgrade. Type the password information and browse for the prstene.bin file to update to the meter. See section 20.1.18.1 in the *GE Communicator Instruction Manual* for instructions.
- Through the Modbus holding registers. The file is divided into blocks of 64 bytes each. The current file size for v1 is 1408 bytes, which contains 22 blocks. This method is available to support any customized software application that uses the energy preset values accessed through the Modbus registers. Follow this procedure:
 1. Start to send the file to the meter by writing the first block number (0x0000) to Modbus address 0xAE00.
 2. Write the block to Modbus register 0xAE01-0xAE20.
 3. If all blocks have been written, then go to step e; otherwise continue to step d.
 4. Continue to send the file to the meter by writing the next block number to Modbus address 0xAE00. When finished writing the blocks, proceed to step e.
 5. Compute the CRC-16 checksum for the entire file and write it to the Modbus address 0xAE21
 6. After the checksum is written, the meter will compute the checksum for all blocks received and compare it with the value written into the Modbus register 0xAE21. If they match and the received block has the format described above, then the meter will save the file into the compact flash.



Note that access to the Energy Presets can be password restricted for security (see the *GE Communicator Instruction Manual* for instructions).

12.2.2 Entering Test Mode through the Display

1. To avoid a user accidentally entering Test Mode, the Test Mode button on the display is hidden until you perform the following actions:

- While on a Dynamic screen, press the Backlight button on the front panel for 2 seconds.

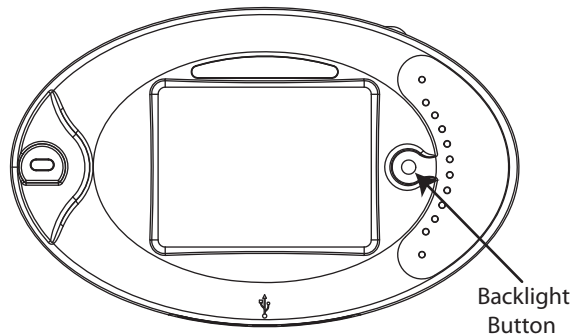

- Then, within 5 seconds, press the i button on the Dynamic screen.

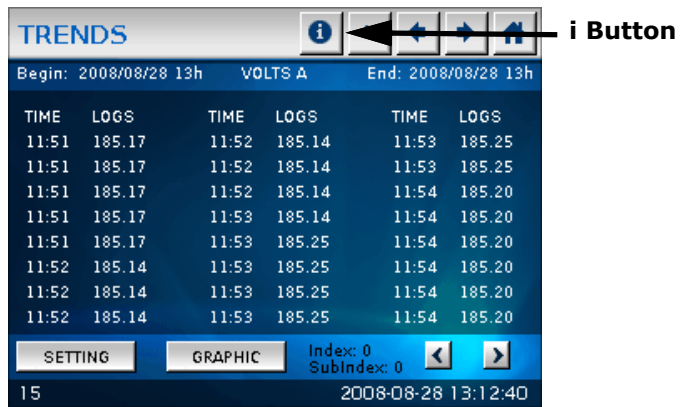

2. The System screen will be displayed, now showing the Test Mode button. Enter Test Mode by pressing the Test Mode button.

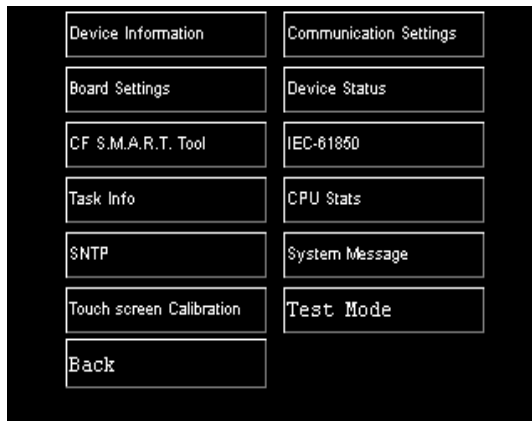

- Select the energy compensation type (it should be the same as the compensation that has been set up for the meter in the device profile).

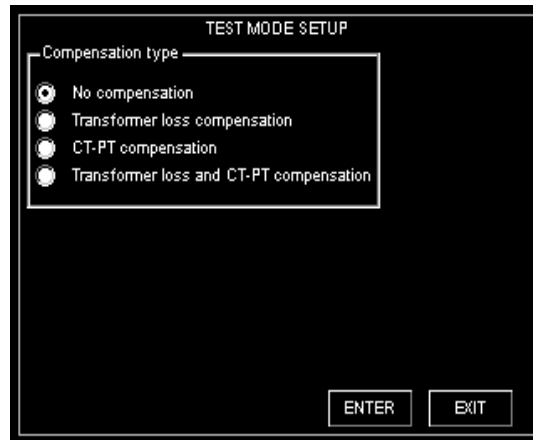

- Press ENTER to start Test Mode. If password protection has been enabled, after you press ENTER you will be prompted to enter the password.
- The display shows a screen with Test Mode data and timestamp, your Mode of Operation selection, Exit and Reset Buttons, and Test Mode status, e.g., Active - no comp(ensation).

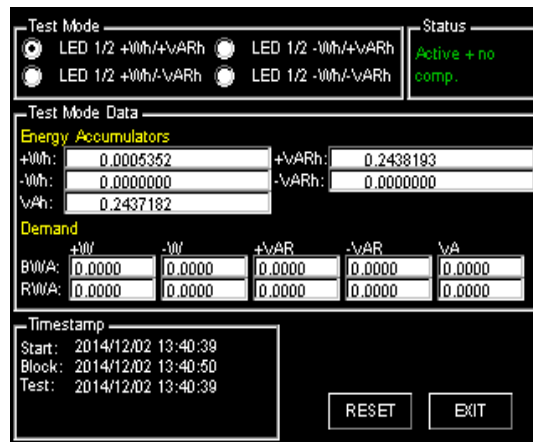

You can:

- Exit Test Mode by pressing EXIT. (Note that the meter will time out of Test Mode after the programmed amount of time - see Section 12.4.)
- Reset Test Mode data by pressing RESET.
- Change the Test Mode's Mode of Operation by pressing one of the radio buttons at the top of the screen.

12.2.3 Entering Test Mode through a Communication Port

To enter Test Mode through a communication port:

- Connect to the meter through Modbus via any of its communication ports.

2. Send a write command to address E031H to enter Test Mode and to select a compensation type. If a password is enabled, the meter will request that you enter the Level 2 password. The meter's display will automatically show the Test Mode screen.
3. While in Test Mode, you can:
 - Send a write command to address E031H to select a specific Test Mode operation
 - Send a read command to address E031H to verify that the meter is in Test Mode
 - Exit Test Mode by sending a write command to address E031H
 - Reset Test Mode data to zero by sending a write command to address E031H



Note that access to Test Mode through a communication port can be password restricted for security (see the *GE Communicator Instruction Manual* for instructions); additionally, access to Test Mode through an Ethernet card can be disabled (see the *GE Communicator Instruction Manual* for instructions).

12.3 Power Loss During Test Mode

In the event of a power outage, Test Mode data is not saved. Upon power up the meter returns to Normal Mode. The Test Mode data is lost, and all registers are restored to their pretest values.

12.4 Test Mode Timeout

Test Mode timeout enables the meter to return from Test Mode to Normal Mode when there is no user interaction with the meter either through the display or through a communication port for a certain period of time, called the Timeout Delay. The Timeout Delay is programmed in the device profile. There are two conditions that activate the Test Mode Timeout Delay:

- Total power is zero: when the meter doesn't recognize a measurable load (total power is equal to zero) and it doesn't observe any user interaction, the meter exits Test Mode automatically after the Timeout Delay.
- Total power is not zero: when the meter does recognize a measurable load (total power is more than zero) but it does not observe any user interaction, the meter exits Test Mode automatically after an extended delay, which consists of the Timeout Delay plus the time it takes to perform either one full block or a sliding window demand average.

12.5 12.5: Test Mode Restrictions

While the meter is in Test Mode it is restricted from resetting the following values:

- Meter energy
- TOU accumulations
- Max/Min values

- Pulse accumulations
- KYZ count
- Cumulative demand
- Logs
- Total Average PF
- Flicker values

In addition, while in Test Mode, the meter will not trigger limits, update Thermal Average values, or perform One Cycle and Tenth Second value updates.

Multilin™ EPM 9900P

Appendix A: Installing the USB Virtual Comm Port

A.1 Introduction

As mentioned in Chapter 5, GE provides a driver (for operating systems earlier than Windows® 7) that allows you to configure the EPM 9900P meter's USB port as a Virtual Serial port. The driver is on the CD that came with your meter. Follow the instructions in this chapter to install the driver and connect to the meter's Virtual port.

A.2 Installing the Virtual Port's Driver

1. Insert the EPM 9900P Meter Series CD into your PC's CD drive.



- Click the **EPM 9900P** button. The following screen opens in your browser.



- Click the **Software** button at the top of the screen and click **USB Driver**.
- The setup program opens a DOS command screen on your PC, as shown below. You will see a message indicating that the driver is being installed.

```
C:\> C:\DOCUME~1\LOCALS~1\Temp\ckz_TJU8\DPInst_Monx86.exe
32-bit OS detected
"C:\DOCUME~1\LOCALS~1\Temp\ckz_TJU8\DPInstx86.exe"
Installing driver.....
```

Once the driver installation is complete, you will see the following message on the DOS command screen.

```
C:\> C:\DOCUME~1\LOCALS~1\Temp\ckz_TJU8\DPInst_Monx86.exe
32-bit OS detected
"C:\DOCUME~1\LOCALS~1\Temp\ckz_TJU8\DPInstx86.exe"
Installing driver.....
FTDI CDM Driver Installation process completed.
Press enter.
```

- Press **Enter**. The DOS screen closes.
- Plug a USB cable into your PC and the EPM 9900P meter's USB port. You will see pop-up message windows telling you that new hardware has been found and that it is installed and ready to use.

A.3 Connecting to the Virtual Port

1. Open GE Communicator.
2. Click the **Connect** icon. You will see the Connect screen shown.

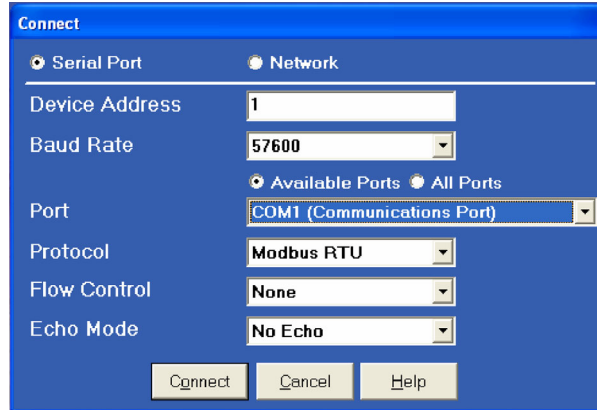

3. Click the **Serial Port** and **Available Ports** radio buttons and select the virtual COM Port. To determine which COM Port is the USB virtual COM port, follow these steps:
 - i On your PC, click **Start>Settings>Control Panel**.
 - ii Double-click on the System folder.

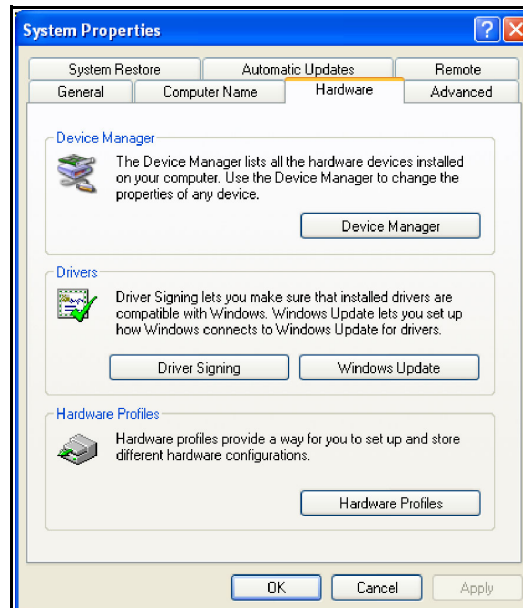

- iii Click the **Hardware** tab. You will see the screen shown on the right.
- iv Click the **Device Manager** button. You will see a list of your computer's hardware devices.

- v Click the plus sign next to Ports (COM & LPT). The COM ports will be displayed. The USB Serial Port is the Virtual port. See the example screen shown.

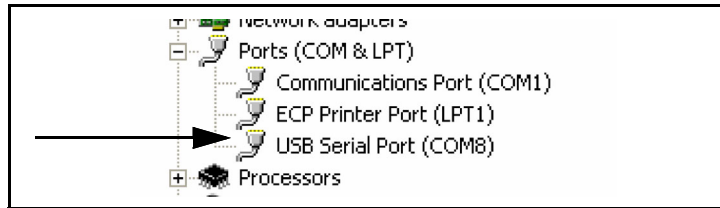

In this example, COM8 is the Virtual port: COM8 is the port you select in the Connect screen.



You can also identify the port configured for the USB by looking at all of the ports in the pull-down list, once you have selected the Available Ports radio button.

Multilin™ EPM 9900P

Appendix B: IEC 61850 Ethernet Network Server

B.1 Overview of IEC 61850

With Software Options B and C, either of the EPM 9900P meter's two Network cards (Main or optional) has the ability to function as an IEC 61850 Protocol Ethernet Network server. (Note that only one of the cards at a time can be enabled as the IEC 61850 Protocol server.) With the IEC 61850 Protocol Ethernet Network server added to the EPM 9900P meter, the unit becomes an advanced intelligent Device that can be networked on a IEC 61850 standard network within an electrical distribution system.

IEC 61850 is a standard for the design of electrical substation automation, including the networking of substation devices. The IEC 61850 standard is part of the International Electrotechnical Commission's (IEC) Technical Committee 57 (TC57). It consists of a suite of protocols (MMS, SMV, etc.) and abstract definitions that provide a standardized method of communication and integration to support intelligent electronic devices from any vendor, networked together to perform protection, monitoring, automation, metering and control in a substation environment. For more information on IEC 61850 go to <http://iec61850.ucaiug.org/>.

IEC 61850 was developed to:

- Specify a design methodology for automation system construction.
- Reduce the effort for users to construct automation systems using devices from multiple vendors.
- Assure interoperability between components within the automation system.
- "Future-proof" the system by providing simple upgrade paths as the underlying technologies change.
- Communicate information rather than data that requires further processing. The functionality of the components is moved away from the clients (requesters) toward the servers (responders).

IEC 61850 differs from previous standards in that:

- The GOOSE communication used by IEC 61850 is a unique and powerful tool that communicates information system-wide. GOOSE sends messages via Ethernet packets to all the devices in the system, in multicast mode, and the appropriate devices respond to those messages.
- It specifies all aspects of the automation system from system specifications, through device specifications, and then through the testing regime.
- The IEC 61850 standard specifies a layered approach to the specification of devices. The layered approach allows “future-proofing” of basic functionality by allowing individual “stack” components to be upgraded as technology progresses.
- The individual objects within devices are addressed through a hierarchy of names rather than numbers.
- Each object has precise, standard terminology across the entire vendor community.
- Devices can provide an online description of their data model.
- A complete (offline) description language defines the way all of the parts of the system are handled, giving a consistent view of all components within the system.

The IEC 61850 standard was developed for electrical substation automation, but has been applied to Distributed Energy resources, distribution line equipment, hydro-electric power plants, and wind power plants.

B.1.1 Relationship of Clients and Servers in IEC 61850

The understanding of the roles of clients and servers and publishers and subscribers is key to the use of IEC 61850 devices.

Client/Server Communication

A client is the requester (sink) of information while the server is the responder (source) of information. Information generally flows on a request-response basis with the client issuing the request and the server issuing the response. However, the concept of servers is extended to provide autonomous transmissions when “interesting” events occur within the server. This information flow is always to the client requesting this “interesting information.” Clients are the devices or services which “talk” to IEC 61850 servers. The function of the client is to configure the server “connection,” set up any dynamic information in the server, enable the reporting mechanisms, and possibly interrogate specific information from the server. Most clients are relatively passive devices which await information from the server but perform little direct ongoing interactions with them except for control operations.

Some clients are used for diagnostic purposes. These devices generally perform ongoing direct interrogation of the servers. A specific example is the “desktop client,” where the engineer remotely diagnoses system problems or retrieves data which is not normally sent from the server (for example, power quality information).

IEC 61850 clients are highly interoperable with IEC 61850 servers. Clients are able to retrieve the server object directory (when needed) and then perform any allowable operation with that server.

Example clients include: Omicron IED scout, SISCO AX-S4 61850, TMW Hammer, KalkiTech gateway, Siemens DIGSI.

An example of the object model display on a diagnostic client is shown in Figure B-1: Object Model Display Example.

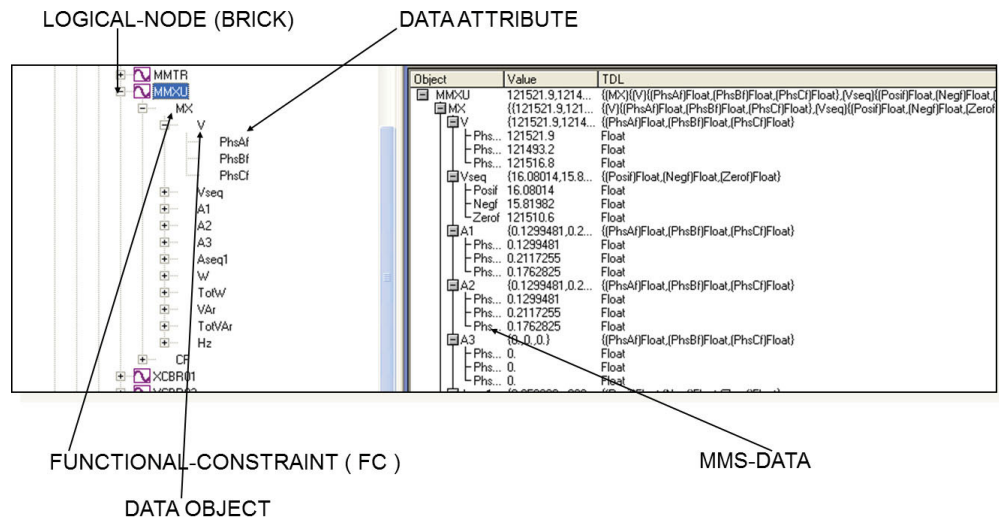

Figure B-1: Object Model Display Example

Publisher/Subscriber Communication (GOOSE)

There is an additional, essential relationship in IEC 61850, known as publisher and subscriber, which is the method used in GOOSE messaging. The publisher/subscriber relationship differs from the client/server in that there is no explicit one-to-one relationship between the information producer and consumer. Publishers issue data without knowledge of which devices will consume the data, and whether the data has been received. Subscribers use internal means to access the published data. From the viewpoint of IEC 61850, the publisher/subscriber mechanism uses the Ethernet multicast mechanism (i.e., multicast MAC addresses at layer 2). The communication layer of the system is responsible for transmitting this information to all interested subscribers and the subscribers are responsible for accepting these multicast packets from the Ethernet layer.

The publish/subscribe mechanism is used both for GOOSE and Sampled Value services. GOOSE is fully supported by the EPM 9900P meter's IEC 61850 Protocol Ethernet Network server. In addition, the EPM 9900P meter adds a unique, powerful implementation to GOOSE, by using it to send alarm/limit messages that trigger waveforms whenever there is a power quality event. In this way, if there is a power anomaly, there will be multiple captures of the event so that a detailed analysis can be performed. See Section C.1.4.2: GOOSE on page C-13, for information on the EPM 9900P meter's GOOSE implementation.

B.1.2 Structure of IEC 61850 Network

As mentioned before, IEC 61850 lets you set up an automated communication structure for devices from any vendor. In order to set up this network, IEC 61850 renames devices (e.g., meters), measured parameters (e.g., Phase to Phase

Voltage), and functions (e.g., reporting) into a specific language and file structure. This way all of the elements of the network can function together quickly and effectively. The language that the IEC 61850 network uses is structured, that is it is very specific in how the system information is entered, and hierarchical, which means that it has different levels for specific information; for example, meter information is entered on one level, and the information about the actual physical connection between meters and other hardware is entered on another level.

The structure of the IEC 61850 network is composed of different kinds of files, each containing information that the system needs in order to function. IEC 61850 configuration uses text-based (XML) files known as the System Configuration Language (SCL). SCL files use the concept of an XML schema, which defines the structure and content of an XML file. The schema used by SCL files describes most (though not all) of the restrictions required to ensure a consistent description file. An SCL file superficially looks like an HTML file. It consists of 6 parts:

- Prologue: XML declaration, (XML) namespace declarations, etc.
- Header element: Names the system and contains the file version history
- Substation element: defines the physical structure of the system
- Communication element: defines all device-to-device communication aspects
- IED element: defines the data model presented by each communicating device
- DataTypeTemplates element: contains the detailed definition of data models.

After it is written, the XML file can be checked by "validators" against the schema using freely available tools.

The IEC 61850 network uses four types of SCL files, each with identical structure:

- SSD - System Specification Description: used during the specification stage of a system to define physical equipment, connections between physical equipment, and Logical Nodes which will be used by each piece of equipment.
- ICD - IED Capability Description: this is provided by the communication equipment vendor to specify the features of the equipment and the data model published by the equipment. Each of the devices in the network has an ICD file which describes all of the information about the device, for example, IP address on the network and Com ports. The (vendor supplied) ICD variation of the SCL file contains a Communication section specifying the lower-layer selectors and default addressing and also an IED section containing the data model of the device. See the *Configuring the Meter on the IEC 61850 Network* section for information on the EPM 9900P meter's .icd file.
- SCD - System Configuration Description: a complete description of the configured automation system including all devices (for example, meters, breakers, and relays) and all needed inter-device communications (for example, the measured parameters and the actions to be performed, such as turning on a relay when a certain reading is obtained). It can also include elements of the SSD file. The SCD file is created by a System Configurator, which is a software application that takes the information from the various devices along with other configuration parameters and generates the SCD file.
- CID - Configured IED Description: the file used to configure an individual device. It is a pure subset of the SCD file. The device may also have a CID file, which is a smaller subset of the device's ICD file. The CID file describes the exact settings

for the device in this particular IEC 61850 network. The EPM 9900P meter's IEC 61850 Protocol Ethernet Network card uses a CID file. See the *Configuring the Meter on the IEC 61850 Network* section for instructions for uploading the EPM 9900P meter's .cid file.

Each type of SCL file has different required elements with only the prologue and Header element required in every file type.

Elements of an IEC 61850 Network

- A physical device has a name (IEDname) and consists of one or more AccessPoints.
- An AccessPoint has an IP address and consists of one or more Logical Devices
- A Logical Device contains LLN0 and LPHD1 and optional other Logical Nodes.
- LLN0 (Logical Node Zero) is a special object which "controls" the Logical Device. It contains all of the datasets used for unsolicited transmission from the device. It also contains the report, SV, and GOOSE control blocks (which reference the datasets).
- LPHD1 (Physical Device) represents the hardware "box" and contains nameplate information.
- Logical Nodes (LNs) are standardized groups of "Data Objects" (DOs). The grouping is used to assemble complex functions from small groups of objects (think of them as building blocks). The standard defines specific mandatory and optional DOs for each LN. The device may instantiate multiple LNs of the same type differentiated by either a (named) prefix or (numerical) suffix.
- Data Objects represent "real-world" information, possibly grouped by electrical object. The IEC 61850 standard has specific semantics for each of the DOs. For example, the DO named "PhV" represents the voltage of a point on a three-phase power system. The DOs are composed of standardized Common Data Classes (CDCs) which are groups of low-level attributes of the objects. For example, the DO named "Hz" represents system frequency and is of CDC named "MV" (Measurement Value).
- Common Data Classes (CDCs) consists of standardized groups of "attributes" (simple data types). For example, the attribute "instMag" represents the instantaneous magnitude of the underlying quantity. The standard specifies mandatory and optional attributes for each CDC. For example, the DO named "Hz" in Logical Node class MMXU contains a mandatory attribute named "mag" which represents the deadbanded value of the frequency. The physical device contains a database of data values which map to the various structures described above. The database values are manipulated by the device to perform actions such as deadbanding (holding a constant value until the underlying value changes by more than a specified amount) or triggering of reports.
- As explained earlier, GOOSE messaging is essential to an IEC 61850 Network. That is because GOOSE messaging allows very rapid communication to all devices in the system, allowing the appropriate devices to respond to the messages. For example, in the EPM 9900P IEC 61850 implementation, GOOSE is used to transmit alarm/limit information when a programmed limit is exceeded, so that all enabled EPM 9900P meters can capture a waveform at the time of the alarm. See Section C.1.4.2: GOOSE, for detailed information.

B.1.3 Steps to Configuring an IEC 61850 Network

1. The first thing needed is the SSD for physical connections, then the vendor-provided ICD files which are combined into a SCD file by a vendor-independent System Configurator. The System Configurator assigns addresses to the equipment and sets up datasets, reports, etc. for inter-device communication. The system configurator will create an "instance" of the configured device by applying the following information:
 - The name of the device
 - The IP address, subnet mask, and IP gateway of the device
 - Datasets: the user must decide which information within the IED will be included in reports, etc. and place this information into datasets. The System Configurator should allow the selection of information using a "pick list" from information within the ICD file.
2. The resulting SCD file is then imported by vendor-specific tools into the various devices. Some vendors add the additional step of filtering the SCD file into a smaller file containing only information needed by the specific device, resulting in a CID file which is used to configure the device. The actual configuration of the device is left unspecified by IEC 61850 except to require that the SCD file remains the source of the configuration information. In this way, consistency of the information across the whole system is maintained.

See Figure B-2 for a graphical illustration of the process.

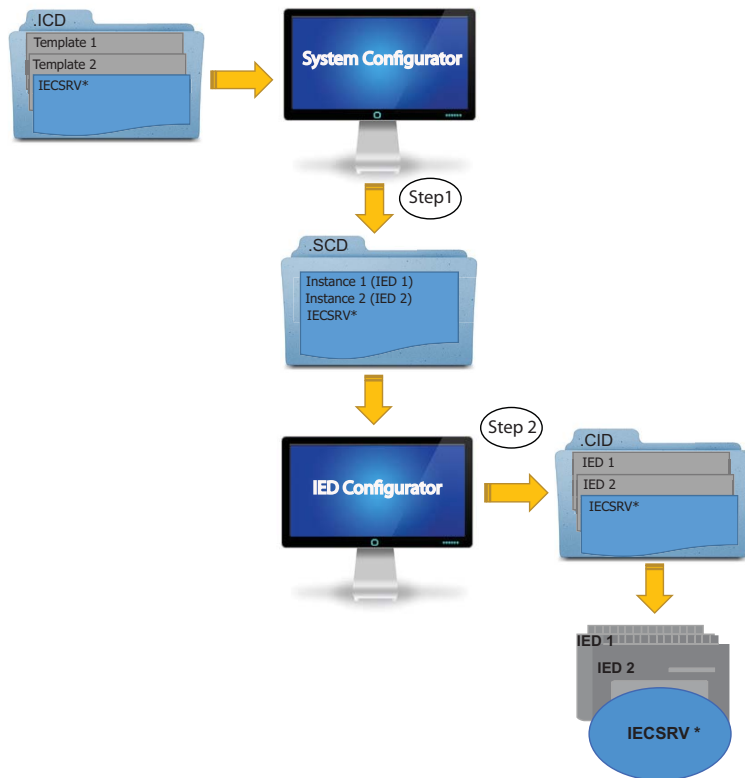

*IECSRV is the name of the meter in the IEC 61850 System

Figure B-2: IEC Network Configuration Process Example

Referring to Figure B-2:

In step 1, the IED template is provided by the vendor (or sometimes created by a vendor tool). This file is imported into the vendor-independent tool, the System Configurator, along with other device templates. The System Configurator uses these templates to set up the correct number of IEDs in the system and then provides configuration information. The configuration information consists of providing addresses for all IEDs in the system, creation of datasets, configuring control blocks, and setting individual device parameters such as analog deadbands. The System Configurator then creates a SCD file with a consistent view of the entire system.

In step 2, the SCD file is used to configure each device using vendor-supplied tools. Vendors are free to choose the configuration mechanism, but the configuration information MUST be derived from the SCD file.



In the EPM 9900P meter's IEC 61850 Protocol Ethernet Network server implementation, every service and object within the server is defined in the standard (there is nothing non-standard in the device).

Also in step 2, the user sets up report control blocks, buffered and unbuffered, for each of the clients. Setup information includes the dataset name, a report identifier, the optional fields to be used in the report, the trigger options, buffer time (delay from first event to report issuance), and integrity time (server periodic reports of all data in dataset). The decision whether to use buffered or unbuffered must be decided by the user.

Finally, in step 2 the System Configurator performs a consistency check and then outputs the SCD file. The SCD file is imported by the "ScdToCid" tool where the user specifies the device name.

The resulting CID file is then imported into the target device.

B.1.4 GE VERNOVA's IEC 61850 Implementation

There are two overall parts to GE VERNOVA's IEC 61850 implementation- the IEC 61850 Protocol Server and GOOSE.

IEC 61850 Protocol Server

Following are features of GE VERNOVA's implementation of the IEC 61850 Protocol Server:

- The lower-level addressing uses PSEL=00000001, SSEL=0001, and TSEL=0001.
- At the server level, each implements a single Logical Device name formed by concatenating the IED name (chosen by the System Configurator) and "Meas" (e.g., "MyDeviceMeas").
- The Logical Nodes implemented within the Logical Device include the standard LLN0 and LPHD1 with optional standard logical nodes in the "M" class (e.g., "MMXU") and "T" class (e.g., "TVTR"). Each Logical Node contains only standardized objects of standardized types (Common Data Class, CDC). The device is based upon the first edition of the IEC 61850 standards.
Examples of Logical Nodes within the EPM 9900P family include eneMMTR1 (energy metering) and nsMMXU1 (normal speed Measurement Unit).
- The EPM 9900P device will get its IED name from the first <IED> section in the configuration file (.cid). This name will be used for accessing its access point (IP

address) and its single Logical Device named "Meas". The IED name can be composed of any string of up to 32 (alphanumeric only) characters.

- The logical nodes implemented in the EPM 9900P meter are listed below:
 - The node LLN0 keeps common information for the entire logical device. In this node Datasets and Reports can be defined, based on the limitations provided in the ICD file: the EPM 9900P meter supports up to 32 datasets with up to 256 attributes each, and up to 16 report control blocks. The report control blocks and datasets must be configured in the CID file, although the options, triggers and integrity period can be dynamically configured by the IEC client.
 - The node LPHD1 defines physical parameters such as vendor, serial number, device name plate and the software revision number.
 - The node nsMMXU1 contains the "normal-speed" basic electrical measurements such as Volts / Amps / Watts / VARs / Frequency / Power Factor / etc. The electrical measurements are data objects in hierarchical structure as per the IEC 61850 specifications.

For example, Phase A voltage:

- which is in the object "PhV"
- which is of type "WYE_ABC_mag_noDC"
- which in turn has the object "phsA"
- which again has an attribute named "instVal" to represent instantaneous values, and also the "mag" attribute, which represents the magnitude as an analog magnitude, with the attribute "f" to get the value in 32-bit floating point.

Thus the voltage of phase A, would be referred in this nested structure as "Meas/nsMMXU1.PhV.phsA.instVal.mag.f".

- The node hsMFLK1 is used for short term flicker (per phase) and long term flicker (per phase); hs stands for "high speed" (200msec).
- The node nsMHAI1 groups together the THD per phase measurements taken at normal speed.

Following the previous example, the THD for phase A would be referred as "Meas/nsMHAI1.ThdPhV.phsA.instCVal.mag.f".
- The node 1sMSQ11 is used for voltage/current symmetrical components perphase (zero, positive and negative); 1s stands for "low speed" (3 seconds).
- The node eneMMTR1 groups together all measurements related to energy counters, like +/- Watt;hours, +/- VAR-hours and Total VA-hours.
- The node intGGIO1 is used for the built-in high-speed digital inputs; the node extGGIO1 is used for the slot 3 option board's digital inputs; the node extGGIO2 is used for the slot 4 option board's digital inputs.
- The nodes setTCTR1, setTCTR2, setTCTR3 and setTCTR4 contain the ratio of the current used by the measuring device, for phases A,B,C and Neutral, respectively. In this way, the user can take the IEC measurements (primary) and convert them to Secondary using the ratios contained in these nodes.
- The nodes setTVTR1, setTVTR2 and setTVTR3 contain the ratio of the voltage used by the measuring device.
- Any of the defined objects/ attributes can be placed within a dataset.

- The normal-speed in the EPM 9900P meter is measurements taken every second. The energy counters are also updated every second.
- The configuration of the devices takes place by converting the SCD file exported by the System Configuration tool into a CID file. This CID file contains all of the information from the SCD file which is needed for configuration by the GE device. The tool is named "SCDtoCIDConverter" and is a simple, publicly available program. The resulting CID file is then sent to the GE device using HTTP file transfer.

GOOSE

The GOOSE implementation enables the EPM 9900P meter with the IEC 61850 server to:

- Send and receive (publish/subscribe) messages
- Send messages when programmed limits have been exceeded
- Receive messages of exceeded limits and trigger waveforms in response to them
- Enabling GOOSE, configuring limits, and selecting the limits that will trigger waveform capture is done in the Device Profile. See *IEC 61850 Protocol Server* on page B–7, for instructions.
- The programming of the GOOSE send and receive of messages is done in the CID file.

Refer to the figure below for an illustration of GOOSE functionality.

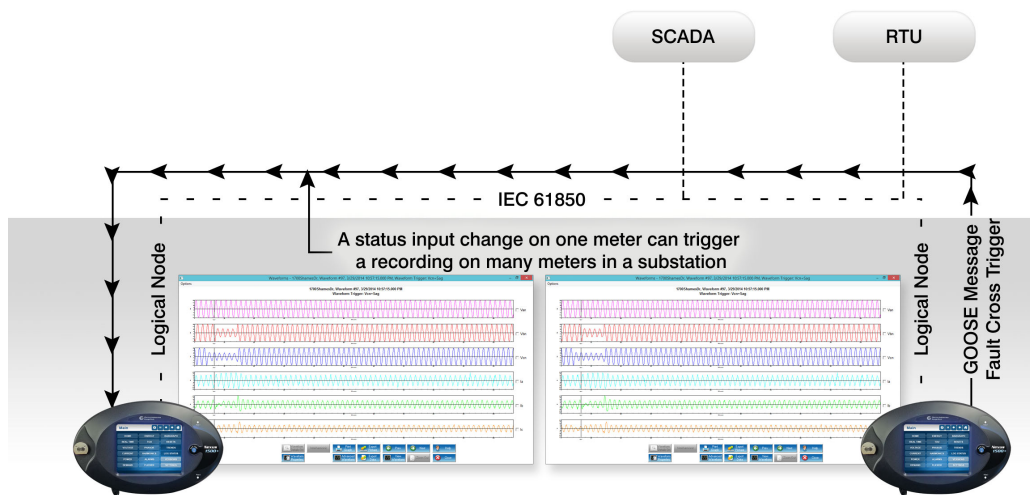

Figure B-3: GOOSE Cross-triggering of Waveforms

EPM 9900P IEC 61850 Server Configuration

The configuration file (CID) should be stored in the EPM 9900P meter in order to configure the server. At power up the server reads the file, parses it and configures all the internal settings for proper functionality.

Storing the CID file in the EPM 9900P meter is accomplished through its webpage. The webpage allows the user to locate the CID file, and submit it to the EPM 9900P meter for storage.

After storing the CID file, access the EPM 9900P meter's webpage again, to make sure that the file has been stored, and to see if there is any problem with it, by checking its status. The CID file will be successfully updated if the IP address inside the .cid file matches with the one programmed into the device profile.

- A common problem is IP mismatch (the IP address in the CID file does not match the IP configured in the EPM 9900P meter's device profile). In this case the

EPM 9900P meter will use the IP address from its device profile, and the IEC Server will work only with that address.

- If there is a critical error in the stored CID file, which prevents the IEC Server from running, the CID file will not be used, and instead the Default CID file (embedded in the server) will be used. The webpage will alert you to this situation.
- If further details are needed, for example, information on the reason the CID storage failed, the web server provides a link to the system log. In the system logscreen you can view messages from the IEC 61850 parser, and you can take actions to correct the error.

See *B.2 Using the IEC 61850 Ethernet Network Server* for instructions on configuring the EPM 9900P meter's IEC 61850 Protocol Ethernet Network server.

B.1.5 Reference Materials

More information is available in the *EPM 9900P IEC 61850 Guide*.

Following is a list of background information on IEC 61850 that is available on the Internet:

- http://www.sisconet.com/downloads/IEC61850_Overview_and_Benefits_Paper_General.pdf
- <http://www.sisconet.com/downloads/CIGRE%202004%20Presentations.zip> (IEC618650 Presentation IEC 61850 û Data Model and Services.pdf)
- http://www.ucaiug.org/Meetings/Austin2011/Shared%20Documents/IEC_61850-Tutorial.pdf (pages 24-32 and 40-161)
- <http://brodersensystems.com/wordpress/wp-content/uploads/DTU-Master-Thesis-RTU32.pdf> (pages 9-36)

Additionally, there is a good article on the predecessor to IEC 61850 (UCA 2.0) at <http://www.elp.com/index/display/article-display/66170/articles/utility-automationengineering-td/volume-5/issue-2/features/uca-20-for-dummies.html>.

Another article on multi-vendor IED integration can be found at <http://www.gegridsolutions.com/smartgrid/Aug07/EIC61850.pdf>.

B.1.6 Free Tools for IEC 61850 Start-up

The Internet also provides some free IEC 61850 configuration tools:

- Schema validation tools: <http://notepad-plus-plus.org/go> to plug-in manager and install XML tools (however, there is no (legal) public copies of the schema available). However, a web search file the filenameSCL_Basetypes.xsd turns up many copies and the entire set of XSD file is often nearby.
- <http://opensclconfig.git.sourceforge.net/> Apparent open-source project, not tested
- <http://www.sisconet.com/downloads/SCDtoCIDConverter0-9.exe> filters SCD file to a CID file
- <http://www.sisconet.com/downloads/skunkworks2-8.exe> Ethernet analyzer

B.1.7 Commercial Tools for IEC 61850 Implementation

Following is a list of tools for IEC 61850 configuration which you can purchase:

- http://www.sisconet.com/ax-s4_61850.htm Client for IEC 61850
- [http://products.trianglemicroworks.com/documents TMW%2061850%20Test%20Suite%20Combined.pdf](http://products.trianglemicroworks.com/documents/TMW%2061850%20Test%20Suite%20Combined.pdf)
Clients and servers for IEC 61850
- [http://www.omicron.at/en/products/pro/communication-protocols/iedscout/test client](http://www.omicron.at/en/products/pro/communication-protocols/iedscout/test-client)
- <http://kalkitech.com/products/sync-6000-series-scl-manager--iec61850-substation-design-tool> SCL editing tool

B.2 Using the IEC 61850 Ethernet Network Server

This section contains instructions for understanding and configuring the EPM 9900P meter's IEC 61850 Protocol Ethernet Network server.

B.2.1 Overview

The IEC 61850 Protocol Ethernet Network card is a EPM 9900P standard I/O board. It is available via Ethernet port 1 with Software Options B and C. The IEC 61850 Protocol Ethernet Network server has the following features:

- Standard Ethernet 10/100 Mbps connector is used to link the unit into an Ethernet network.
- Standard operation port 102, which can be reconfigured to any valid TCP/IP port.
- Up to 6 simultaneous connections can be established with the unit.
- Configurable via the .CID file (XML formatted)
- Embedded Capabilities File (.ICD downloadable from the unit)
- Supports MMS protocol.
- Supports the following Logical Nodes:
 - LLN0 (with predefined Sets and Reports)
 - LPHD (Identifiers)
 - MMXU with
 - Phase-to-N Voltages
 - Phase-to-Phase Voltages
 - Phase Currents
 - Per Phase VA
 - Total VA
 - Per Phase Var
 - Total Var
 - Per Phase W
 - Total W
 - Per Phase PF
 - Total PF

- Frequency
- MHA1 with Per Phase THD for voltage and current
- MSQ1 with
 - Voltage symmetrical components per phase (zero, positive and negative)
 - Current symmetrical components per phase (zero, positive and negative)
- MMTR with
 - Demand Wh
 - Supplied Wh
 - Demand Varh
 - SuppliedVARh
 - Total VAh
- GGIO with built-in and option board digital inputs and virtual inputs
- Supports polled (Queried Requests) operation mode.
- Supports Buffered Reports
- Supports Unbuffered Reports

B.2.2 Configuring the IEC 61850 Protocol Ethernet Network Server

You need to configure the IEC 61850 Protocol Ethernet Network server for communication, both from the standpoint of the device (the Device Profile) and of the network (the SCL configuration file, which is a .cid file uploaded to the meter).

Configuring the Device Profile IEC 61850 Protocol Ethernet Network Server Settings

You use the GE Communicator application to set the card's network parameters. Basic instructions are given here, but you can refer to the *GE Communicator Instruction Manual* for additional information. You can view the manual online by clicking Help>Contents from the GE Communicator software main screen.

1. Using GE Communicator software, connect to the meter through its USB port, RS485 serial port, or Ethernet 2 port (see Chapter 5 for instructions on connecting to your meter with GE Communicator software).

2. Click the Profile icon to open the meter's Device Profile screen. The profile is retrieved from the EPM 9900P meter. Double-click General Settings, Communications, and then one of the lines under Communications, to display the screen shown below.

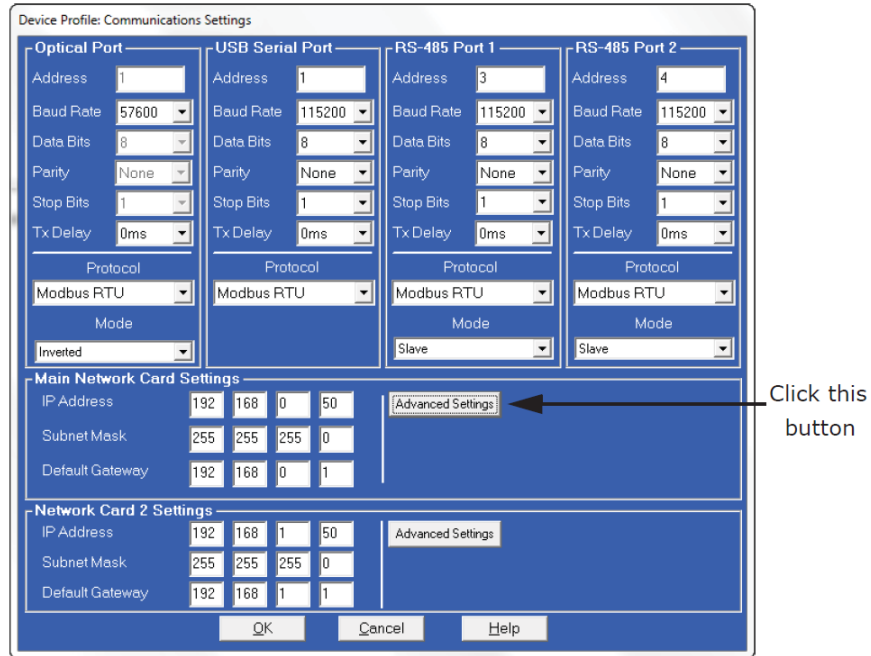

3. Click the **Advanced Settings** button next to the Main Network Card. You will see the next screen shown. Use this screen to enable both IEC 61850 and GOOSE.

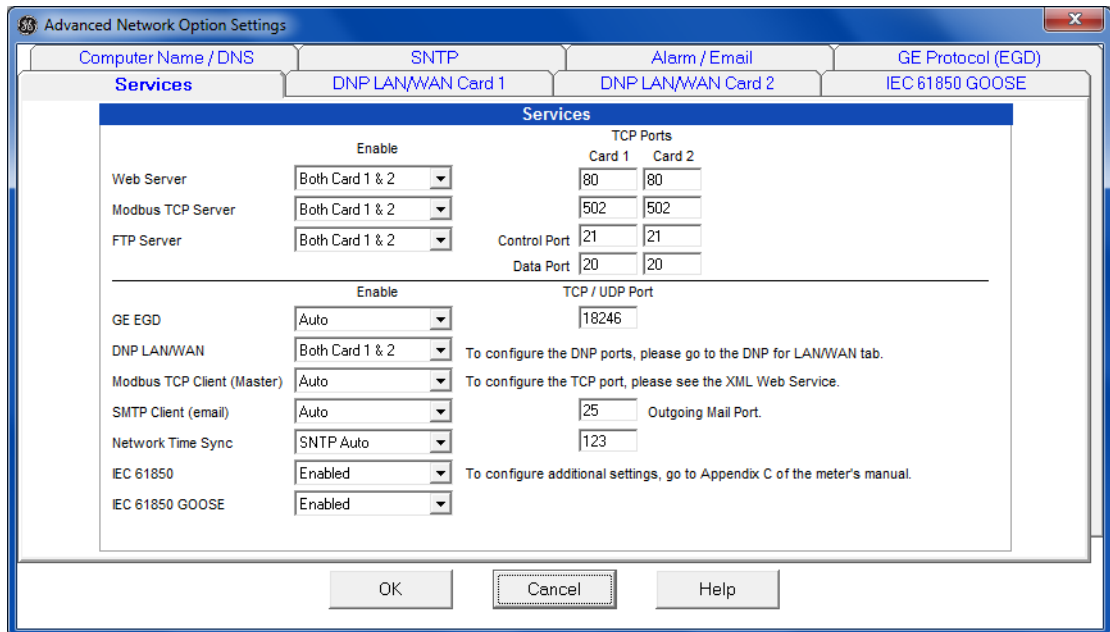

- a. You need to enable the Web Server, Modbus TCP Server, and FTP Server for whichever card you will be using for IEC 61850. Select the card by clicking in the pull-down menu next to these settings.
- b. Enable IEC 61850 and IEC 61850 GOOSE by selecting Enabled from the pulldown menu next to these settings.

- Click the **IEC 61850 GOOSE** tab to set up waveform capture based on limits. You will see the screen shown below.

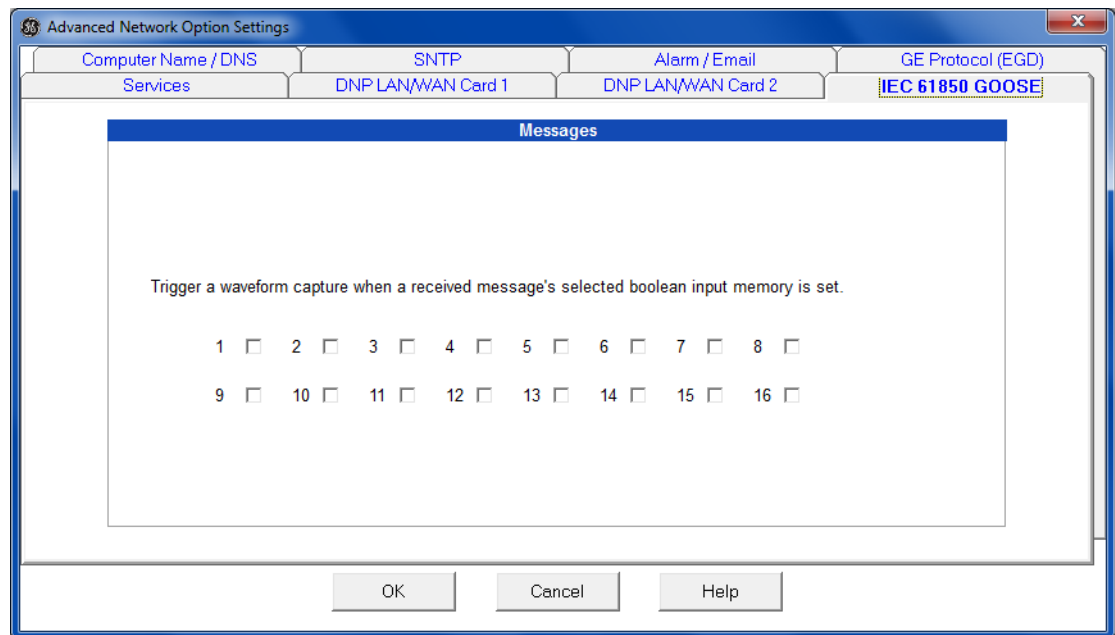

- The numbers 1-16 refer to limits. You configure the limits in the meter's Device Profile. See the *GE Communicator Instruction Manual* for instructions on setting up limits.
- Select the limit(s) you want to use to trigger a waveform capture through GOOSE. When the selected limit is exceeded, the meter's GOOSE will send out the message that will cause all GOOSE-enabled EPM 9900P meters in the IEC 61850 Network to record a waveform.
- Click **OK** and then click **Update Device** to send the settings to the EPM 9900P meter. The meter will reboot. The IEC 61850 Protocol Network server is now configured properly to work on an IEC 61850 network.

Configuring the Meter on the IEC 61850 Network

The System Integrator must configure the EPM 9900P meter within the substation IEC 61850 network. To do this, the System Integrator needs the EPM 9900P capabilities file (.icd) (as well as information about the rest of the devices on the network).

This .icd file, as mentioned earlier, is the SCL file that contains the IEC 61850 nodes, objects, and parameters implemented in the EPM 9900P meter, including the Network IP address.

The IP address for the EPM 9900P meter is contained in the Communication section of this .icd file. See the example Communication section, below.

<Communication>

<SubNetwork name="Subnet_MMS" type="8-MMS">

<BitRate unit="b/s" multiplier="M">10</BitRate>

<ConnectedAP iedName="EPM9900IECSRV" apName="S1">

<Address>

```

<P type="OSI-PSEL" xsi:type="tP_OSI-PSEL">00000001</P>
<P type="OSI-SSEL" xsi:type="tP_OSI-SSEL">0001</P>
<P type="OSI-TSEL" xsi:type="tP_OSI-TSEL">0001</P>
<P type="IP" xsi:type="tP_IP">172.20.167.199</P>
</Address>
</ConnectedAP>
</SubNetwork>
</Communication>
    
```

The node <P type="IP" xsi:type="tP_IP"> (bolded in the example above) defines the meter’s IP address. This IP address must be the same as the IP address configured in the meter’s Device Profile.

The EPM 9900P meter’s .icd file (EPM9900.icd) can be downloaded directly from the meter. To download the file, use FTP to access the file: the file is located in the meter’s compact flash under C:\IEC61850\SCL folder. This folder contains both the meters .icd file and its default .cid file. See the instructions that follow.

1. NOTE:Open the FTP application and select the Connect option. See the example screen below.

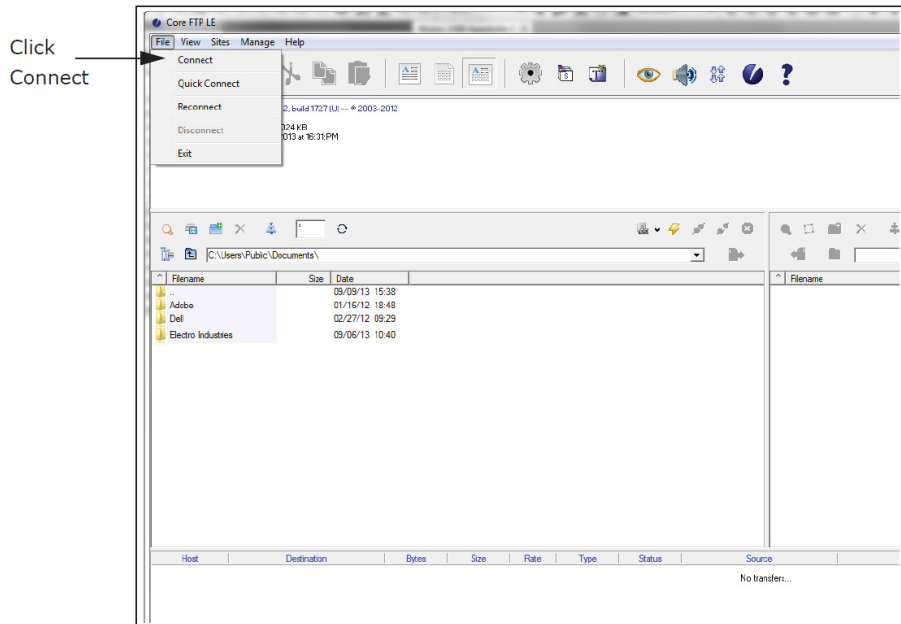

- You will be prompted for the connection information - meter's Main Ethernet card's IP address, username and password (the default value is anonymous/anonymous), etc. See the example screen on the next page.

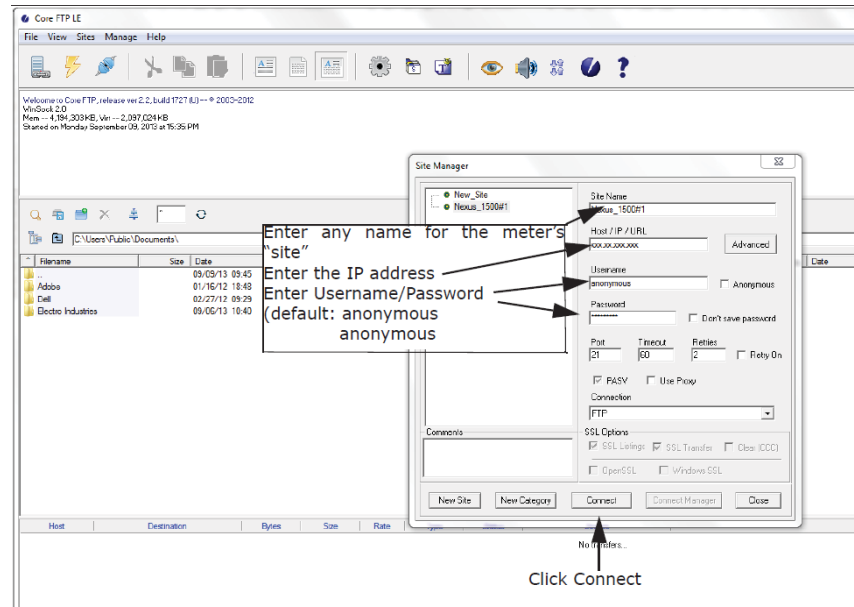

- The FTP application will connect to the meter and you will folders contained in the Ethernet card. Double-click the C folder.

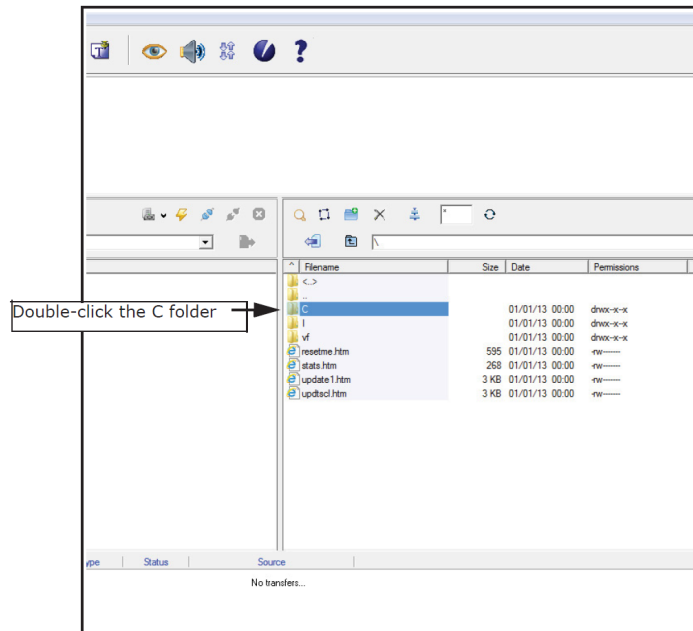

- The screen will now show the folders contained in the C folder. Double-click the IEC61850 folder.

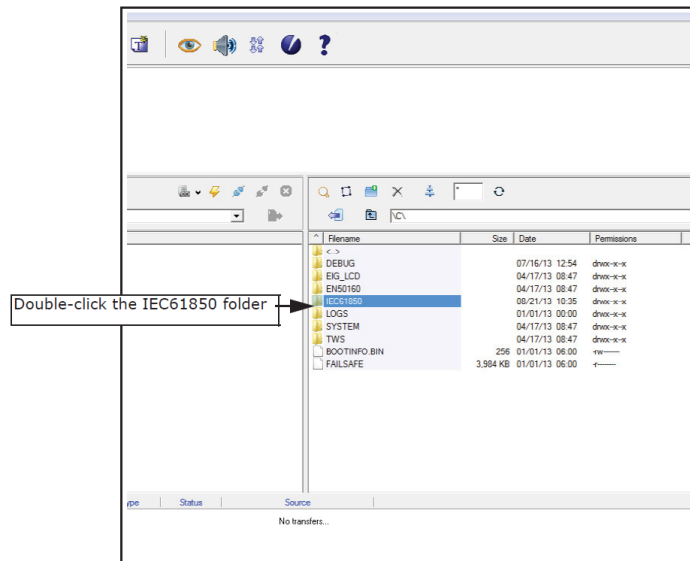

- The screen will show the contents of the IEC61850 folder. Double-click the SCL folder.

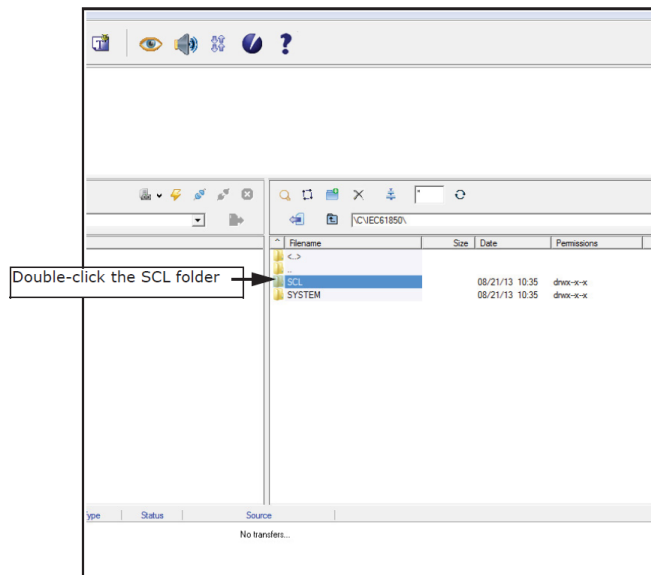

6. The screen will show two files - EPM9900.CID which is the default CID file, and EPM9900.ICD which is the file you want to download and edit.

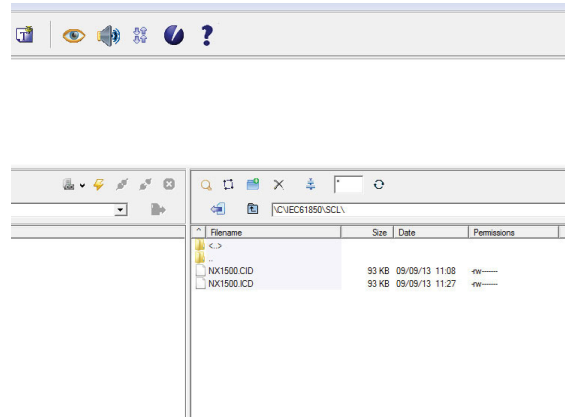

7. Make sure the left side of the screen has the location on your PC that you want to copy the .icd file. Then right-click on EPM9900.ICD and select Download.

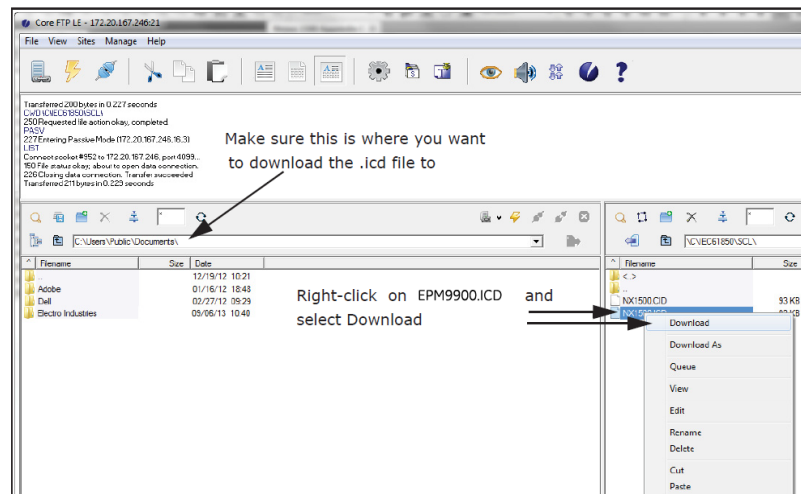

8. The file will be downloaded to your PC, in the location specified. To edit the .cid file, open it in Notepad or any text editor. See the example below.

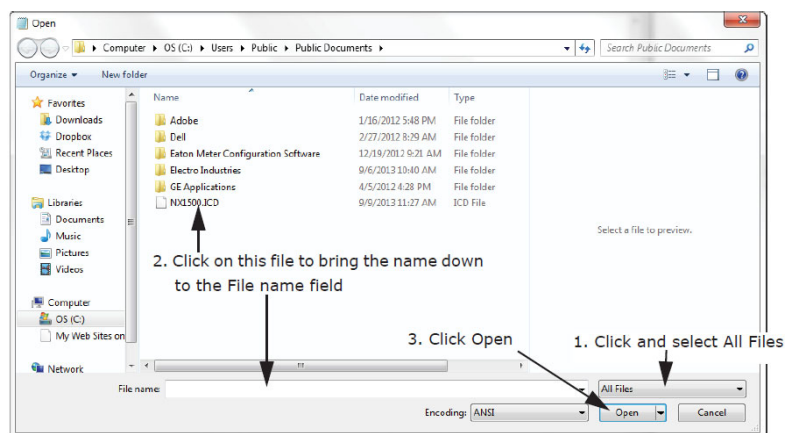

9. The .cid file will open in Notepad.

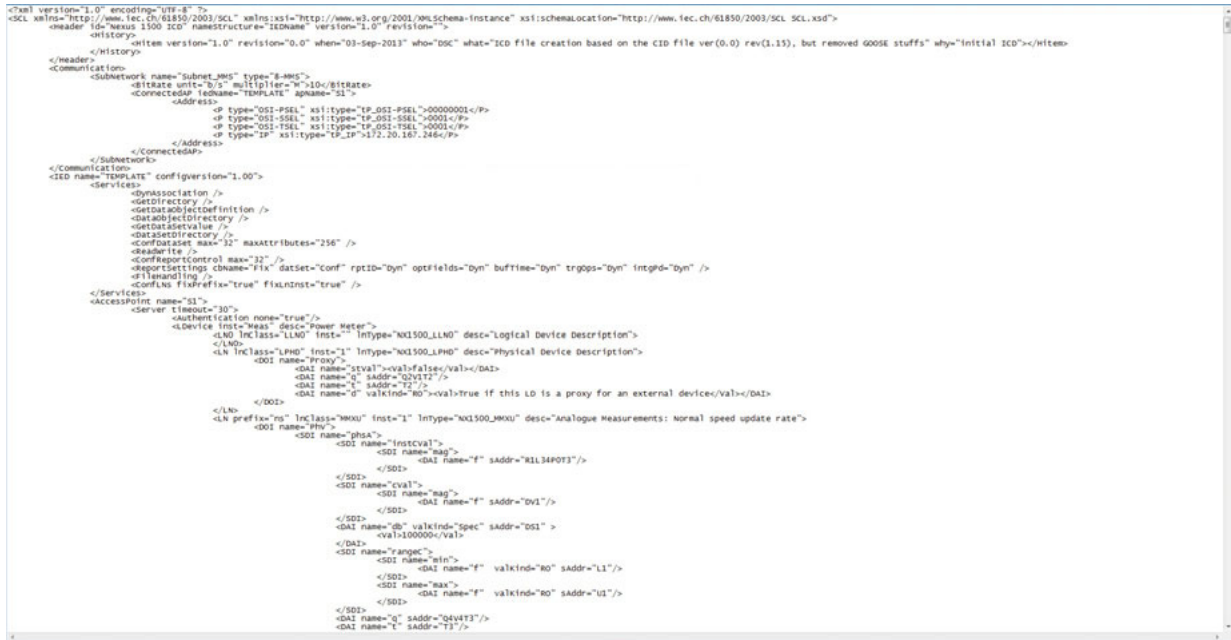

An example of a downloaded .cid file is shown below.

```
<?xml version="1.0" encoding="UTF-8"?>
<SCL xmlns="http://www.iec.ch/61850/2003/SCL" xmlns:xsi="http://www.w3.org/2001/XMLSchema-instance" xsi:schemaLocation="http://www.iec.ch/61850/2003/SCL.xsd"
id="EPM 9900P ICD" nameStructure="IEDName" version="1.0" revision="">
<History>
<Hitem version="0.1" revision="13" when="26-May-2014" who="BAM" what="initial draft" why="initial ICD">
</Hitem>
</History>
</Header>
<Communication>
<SubNetwork name="Subnet_MMS" type="8-MMS">
<BitRate unit="b/s" multiplier="M">10</BitRate>
iedName="EPM 9900PIECSRV" apName="S1">
<Address>
<P type="OSI-PSEL" xsi:type="tP_OSI-PSEL">00000001</P>
<P type="OSI-SSEL" xsi:type="tP_OSI-SSEL">0001</P>
<P type="OSI-TSEL" xsi:type="tP_OSI-TSEL">0001</P>
<P type="IP" xsi:type="tP_IP">10.0.0.24</P>
```

```

</Address>
</ConnectedAP>
</SubNetwork>
</Communication>
<IED name="EPM 9900IECSR" desc="GE Grid Solutions EPM 9900P"
type="E9900P" manufacturer="GE GRID SOLUTIONS" configVersion="1.00">
<Services>
  <DynAssociation/>

```

10. You need to make the following changes to the .cid file:

- Change "TEMPLATE" to the iedName alphanumeric string in 2 places:
 - In <Communication>

```

<SubNetwork name="Subnet_MMS" type="8-MMS">
<BitRate unit="b/s" multiplier="M">10</BitRate>
<ConnectedAP iedName="alphanumeric string" apName="S1">

```
 - <IED name="alphanumeric strin" desc="GE Grid Solutions EP9900"
 type="EPM 9900P" manufacture="GE Grid Solutions" configVersion="1.00"
- Change the IP address to the IP address of the meter's Main Ethernet card:

```

<Communication>
<SubNetwork name="Subnet_MMS" type="8-MMS">
<BitRate unit="b/s" multiplier="M">10</BitRate>
<ConnectedAP iedName="EP9900PIECSR" apName="S1">
<Address>
<P type="OSI-PSEL" xsi:type="tP_OSI-PSEL">00000001</P>
<P type="OSI-SSEL" xsi:type="tP_OSI-SSEL">0001</P>
<P type="OSI-TSEL" xsi:type="tP_OSI-TSEL">0001</P>
<P type="IP" xsi:type="tP_IP">192.168.0.50</P>

```
- Any modifications needed for your specific configuration: creating datasets, reports, etc.

- When you have made your changes to the file, save it as a txt file but with the extension .ICD, as shown below.

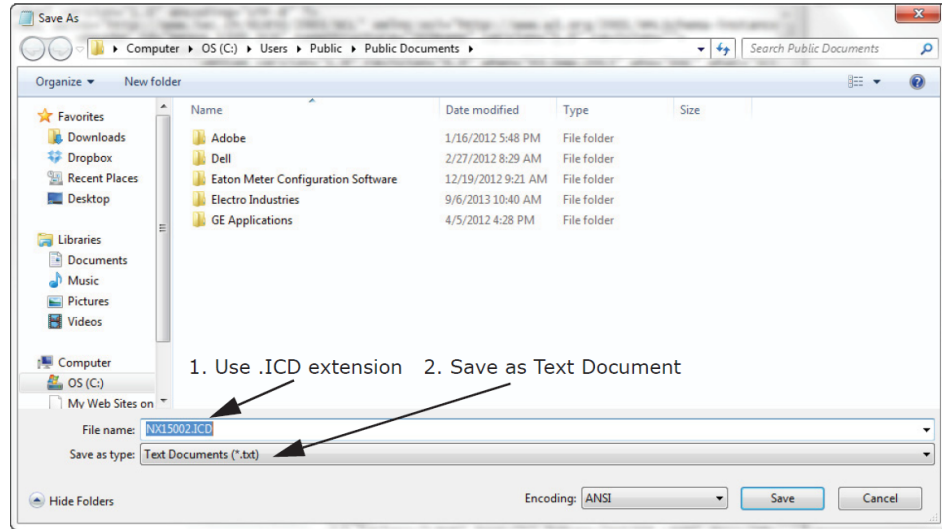

- Once the System Integrator has processed the EPM 9900P meter's .icd file and the information of the other devices on the network (using either automated tools or manually), the final result is a configuration file with the extension ".cid". This file must now be uploaded to the EPM 9900P meter's IEC 61850 Protocol Ethernet network card.
- You upload the .cid file to the meter via its webpage. To do this, use a web browser and key: <http://aa.bb.cc.dd/>
 - where aa.bb.cc.dd is the IP address assigned to the main Network card, which is acting as the IEC 61850 Protocol Ethernet Network server.
 Section 9.4.1 details the meter's webpages.



14. From the top of the screen, click **Tools** to display the webpage shown below.

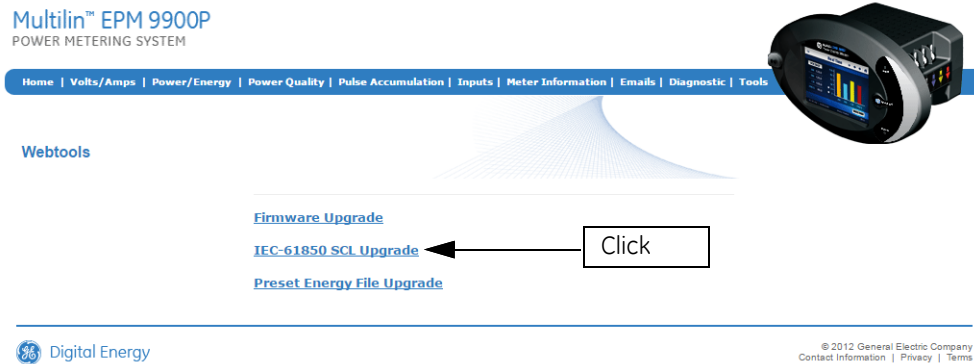

15. Click the **IEC-61850 SCL Upgrade** line. A screen will open asking for a username and password. If none has been set, you can use the default which is **anonymous** for both the username and password. Then click **OK**.

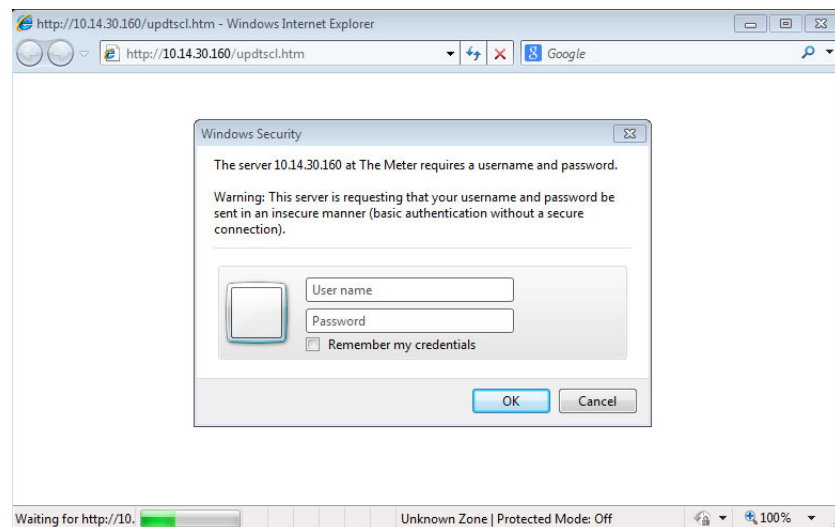

16. You will see the screen shown below. Click the Browse button to locate the .cid file you want to upload and click **Update SCL File** to upload it to the meter.

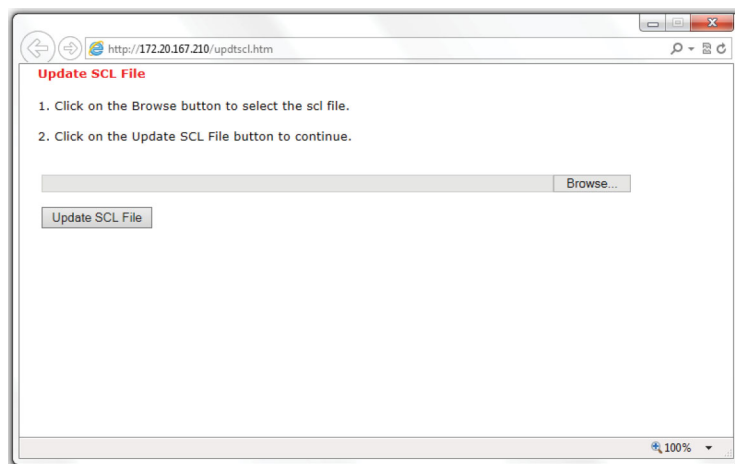



IMPORTANT NOTES!

• The IP address configured into the IEC 61850 Protocol Ethernet Network server with the GE Communicator software must be the same as the IP address configured in the .cid file. This is necessary to insure proper communication. If there is a communication problem it will be reported on the touch screen display’s IEC 61850 screen (see Chapter 6) and on the IEC 61850 Protocol Ethernet Network server’s Diagnostic screen. You access this screen by clicking Diagnostic from the left side of the Web server webpage, and then clicking the IEC- 61850 line. See the example screens that follow.

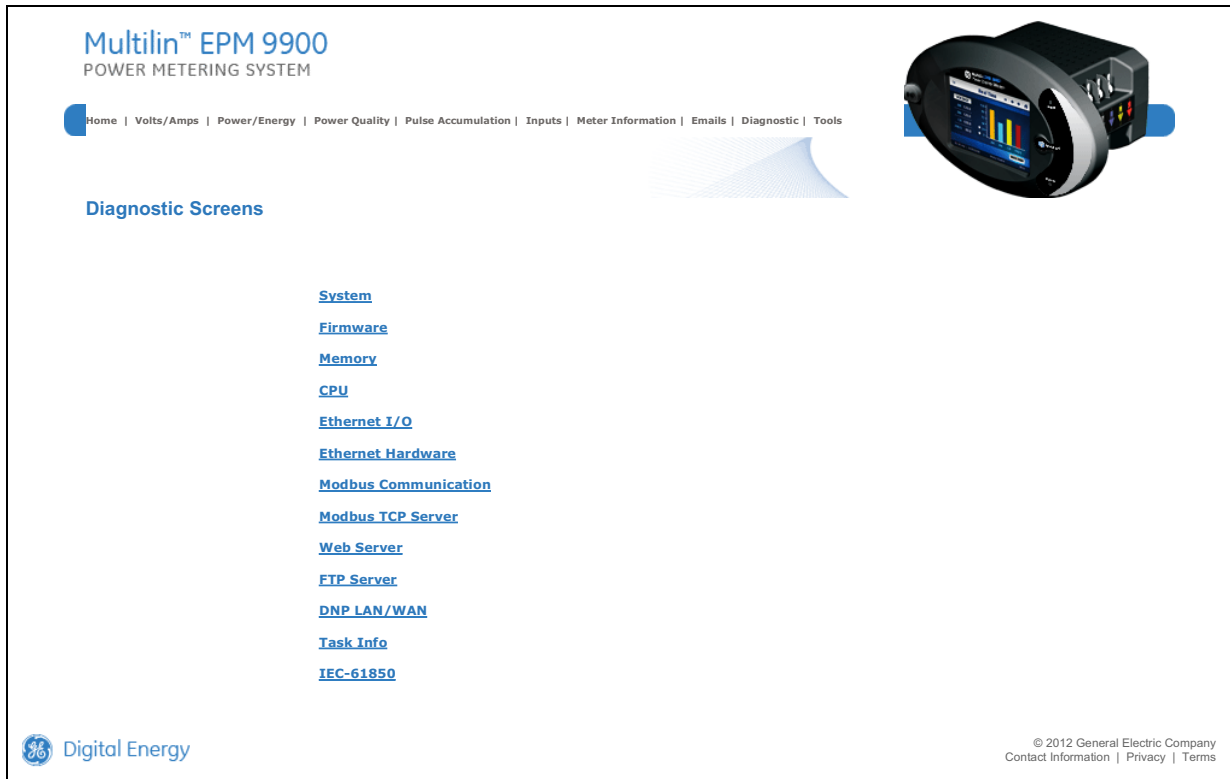

IEC-61850

IEC-61850
SERVER STATE
Server successfully initialized.
[The default's CID file has IP address mismatch.]

SERVER STATISTICS

TIMER:
Server initialization time (seconds): 0.931703

MEMORY:
Memory Allocated (bytes): 4534104
Memory Free (bytes): 421855
Number of Memory Allocated: 7420
Number of Memory Free: 6971
Total Memory Allocated (MBytes): 3.921746
Total Memory Allocated for all Data-set (bytes): 40869
Number of Data-set Success to Allocate: 2
Number of Data-set Fail to Allocate: 0

SCL PARSER MESSAGE

#001:
#002:
#003:
#004:
#005:
#006:
#007:
#008:
#009:
#010:
#011:*

STACK INDICATION

#001: ==>> Connect indication
#002: ==>> Abort indication
#003: ==>> Connect indication
#004: ==>> Connect indication
#005: ==>> Abort indication
#006: ==>> Abort indication
#007: ==>> Connect indication

- The sAddr fields in each object of the .icd file must be preserved when generating the .cid file. Do not change these, because they are used internally by the IEC 61850 server.
- Do not use non-ASCII characters in your .cid file (such as punctuation marks). Non-ASCII characters can cause the parsing of the .cid file to fail.
- If the uploaded .cid file has non-critical errors, the IEC 61850 Protocol Ethernet Network server will use the file anyway and will start up. Any errors can be seen in the Start Up log (see instructions below).
- If the uploaded .cid file has critical errors, the IEC 61850 will use the default .cid file (not the uploaded file) and it will start up. The errors can be seen in the IEC 61850 Diagnostic webpage, described on the previous page, and on the touch screen display's IEC 61850 screen (see Chapter 6).

B.3 Testing

You can use any IEC 61850 certified tool to connect to the EPM 9900P meter and test out the IEC 61850 protocol (see example screen below). There are numerous commercial tools available for purchase.

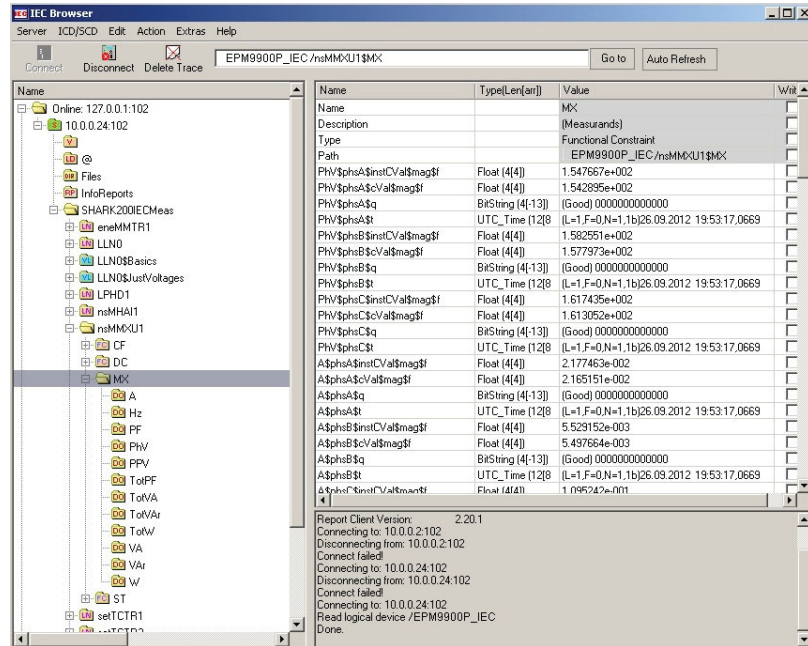

Multilin™ EPM 9900P

Appendix C: Resilient Cyber Security™

C.1 Introduction

The EPM 9900P offers an advanced security option - Resilient Cyber Security™, which enables role-based user accounts protected with an encryption key. Some of the features of Resilient Cyber Security™ are:

- An Admin user with full rights and a programmable password of up to 24 characters.
- Ten user IDs with passwords of up to 24 characters.
- Encrypted communication of sensitive data, such as passwords, usernames, roles, and rights.
- Customizing of the encryption key by the Admin user.
- Expiration programming of passwords and/or the encryption key by the Admin user.
- A security lock feature is available to prevent security from being disabled.

In addition to Resilient Cyber Security™, the meter's firmware provides security to ensure firmware integrity. The firmware is "signed" with a digital signature embedded in the firmware file/package.

- The digital signature is an encryption of a hash value computed over the firmware contents.
- The digital signature is decrypted by the firmware currently in the meter and the hash value is compared to make sure it is as expected.

Firmware is checked for integrity by the meter on startup and firmware update.

- On startup, if the firmware integrity check fails, the meter stays in Boot mode, and a System Failure message is displayed on the meter's screen and in the meter's status screen.
- During a firmware update, if the firmware integrity check fails, the meter will not accept the uploaded firmware file.

In addition to security, the meter has a sealing switch physical seals/lockouts, and an anti-tampering Events log that records all user logins and attempted logins, as well as other meter actions.

C.2 Programming Resilient Cyber Security



NOTE

The GE Communicator software is used to program the meter's Resilient Cyber Security. See the *GE Communicator Instruction Manual* for details.

Multilin™ EPM 9900P

Appendix D: Using SNMP

D.1 Overview

Simple Network Management Protocol (SNMP) is an Internet standard communication protocol used to manage devices over an IP computer network. It supports data collection and organization from managed devices, and enables modifications to the data in order to cause the managed device to change its behavior, e.g., for a switch to turn on.

SNMP is often employed in network monitoring of routers, switches, and large banks of servers, for example, in data centers. The results of that monitoring can then be conveyed to interested parties, for example, via a computer dashboard.

The EPM 9900P Meter supports SNMPv2 communication over either its standard or optional Ethernet ports, or over both ports. This capability lets the EPM 9900P seamlessly integrate into an existing SNMP managed network. For example, if SNMP is managing all of the servers in a data center, a EPM 9900P Meter can be installed at the bank of data servers, and configured so that power anomalies will be communicated to the user, enabling correction of the problem before it escalates and causes all of the servers to fail.

This appendix provides the specific SNMP elements as they relate to the EPM 9900P Meter's SNMP implementation.

D.2 Basics of SNMP

- An SNMP network links SNMP managers, also known as SNMP browsers, with remote devices, also known as SNMP agents. The SNMP managers can then access data from the remote devices and can also manipulate data in the devices. The managers and devices must all use the SNMP protocol. The EPM 9900P Meter with SNMP acts as an agent in an SNMP network.

- The SNMP protocol consists of standards contained in Request for Comments (RFCs). The SNMP standards set out the rules for the protocol's three main components - an application layer language, a database model, and data objects. The RFCs used in the EPM 9900P Meter's SNMP implementation are listed below in D.4: RFCs.
- The data used by the SNMP manager is defined as Managed Objects, each of which is represented by an object identifier (OID). The Managed Objects are divided into groups; each group consists of variables and tables. The details of the Managed Objects, groups, variables, etc. are defined in Management Information Bases (MIBs). The MIBs used with the EPM 9900P meter are explained below in D.3.1: MIBs.
- Communication between the SNMP manager and the meter takes place using standard Protocol Data Units (PDUs). The PDUs used with the EPM 9900P are explained in D.3.2: PDUs.
- One of the PDUs is traps, i.e., events/alarms that occurred in the meter. Once SNMP communication is enabled for one or both of the meter's Ethernet ports, traps can be configured to be sent to up to eight SNMP manager devices. The traps used by the EPM 9900P are explained in D.3.3: Traps.
- Security of the SNMP network is maintained by community fields, which act as passwords for the system.
- The EPM 9900P's SNMP implementation is compatible with off-the-shelf SNMP managers, e.g., iReasoning. The SNMP manager is used to set up the SNMP network and can also be used to view SNMP communications, such as traps.

D.3 SNMP Implementation

This section explains the MIBs, PDUs, and Traps used in the EPM 9900P Meter's SNMPv2 implementation.

D.3.1 MIBs

The EPM 9900P MIB groups are Enterprise MIB and Implemented Network MIBs, some of which are modifiable. You can download the meter's MIB file from GE's website.

Enterprise MIB

These are MIBs specific to the EPM 9900P Meter. There are 64 fixed items available from the meter:

One sec VAN	Block Window Average (BWA) VA
One sec VBN	BWA VAR
One sec VCN	BWA W
One sec VAB	BWA Pulse accumulation 1-8
One sec VBC	BWA Pulse accumulation Aggregation 1-4
One sec VCA	+W(Q14) Cumulative demand
One sec IA	-W(Q23) Cumulative demand
One sec IB	+W(Q14) Continuous Cumulative demand
One sec IC	-W(Q23) Continuous Cumulative demand

One sec INm	VAh
One sec Freq	+VARh(Q12)
One sec Voltage imbalance	-VARh(Q34)
One sec Current imbalance	+Wh(Q14)
One sec VA	-Wh(Q23)
One sec VAR	3 Sec Positive symmetrical Component Magnitude Voltage PN
One sec W	3 Sec Negative symmetrical Component Magnitude Voltage PN
One sec PF A	3 Sec Zero symmetrical Component Magnitude Voltage PN
One sec PF B	3 Sec Positive symmetrical Component Phase Voltage PN
One sec PF C	3 Sec Negative symmetrical Component Phase Voltage PN
One sec PF	3 Sec Zero symmetrical Component Phase Voltage PN
Pulse accumulation 1-8	3 Sec Zero symmetrical Component Ratio Voltage PN
Pulse accumulation Aggregation 1-4	3 Sec Negative symmetrical Component Ratio Voltage PN

Implemented Network MIBs

- **System Group** - provides information such as computer/equipment location, contact person, etc. The following MIB items from the System Group can be modified by an SNMP manager browser. These are the only modifiable items in the meter's SNMP configuration:
 - system.sysContact
 - system.sysName
 - system.sysLocation

Modifications to these items are stored in a file, so that the modified values will be retained through a meter reboot.
- **Interface Group** - provides information about the hardware interfaces, i.e. device name, type, MTU, Ethernet address, statistics etc.
- **Cidr Group** - provides information about the IP Routing Table. The Routing Table provides information on interface and IP address to send a packet to.
- **Internet Protocol (IP) Group** - provides interface information and statistics, which include the following Tables:
 - Internet Address Table: lists IP addresses, information and statistics.
 - Address Translation Table: ARP cache, i.e. IP to Ethernet address translation.
 - Default Router Table: default routes in routine table which is used when sending packets.
 - ICMP Statistics.
- **TCP Group** - provides TCP statistics as well as TCP socket listener and connection information.
- **UDP Group** - provides UDP statistics as well as UDP socket connection information.
- **SNMP Group** - provides SNMP statistics as well as capability to enable SNMP Traps.
- **Transmission Group** - provides device driver statistics for RS232 and Ethernet.

D.3.2 PDUs

PDUs, also referred to as “packets,” belong to one of two categories: PDUs sent from the SNMP manager to the meter, and PDUs sent from the meter to the SNMP manager.

PDUs sent from the SNMP manager to the meter:

- GetMessage (Message ID 0) - this retrieves the objects specified by the OIDs in the message.
- GetNextRequest (Message ID 1) - this retrieves objects which are next in lexical order in the MIB, to the objects specified by the OID in the message.
- GetBulkRequest (Message ID 5) - this retrieves a large number of objects specified by the OID in the message.
- SetRequest (Message ID 3) - this message modifies internal meter data specified by an OID and value in the message.

PDUs sent from the meter to the SNMP manager:

- Response (Message ID 2) - this sends values in response to a GetRequest, GetNextRequest, GetBulkRequest, or SetRequest command.
- Trap (Message ID 4) - this is sent in response to predefined events (see D.3.3: Traps).

D.3.3 Traps

The meter generates traps when certain things occur. The following conditions can be programmed to generate traps (see D.4: RFCs):

- Limit/Alarm State Change
- Digital Input Change
- Waveform Capture
- PQ (CBEMA) Event
- Relay Output Change of State
- Transient Capture

In addition, the meter generates network traps when the following conditions occur:

- Cold Start - this trap is generated when the meter has been initialized.
- Authentication Failure - this trap is generated when an SNMP message was received with an incorrect community field.

D.4 RFCs

The RFCs used in the meter’s SNMP implementation are:

- RFC 1213 - MIB-II
- RFC 4022 - TCP
- RFC 4113 - UDP
- RFC 4292 - IP Forwarding Table MIB (replaces RFC 1213, RFC 1354, RFCs 2096, 2011, and 2465)

- RFC 4293 - IP Group (replaces RFCs 2011, 2465, and 2466)

RFC	Groups	Tables	Description
1213	System	-	Provides system information; contact location, etc.
	Interfaces	Interfaces	Provides information regarding the meter's hardware interfaces, i.e. device name, type, MTU, Ethernet address, statistics, etc.
	Internet Protocol (IP) Group	-	Misc statistics; all tables in this group were deprecated
	SNMP Group	-	Provides SNMP statistic information
1650	etherStats	dot3Stats	Statistics for Ethernet interfaces
4022	TCP	TCP Connection Table	Provides information regarding connected TCP sockets
		TCP Listener Table	Provides information regarding listening TCP sockets
4113	UDP	UDP Endpoint Table	Provides information regarding UDP sockets
4292	IP Forwarding	IP Forwarding Table	Provides routing table information
4293	ipSystemStats	ipSystemStatsTable	Provides meter wide traffic for interface
	ipIfStats	ipIfStatsTable	Provides traffic statistics for each interface
	ipAddress	ipAddressTable	Provides address information about a meter's hardware interfaces
	ipNetToPhysical	ipNetToPhysicalTable	Provides IP to Ethernet address information
	ipDefaultRouter	ipDefaultRouterTable	Provides default router information
	icmpStats	icmpStatsTable	ICMP statistics
	USEC Basic	-	Contains information relevant to the user based security model for SNMPv2u. SNMPv2u was not widely implemented so SNMPv2u is disabled but is in this table for completeness.

RFC	TRAP	Description
1157	Cold	Meter startup
	Warm	Meter restarted (will not be generated by meter)
	Link Down	Interface closed (will not be generated by meter)
	Link Up	Interface reset (will not be generated by meter)
	Authentication Failure	Authentication failure (SNMPv1 or SNMPv2c)

The table below lists managed objects that have been deprecated; i.e. they are not being used currently and are included only for historical purposes, and the managed objects that are replacing the deprecated items in this implementation.

Deprecated Item	OID of Deprecated Item	Replacement Item	OID of Replacement Item	RFC of Replacement Item
atTable	mib-2.3	ipNetToMediaTable	mib-2.4.22	RFC1213
ipInReceives	mib-2.4.3	ipSystemStatsInReceives	ipSystem-StatsEntry.3	RFC4293
ipInHdrErrors	mib-2.4.4	ipSystemStatsIn-HdrErrors	ipSystem-StatsEntry.7	RFC4293

Deprecated Item	OID of Deprecated Item	Replacement Item	OID of Replacement Item	RFC of Replacement Item
ipInAddrErrors	mib-2.4.5	ipSystemStatsInAddrErrors	ipSystem-StatsEntry.9	RFC4293
ipForwDatagrams	mib-2.4.6	ipSystemStatsInForw-Datagrams	ipSystem-StatsEntry.12	RFC4293
ipInUnknownProtos	mib-2.4.7	ipSystemStatsInUnknownProtos	ipSystem-StatsEntry.10	RFC4293
ipInDiscards	mib-2.4.8	ipSystemStatsInDiscards	ipSystem-StatsEntry.17	RFC4293
ipInDelivers	mib-2.4.9	ipSystemStatsInDelivers	ipSystem-StatsEntry.18	RFC4293
ipOutRequests	mib-2.4.10	ipSystemStatsOutRequests	ipSystem-StatsEntry.20	RFC4293
ipOutDiscards	mib-2.4.11	ipSystemStatsOutDiscards	ipSystem-StatsEntry.25	RFC4293
ipOutNoRoutes	mib-2.4.12	ipSystemStatsOutNo-Routes	ipSystem-StatsEntry.22	RFC4293
ipReasmReqds	mib-2.4.14	ipSystemStatsReasm-Reqds	ipSystem-StatsEntry.14	RFC4293
ipReasmOKs	mib-2.4.15	ipSystemStatsReasmOKs	ipSystem-StatsEntry.15	RFC4293
ipReasmFails	mib-2.4.16	ipSystemStatsReasm-Fails	ipSystem-StatsEntry.16	RFC4293
ipFragOKs	mib-2.4.17	ipSystemStatsOut-FragOKs	ipSystem-StatsEntry.27	RFC4293
ipFragFails	mib-2.4.18	ipSystemStatsOut-FragFails	ipSystem-StatsEntry.28	RFC4293
ipFragCreates	mib-2.4.19	ipSystemStatsOut-FragCreates	ipSystem-StatsEntry.29	RFC4293
ipAddrTable	mib-2.4.20	ipAddressTable	mib-2.4.34	RFC4293
ipNetToMediaTable	mib-2.4.22	ipNetToPhysicalTable	mib-2.4.35	RFC4293
ipRouteDiscards	mib-2.4.23	inetCidrROuteDiscards	mib-2.4.24.8	RFC4292
ipForwardNumber	mib-2.4.24.1	ipCidrRouteNumber	mib-2.4.24.3	RFC2096
ipCidrRouteNumber	mib-2.4.24.3	inetCidrRouteNumber	mib-2.4.24.6	RFC4292
ipRouteTable	mib-2.4.21	ipForwardTable	mib-2.4.24.2	RFC1354
ipForwardTable	mib-2.4.24.2	ipCidrRouteTable	mib-2.4.24.4	RFC2096
ipCidrRouteTable	mib-2.4.24.4	inetCidrRouteTable	mib-2.4.24.7	RFC4292
tcp.tcpConnTable	mib-2.6.13	tcpConnectionTable	mib-2.49.19	RFC4022
		tcp.tcpConnTable	mib-2.49.20	
udp.udpTable	mib-2.7.5	udpEndpointTable	mib-2.50.7	RFC4113

D.5 Modbus Map Location of SNMP Settings

The following table shows where in the Modbus map the SNMP settings from the Device Profile are stored.

SNMP Settings			
Name	Settings	Description	Modbus
Device Profile			
SNMP enable	0 = all interfaces disabled 1 = enable interface 1 2 = enable interface 2 3 = both interfaces enabled	Enable/Disable SNMP service.	B3BCH
SNMP TRAPS enable	0 = all interfaces disabled 1 = enable interface 1 2 = enable interface 2 3 = both interfaces enabled	Enable/Disable TRAPS service.	7614H
SNMP TRAPS Manager ¹	0.0.0.0	1-8 IP addresses	75CCH – 75DBH

SNMP Settings			
Name	Settings	Description	Modbus
Device Profile			
SNMP TRAPS	Bit 15: 1 (Enabled) 0 (Disabled)(Default)	Enable/Disable traps for limits status changes	75F0H
	Bit 14: 1 (Enabled) 0 (Disabled)(Default)	Enable/Disable traps for digital input status changes	
	Bit 13: 1 (Enabled) 0 (Disabled)(Default)	Enable/Disable traps for waveform capture	
	Bit 12: 1 (Enabled) 0 (Disabled)(Default)	Enable/Disable traps for PQ(CBEMA) event	
	Bit 11: 1 (Enabled) 0 (Disabled)(Default)	Enable/Disable traps for relay output changes	
	Bit 10: 1 (Enabled) 0 (Disabled)(Default)	Enable/Disable traps for transient capture	
SNMP Agent Community Name	20 bytes "public" (default) padding with null (0x00)	Expected community name in input SNMP GET, GETN and SET messages.	75DCH - 75E5H
SNMP TRAPS Community Name	20 bytes "public" (default) padding with null (0x00)	Community name set in output SNMP trap messages	75E6H-75EFH

¹ The IP Address for traps manager set to 0.0.0.0 means that trap is disabled.

D.6 Setting up SNMP

This section shows how to set up SNMP for your meter, and how to set up your SNMP network to communicate with your meter.

D.6.1 Configure SNMP for the Meter

The meter's SNMP settings are configured using GE Communicator software. Note that the GE Communicator User Manual contains instructions for this, but the basic steps are given below.

1. Enable SNMP for either or both of the meter's Ethernet cards in the Services tab of the Advanced Network Settings screen.
 - To enable SNMP, select Card 1 Only, Card 2 Only, or Both Card 1 & 2.
 - Once SNMP is enabled, checkboxes for enabling traps for the selected cards are displayed. To enable traps for a card, check the card's box. Note that it is possible to enable traps for both cards.
2. Once you have enabled SNMP for one or both of the Ethernet cards, use the SNMP tab to configure SNMP settings for the meter.
 - Enter IP address(es) for one or more Trap Managers. These are the devices that will receive any traps messages from the meter.

- Check the boxes of the traps you want to generate.
- Enter a Community Name for both Agent and Traps.
 - The Agent Community name provides security by ensuring that the SNMP manager will only read (the manager’s Read Community name)/write (the manager’s Write Community name) from/to a managed object if it matches the Agent community name.
 - The Traps Community name provides security by ensuring that only traps that match the Traps Community name of the Agent are received by the SNMP manager.
- Click OK to save your settings.



The default for both community names is “public”.

The Agent community name should be the same as the SNMP Network Agent device’s Read and Write community name.

D.6.2 Set up SNMP Network

Use an SNMP manager application to make the settings that will let the meter work within the SNMP network. The example in this manual uses a free SNMP manager called SnmpB, but you can perform the same steps with whatever SNMP manager you currently use.

The following MIBs are required:

EtherLike-MIB – RFC 3635	IP-MIB – RFC 4293
IP-FORWARD-MIB – RFC 4292	EIG-MIB
IANA-RTPROTO-MIB – RFC 2932	SNMPv2-SMI – RFC 2578
IANA-RTPROTO-MIB – RFC 2932	TCP-MIB – RFC 4022
INET-ADDRESS-MIB - RFC 4001	UDP-MIB – RFC 4113

1. Open the SNMP manager application.
2. Click Options in the toolbar.
3. Click Manage Agent Profile.
4. In the General Properties section, enter:
 - A name for this SNMP profile.
 - The Agent device’s IP address.
 - Agent Port number 161.
 - The number of communication retries you want.
 - The number of seconds until a communication attempt times out.
 - Check SNMPv1 and SNMP v2 as the supported SNMP versions.
5. Click on the triangle to the left of the Profile name.
6. SNMPv1 and SNMPv2 are listed under the Profile name and the right side of the screen allows the user to enter information.

- Enter the Read and Write Community name. The name you entered for the Agent Community name (see D.6.1: Configure SNMP for the Meter) should be the same as the Read and Write Community name. Otherwise, reading/writing from/to the managed object will not be allowed by the Agent device.
- Click OK.



The default value for the Agent community name is “public”.

Although the SnmpB application doesn’t support this, Traps Community names can also be configured for the SNMP Manager to match the meter’s Traps Community name (see D.6.1: Configure SNMP for the Meter).

7. You can copy the MIBs mentioned earlier in this section into the directory that the SNMP manager application (in this example, SnmpB) uses, or you can set up a directory for the MIB files in this way:
 - Click Options in the SnmpB tool bar.
 - Click the Preference box in the pull-down menu.
 - Click Modules in the box on the left side and click Add.
 - Type in your new path in one of the “type new path here” lines.
8. Click OK.
9. Load the new MIBs to the SNMP network in this way:
 - Click the Modules tab.
 - The available MIBs are listed in the box on the left, and the ones that have been loaded are shown in the box on the right. Use the arrows between the boxes to move load MIBs (or unload the MIBs), by moving them into (or out of) the loaded MIBs box.

D.6.3 Examples

This section gives an example of viewing meter readings and traps. Again, these examples were generated using the SnmpB application, but you can use any SNMP manager application to view meter and SNMP network communications/status. These examples assume that the steps listed in D.6.2: Set up SNMP Network, on page D-9 have been followed and the EIG-MIB is loaded into the SNMP network.

Retrieving a Meter Reading

1. In the SnmpB application, click the Tree tab and expand it, so that you are seeing the **EIG folder>n×1500P folder>mes and traps** folders.
2. Click on the mes folder and right-click it.
3. Select Walk to retrieve all of the readings in the mes folder.
4. Right-click on one of the readings under the mes folder.
5. Select Get. The reading is shown on the right side of the screen.

Retrieving Traps

1. Click the Traps tab. Any traps sent to the device’s IP address are displayed.
2. Click on a trap to view details about the trap, which are displayed in the Trap Info box in the lower right of the screen.



NOTE

If traps are enabled in only one card, the traps will be sent out over that one card. If both cards are enabled, then the trap will be sent over the card which has the same subnet address as the trap manager. If no card is on the same subnet with the trap manager, the trap will be sent over a gateway (if one is configured).

Displaying All MIBs (Walking the MIBs)

To display all of the system MIBs, using the SnmpB application as an example:

1. Click the Tree tab, click SNMPv1 or SNMPv2 (whichever your system is using) then click MIB Tree > iso
2. Right-click on iso.
3. Click Walk. The MIB values are shown in the box on the right.

Reading from and Writing to the EIG SNMP File

The only information which can be written to the EIG SNMP file is the system contact, system name, and/or system location. This section shows how to read that information first, and then how to write new information into the file.

To read from the file, using the SnmpB application as an example:

1. From the MIB Tree, click **iso>org>dod>internet>mgmt>mib-2>system**.
2. Select either sysContact (system contact), sysName (system name), or sysLocation (system location). Right-click on the item you selected and the defaults of Manager in Office (sysContact) Power Quality Meter (sysName), and Meter in the field (sysLocation) are shown on the right side of the screen.

To write to the file:

1. From the MIB Tree, click **iso>org>dod>internet>mgmt>mib-2>system**.
2. Select either sysContact (system contact), sysName (system name), or sysLocation (system location) and right-click on it; select Set.
3. The Set window opens. Type a new setting inside the Value field and press OK. This setting will be kept even after meter reset or power down/up.

Multilin™ EPM 9900P

Appendix E: Synchrophasor Systems

E.1 Overview

Synchrophasor systems use high speed phasor readings taken from multiple locations on the electrical grid and synchronized to a highly accurate time source. Synchrophasors are used to analyze electrical grid performance. They provide wide-area situational awareness for system operators, giving them tools to adjust and improve power stability by letting them:

- Determine stress points in the transmission system.
- View phase divergence in different parts of the system.
- Detect islanding.
- Address power system weaknesses to ensure reliable power.

This appendix explains the history, functionality, and applications for synchrophasors. It also explains the EPM 9900P meter's synchrophasor support (see E.5: EPM 9900P Meter's Synchrophasor Support). Appendix F gives instructions for programming the meter's synchrophasor function.

E.2 History of Synchrophasors

The synchronized phasor measurement in substations was first standardized in 1995 in the IEEE 1344 standard. This standard was improved upon over the years and in 2012 IEC 61850-90-5 was published. IEC 61850-90-5 presented a way to migrate earlier synchrophasor standards to the IEC 61850 architecture, in order to take advantage of faster sampling and data transmission rates, as well as improved Cyber security.

However, the idea behind synchrophasors arose in the 1970s, when the use of computers to implement protection and control functions was in the early stages of its development. The perceived need was the development of a measurement of the fundamental quantities of voltage and current. Then protection and control algorithms could be based on that measurement.

The first step toward synchrophasors was when Dr. Arun Phadke of American Electric Power proposed using a discrete Fourier transform (DFT) function to compute a “phasor” view of voltage and current¹. When this calculation was implemented in a minicomputer, it was noted that the “phasor” computed by the DFT would rotate over time. The possibility of synchrophasors developed with the realization that the phasor measurement could be synchronized to absolute time throughout the power grid, giving a wide-area view of the actual conditions throughout it. Though this inspired idea took place in 1979, it took roughly eight years before the necessary high-accuracy time synchronization technology would arrive, in the form of GPS. It was then possible to measure the phasors across the grid at a synchronized time. That is when synchrophasors became an invaluable tool for electrical grid analysis.

1. PHADKE, Arun & BI, Tianshu. (2018). Phasor measurement units, WAMS, and their applications in protection and control of power systems. *Journal of Modern Power Systems and Clean Energy*. 6. 10.1007/s40565-018-0423-3

E.3 Basics of a Synchrophasor System

A typical synchrophasor system consists of:

- Multiple phasor measurement units (PMUs)
- One or more phasor data concentrators (PDCs)

- A communication framework for transmitting data
- A control, monitoring, or visualization application

From its specific location on the electrical grid, each PMU estimates phasor (magnitude and phase angle of voltage and current) and related data that is accurately synchronized to a common time source. The time-synchronized estimated phasor is called a synchrophasor. Multiple PMUs transmit the synchrophasors and related data to a PDC, which aggregates and time-aligns the data for real time and post analysis. Local PDCs receive data from multiple PMUs inside a substation, and another PDC, referred to as the SPDC, receives the data from multiple local PDCs.

E.3.1 Synchrophasor System Requirements

The most recent synchrophasor measurement standards are IEEE C37.118.1-2011 and its modification IEEE C37.118.1a-2014. Synchrophasor communication requirements are given in IEEE C37.118.2-2011. The EPM 9900P meter's PMU functions meet these requirements.

PMU Hardware Requirements

Time Synchronization

As mentioned earlier, a synchrophasor system requires a highly accurate time source for time synchronization of measurements. IRIG-B and PTP are the usual time sources in synchrophasor systems. The EPM 9900P meter supports both of these time sources.

The time accuracy of the time source and PMU must meet the synchrophasor standard's requirements. For instance, a time error of either +/- 26 μ s for a 60 Hz system or +/- 31 μ s for a 50 Hz system will cause a phase error of 0.51 degrees. This phase error will cause a Total Vector Error (TVE) of 1%, which is the limit for TVE in some of the standard's requirements. The synchrophasor standard highly recommends that the time source should have a time accuracy at least 10 times better.

Equipment Specification and Resilience

Power supply as specified in the C 37.90 standard:

- DC contact rating threshold
- Transient suppression requirements
- Debounce requirements

PMU Software Requirements

Data Classes and Characteristics

IEEE C37.118.1 standard defines two classes of synchrophasors that can be streamed or captured by a PMU. These classes are known as:

- The P Class or Protection Class Synchrophasors – this class utilizes a 2-cycle “triangular” data filtering window. Given the small window size, a synchrophasor or two can be computed during most fault cases and subsequently be used in a

double or triple ended fault location (see Figure E-1 below). P Class synchrophasors can be emitted at rates of 120 measurements/sec or higher.

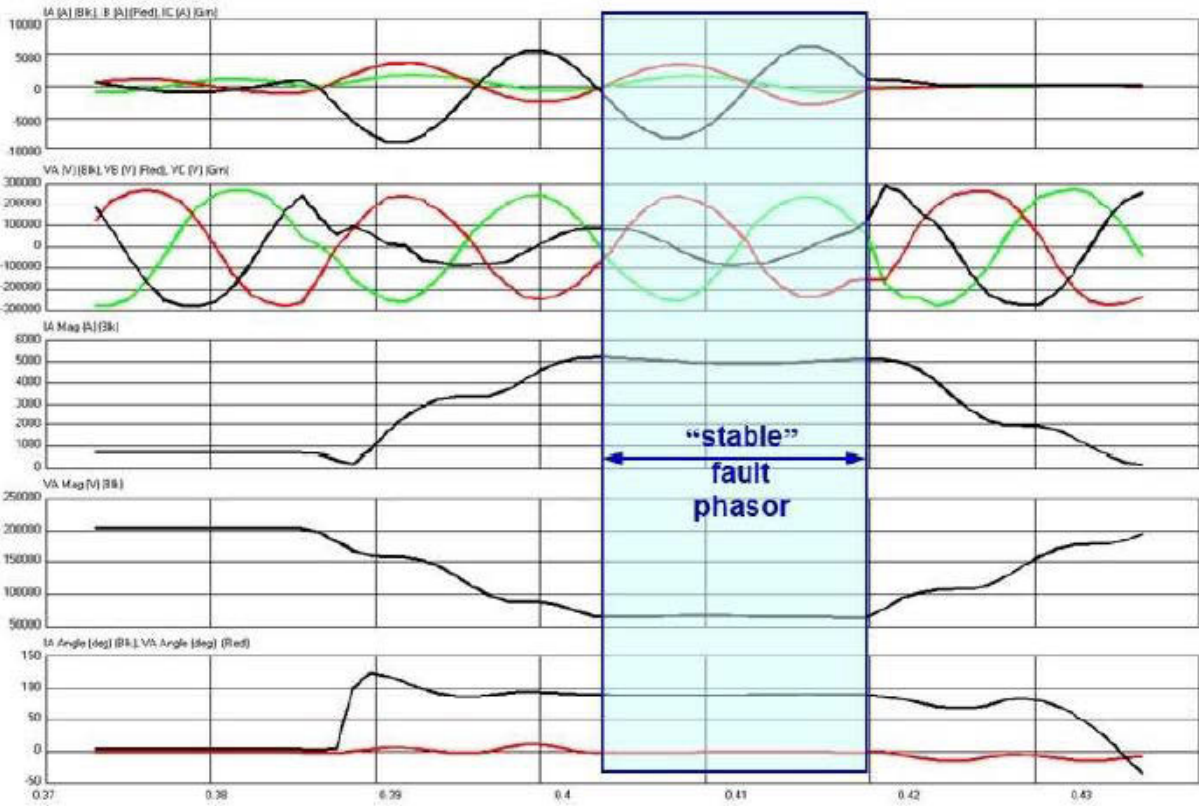

Figure E-1: Use of P Class Synchrophasors for Fault Calculation

- The M Class or Measurement Synchrophasors – the M Class synchrophasor integrates sample values over a 7-cycle window. Additionally, the M Class provides a bandpass filter to eliminate frequency components around the nominal frequency. With such a large integration window, an M-Class Synchrophasor will NOT see fault quantities. Moreover, the M-Class measurements will tend to “average” over the fault window. The M Class can be emitted at rates up to 60 measurements per second. Figure E-2 shows a sample comparison of IEEE C 37.118.1 “P” and “M” class data for 120 frames and 60 frames per second, respectively, from field measurements.

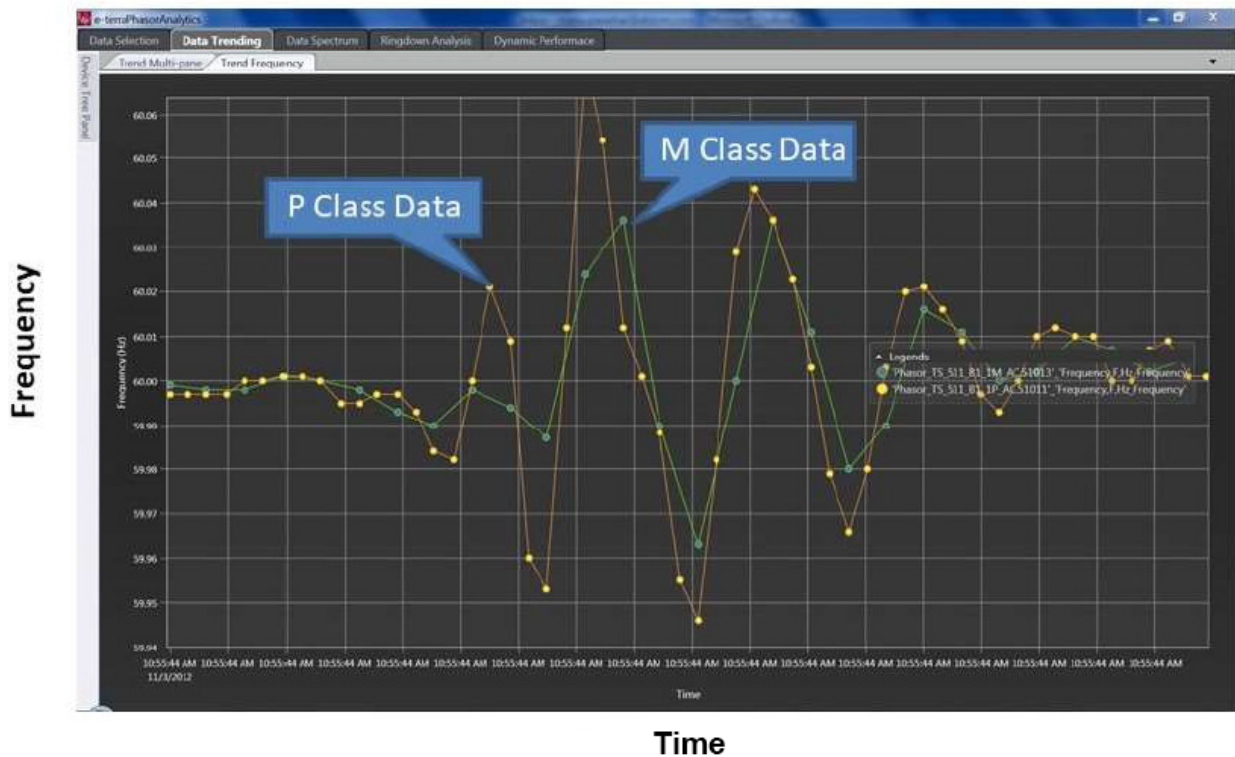

Figure E-2: P and M Class Data Comparison

Auto Stream on Power Up

In secure installations in which data communication is only allowed outbound, the PMU needs to be able to automatically transmit the message Configuration Frame and then start streaming data, immediately on startup. This is configurable through a setting in the PMU device. (see F.2.2 Step Two - Enable Synchrophasors). Any change in configuration will result in the setting of the Configuration Change flag in the streaming message, a re-transmission of the Configuration Frame containing the changed data, and a restart of data streaming.

Communication Options

IEEE C37.118.2, defines the most frequently used communication protocol for synchrophasors. C37.118.2 can work with either TCP (packet re-transmission on failure to acknowledge) or UDP (no re-transmission on lost packets). The EPM 9900P meter as PMU adheres to the IEEE C37.118.2 standard. It does not support IEC 61850 protocol in its synchrophasor implementation.

E.4 Capabilities/Benefits of a Synchrophasor System

As the electrical grid becomes more complex and more based on inverter sources of power, its fragility increases. An example of this is a recent frequency disturbance in California that resulted in over a Giga-Watt of inverters taking themselves offline. A 99 kV line in Southern California had tripped and this resulted in a power outage in the southern part of the state. Synchronized measurements of the event enabled rapid analysis of the causes of the outage.

The tripping of a line connected to a generator can cause the acceleration of the generator into instability. Being able to monitor the acceleration of the generator, allows a system operator to detect the incipient over-speed and take corrective action immediately, before the problem escalates. Synchrophasor measurements enable such monitoring. Some benefits of a synchrophasor system are reliability, constraint relief, stability, and post-event analysis.

Some of the reliability benefits are:

- Situational awareness - the data streamed by a synchrophasor system provides wide-area visibility of the electrical grid which can't be matched by systems such as SCADA, which can't supply the high-speed dynamic measurements that PMUs can.
- Early warning of instability - monitoring the synchrophasor data provides advance warning of power system stability issues.
- Oscillation detection - low frequency oscillation threatens the reliability of the electrical grid. Synchrophasor data analysis can determine if oscillation exists on the grid, if it will negatively impact the grid, and the location and type of oscillation¹.
- Synchrophasor data enables post -event analysis, which in turn leads to better planning to address, and steps to mitigate, power system events.
- Islanding recovery - when a distributed generator delivers power to a location that is no longer being powered by the electrical grid, an islanding condition has occurred. Synchrophasors enable detection of islanding that leads to quick response to address this critical and unsafe (for both people and machinery) situation.

One of the constraint relief benefits is:

- Improved congestion management - congestion occurs when areas of the grid are receiving less power than they should. Synchrophasors help to detect and address this situation by providing the data needed to determine the cause of the congestion, as well as helping system operators to integrate renewables, such as wind power, into the grid to provide additional sources of power

1. "Using Synchrophasor Data for Oscillation Detection", North American Synchrophasor Initiative, September 2017.
https://www.naspi.org/sites/default/files/reference_documents/crstm_oscillation_detection_20180129_final.pdf

The stability benefits are:

- Voltage stability - maintaining stable voltage after a grid disturbance is essential to avoid cascading failure. Synchrophasor data provides real time monitoring of the grid that gives system operators the information they need to maintain voltage stability and prevent the grid disturbance from becoming a catastrophic power outage¹.
- Impact of renewables on grid stability, specifically visibility of wind and solar interconnection - synchrophasor data provides both real time monitoring of frequency and detection of oscillation and low damping conditions.

The system analysis benefits include:

- Post-event analysis - in addition to real time data, the synchrophasor data is extremely useful post-event, for conducting forensic analysis.
- Model validation – e.g. impact of renewables on the electrical grid. The ability of synchrophasors to provide high-speed and localized data make them ideal for power system model validation studies. These models are important for utilities' long-term planning.

1. USMAN, M.U., FARUQUE, M.O. Applications of synchrophasor technologies in

power systems. J. Mod. Power Syst. Clean Energy 7, 211–226 (2019).
<https://doi.org/10.1007/s40565-018-0455-8>

E.5 EPM 9900P Meter's Synchrophasor Support

The EPM 9900P meter with Firmware version 1.0 and later and V-Switch keys 4-6 meets the IEEE C37.118.1a-2014 Class P and M standard, acting as a PMU that provides real time synchrophasor outputs. Features of the meter's PMU functions include:

1. Provides the following data:
 - Individual voltage/current phasors (VA, VB, VC, IA, IB, IC)
 - Symmetrical components phasors (V0, V1, V2, I0, I1, I2)
 - Frequency
 - ROCOF (Rate of change of frequency)
 - Built-in high-speed digital inputs
 - Analog:
 - Fundamental Power:
 - Watt total and per phase
 - VA total and per phase
 - VAR total and per phase
 - Displacement power factor: total and per phase
2. Supports both P and M classes
3. Data Frame Rates for 50 Hz: 10/25/50 frames per second; for 60 Hz: 10/12/15/20/30/60 frames per second.
4. Data Format: Configurable Float or Integer, Polar or Rectangular
5. Time Sync Standard: IRIG-B or IEEE 1588 PTPv2
6. Supports Ethernet or Fiber over Ethernet with:
 - TCP communication for header, configuration, and command
 - UDP communication for data, including unicast, broadcast, and multicast
7. Number of Sessions: Up to two clients can communicate with the EPM 9900P meter/PMU at one time, i.e., send requests or commands via TCP. In Unicast mode only, up to two clients can receive the PMU data via UDP.
8. Supports auto-sending of data upon startup.

See Setting up the PMU for PMU programming instructions.

Multilin™ EPM 9900P

Appendix F: Setting up the PMU

F.1 Overview

As explained in E.5 EPM 9900P Meter's Synchrophasor Support, the EPM 9900P meter with Firmware version 1.0 and later and Software Options D, E, F meets the IEEE C37.118.1a-2014 Class P and M standard, acting as a PMU that provides real time synchrophasor outputs. This appendix explains how to set up the meter as a PMU. (For details on Synchrophasor Systems, see Synchrophasor Systems.)

F.1.1 Details of the EPM 9900P Meter's Synchrophasor PMU Implementation

The EPM 9900P meter allows synchrophasor communication on either of its two Ethernet ports (only one port at a time can be enabled for synchrophasors). The header (outgoing from the meter), configuration (outgoing from the meter) and command (incoming from another device) frames will be sent/received over TCP/IP protocol and the data (outgoing from the meter) frame will be sent over UDP.

The user can configure the meter's listening port for TCP/IP communication (by default the port is 4712) and for UDP communication (by default the port is 4713). The user needs to configure whether the data frame will be sent to unicast, multicast, or broadcast addresses and either local or global broadcast address types.

- If unicast is selected, up to two clients (destination) can simultaneously receive the same data frame from the PMU over UDP. The user needs to program two UDP destination IP address and listening ports.
- If multicast is selected, the user needs to program the multicast address and one UDP port. In multicast, multiple destinations can simultaneously receive the same data frame from the PMU over UDP.
- If broadcast is selected, the user needs to select between local or global (255.255.255.255) broadcast address and multiple destinations can simultaneously receive the same data frame from the PMU over UDP.

The user can configure the meter to send out synchrophasor data automatically, as soon as the meter starts up.

The client (normally a PDC device) is the device that sends the command via TCP/IP to “start sending synchrophasor data”. That client can also send other commands, including “stop sending synchrophasor data”. TCP disconnection will not stop the synchrophasor data frame from being transmitted over UDP.

F.2 Programming the Meter’s Synchrophasor Feature

These are the steps to take to configure the EPM 9900P Power Quality meter as a PMU. Once configured as a PMU, the meter can operate in a synchrophasor system, reporting synchrophasor data to a PDC. Note that this procedure assumes GE Communicator v5.00.0089 or higher, meter firmware version 20 or higher, and meter Software Options D, E, F.

1. Step One - program time synchronization method - either IRIG-B or IEEE 1588 PTPv2.
2. Step Two - enable synchrophasors.
3. Step Three - program the meter’s nominal frequency.
4. Step Four - program the meter’s phasor measurement unit settings.
5. The remainder of the programming will take place in your synchrophasor system.



Steps one through three are accomplished through the meter’s programmable settings, which necessitates updating and resetting the meter. Step four uses the **Tools > Phasor Measurement Settings** screen, which can be changed dynamically, without changing the programmable settings or resetting the meter.

F.2.1 Step One - Select Time Synchronization Method

1. Connect to the meter using GE Communicator software.
2. In the Device Status screen, make sure the meter’s Software Options are D, E, F.
3. Click the Profile icon in the Icon bar.
4. Select the time source for time synchronization by clicking **General Settings > Time Settings**.
5. Under Clock Synchronization Source, select either IRIG-B or IEEE 1588 PTP.
 - If you selected IRIG-B, click OK and then proceed to Step Two.
6. If you selected IEEE 1588 PTP, a new button, Configure PTP, is displayed.
7. Click the Configure PTP button.
 - If this is the first time you are setting up IEEE 1588 PTP (or if it was not previously set up correctly), the message “Do you want to load the default values for IEEE 1588 PTP?” will be displayed. Click Yes to continue.
8. The Advanced Network Settings screen opens, displaying the Services tab.
9. Make sure that IEEE 1588 PTP is selected for the Network Time Sync and that Disabled is set for the IEEE 1588 PTP Master. Then click the IEEE 1588 PTP tab.

10. In the Slave settings tab, make the following settings:
 - Delay Request/Response Send Rate: select the time delay you want from the pull-down menu.
 - Best Master Clock Timeout Multiplier - select from the pull-down menu the amount to multiply the master clock's timeout by, enabling a longer period before timeout.
 - The Master Clock ID list is used when there are multiple master clocks in the system.
 - The clocks are listed in order of priority, e.g. if the first master clock is not accessible, the second will be used, and so on.
 - The order is set when the master clocks are added - the first one added is first, the second added is second, etc.
 - You can Add a new master clock (Add button) or edit an existing master clock's ID (click on the master clock ID and click Edit button). If you want to delete a master clock from the list, click on it and click Remove.
11. Click the Services tab and proceed to number 3 in the next section.

F.2.2 Step Two - Enable Synchrophasors

1. Click **General Settings > Communications**.
2. If there are two Ethernet cards in the meter you will see two Advanced Settings buttons; otherwise, there will just be one. Click an Advanced Settings button.
3. In the Services tab (the first tab that opens in the Advanced Settings screen), select either Card 1 Only or Card 2 Only in the Synchrophasor (PMU) setting, to specify which card will handle Synchrophasor traffic in the meter. You can use either card, but only one card at a time can be set for Synchrophasors.
4. Click the Synchrophasor (PMU) tab. This screen lets you make communication settings for the meter/PMU and the client/PDC.
5. Make the following settings:
 - For Service Class, select either M Class or P Class. Your selection depends on your synchrophasor system - the meter supports both classes (see PMU Software Requirements, for a detailed explanation of classes). This field is required.
 - Check the Auto Send Data box to have the PMU send data automatically on startup. This setting depends on your system requirements. If you do not select auto send, the meter will wait for a request for data from the client/PDC on startup.
 - In TCP Port, enter the TCP port used by the meter to receive synchrophasor commands. This field is required.
 - In UDP Port, enter the UDP port used by the meter to send synchrophasor data. This field is required.
 - In UDP Destination Port 1, enter the client's/PDC's UDP port used to receive synchrophasor data from the meter. This field is required.
 - In UDP Destination IP Address 1, enter the client's/PDC's IP address. This option is only available in Unicast mode.

- In Unicast mode only, you can also set a second UDP Destination Port and Destination IP Address, to be used by a second client/PDC. In other modes, these fields cannot be used.
 - In UDP Destination Address, select from Broadcast, Multicast, and Unicast.
 - If you select Broadcast, then select either Local Broadcast or Global (255.255.255.255) from the Broadcast Address Type field.
 - If you select Multicast, enter the UDP Multicast Address in its field.
 - If you select Unicast, enter the UDP destination IP address 1 in its field. You also have the option to enter a second UDP destination address in Unicast mode - use the UDP destination port 2 and IP address field 2 to set up a second client that can communicate with the meter/PMU.
6. Click OK to save your settings and close the Advanced Network Option Settings screen.

F.2.3 Step Three - Program the Meter's Nominal Frequency

The next step is to program the frequency for the meter.

1. From the meter's Device Profile menu, click **Power Quality and Alarm Settings > EN50160/IEC 61000-4-30**.
2. The EN50160/IEC 61000 screen is displayed. Click the General Settings tab to see the screen below.
3. Select your meter's frequency - 50 or 60 from the pull-down menu.
4. Click OK.
5. The Device Profile part of the PMU configuration is complete. You can either:
 - Click the Update Device button at the bottom of the Device Profile screen and wait until the meter is back online.
 - Click the Save button at the bottom of the Device Profile screen and save the settings you have made. Then when you are ready to update your device, click the Load button in the Device Profile screen and select the saved Device Profile. You can then update the meter with the new device profile settings.

F.2.4 Step Four - Program the Meter's PMU Settings

Once the meter has been updated with the PMU settings made in steps one through three and the meter is running, you will configure additional settings for the EPM 9900P Power Quality meter acting as a PMU.

1. From the top of the Main screen, click **Tools > Edit Phasor Measurement Unit Settings**.
2. The Phasor Measurement Unit Settings screen shows the following key items:
 - Meter ID
 - Meter's PMU settings (from Step Two)
 - Any errors
 - PMU Status
 - Clock Sync Method
 - Auto Send Status

3. The Phasor Unit Measurement Settings screen has a top portion and three tabs. With the exception of the service class field, the settings on this screen are transmitted via the configuration and header in the meter's PMU communications. These settings enable a client, such as a PDC, to distinguish between and interpret the synchrophasor data from different PMUs.
4. The top of the screen displays the PMU settings you already made for Nominal Line Frequency, Service Class, TCP Port, and UDP Port. The new settings on the top of the screen are:
 - Station name - this field is read only. It is the meter designation that was configured in the meter's device profile Labels screen (**General Settings > Labels**).
 - Data Stream ID - enter any number from 1 to 65534. This number is used to identify the synchrophasor data stream coming from the meter. It enables the PDC to know which meter/PMU is sending the data. The number you enter depends on the other devices in your synchrophasor system. If you already have devices with data stream IDs of 1-20, then you can enter anything between 21 and 65534. Ensure a unique number is entered; don't use a number already assigned to a device in the synchrophasor system.
 - Frequency Data Type - select between Integer and Floating Point from the pull-down menu. Integer does not have decimal points, floating point does. Decimals give a reading more precision, if that is what your synchrophasor application requires. You can also use conversion factors or multipliers for greater resolution - see the Phasor List and Analog Values tabs descriptions below.
 - Analog Data Type - select between Integer and Floating Point from the pull-down menu.
 - Phasor Data Type - select between Integer and Floating Point from the pull-down menu.
 - Phasor Coordinate System - select between rectangular and polar. Rectangular will provide horizontal and vertical dimensions; polar will provide magnitude and angle dimensions. Note that most users will select polar, but the standard and the EPM 9900P meter support either.
 - Data Rate - choose the data rate from the pull-down menu. The choices you have are determined by your frequency rate (50 Hz or 60 Hz). The data rate is the reporting rate in frames per second.
 - Report Type - check the box(es) for the PMU data you wish to transmit. Note that Individual Phasors is always selected. The other choices are:
 - Analog (Watt, VAR, VA, PF)
 - Symmetrical Components (V0, V1, V2, I0, I1, I2) zero/positive/negative
 - Digital Inputs (the meter's high-speed digital inputs)
5. Use the tabs to enter channel names and other settings for the phasors, and if selected for reporting, the analog outputs and digital inputs. It is only possible to make settings for the selected reports.
 - Phasor List tab: displays the phasor channel names and, if applicable, the conversion factor.
 - You can change channel names.

- If the 16-bit integer is selected for the phasor data type, the Multiplier field can be used to create a reading with greater resolution. The reading value will be divided by the conversion factor entered. It is not possible to change this field if the phasor data type is floating point.
 - Analog Values tab: displays the analog value channel names and, if applicable, the multiplier.
 - You can change channel names.
 - If the 16-bit integer is selected for the analog values data type, the Multiplier field can be used to create a reading with greater resolution. The reading value will be multiplied by the number entered, e.g. .001. It is not possible to change this field if the analog values data type is floating point.
 - Digital Inputs tab: displays the programmed channel names and state. The fields in this tab are not editable. The channel name and state assignments are made in the meter's device profile high-speed inputs setting (**Power Quality and Alarm Settings > High Speed Inputs**).
6. The bottom of the screen displays status information:
 - PMU Status: whether the PMU is enabled, configured properly and transmitting data.
 - Clock Sync Status - IRIG-B or IEEE PTP, determined by the setting made in F.2.1 Step One - Select Time Synchronization Method.
 - Auto Send Status - Enabled or disabled, depending on the setting made in F.2.2 Step Two - Enable Synchrophasors.
 7. If there are errors in the PMU settings, e.g. if Time sync is not set, error messages will be shown at the top right of the screen.
 8. The buttons at the bottom are used as follows:
 - Factory Defaults - load the factory default settings for all the screen fields.
 - Update Device - upload the new settings to the meter. The meter will use these settings when it is acting as a PMU. After Update Device is selected, a message screen with a countdown timer will appear as the meter settings are being uploaded. The update process will take 60 seconds.
 - Retrieve - retrieve the settings that are currently in the meter.
 - Close - close this screen.
 9. You have now finished programming the meter as a PMU. GE VERNOVA Grid Solutions recommends that a PDC is used to poll the meter/PMU to get the PMU configuration details. These will be necessary in order to correctly interpret the data that the meter-PMU transmits.

Multilin™ EPM 9900P

Appendix G: Manual Revision History

G.1 Release Notes

MANUAL	GE PART NO.	RELEASE DATE
GEK-113916	1601-0240-A1	September 2016
GEK-113916A	1601-0240-A2	October 2016
N/A	1601-0240-A3	January 2022

G.1.1 Major Updates

CHAPTER	DESCRIPTION
2	Updated for new features SNMP, Security, IEC 1588, PMU
5	Updated for IEC 1588
6	Added SNMP, Security
Appendices	Added sections for CyberSecurity, SNMP, Synchrophasor and PMU

For further information on the updates included in this release of the EPM 9900P HIGH PERFORMANCE POWER QUALITY METERING SYSTEM – INSTRUCTION MANUAL, please refer to the latest release notes online.

Multilin™ EPM 9900P

Glossary: Glossary

0.2 Second Values:

These values are the RMS values of the indicated quantity as calculated after approximately 200 milliseconds (3 cycles) of sampling.

1- Second Values:

These values are the RMS values of the indicated quantity as calculated after one second (60 cycles) of sampling.

Alarm:

An event or condition in a meter that can cause a trigger or call-back to occur.

Annunciator:

A short label that identifies particular quantities or values displayed, for example kWh.

Average (Current):

When applied to current values (Amps) the average is a calculated value that corresponds to the thermal average over a specified time interval.

The interval is specified by the user in the meter profile. The interval is typically 15 minutes. So, Average Amps is the thermal average of Amps over the previous 15-minute interval. The thermal average rises to 90% of the actual value in each time interval. For example, if a constant 100 Amp load is applied, the thermal average will indicate 90 amps after one time interval, 99 amps after two time intervals and 99.9 amps after three time intervals.

Average (Input Pulse Accumulations):

When applied to Input Pulse Accumulations, the “Average” refers to the block (fixed) window average value of the input pulses.

Average (Power):

When applied to power values (Watts, VARs, VA), the average is a calculated value that corresponds to the thermal average over a specified time interval.

The interval is specified by the user in the meter profile. The interval is typically 15 minutes. So, the Average Watts is the thermal average of Watts over the previous 15-minute interval. The thermal average rises to 90% of the actual value in each time interval. For example, if a constant 100 kW load is applied, the thermal average will indicate 90 kW after one time interval, 99 kW after two time intervals and 99.9 kW after three time intervals.

Bit:

A unit of computer information equivalent to the result of a choice between two alternatives (Yes/No, On/Off, for example).

Or, the physical representation of a bit by an electrical pulse whose presence or absence indicates data.

Binary:

Relating to a system of numbers having 2 as its base (digits 0 and 1).

Block Window Avg. (Power):

The Block (Fixed) Window Average is the average power calculated over a user-set time interval, typically 15 minutes. This calculated average corresponds to the demand calculations performed by most electric utilities in monitoring user power demand. (See Rolling Window Average.)

Byte:

A group of 8 binary digits processed as a unit by a computer (or device) and used especially to represent an alphanumeric character.

CBEMA Curve:

A voltage quality curve established originally by the Computer Business Equipment Manufacturers Association. The CBEMA Curve defines voltage disturbances that could cause malfunction or damage in microprocessor devices. The curve is characterized by voltage magnitude and the duration which the voltage is outside of tolerance. (See ITIC Curve.)

Channel:

The storage of a single value in each interval in a load profile.

Cold Load Pickup:

This value is the delay from the time control power is restored to the time when the user wants to resume demand accumulation.

CRC Field:

Cyclic Redundancy Check Field (Modbus communication) is an error checksum calculation that enables a Slave device to determine if a request packet from a Master device has been corrupted during transmission. If the calculated value does not match the value in the request packet, the Slave ignores the request.

CT (Current) Ratio:

A Current Transformer Ratio is used to scale the value of the current from a secondary value up to the primary side of an instrument transformer.

Cumulative Demand:

The sum of the previous billing period maximum demand readings at the time of billing period reset. The maximum demand for the most recent billing period is added to the previously accumulated total of the maximum demands.

Demand:

The average value of power or a similar quantity over a specified period of time.

Demand Interval:

A specified time over which demand is calculated.

Display:

User-configurable visual indication of data in a meter.

DNP 3.0:

A robust, non-proprietary protocol based on existing open standards. DNP 3.0 is used to operate between various systems in electric and other utility industries and SCADA networks.

More information is available in the *EPM 9000 Series DNP Guide*.

EEPROM:

Nonvolatile memory; Electrically Erasable Programmable Read Only Memory that retains its data during a power outage without need for a battery. Also refers to meter's FLASH memory.

Energy Register:

Programmable record that monitors any energy quantity. Example: Watt-hours, VAR-hours, VA-hours.

Ethernet:

A type of LAN network connection that connects two or more devices on a common communications backbone. An Ethernet LAN consists of at least one hub device (the network backbone) with multiple devices connected to it in a star configuration. The most common versions of Ethernet in use are 10BaseT and 100BaseT as defined in IEEE 802.3 standards. However, several other versions of Ethernet are also available.

Flicker:

Flicker is the sensation that is experienced by the human visual system when it is subjected to changes occurring in the illumination intensity of light sources. IEC 61000-4-15 and former IEC 868 describe the methods used to determine Flicker severity.

Harmonics:

Measuring values of the fundamental current and voltage and percent of the fundamental.

I²T Threshold:

Data will not accumulate until current reaches programmed level.

Integer:

Any of the natural numbers, the negatives of those numbers, or zero.

Invalid Register:

In the EPM 9900P meter's Modbus Map there are gaps between Registers. For example, the next Register after 08320 is 34817. Any unmapped Register stores no information and is said to be invalid.

ITIC Curve:

An updated version of the CBEMA Curve that reflects further study into the performance of microprocessor devices. The curve consists of a series of steps but still defines combinations of voltage magnitude and duration that will cause malfunction or damage.

Ke:

kWh per pulse; i.e. the energy.

kWh:

Kilowatt hours; kW x demand interval in hours.

KYZ Output:

Output where the rate of changes between 1 and 0 reflects the magnitude of a metered quantity.

LCD:

Liquid Crystal Display.

LED:

Light Emitting Diode.

Maximum Demand:

The largest demand calculated during any interval over a billing period.

Modbus ASCII:

Alternate version of the Modbus protocol that utilizes a different data transfer format. This version is not dependent upon strict timing, as is the RTU version. This is the best choice for telecommunications applications (via modems).

More information is available in the *EPM 9900P Modbus Guide*.

Modbus RTU:

The most common form of Modbus protocol. Modbus RTU is an open protocol spoken by many field devices to enable devices from multiple vendors to communicate in a common language. Data is transmitted in a timed binary format, providing increased throughput and therefore, increased performance.

More information is available in the *EPM 9900P Modbus Guide*.

Network:

A communications connection between two or more devices to enable those devices to send to and receive data from one another. In most applications, the network is either a serial type or a LAN type.

NVRAM:

Nonvolatile Random Access Memory: able to keep the stored values in memory even during the loss of circuit or control power. High speed NVRAM is used in the EPM 9900P meter to gather measured information and to insure that no information is lost.

Optical Port:

A port that facilitates infrared communication with a meter. Using an ANSI C12.13 Type II magnetic optical communications coupler and an RS232 cable from the coupler to a PC, the meter can be programmed with GE Communicator software.

Packet:

A short fixed-length section of data that is transmitted as a unit. Example: a serial string of 8-bit bytes.

Percent (%) THD:

Percent Total Harmonic Distortion. (See THD.)

Protocol:

A language that is spoken between two or more devices connected on a network.

PT Ratio:

Potential Transformer Ratio used to scale the value of the voltage to the primary side of an instrument transformer. Also referred to as VT Ratio.

Pulse:

The closing and opening of the circuit of a two-wire pulse system or the alternate closing and opening of one side and then the other of a three-wire system (which is equal to two pulses).

Q Readings:

Q is the quantity obtained by lagging the applied voltage to a wattmeter by 60 degrees. Values are displayed on the Uncompensated Power and Q Readings screen.

Quadrant (Programmable Values and Factors on the EPM 9900P meter):

Watt and VAR flow is typically represented using an X-Y coordinate system. The four corners of the X-Y plane are referred to as quadrants. Most power applications label the right hand corner as the first quadrant and number the remaining quadrants in a counter-clockwise rotation. Following are the positions of the quadrants: 1st - upper right, 2nd - upper left, 3rd - lower left and 4th - lower right.

Power flow is generally positive in quadrants 1 and 4.

VAR flow is positive in quadrants 1 and 2. The most common load conditions are: Quadrant 1 - power flow positive, VAR flow positive, inductive load, lagging or positive power factor; Quadrant 2 - power flow negative, VAR flow positive, capacitive load, leading or negative power factor.

Register:

An entry or record that stores a small amount of data.

Register Rollover:

A point at which a Register reaches its maximum value and rolls over to zero.

Reset:

Logs are cleared or new (or default) values are sent to counters or timers.

Rolling Window Average (Power):

The Rolling (Sliding) Window Average is the average power calculated over a user-set time interval that is derived from a specified number of sub-intervals, each of a specified time. For example, the average is calculated over a 15-minute interval by calculating the sum of the average of three consecutive 5-minute intervals. This demand calculation methodology has been adopted by several utilities to prevent customer manipulation of kW demand by simply spreading peak demand across two intervals.

RS232:

A type of serial network connection that connects two devices to enable communication between the devices. An RS232 connection connects only two points. Distance between devices is typically limited to fairly short runs.

Current standards recommend a maximum of 50 feet but some users have had success with runs up to 100 feet. Communications speed is typically in the range of 1200 bits per second to 57,600 bits per second. RS232 connection can be accomplished using Port 1 of the EPM 9900P meter.

RS485:

A type of serial network connection that connects two or more devices to enable communication between the devices. An RS485 connection allows multi-drop communication from one to many points.

Distance between devices is typically limited to around 2,000 to 3,000 wire feet. Communications speed is typically in the range of 120 bits per second to 115,000 bits per second.

Sag:

A voltage quality event during which the RMS voltage is lower than normal for a period of time, typically from 1/2 cycle to 1 minute.

Secondary Rated:

Any Register or pulse output that does not use any CT or PT(VT) Ratio.

Serial Port:

The type of port used to directly interface with a device using the RS232 standard.

Swell:

A voltage quality event during which the RMS voltage is higher than normal for a period of time, typically from 1/2 cycle to 1 minute.

TDD:

The Total Demand Distortion of the current waveform. The ratio of the root-sum-square value of the harmonic current to the maximum demand load current. (See equation below.)

NOTE: The TDD displayed in the Harmonics screen is calculated by GE Communicator software, using the Max Average Demand.

$$TDD_I = \frac{\sqrt{I_2^2 + I_3^2 + I_4^2 + I_5^2 + \dots}}{I_L} \times 100\%$$

THD:

Total Harmonic Distortion is the combined effect of all harmonics measured in a voltage or current. The THD number is expressed as a percent of the fundamental. For example, a 3% THD indicates that the magnitude of all harmonic distortion measured equals 3% of the magnitude of the fundamental 60Hz quantity. The %THD displayed is calculated by your EPM 9900P meter.

Time Stamp:

A stored representation of the time of an event. Time Stamp can include year, month, day, hour, minute, second and Daylight Savings Time indication.

TOU:

Time of Use.

Uncompensated Power:

VA, Watt and VAR readings not adjusted by Transformer Loss Compensation.

V2T Threshold:

Data stops accumulating when voltage falls below programmed level.

Voltage Imbalance:

The ratio of the voltage on a phase to the average voltage on all phases.

Voltage Quality Event:

An instance of abnormal voltage on a phase. The events the meter tracks include sags, swells, interruptions and imbalances.

VT Ratio:

The Voltage Transformer Ratio is used to scale the value of the voltage to the primary side of an instrument transformer. Also referred to as PT Ratio.

Voltage, Vab:

Vab, Vbc, Vca are all Phase-to-Phase voltage measurements. These voltages are measured between the three phase voltage inputs to the meter.

Voltage, Van:

Van, Vbn, Vcn are all Phase-to-Neutral voltages applied to the monitor. These voltages are measured between the phase voltage inputs and Vn input to the meter. Technologically, these voltages can be "measured" even when the meter is in a Delta configuration and there is no connection to the Vn input. However, in this configuration, these voltages have limited meaning and are typically not reported.

Voltage, Vaux:

This is the fourth voltage input measured from between the Vaux and Vref inputs. This input can be scaled to any value. However, the actual input voltage to the meter should be of the same magnitude as the voltages applied to the Va, Vb and Vc terminals.