



GE VERNOVA

## PQM II Power Quality Meter



### Instruction Manual

Software Revision: 2.35

Manual P/N: 1601-0118-AI

Manual Order Code: GEK-106435S



© 2026 GE Vernova. All rights reserved.

GE Vernova PQM II Power Quality Meter instruction manual for revision 2.35.

PQM II Power Quality Meter, is a registered trademark of GE Vernova.

The contents of this manual are the property of GE Vernova. This documentation is furnished on license and may not be reproduced in whole or in part without the permission of GE Vernova. This manual is for informational use only and is subject to change without notice.

Part numbers contained in this manual are subject to change without notice, and should therefore be verified by GE Vernova before ordering.

Part number: 1601-0118-AI (June 2026)

## For further assistance

For product support, contact the information and call center as follows:

GE Vernova  
650 Markland Street  
Markham, Ontario  
Canada L6C 0M1

Worldwide telephone: +1 905 927 7070

North America toll-free: 1 800 547 8629

Fax: +1 905 927 5098

Worldwide e-mail: [multilin.tech@gevernova.com](mailto:multilin.tech@gevernova.com)

Website: [www.gevernova.com/grid-solutions](http://www.gevernova.com/grid-solutions)

# Table of Contents

---

1: OVERVIEW	INTRODUCTION TO THE PQM II .....	1-1
	DESCRIPTION .....	1-1
	FEATURE HIGHLIGHTS .....	1-2
	APPLICATIONS OF THE PQM II .....	1-2
	STANDARD FEATURES .....	1-5
	METERING .....	1-5
	ALARMS .....	1-5
	COMMUNICATIONS .....	1-5
	FUTURE EXPANSION .....	1-5
	OPTIONAL FEATURES .....	1-6
	.....	1-6
	TRANSDUCER INPUT/OUTPUTS (ORDER CODE OPTION T20 OR T1) ..	1-6
	CONTROL OPTION (ORDER CODE OPTION C) .....	1-6
	POWER ANALYSIS OPTION (ORDER CODE OPTION A) .....	1-7
	ENERVISTA PQM II SETUP SOFTWARE .....	1-11
	OVERVIEW .....	1-11
	ORDER CODES .....	1-12
	ORDER CODE TABLE .....	1-12
	MODIFICATIONS .....	1-13
	ACCESSORIES .....	1-13
	CONTROL POWER .....	1-13
	SPECIFICATIONS .....	1-13
	INPUTS/OUTPUTS .....	1-13
	TRACE MEMORY TRIGGER .....	1-14
	SAMPLING MODES .....	1-15
	OUTPUT RELAYS .....	1-15
	METERING .....	1-15
	MONITORING .....	1-16
	SYSTEM .....	1-17
	TESTING AND APPROVALS .....	1-18
	PHYSICAL .....	1-19

---

2:	PHYSICAL CONFIGURATION .....	2-1
INSTALLATIONPHYSI	PRODUCT IDENTIFICATION .....	2-2
CAL CONFIGURATION	MANUAL AND FIRMWARE REVISIONS .....	2-2
	ELECTRICAL CONFIGURATION .....	2-3
	EXTERNAL CONNECTIONS .....	2-3
	WIRING DIAGRAMS .....	2-5
	3-WIRE SYSTEM USING TWO CTs .....	2-12
	CONTROL POWER .....	2-13
	VT INPUTS .....	2-13
	CT INPUTS .....	2-13
	OUTPUT RELAYS .....	2-14
	SWITCH INPUTS (OPTIONAL) .....	2-14
	ANALOG OUTPUTS (OPTIONAL) .....	2-16
	ANALOG INPUT (OPTIONAL) .....	2-17
	RS485 SERIAL PORTS .....	2-17
	RS232 FRONT PANEL PORT .....	2-19
	DIELECTRIC STRENGTH TESTING .....	2-20

---

3: OPERATION	FRONT PANEL AND DISPLAY .....	3-1
	FRONT PANEL .....	3-1
	DISPLAY .....	3-1
	LED INDICATORS .....	3-2
	DESCRIPTION .....	3-2
	STATUS .....	3-2
	COMMUNICATE .....	3-2
	RELAYS .....	3-3
	KEYPAD .....	3-3
	DESCRIPTION .....	3-3
	MENU KEY .....	3-3
	ESCAPE KEY .....	3-3
	ENTER KEY .....	3-4
	RESET KEY .....	3-4
	MESSAGE KEYS .....	3-5
	VALUE KEYS .....	3-5
	DATA ENTRY METHODS .....	3-6
	SETPOINT ACCESS SECURITY .....	3-6
	DEFAULT MESSAGES .....	3-7
	DESCRIPTION .....	3-7
	ADDING A DEFAULT MESSAGE .....	3-7
	DELETING A DEFAULT MESSAGE .....	3-7
	DEFAULT MESSAGE SEQUENCE .....	3-8

---

4: SOFTWARE	INTRODUCTION .....	4-1
	OVERVIEW .....	4-1
	HARDWARE .....	4-1
	INSTALLING THE ENERVISTA PQM II SETUP SOFTWARE .....	4-3
	CONFIGURING SERIAL COMMUNICATIONS .....	4-4
	DESCRIPTION .....	4-4
	UPGRADING FIRMWARE .....	4-5
	DESCRIPTION .....	4-5
	SAVING SETPOINTS TO A FILE .....	4-5
	LOADING NEW FIRMWARE .....	4-5
	CONVERTING PQM SETTING FILES BELOW V3.60 FOR IMPORT INTO THE PQM II V2.35 SETUP SOFTWARE .....	4-7
	LOADING SAVED SETPOINTS .....	4-9
	USING THE ENERVISTA PQM II SETUP SOFTWARE .....	4-10
	ENTERING SETPOINTS .....	4-10
	VIEWING ACTUAL VALUES .....	4-11
	SETPOINT FILES .....	4-11
	GETTING HELP .....	4-11
	POWER ANALYSIS .....	4-11
	WAVEFORM CAPTURE .....	4-11
	HARMONIC ANALYSIS .....	4-12
	TRACE MEMORY .....	4-13
	DATA LOGGER .....	4-15
	VOLTAGE DISTURBANCE RECORDER (VDR) .....	4-17
	USING ENERVISTA VIEWPOINT MONITOR WITH THE PQM II .....	4-19
	PLUG AND PLAY EXAMPLE .....	4-19

---

5: SETPOINTS	INTRODUCTION ..... 5-1	5-1
	SETPOINT ENTRY METHODS ..... 5-1	5-1
	SETPOINTS MAIN MENU ..... 5-2	5-2
	S1 PQM II SETUP ..... 5-4	5-4
	DESCRIPTION ..... 5-4	5-4
	PREFERENCES ..... 5-5	5-5
	SETPOINT ACCESS ..... 5-5	5-5
	SERIAL PORTS ..... 5-7	5-7
	DNP 3.0 CONFIGURATION ..... 5-8	5-8
	CLOCK ..... 5-8	5-8
	CALCULATION PARAMETERS ..... 5-10	5-10
	CLEAR DATA ..... 5-12	5-12
	EVENT RECORDER ..... 5-13	5-13
	TRACE MEMORY ..... 5-14	5-14
	PROGRAMMABLE MESSAGE ..... 5-17	5-17
	PRODUCT OPTIONS ..... 5-18	5-18
	S2 SYSTEM SETUP ..... 5-18	5-18
	CURRENT AND VOLTAGE CONFIGURATION ..... 5-18	5-18
	ANALOG OUTPUTS ..... 5-21	5-21
	ANALOG INPUT ..... 5-25	5-25
	SWITCH INPUTS ..... 5-27	5-27
	PULSE OUTPUT ..... 5-28	5-28
	PULSE INPUT ..... 5-29	5-29
	DATA LOGGER ..... 5-30	5-30
	VOLTAGE DISTURBANCE ..... 5-30	5-30
	S3 OUTPUT RELAYS ..... 5-31	5-31
	DESCRIPTION ..... 5-31	5-31
	ALARM RELAY ..... 5-31	5-31
	AUXILIARY RELAYS ..... 5-31	5-31
	S4 ALARMS/CONTROL ..... 5-32	5-32
	CURRENT/VOLTAGE ALARMS ..... 5-32	5-32
	HARMONIC DISTORTION ..... 5-37	5-37
	FREQUENCY ..... 5-38	5-38
	POWER ALARMS ..... 5-39	5-39
	POWER FACTOR ..... 5-41	5-41
	DEMAND ALARMS ..... 5-44	5-44
	PULSE INPUT ..... 5-46	5-46
	TIME ..... 5-47	5-47
	MISCELLANEOUS ALARMS ..... 5-48	5-48
	S5 TESTING ..... 5-49	5-49
	TEST RELAYS AND LEDs ..... 5-49	5-49
	CURRENT/VOLTAGE ..... 5-49	5-49
	ANALOG OUTPUTS ..... 5-50	5-50
	ANALOG INPUT ..... 5-51	5-51
	SWITCH INPUTS ..... 5-51	5-51
	FACTORY USE ONLY ..... 5-52	5-52

---

6: MONITORING	VIEWING ACTUAL VALUES ..... 6-1	6-1
	DESCRIPTION ..... 6-1	6-1
	ACTUAL VALUES MENU ..... 6-2	6-2
	A1 METERING ..... 6-3	6-3
	CURRENT METERING ..... 6-3	6-3

VOLTAGE METERING .....	6-5
PHASORS .....	6-7
POWER METERING .....	6-7
ENERGY METERING .....	6-11
DEMAND METERING .....	6-13
FREQUENCY METERING .....	6-14
PULSE INPUT COUNTERS .....	6-15
ANALOG INPUT .....	6-16
<b>A2 STATUS .....</b>	<b>6-17</b>
ALARMS .....	6-17
SWITCH STATUS .....	6-19
CLOCK .....	6-20
PROGRAMMABLE MESSAGE .....	6-20
<b>A3 POWER ANALYSIS .....</b>	<b>6-20</b>
POWER QUALITY .....	6-20
THD .....	6-21
DATA LOGGER .....	6-22
EVENT RECORDER .....	6-23
VOLTAGE DISTURBANCE .....	6-27
<b>A4 PRODUCT INFO .....</b>	<b>6-28</b>
SOFTWARE VERSIONS .....	6-28
MODEL INFORMATION .....	6-28

---

## 7: APPLICATIONS

<b>EVENT RECORDER .....</b>	<b>7-1</b>
LIST OF EVENTS .....	7-1
ACCESS TO EVENT RECORDER INFORMATION .....	7-6
<b>INTERFACING USING HYPERTERMINAL .....</b>	<b>7-7</b>
UPGRADING FIRMWARE .....	7-7
CYCLING POWER .....	7-8
HYPERTERMINAL .....	7-8
<b>PHASOR IMPLEMENTATION .....</b>	<b>7-10</b>
THEORY OF PHASOR IMPLEMENTATION .....	7-10
<b>TRIGGERED TRACE MEMORY .....</b>	<b>7-12</b>
DESCRIPTION .....	7-12
<b>PULSE OUTPUT .....</b>	<b>7-12</b>
PULSE OUTPUT CONSIDERATIONS .....	7-12
CONNECTING TO AN END RECEIVER USING KYZ TERMINALS .....	7-13
<b>DATA LOGGER IMPLEMENTATION .....</b>	<b>7-13</b>
DATA LOGGER STRUCTURE .....	7-13
MODES OF OPERATION .....	7-15
ACCESSING DATA LOG INFORMATION .....	7-15
INTERPRETING DATA LOG INFORMATION .....	7-15
DATA LOG PARAMETERS .....	7-18
<b>READING LONG INTEGERS FROM THE MEMORY MAP .....</b>	<b>7-19</b>
DESCRIPTION .....	7-19
EXAMPLE .....	7-19
<b>PULSE INPUT APPLICATION .....</b>	<b>7-20</b>
DESCRIPTION .....	7-20
PQM II PULSE INPUT(S) WITH A PULSE INITIATOR USING KYZ TERMINALS	7-20
<b>PULSE TOTALIZER APPLICATION .....</b>	<b>7-21</b>
DESCRIPTION .....	7-21
TOTALIZING ENERGY FROM MULTIPLE METERING LOCATIONS .....	7-22

---

8: WARRANTY	GE VERNOVA WARRANTY .....	8-1
	WARRANTY STATEMENT .....	8-1

---

A: APPENDIX A	MOD 506: CAPACITOR BANK SWITCHING .....	A-1
	DESCRIPTION .....	A-1
	SETPOINTS .....	A-1
	ACTUAL VALUES .....	A-3
	CONDITIONS REQUIRED TO ENERGIZE A STEP .....	A-4
	ADDITIONS TO MODBUS MEMORY MAP .....	A-5
	REVISION HISTORY .....	A-6
	RELEASE DATES .....	A-6
	RELEASE NOTES .....	A-7

---

B: INDEX



# PQM II Power Quality Meter

## Chapter 1: Overview

---

### Introduction to the PQM II

#### Description

The GE Vernova Multilin PQM II Power Quality Meter is an ideal choice for continuous monitoring of a single or three-phase systems in large scale fixed installations such as control and switchgear for electrical utility and substations and other industrial applications. It provides metering for current, voltage, real power, reactive power, apparent power, energy use, cost of power, power factor, and frequency.

Programmable setpoints and four assignable output relays allow control functions to be added for specific applications. This includes basic alarm on over/under current or voltage, unbalance, demand-based load shedding, and capacitor power factor correction control. More complex control is possible using the four switch inputs; these can also be used for status information such as breaker open/closed and flow information.

As a data gathering device for plant automation systems that integrate process, instrument, and electrical requirements, all monitored values are available via one of two RS485 communication ports running the Modbus protocol. If analog values are required for direct interface to a PLC, any of the monitored values can output as a 4 to 20 mA (or 0 to 1 mA) signal to replace up to four (4) separate transducers. A third RS232 communication port connects to a PC from the front panel for simultaneous access of information by other plant personnel.

With increasing use of electronic loads such as computers, ballasts, and variable frequency drives, the quality of the power system is important. With the harmonic analysis option, any phase current or voltage can be displayed and the harmonic content calculated. Knowledge of the harmonic distribution allows action to be taken to prevent overheated transformers, motors, capacitors, neutral wires, and nuisance breaker trips. Redistribution of system loading can also be determined. The PQM II can also provide waveform and data printouts to assist in problem diagnosis.

## Feature Highlights

- Monitoring: A, V, VA, W, var, kWh, kvarh, kVAh, PF, Hz
- Demand metering: W, var, A, VA
- Setpoints for alarm or control from most measured values, including: unbalance, frequency, power factor, voltage, and current
- four (4) output relays / four (4) switch inputs for flexible control configuration
- four (4) isolated analog outputs replace transducers for PLC interface
- one 4 to 20 mA analog input
- Modbus communications
- Three COM ports (two rear RS485 ports and one front RS232 port) for access by process, electrical, maintenance, and instrument personnel
- Harmonic analysis for power quality review and problem correction
- 40-character display and keypad for local programming
- No-charge EnerVista PQM II Setup Software
- Simulation mode for testing and training
- Compact design for panel mount
- AC/DC control power

## Applications of the PQM II

- Metering of distribution feeders, transformers, generators, capacitor banks, and motors
- Medium and low voltage three-phase systems
- Commercial, industrial, utility, large scale fixed installations
- Flexible control for demand load shedding, power factor, etc.
- Power quality analysis
- System debugging

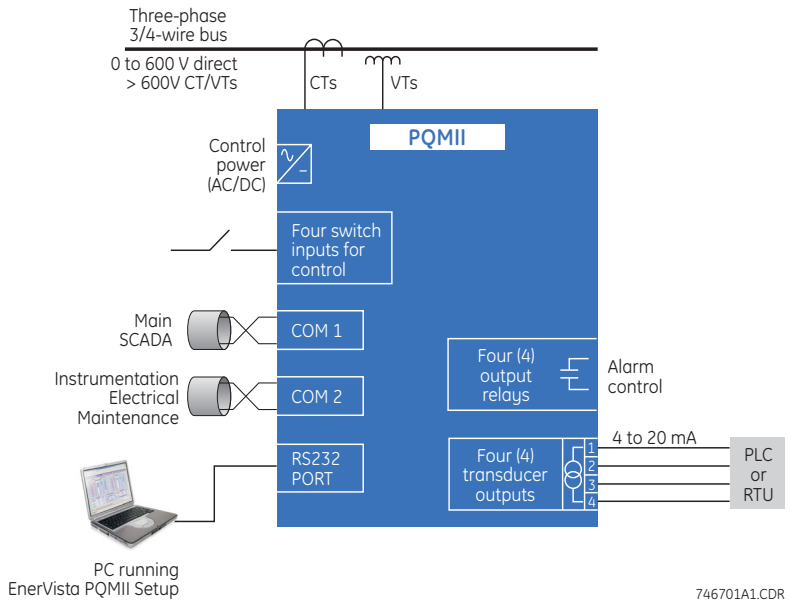

FIGURE 1-1: Single Line Diagram

746701A1.CDR

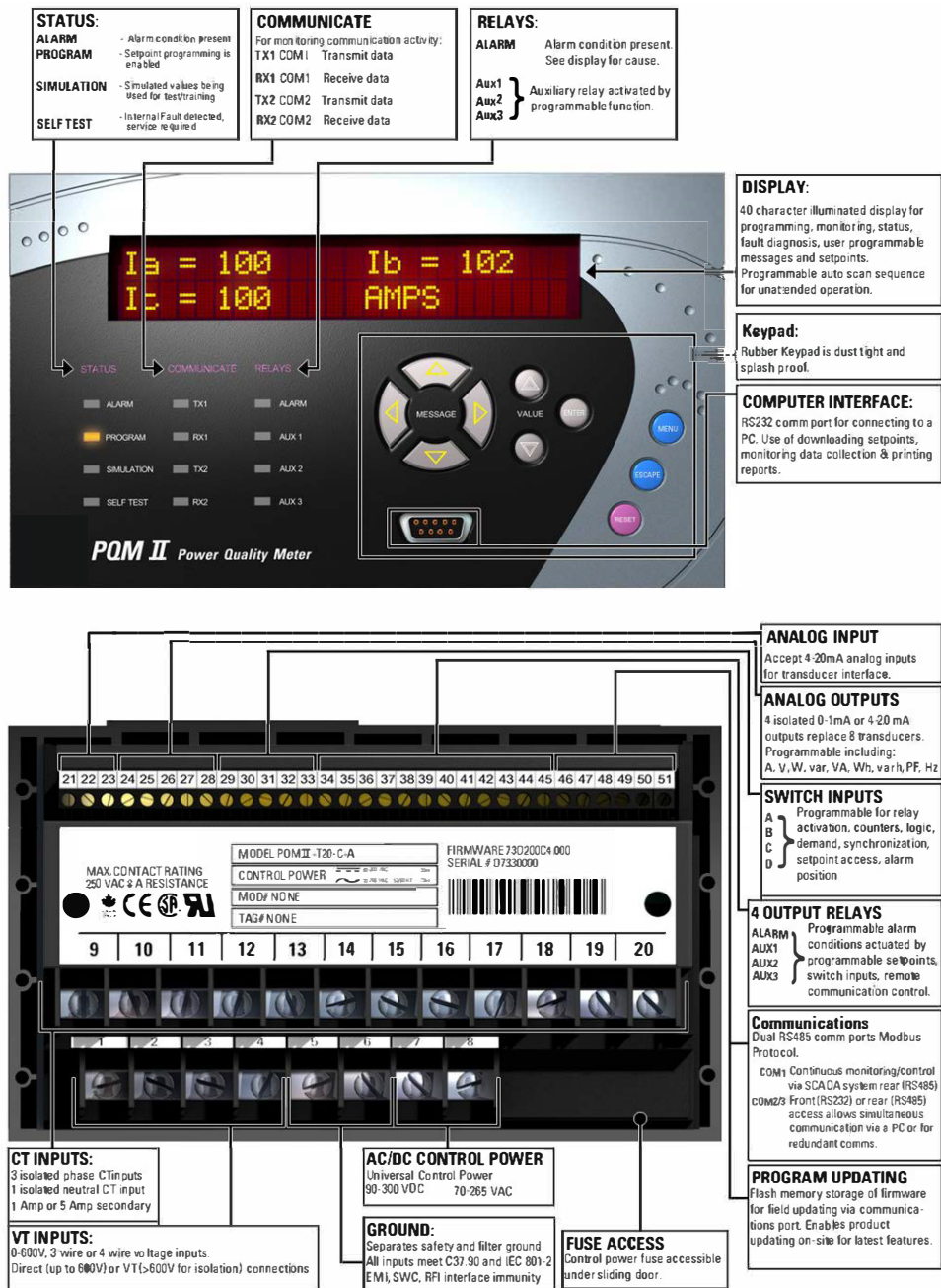

FIGURE 1-2: Feature Highlights

---

## Standard Features

### Metering

True RMS monitoring of Ia, Ib, Ic, In, Van, Vbn, Vcn, Vab, Vbc, Vca, voltage/current unbalance, power factor, line frequency, watts, vars, VA, Wh, varh, VAh, and demand readings for A, W, vars, and VA. Maximum and minimum values of measured quantities are recorded and are date and time stamped.

A 40-character liquid crystal display is used for programming setpoints and monitoring values and status.

### Alarms

Alarm conditions can be set up for all measured quantities. These include overcurrent, undercurrent, neutral current, current unbalance, voltage unbalance, phase reversal, overfrequency, underfrequency, power factor, switch inputs, etc. The alarm messages are displayed in a simple and easy to understand English format.

### Communications

The PQM II is equipped with one standard RS485 port utilizing the Modbus or DNP protocols. This can be used to integrate process, instrumentation, and electrical requirements in a plant automation system by connecting several PQM II meters together to a DCS or SCADA system. A PC running the EnerVista PQM II Setup Software can change system setpoints and monitor values, status, and alarms. Continuous monitoring minimizes process downtime by immediately identifying potential problems due to faults or changes from growth.

The PQM II also includes a front RS232 port which can be used for the following tasks:

- data monitoring
- problem diagnosis
- viewing event records
- trending
- printing settings and/or actual values
- loading new firmware into the PQM II

### Future Expansion

The PQM II is capable of upgrades to both its firmware as well as to add enhanced functionality post purchase. Firmware updates, enhancing functionality (through purchasing upgrades) are upgraded via the serial port and EnerVista PQM II Setup software.

## Optional Features

The following optional features are available to add to a base PQM II meter (Order Code PQMII)

### Transducer Input/Outputs (Order Code Option T20 or T1)

This optional order code option provides:

- Four isolated 4 to 20 mA (T20) or 0 to 1 mA (T1) analog outputs are provided that can replace up to eight transducers. The outputs can be assigned to any measured parameters for direct interface to a PLC.
- One 4 to 20 mA analog input is provided to accept a transducer output for displaying information such as temperature or water level.
- An additional rear RS485 communication port is provided for simultaneous monitoring by process, instrument, electrical, or maintenance personnel.

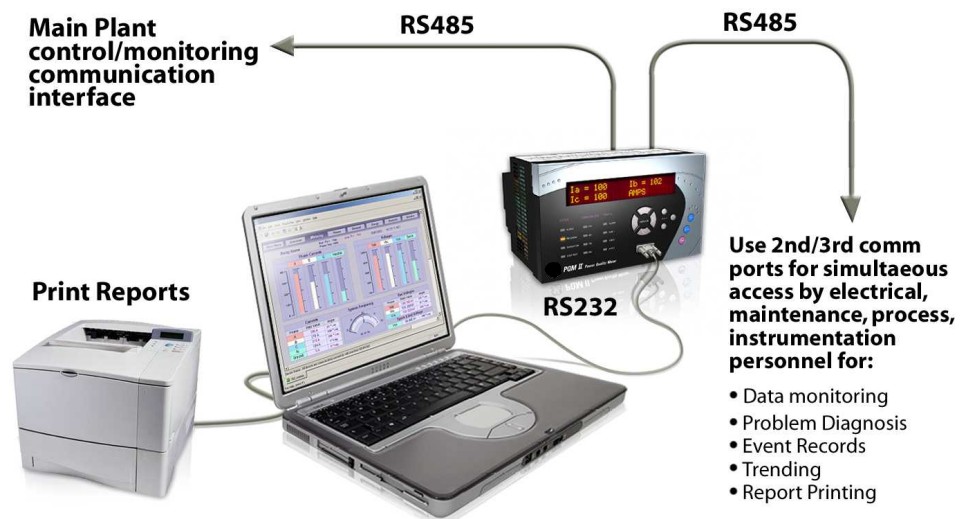

FIGURE 1-3: Additional Communication Port

### Control Option (Order Code Option C)

With the Control order code option C an additional three dry-contact form “C” output relays and four dry-contact switch inputs are provided. These additional relays can be combined with setpoints and inputs/outputs for a variety of control applications including:

- monitoring uptime via alarms for system awareness and reliability
- undercurrent alarm warnings for pump protection
- overvoltage/undervoltage for generators

- unbalance alarm warnings to protect rotating machines
- dual level power factor for capacitor bank switching
- underfrequency/demand output for load shedding helping with power cost savings
- kWh, kvarh and kVAh pulse output for PLC interface
- Pulse input for totalizing quantities such as kWh, kvarh, kVAh, etc for energy management applications.

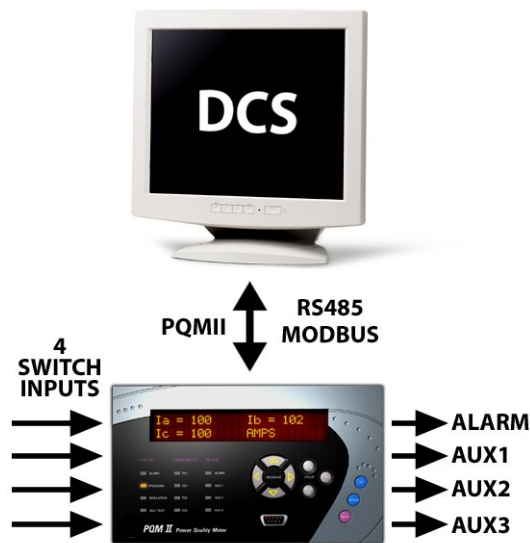

FIGURE 1-4: Switch Inputs and Outputs Relays

## Power Analysis Option (Order Code Option A)

The Power Analysis Option provides a variety of power quality functionality including waveform and harmonic analysis.

This is especially useful when the system includes monitoring of non-linear loads (such as variable speed drives, computers, and electronic ballasts) which can cause unwanted harmonics that may lead to nuisance breaker tripping; electronic interference; and transformer, capacitor or motor overheating greatly impacting the reliability of a system and processes.

Over and above the monitoring data, this option also assists with fault diagnostics such as detecting undersized neutral wiring; system planning/assessing the need for harmonic rated transformers; evaluating the need or effectiveness of harmonic filters for return on investment; and analyzing the details of the harmonic spectrum to proactively mitigate predicted future issues.

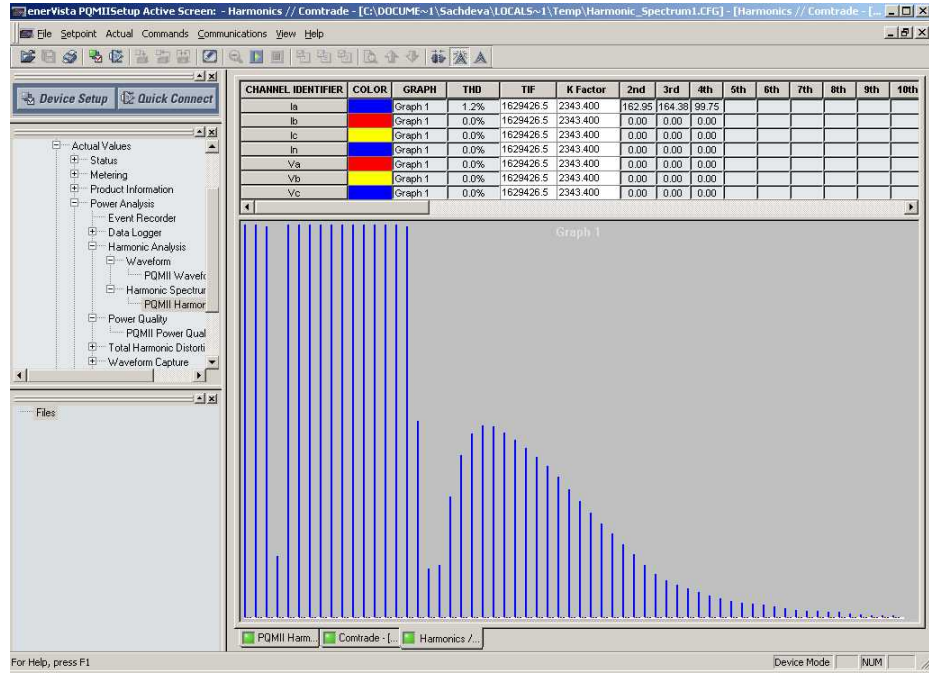

FIGURE 1–5: Harmonic Spectrum

Voltage and current waveforms can be captured on the PQM II and then visualized on a workstation using PQM II setup.

Furthermore GE Vernona's HMI software solution EnerVista Viewpoint Monitoring can automatically collect (from relays and meters), centralize and visualize this power quality and other device data in a centralized HMI system solution.

As an example, the makes visualizing power quality data (e.g. distorted peaks or notches from events such as switching activities) or other disturbances in the system to allow operators to monitor as well as take corrective action.

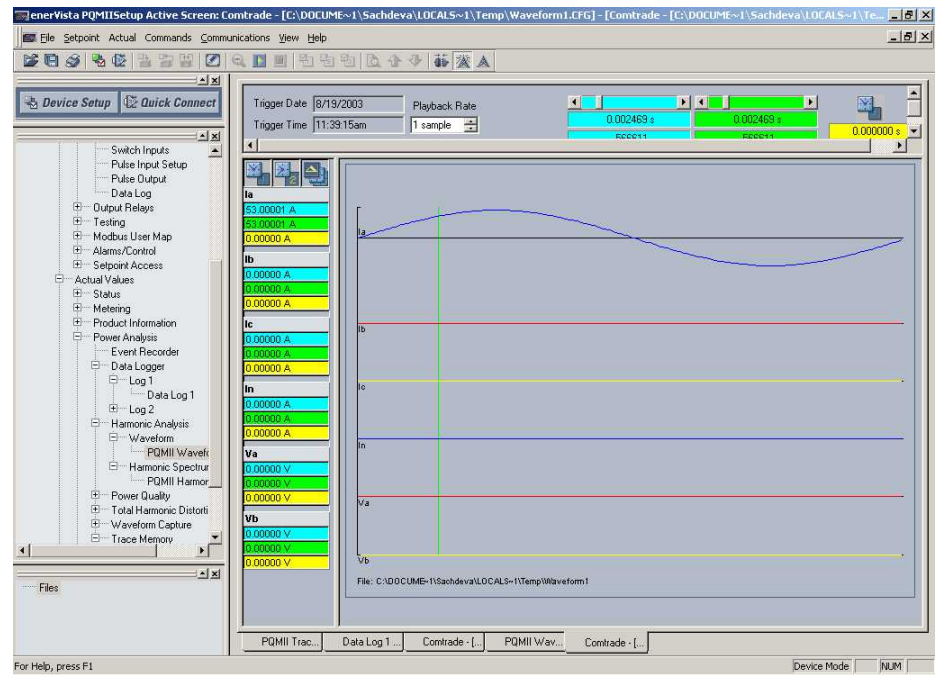

FIGURE 1-6: Captured Waveform

Alarms, triggers, and input/output events can be stored in a 150-event record and time/date stamped by the internal clock. This is useful for diagnosing problems and system activity. The event record is available through serial communication. Minimum and maximum values are also continuously updated and time/date stamped.

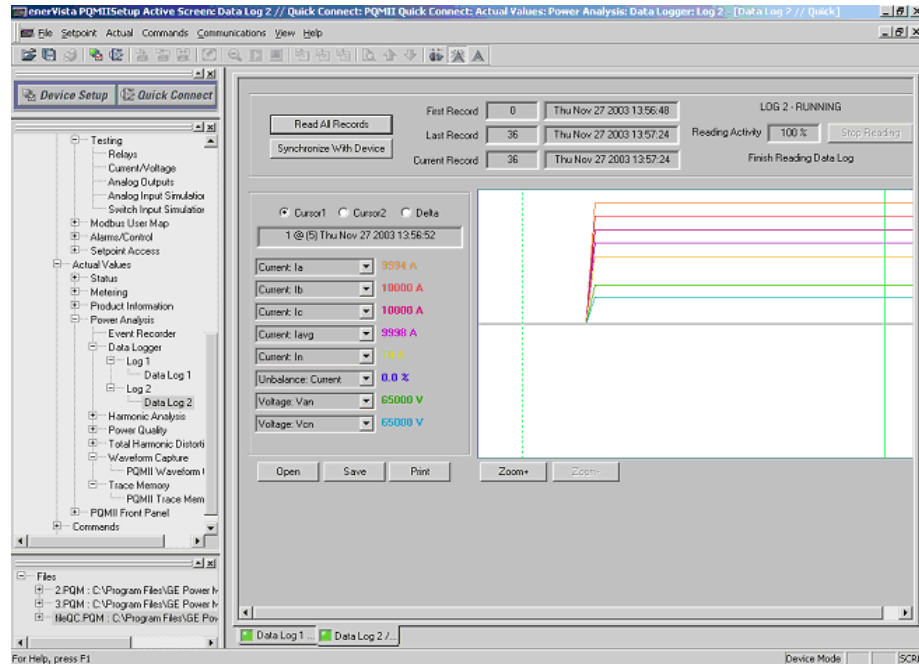

FIGURE 1-7: Data Logger

Routine event logs of all measured quantities can be created, saved to a file, and/or printed.

For additional information on waveform sampling and analysis features, see *Power Analysis* on page 4-11.

The power analysis option also provides a Trace Memory feature. This feature can be used to record specified parameters based on the user defined triggers.

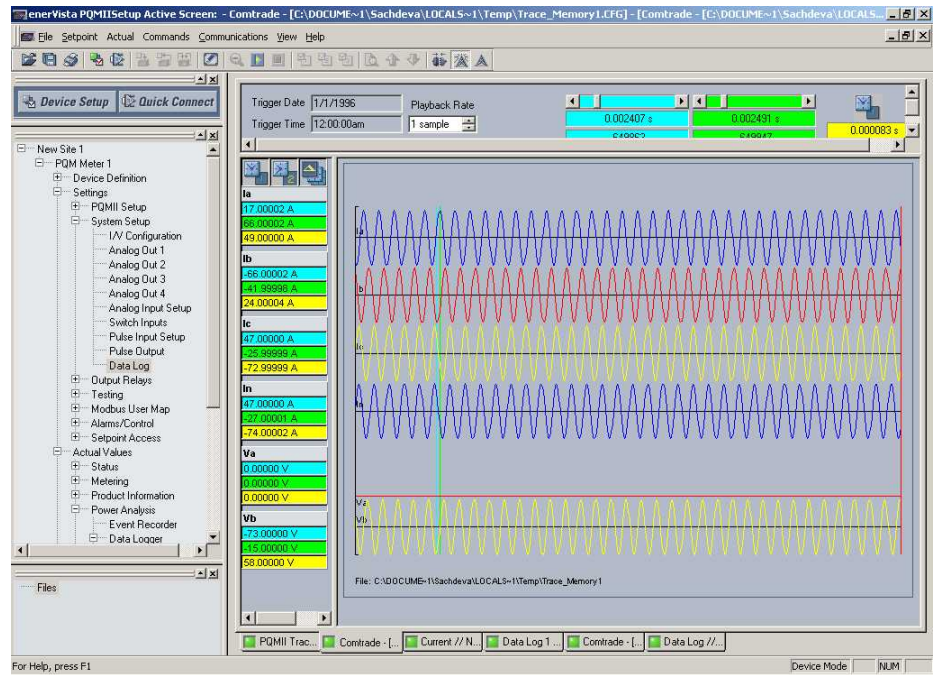

FIGURE 1–8: Trace Memory Capture

## EnerVista PQM II Setup Software

### Overview

All data continuously gathered by the PQM II can be transferred to a third party software program for display, control, or analysis through the communications interface. The EnerVista PQM II Setup Software allows the user to view and manipulate this data and assists in programming the PQM II. Some of the tasks that can be executed using the EnerVista PQM II Setup Software package include:

- reading metered data
- monitoring system status
- changing PQM II setpoints on-line
- saving setpoints to a file and downloading into any PQM II
- capturing and displaying voltage and current waveforms for analysis
- recording demand profiles for various measured quantities
- troubleshooting communication problems with a built in debugger
- printing graphs, charts, setpoints, and actual values

The EnerVista PQM II Setup Software is fully described in *Software* on page 4–1.

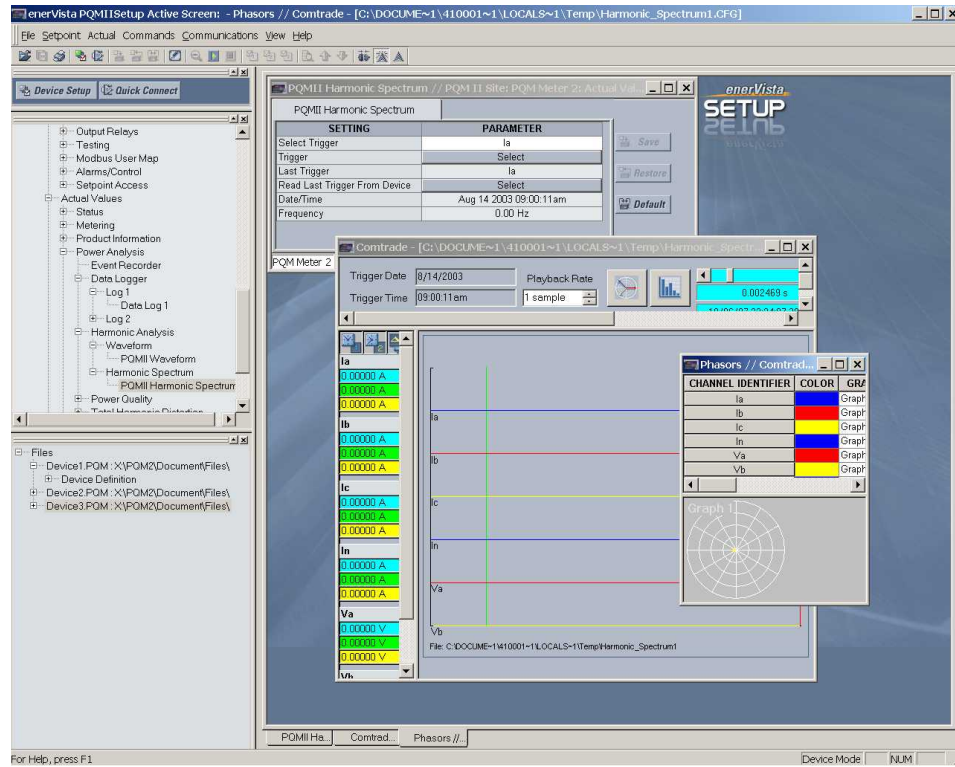

FIGURE 1-9: EnerVista PQM II Setup Software Main Window

## Order Codes

### Order Code Table

The order code for all options is: **PQM II-T20-C-A**

Table 1: Order Codes

	PQM II	*	*	*	
Basic Unit	PQM II	-	-	-	Basic unit with display, all current/voltage/power measurements, one (1) RS485 communication port, one (1) RS232 communication port
Transducer Option		T20	-	-	Four (4) isolated analog outputs, 0-20 mA and 4-20 mA assignable to all measured parameters, 4-20 mA analog input, 2nd RS485 communication port
		T1	-	-	Four (4) isolated analog outputs, 0-1 mA assignable to all measured parameters, 4-20 mA analog input, 2nd RS485 communication port
Control Option			C	-	Three (3) additional programmable output relays (for a total of 4), 4 programmable switch inputs
Power Analysis Option				A	Harmonic analysis, triggered trace memory, waveform capture, event recorder, data logger, voltage disturbance recorder*

\* The voltage disturbance recorder is only available with the 25 MHz processor.



VT Ratio: ..... 1:1 to 3500:1  
 Burden: ..... 2.2 M $\Omega$   
 Input Range: ..... 40 to 600 V AC  
 Full scale:  
   for VT input  $\leq$ 150 V AC: ..... 150 V AC  
   for VT input  $>$ 150 V AC: ..... 600 V AC  
 Frequency: ..... up to 32nd harmonic  
 Accuracy: .....  $\pm$ 0.2% of full scale

**SWITCH INPUTS**

Type: ..... dry contacts  
 Resistance: ..... 1000  $\Omega$  max ON resistance  
 Output: ..... 24 V DC at 2 mA (pulsed)  
 Duration: ..... 100 ms minimum

**ANALOG OUTPUT (0–1 MA)**

Max. load: ..... 2400  $\Omega$   
 Max. output: ..... 1.1 mA  
 Accuracy: .....  $\pm$ 1% of full-scale reading  
 Isolation: .....  $\pm$ 36 V DC isolated, active source

**ANALOG OUTPUT (4–20 MA)**

Max. load: ..... 600  $\Omega$   
 Max. output: ..... 21 mA  
 Accuracy: .....  $\pm$ 1% of full-scale reading  
 Isolation: .....  $\pm$ 36 V DC isolated, active source

**ANALOG INPUT**

Range: ..... 4 to 20 mA  
 Accuracy: .....  $\pm$ 1% of full-scale reading  
 Internal burden resistance: ..... 226  $\Omega$

**PULSE OUTPUT**

Parameters: ..... +kWh, –kWh, +kvarh, –kvarh, kVAh  
 Interval: ..... 1 to 65000 in steps of 1  
 Pulse width: ..... 100 to 2000 ms in steps of 10  
 Minimum pulse interval: ..... 500 ms  
 Accuracy: .....  $\pm$ 10 ms

**PULSE INPUT**

Max. inputs: ..... 4  
 Min. pulse width: ..... 150 ms  
 Min. off time: ..... 200 ms

## Trace Memory Trigger

**TRACE MEMORY TRIGGER**

Input ..... 2 data cycles (current, voltage)  
 Time delay: ..... 0 to 30 cycles  
 Current input full scale: ..... 150% of CT primary  
 Voltage input full scale: ..... 600 V AC

**TRIGGER LEVEL PICKUP ACCURACY**

Overcurrent: .....  $\pm$ 2% of full scale  
 Overvoltage: .....  $\pm$ 2% of full scale  
 Undervoltage: .....  $\pm$ 3% of full scale



Voltage THD: .....  $\pm 2.0\%$  of full-scale  
 Crest factor: .....  $\pm 0.4\%$  of full-scale

**MEASURED VALUES RANGE**

Voltage: ..... 20 to 100% of VT  
 Current: ..... 1 to 150% of CT  
 Voltage unbalance: ..... 0 to 100%  
 Current unbalance: ..... 0 to 100%  
 Real power: ..... 0 to  $\pm 999,999.99$  kW  
 Reactive power: ..... 0 to  $\pm 999,999.99$  kvar  
 Apparent power: ..... 0 to 999,999.99 kVA  
 Real energy: .....  $2^{32}$  kWh  
 Reactive energy: .....  $2^{32}$  kvarh  
 Apparent energy: .....  $2^{32}$  kVAh  
 Power factor: ..... 0.00 to  $\pm 1.00$   
 Frequency: ..... 20.00 to 70.00 Hz  
 kw demand: ..... 0 to  $\pm 999,999.99$  kW  
 kvar demand: ..... 0 to  $\pm 999,999.99$  kvar  
 kVA demand: ..... 0 to 999,999.99 kVA  
 Current demand: ..... 0 to 7500 A  
 THD (current and voltage): ..... 0.0 to 100.0%  
 Crest factor: ..... 1 to 9.99

**Monitoring**

**UNDERVOLTAGE MONITORING**

Req'd voltage: .....  $> 20$  V applied in all phases  
 Pickup: .....  $0.50$  to  $0.99 \times VT$  in steps of  $0.01$   
 Dropout: .....  $103\%$  of pickup  
 Time delay: .....  $0.5$  to  $600.0$  s in steps of  $0.5$   
 Phases: ..... Any 1 / Any 2 / All 3 (programmable) have to be  $\leq$   
 pickup to operate  
 Accuracy: ..... per voltage input  
 Timing accuracy: .....  $-0 / +1$  sec.

**OVERVOLTAGE MONITORING**

Pickup: .....  $1.01$  to  $1.25 \times VT$  in steps of  $0.01$   
 Dropout: .....  $97\%$  of pickup  
 Time delay: .....  $0.5$  to  $600.0$  s in steps of  $0.5$   
 Phases: ..... Any 1 / Any 2 / All 3 (programmable) must be  $\geq$   
 pickup  
 to operate  
 Accuracy: ..... Per voltage input  
 Timing accuracy: .....  $-0 / +1$  sec.

**UNDERFREQUENCY MONITORING**

Req'd voltage: .....  $> 30$  V applied in phase A  
 Pickup: .....  $20.00$  to  $70.00$  Hz in steps of  $0.01$   
 Dropout: ..... Pickup +  $0.03$  Hz  
 Time delay: .....  $0.1$  to  $10.0$  s in steps of  $0.1$   
 Accuracy: .....  $0.02$  Hz  
 Timing accuracy:  $\pm 100$  ms

**OVERFREQUENCY MONITORING**

Req'd voltage: .....  $> 30$  V applied in phase A



**CONTROL POWER**

Input: ..... 90 to 300 V DC or 70 to 265 V AC at 50/60 Hz

Power: ..... nominal 10 VA, max. 20 VA

Holdup: ..... 100 ms typical (at 120 V AC / 125 V DC)

**It is recommended that the PQM II be powered up at least once per year to avoid deterioration of the electrolytic capacitors in the power supply.**

**FUSE TYPE/RATING**

5 × 20mm, 2.5 A, 250V

Slow blow, High breaking capacity

## Testing and Approvals

**TYPE TESTS**

TEST	REFERENCE STANDARD	TEST LEVEL
Dielectric voltage withstand	EN60255-5	2300-3700VAC
Impulse voltage withstand	EN60255-5	5KV
Insulation resistance	EN60255-5	500VDC >100mohm
Damped Oscillatory	IEC61000-4-18/IEC60255-22-1	2.5KV CM, 1KV DM
Electrostatic Discharge	EN61000-4-2/IEC60255-22-2	Level II
RF immunity	EN61000-4-3/IEC60255-22-3	10V/m 80-1Ghz
Fast Transient Disturbance	EN61000-4-4/IEC60255-22-4	Class A and B
Surge Immunity	EN61000-4-5/IEC60255-22-5	4Kv, 2KV
Conducted RF Immunity	EN61000-4-6/IEC60255-22-6	10Vrms
Radiated & Conducted Emissions	CISPR11 /CISPR22/ IEC60255-25	Class A
Sinusoidal Vibration	IEC60255-21-1	Class 1
Shock & Bump	IEC60255-21-2	Class 1
Power magnetic Immunity	IEC61000-4-8	Level 4
Pulse Magnetic Immunity	IEC61000-4-9	Level 4
Voltage Dip & interruption	IEC61000-4-11	0,40,70,% dips,250/300cycle interrupts
Ingress Protection	IEC60529	IP40 front, IP20 Back
Environmental (Cold)	IEC60068-2-1	-10C 16 hrs
Environmental (Dry heat)	IEC60068-2-2	70C 16hrs
Relative Humidity Cyclic	IEC60068-2-30	6day variant 2
EFT	IEEE/ANSI C37.90.1	4KV, 2.5Khz
Damped Oscillatory	IEEE/ANSI C37.90.1	2.5KV,1Mhz
Altitude:	2000m (max)	

Pollution Degree:	II	
Overvoltage Category:	II	
Ingress protection:	IP40 Front, IP20 back	

**APPROVALS**

	Applicable Council Directive	According to
CE compliance	Low voltage directive	EN60255-5
	EMC Directive	EN61000-6-2
North America	cULus e83849 NKCR/7	UL508
		UL1053
		C22.2.No 14
ISO	Manufactured under a registered quality program	ISO9001

**ENVIRONMENTAL**

Ambient temperatures:	
Operating range:	-10C to 60C
Humidity:	Operating up to 95% (non condensing) @ 55C (As per IEC60068-2-30 Variant 2, 6days)
Ventillation:	No special ventilation required as long as ambient temperature remains within specifications. Ventilation may be required in enclosures exposed to direct sunlight.
Cleaning:	May be cleaned with a damp cloth.

**PRODUCTION TESTS**

Dielectric Strength:.....2200 VAC for 1 second (as per UL & CE)

**Physical****PACKAGING**

Shipping box: ..... 8½" × 6" × 6" (L × H × D)  
21.5cm × 15.2cm × 15.2 cm



# PQM II Power Quality Meter

## Chapter 2: Installation

### Physical Configuration

#### Mounting

Physical dimensions and required cutout dimensions for the PQM II are shown below. Once the cutout and mounting holes are made in the panel, use the eight #6 self-tapping screws provided to secure the PQM II. Mount the unit on a panel or switchgear door to allow operator access to the keypad and indicators.

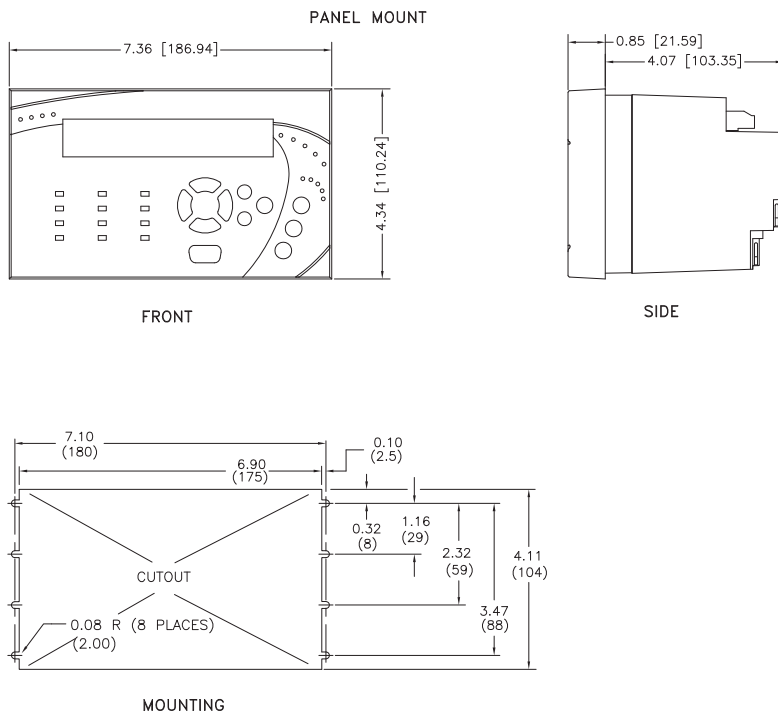

**FIGURE 2-1: Physical Dimensions**

## Product Identification

Product attributes vary according to the configuration and options selected on the customer order. Before applying power to the PQM II, examine the label on the back and ensure the correct options are installed.

The following section explains the information included on the label shown below:

PQM II			MODEL NO.: PQMII-T20-C-A				VERSION: 100.000				
MAXIMUM CONTACT RATING 250 VAC 10A RESISTIVE 1/4HP 250VAC 1/2HP 125VAC <small>MADE IN CANADA</small>			CONTROL VOLTAGE: 90-300VDC 20VA				SERIAL No.: C7360001				
			70-265VAC 50/60HZ 20VA								
			CUSTOMER TAG No.: 1234-567-89								
9	10	11	12	13	14	15	16	17	18	19	20

FIGURE 2-2: Product Label

- **Model No:** Shows the PQM II configuration. The model number for a basic panel mount PQM II is “PQMII”. T20, C, and A appear in the model number only if the Transducer, Control, or Power Analysis options are installed.
- **Supply Voltage:** Indicates the power supply input configuration installed in the PQM II. The PQM II shown in this example can accept any AC 50/60Hz voltage from 70 to 265 V AC or DC voltage from 90 to 300 V DC.
- **Tag#:** An optional identification number specified by the customer.
- **Mod#:** Indicates if any unique features have been installed for special customer orders. This number should be available when contacting GE Vernova for technical support.
- **Version:** An internal GE Vernova number that should be available when contacting us for technical support.
- **Serial No.:** Indicates the serial number in numeric and barcode formats. Record this number when contacting GE Vernova for technical support.

## Manual and Firmware Revisions

Each instruction manual revision corresponds to a particular firmware revision. The manual revision is located on the title page as part of the manual part number (the format is 1601-nnnn-*revision*). The firmware revision is located on that same page, just above the manual part number, and is also loaded in the PQM II, where it can be viewed by scrolling to the [A4 PRODUCT INFO](#) ⇨ ⇩ [SOFTWARE VERSIONS](#) ⇨ ⇩ [MAIN PROGRAM VERSION](#) message.

When using the instruction manual to determine PQM II features and settings, ensure that the instruction manual revision corresponds to the firmware revision installed in the PQM II.

# Electrical Configuration

## External Connections

Signal wiring is to Terminals 21 to 51. These terminals accommodate wires sizes up to 12 gauge. Please note that the maximum torque that can be applied to terminals 21 to 51 is 0.5 Nm (or 4.4 in ·lb.). CT, VT, and control power connections are made using Terminals 1 to 20. These #8 screw ring terminals accept wire sizes as large as 8 gauge. Consult the wiring diagrams for suggested wiring. A minimal configuration includes connections for control power, phase CTs/VTs, and the alarm relay; other features can be wired as required. Considerations for wiring each feature are given in the sections that follow.

**Table 1: PQM II External Connections**

Terminal	Description	Terminal	Description
<b>VT / Control Power Row (1 to 8)</b>		25	Analog out 4+
1	V1 Voltage input	26	Analog out 3+
2	V2 Voltage input	27	Analog out 2+
3	V3 Voltage input	28	Analog out 1+
4	Vn Voltage input	29	Switch 4 input
5	Filter ground	30	Switch 3 input
6	Safety ground	31	Switch 2 input
7	Control neutral (-)	32	Switch 1 input
8	Control live (+)	33	+24 V DC switch com
<b>CT Row (9 to 20)</b>		34	Aux3 relay NC
9	Phase A CT 5A	35	Aux3 relay COM
10	Phase A CT 1A	36	Aux3 relay NO
11	Phase A CT COM	37	Aux2 relay NC
12	Phase B CT 5A	38	Aux2 relay COM
13	Phase B CT 1A	39	Aux2 relay NO
14	Phase B CT COM	40	Aux1 relay NC
15	Phase C CT 5A	41	Aux1 relay COM
16	Phase C CT 1A	42	Aux1 relay NO
17	Phase C CT COM	43	Alarm relay NC
18	Neutral CT 5A	44	Alarm relay COM
19	Neutral CT 1A	45	Alarm relay NO
20	Neutral CT COM	46	Comm 1 COM

**Table 1: PQM II External Connections**

Terminal	Description
<b>Signal Upper Row (21 to 51)</b>	
21	Analog shield
22	Analog in –
23	Analog in +
24	Analog out com

Terminal	Description
47	Comm 1 –
48	Comm 1 +
49	Comm 2 COM
50	Comm 2 –
51	Comm 2 +

## Wiring Diagrams

This wiring diagram below shows the typical 4-wire wye connection which will cover any voltage range. Select the **S2 SYSTEM SETUP** ⇒ **CURRENT/VOLTAGE CONFIGURATION** ⇒ **VT WIRING: "4 Wire Wye (3 VTs)"** setpoint

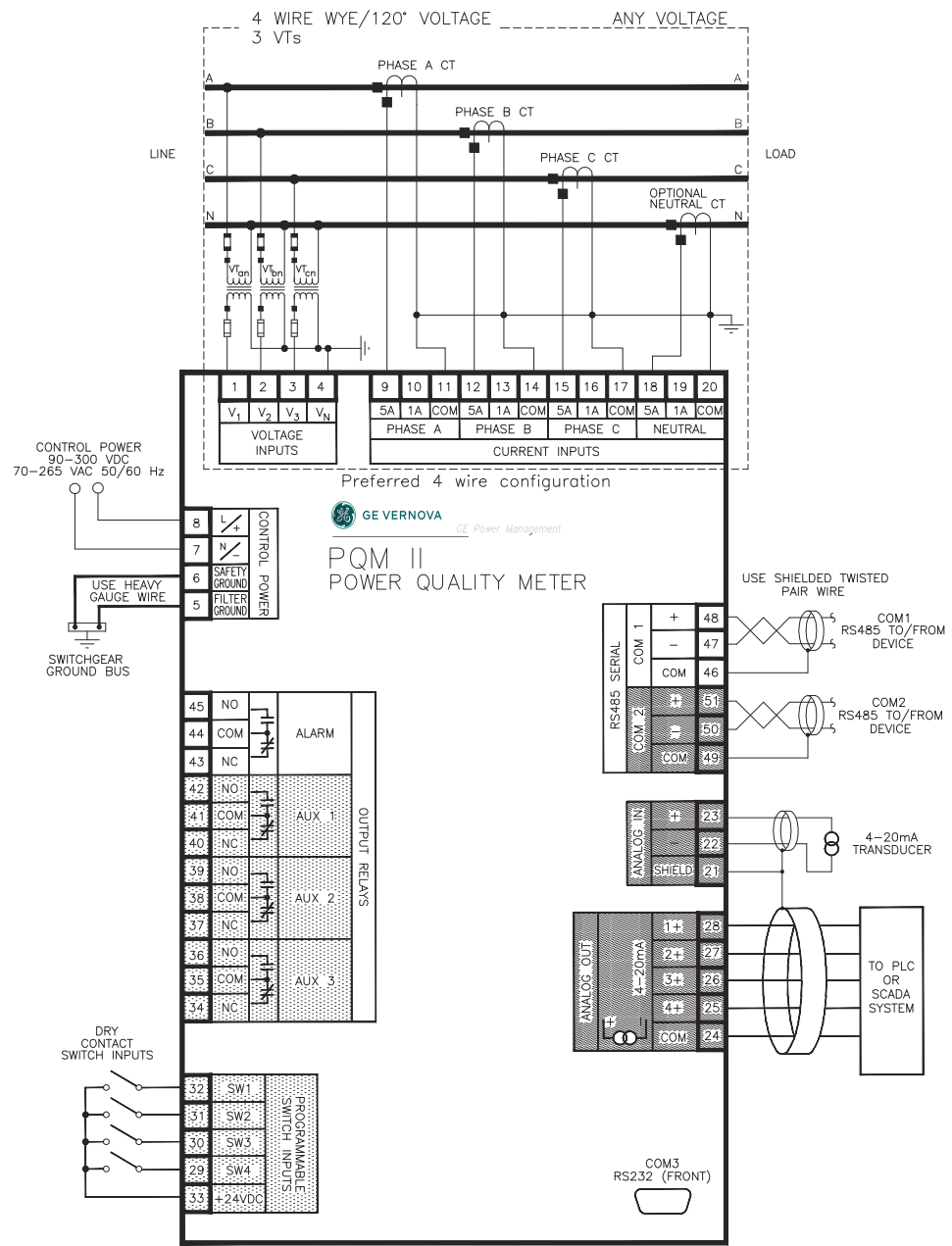

NOTES:

- Relay contact state shown with control power not applied.

CAUTION:  
USE HRC FUSES FOR VT PRIMARY TO ENSURE ADEQUATE INTERRUPTING CAPACITY.

- Transducer Option
- Control Option

748751A1.DWG

FIGURE 2-3: Wiring Diagram 4-wire Wye (3 VTs)

The 2½ element 4-wire wye connection can be used for situations where cost or size restrictions limit the number of VTs to two. With this connection, Phase Vbn voltage is calculated using the two existing voltages. Select the **S2 SYSTEM SETUP** ⇒ **CURRENT/VOLTAGE CONFIGURATION** ⇒ **VT WIRING: “4 WIRE WYE (2 VTs)”** setpoint.

This wiring configuration will only provide accurate power measurements if the voltages are balanced.

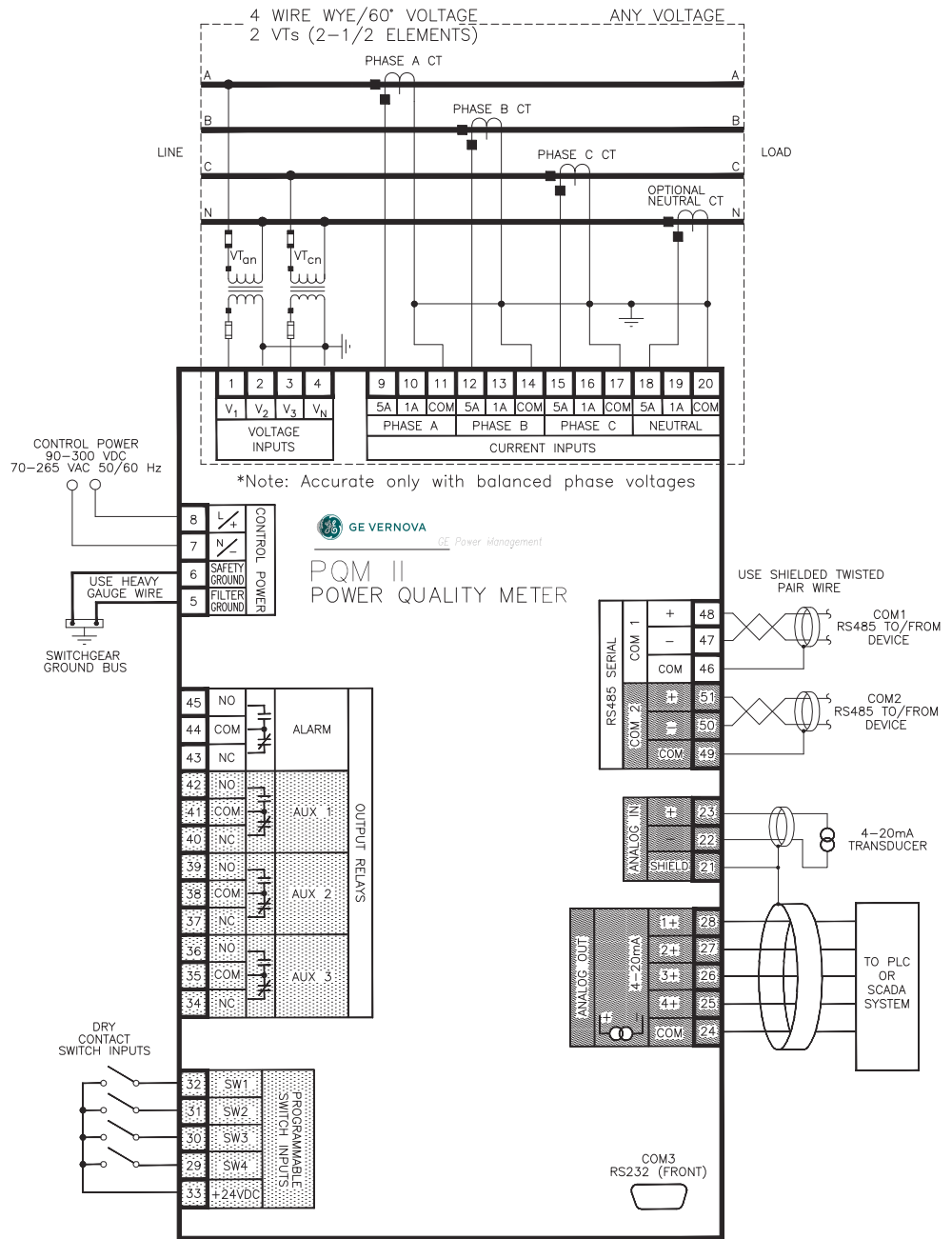

NOTES:

- 1) Relay contact state shown with control power not applied.

CAUTION: USE HRC FUSES FOR VT PRIMARY TO ENSURE ADEQUATE INTERRUPTING CAPACITY.

Transducer Option

Control Option

746752A1.DWG

FIGURE 2-4: Wiring Diagram 4-wire Wye (2 VTs)

Four-wire systems with voltages 347 V L-N or less can be directly connected to the PQM II without VTs. Select the **S2 SYSTEM SETUP** ⇒ **CURRENT/VOLTAGE CONFIGURATION** ⇒ **VT WIRING: "4 WIRE WYE DIRECT"** setpoint.

The PQM II voltage inputs should be directly connected using HRC fuses rated at 2 A to ensure adequate interrupting capacity.

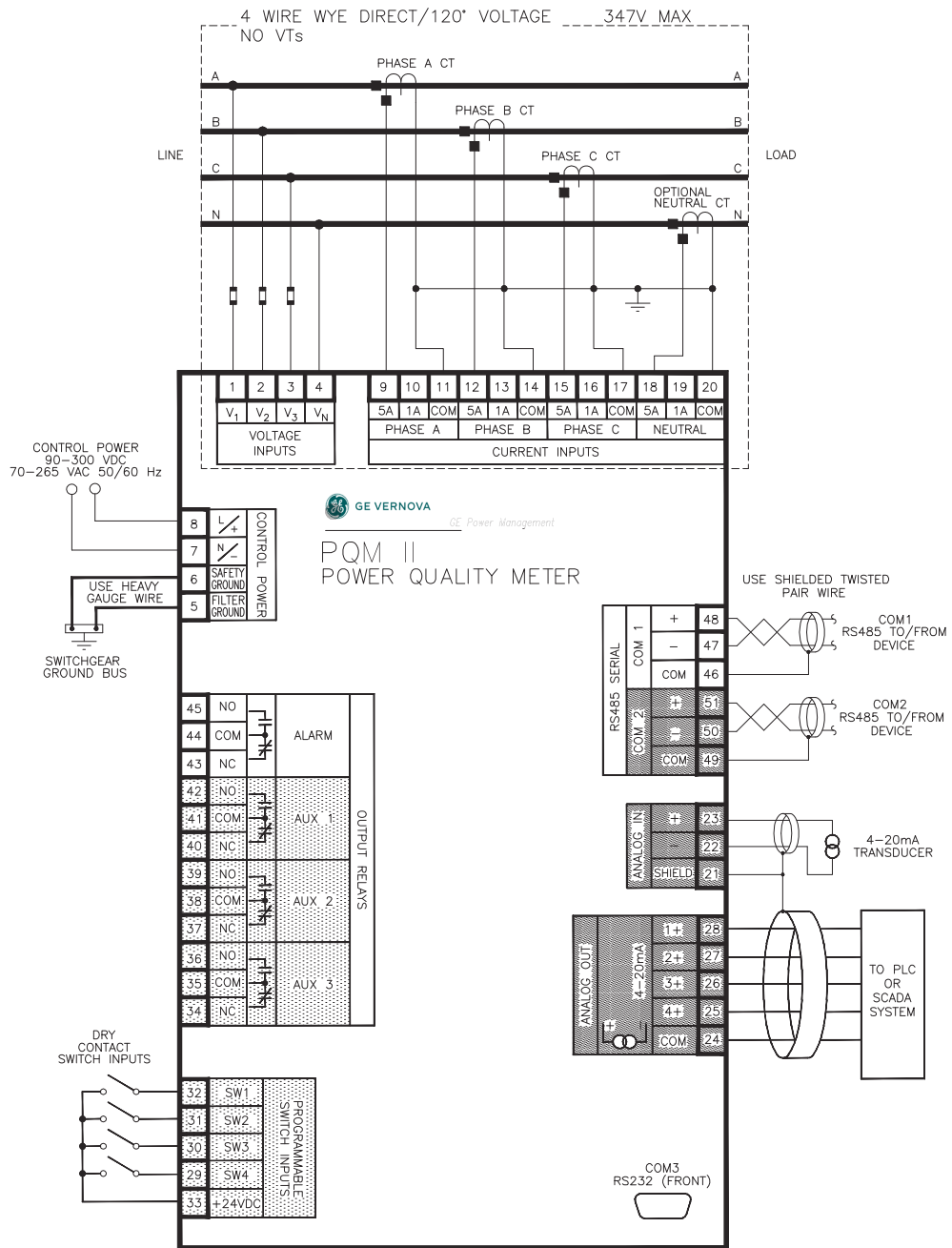

NOTES:

- Relay contact state shown with control power not applied.

CAUTION: USE HRC FUSES FOR VT PRIMARY TO ENSURE ADEQUATE INTERRUPTING CAPACITY.

- Transducer Option
- Control Option

746753A1.DWG

FIGURE 2-5: Wiring Diagram 4-wire Wye Direct (No VTs)

This diagram shows the typical 3-wire delta connection which will cover any voltage range. Select the **S2 SYSTEM SETUP** → **CURRENT/VOLTAGE CONFIGURATION** → **VT WIRING: "3 WIRE DELTA (2 VTs)"** setpoint.

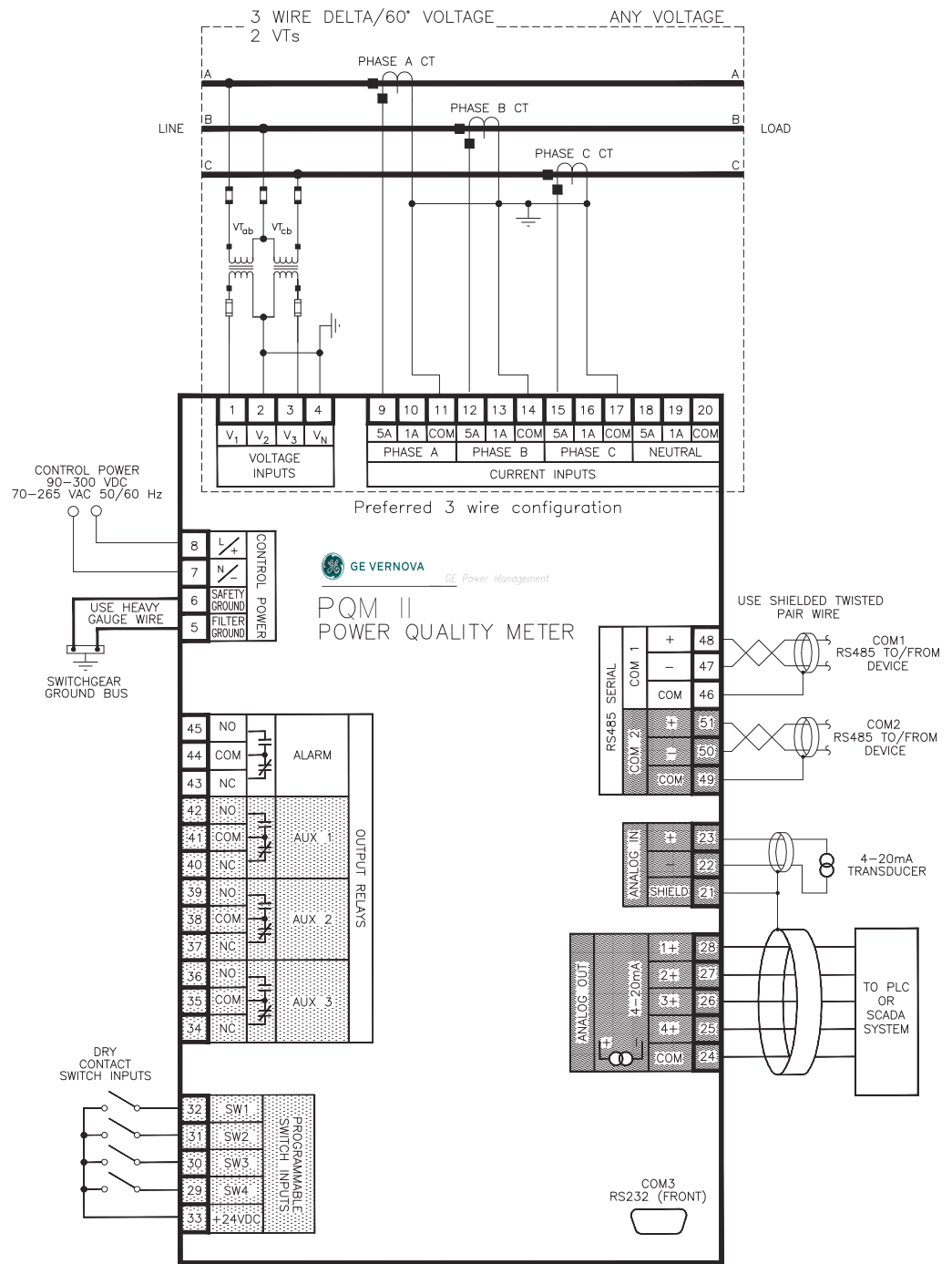

NOTES:

- 1) Relay contact state shown with control power not applied.

CAUTION: USE HRC FUSES FOR VT PRIMARY TO ENSURE ADEQUATE INTERRUPTING CAPACITY.

■ Transducer Option  
 ▨ Control Option

746754A1.DWG

FIGURE 2-6: Wiring Diagram 3-wire Delta (2 VTs)

Three-wire systems with voltages 600 V (L-L) or less can be directly connected to the PQM II without VTs. Select the **S2 SYSTEM SETUP** ⇒ **CURRENT/VOLTAGE CONFIGURATION** ⇒ **V T WIRING: "3 WIRE DIRECT"** setpoint.

The PQM II voltage inputs should be directly connected using HRC fuses rated at 2 amps to ensure adequate interrupting capacity.

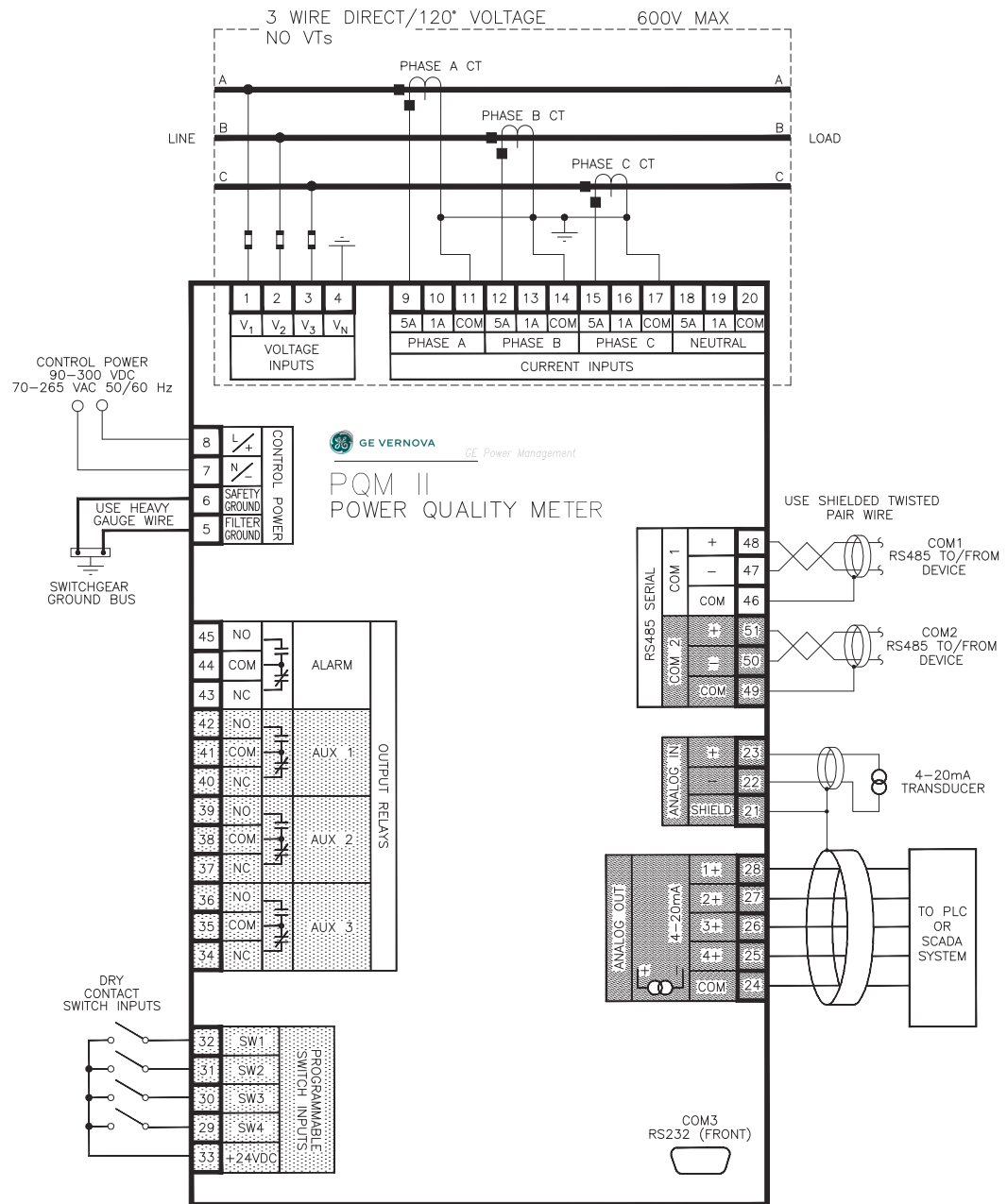

**NOTES:**

- 1) Relay contact state shown with control power not applied.

**CAUTION:** USE HRC FUSES FOR VT PRIMARY TO ENSURE ADEQUATE INTERRUPTING CAPACITY.

■ Transducer Option

▨ Control Option

746755A1.DWG

**FIGURE 2-7: Wiring Diagram 3-wire Direct (No VTs)**

For a single-phase connection, connect current and voltage to the phase A inputs only. All other inputs are ignored. Select the **S2 SYSTEM SETUP** ⇨ **CURRENT/VOLTAGE CONFIGURATION** ⇨ **VT WIRING**: “SINGLE PHASE” setpoint.

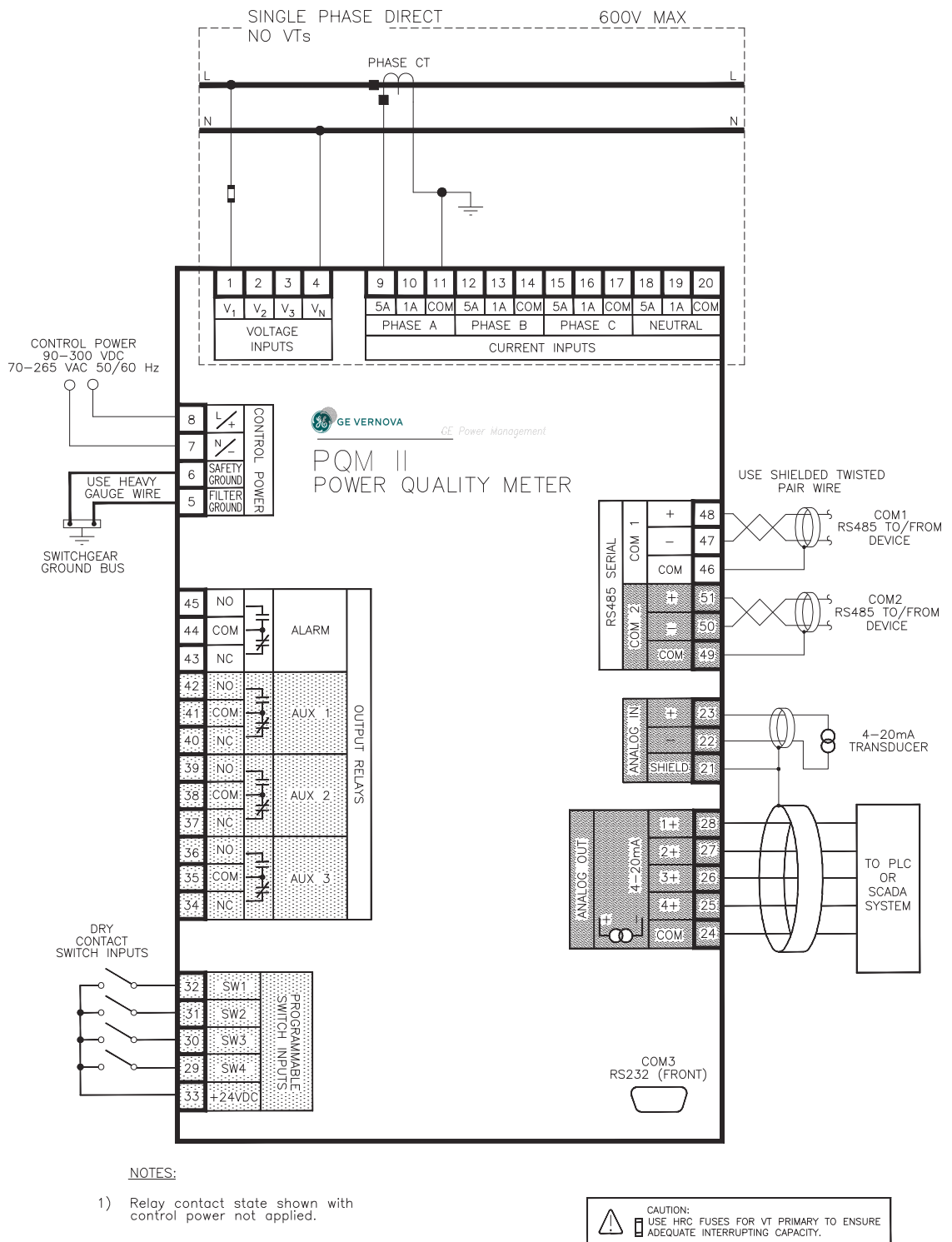

FIGURE 2-8: Single Phase Connection

### 3-wire System using Two CTs

The figure below shows two methods for connecting CTs to the PQM II for a 3-wire system. The top drawing shows the standard wiring configuration using three CTs. An alternate wiring configuration uses only two CTs. With the two CT method, the third phase is measured by connecting the commons from phase A and C to the phase B input on the PQM II. This causes the phase A and phase C current to flow through the PQM II's phase B CT in the opposite direction, producing a current equal to the actual phase B current.

$$I_a + I_b + I_c = 0 \text{ for a three wire system.}$$

$$I_b = -(I_a + I_c)$$

For the CT connections above, the **S2 SYSTEM SETUP** ⇒ **CURRENT/VOLTAGE CONFIGURATION** ⇒ **PHASE CT WIRING** ⇒ **PHASE CT PRIMARY** setpoint must be set to PHASE A, B, AND C.

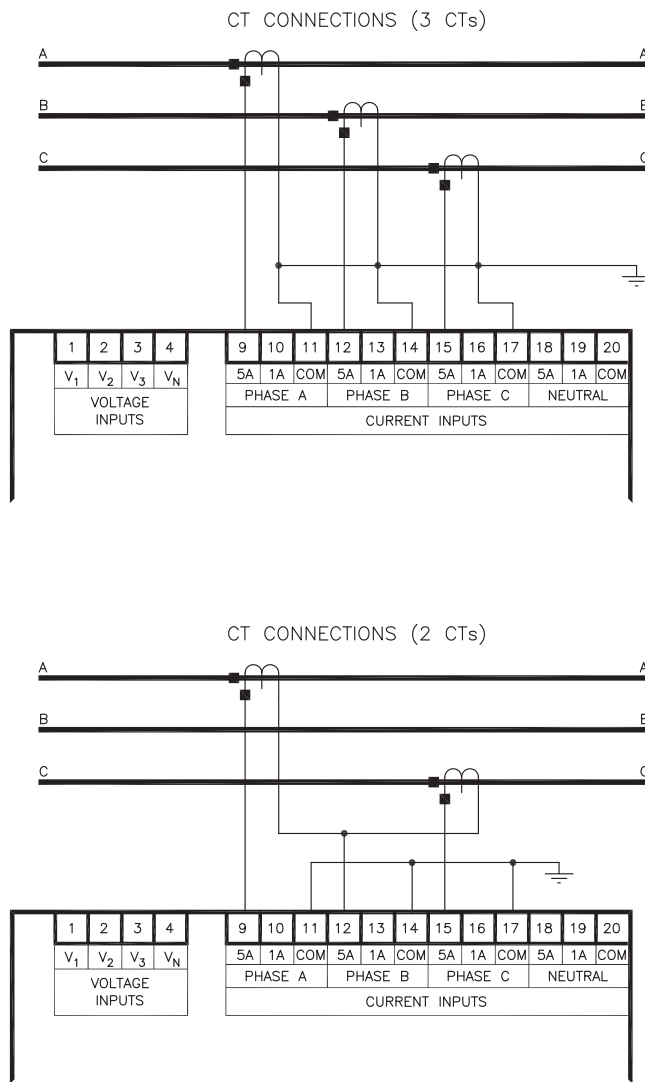

823804A2.DWG

FIGURE 2-9: Alternate CT Connections for 3-wire System

## Control Power

**The control power supplied to the PQM II must match the installed power supply. If the applied voltage does not match, damage to the unit may occur. Check the product identification to verify the control voltage matches the intended application.**

A universal AC/DC power supply is standard on the PQM II. It covers the range 90 to 300 V DC and 70 to 265 V AC at 50/60 Hz. It is not necessary to adjust the PQM II if the control voltage is within this range. A low voltage power supply is available as an option. It covers the range 20 to 60 V DC and 24 to 48 V AC at 50/60 Hz. Verify from the product identification label that the control voltage matches the intended application. Connect the control voltage input to a stable source for reliable operation. A 2.5 A HRC fuse is accessible from the back of the PQM II via the fuse access door. Consult the factory for replacement fuses, if required. Using #12 gauge wire or ground braid, connect Terminals 5 and 6 to a solid system ground, typically a copper bus in the switchgear. The PQM II incorporates extensive filtering and transient protection to ensure reliable operation under harsh industrial operating environments. Transient energy must be conducted back to the source through Filter Ground Terminal (5). The Filter Ground Terminal (5) is separated from the Safety Ground Terminal (6) to allow dielectric testing of switchgear with the PQM II wired up. Filter Ground Terminal connections must be removed during dielectric testing.

When properly installed, the PQM II meets the interference immunity requirements of IEC 801 and ANSI C37.90.1.

## VT Inputs

The PQM II accepts input voltages from 0 to 600 V AC between the voltage inputs (V1, V2, V3) and voltage common (Vn). These inputs can be directly connected or supplied through external VTs. If voltages greater than 600 V AC are to be measured, external VTs are required. When measuring line-to-line quantities using inputs V1, V2, and V3, ensure that the voltage common input Vn is grounded. This input is used as a reference for measuring the voltage inputs.

All connections to the PQM II voltage inputs should be connected using HRC fuses rated at 2 Amps to ensure adequate interrupting capacity.

## CT Inputs

Current transformer secondaries of 1 A or 5 A can be used with the PQM II for phase and neutral sensing. Each current input has 3 terminals: 5 A input, 1 A input, and common. Select either the 1 A or 5 A terminal and common to match the phase CT secondary. Correct polarity as indicated in the wiring diagrams is essential for correct measurement of all power quantities.

The CTs selected should be capable of supplying the required current to the total secondary load, including the PQM II burden of 0.1 VA at rated secondary current and the connection wiring burden.

All PQM II internal calculations are based on information measured at the CT and VT inputs. The accuracy specified in this manual assumes no error contribution from the external CTs and VTs. To ensure the greatest accuracy, Instrument class CTs and VTs are recommended.

## Output Relays

The basic PQM II comes equipped with one output relay; the control option supplies three additional output relays. The PQM II output relays have form C contacts (normally open (NO), normally closed (NC), and common (COM)). The contact rating for each relay is 5 A resistive and 5 A inductive at 250 V AC. Consult : *Specifications* for contact ratings under other conditions. The wiring diagrams show the state of the relay contacts with no control power applied; that is, when the relays are not energized. Relay contact wiring depends on how the relay operation is programmed in the [S3 OUTPUT RELAYS](#) setpoint group (see : S3 Output Relays for details).

- **Alarm Relay (Terminals 43/44/45):** A selected alarm condition activates the alarm relay. Alarms can be enabled or disabled for each feature to ensure only desired conditions cause an alarm. If an alarm is required when control power is not present, indicating that monitoring is not available, select “Fail-safe” operation for the alarm relay through the [S3 OUTPUT RELAYS](#) ⇒ [ALARM RELAY](#) ⇒ [ALARM OPERATION](#) setpoint. The NC/COM contacts are normally open going to a closed state on an alarm. If “Unlatched” mode is selected with setpoint [S3 OUTPUT RELAYS](#) ⇒ [ALARM RELAY](#) ⇒ [ALARM ACTIVATION](#), the alarm relay automatically resets when the alarm condition disappears. For “Latched” mode, the key must be pressed (or serial port reset command received) to reset the alarm relay. Refer to : *Alarms* for all the displayed alarm messages.
- **Auxiliary Relays 1,2,3 (Optional; Terminals 34 to 42):** Additional output relays can be configured for most of the alarms listed in *Alarms*. When an alarm feature is assigned to an auxiliary relay, it acts as a control feature. When the setpoint is exceeded for a control feature, the output relay changes state and the appropriate Aux LED lights but no indication is given on the display. The auxiliary relays can also be programmed to function as kWh, kvarh, and kVAh pulse outputs.

## Switch Inputs (Optional)

With the control (C) option installed the PQM II has four programmable switch inputs that can be used for numerous functions. The figure below shows the internal circuitry of the switches.

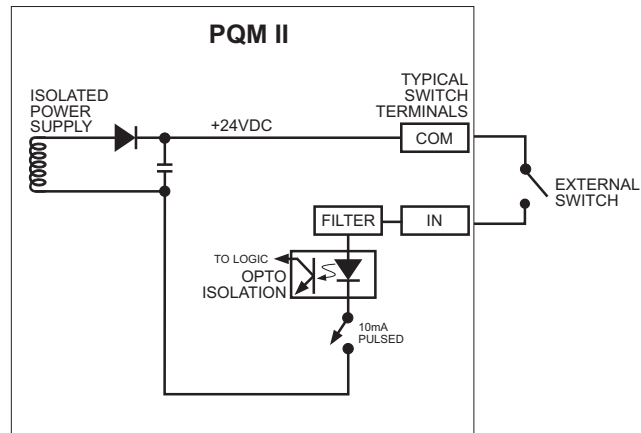

FIGURE 2-10: Switch Input Circuit

Each switch input can be programmed with a 20-character user defined name and can be selected to accept a normally open or normally closed switch. A list of various functions assignable to switches is shown below, followed by a description of each function.

- **Alarm Relay:** When a switch input is assigned to the alarm relay, a change in the switch status produces an alarm condition and the alarm relay activates.
- **Pulse Input 1/2/3/4:** When a switch input is assigned as a pulse input counter, the PQM II counts the number of transitions from open to closed when the input is configured as normally open and closed to open when the input is configured as normally closed. The minimum pulse width required for the PQM II to read the switch is 150 ms. Therefore, for the PQM II to read one pulse, the switch input must be in its inactive state (closed/open) for a minimum of 150 ms then in its active state (open/closed) for another 150 ms. See : *Specifications* for more details.
- **New Demand Period:** The PQM II can be used for load shedding by assigning a switch input to a new demand period. This allows the PQM II demand period to be synchronized with the utility meter. One of the billing parameters used by a utility is peak demand. By synchronizing the PQM II to the utility meter, the PQM II can monitor the demand level read by the utility meter and perform load shedding to prevent the demand from reaching the penalty level. The utility meter provides a dry contact output which can be connected to one of the PQM II switch inputs. When the PQM II senses a contact closure, it starts a new demand period (with Block Interval Demand calculation only).
- **Setpoint Access:** The access terminals must be shorted together in order for the faceplate keypad to have the ability to store new setpoints. Typically the access terminals are connected to a security keyswitch to allow authorized access only. Serial port commands to store new setpoints operate even if the access terminals are not shorted. When the access terminals are open, all actual and setpoint values can still be accessed for viewing; however, if an attempt is made to store a new setpoint value, the message **SETPOINT ACCESS DISABLED** is displayed and the previous setpoint remains intact. In this way, all of the programmed setpoints remain secure and tamper proof.
- **Select Analog Output:** This switch selection allows each analog output to be multiplexed into two outputs. If the switch is active, the parameter assigned in setpoint **S2 SYSTEM SETUP** ⇨ **ANALOG OUTPUT 1** ⇨ **ANALOG OUTPUT 1 ALT** determines the output level. If the switch is not active, the parameter assigned in setpoint **S2 SYSTEM**

SETUP ⇒ ANALOG OUTPUT 1 ⇒ ANALOG OUTPUT 1 MAIN is used. See the following section and : *Analog Outputs* for additional details.

- **Select Analog Input:** This switch selection allows the analog input to be multiplexed into two inputs. If the switch is active, the parameter assigned in setpoint S2 SYSTEM SETUP ⇒ ANALOG INPUT ⇒ ANALOG INPUT ALT is used to scale the input. If the switch is not active, the parameter assigned in setpoint S2 SYSTEM SETUP ⇒ ANALOG INPUT ⇒ ANALOG INPUT MAIN is used. If a relay is assigned in S2 SYSTEM SETUP ⇒ ANALOG INPUT ⇒ ANALOG IN MAIN/ALT SELECT RELAY, that relay energizes when the switch is active and de-energizes when the switch is not active, thus providing the ability to feed in analog inputs from two separate sources as shown in the figure below. See the : *Analog Input (Optional)* section below for details. Refer to : *Analog Input* for additional details.

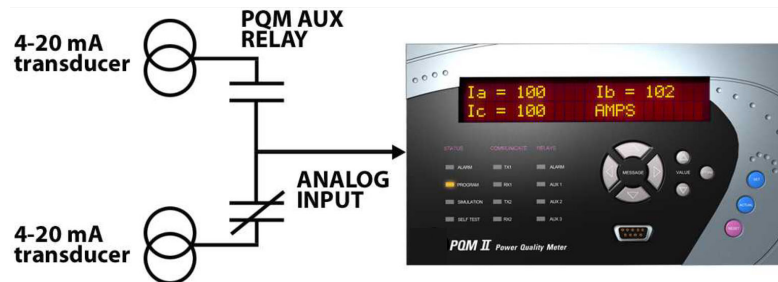

FIGURE 2-11: Analog Input Multiplexing

- **Aux 1/2/3 Relay:** When a switch input is assigned to an Auxiliary relay, a closure on the switch input causes the programmed auxiliary relay to change state. This selection is available only if the Control (C) option is installed.
- **Clear Energy:** When a switch input is assigned to “Clear Energy”, a closure on the switch input will clear all Energy data within the PGM II.
- **Clear Demand:** When a switch input is assigned to “Clear Demand”, a closure on the switch input will clear all Demand data within the PGM II.

## Analog Outputs (Optional)

The PGM II has four current outputs when the transducer option is installed (T20 = 4 to 20 mA, T1 = 0 to 1 mA in the order code). These outputs can be multiplexed to produce 8 analog transducers. This output is a current source suitable for connection to a remote meter, chart recorder, programmable controller, or computer load. Use the 4 to 20 mA option with a programmable controller that has a 2 to 40 mA current input. If only a voltage input is available, use a scaling resistor at the PLC terminals to scale the current to the equivalent voltage. For example, install a 500 Ω resistor across the terminals of a 0 to 10 V input to make the 4 to 20 mA output correspond to 2 to 10 V ( $R = V/I = 10 \text{ V} / 0.02 \text{ A} = 500 \text{ } \Omega$ ). Current levels are not affected by the total lead and load resistance which must not exceed 600 Ω for the 4 to 20 mA range and 2400 Ω for the 0 to 1 mA range. For readings greater than full scale the output will saturate at 22 mA (4 to 20 mA) or 1.1 mA (0 to 1 mA). These analog outputs are isolated and since all output terminals are floating, the connection of the analog output to a process input will not introduce a ground loop. Part of the system should be grounded for safety, typically at the programmable controller. For floating loads (such as a meter), ground Terminal 24 externally.

The outputs for these transducers can be selected from any of the measured parameters in the PQM II. The choice of output is selected in the [S2 SYSTEM SETUP](#) ⇄ [ANALOG OUTPUT 1\(4\)](#) setpoints group. See : *Analog Outputs* for a list of available parameters. Each analog output can be assigned two parameters: a main parameter and an alternate parameter. Under normal operating conditions, the main parameter will appear at the output terminals. To select the alternate parameter, one of the switch inputs must be assigned to “SELECT ANALOG OUT” and the switch input must be closed (assuming normally closed activation). By opening and closing the switch input, two analog output parameters can be multiplexed on one output. This effectively achieves 8 analog outputs for the PQM II.

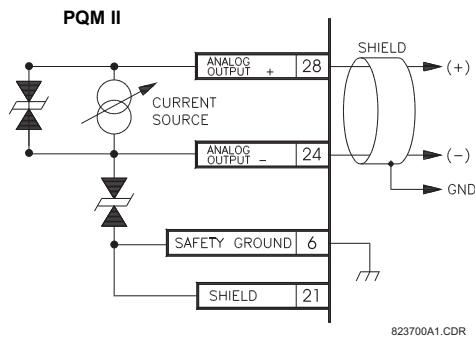

FIGURE 2-12: Analog Output

As shown in wiring diagrams, these outputs are at Terminals 25 to 28 and share Terminal 24 as their common. Shielded cable should be used, with only one end of the shield grounded, to minimize noise effects.

Signals and power supply circuitry are internally isolated, allowing connection to devices (PLCs, computers, etc.) at ground potentials different from the PQM II. Each terminal, however, is clamped to  $\pm 36$  V to ground.

## Analog Input (Optional)

Terminals 22(-) and 23(+) are provided for a current signal input. This current signal can be used to monitor any external quantity, such as transformer winding temperature, battery voltage, station service voltage, transformer tap position, etc. Any transducer output ranges within the range of 0 to 20 mA can be connected to the analog input terminals of the PQM II. See : *Analog Input* for details on programming the analog input.

## RS485 Serial Ports

A fully loaded PQM II is equipped with three serial ports. COM1 is a RS485 port available at the rear terminals of the PQM II which is normally used as the main communications interface to the system. COM2, which is also a rear RS485 port, can be used for data collection, printing reports, or problem analysis without disturbing the main communications interface. COM3 is a front panel RS232 port that can be used for setpoint programming or recording using the EnerVista PQM II Setup Software.

A serial port provides communication capabilities between the PQM II and a remote computer, PLC, or distributed control system (DCS). Up to thirty-two PQM IIs can be daisy chained together with 24 AWG stranded, shielded, twisted-pair wire on a single communication channel. Suitable wire should have a characteristic impedance of 120  $\Omega$  (such as Belden #9841). These wires should be routed away from high power AC lines and other sources of electrical noise. The total length of the communications wiring should not exceed 4000 feet for reliable operation. Correct polarity is essential for the communications port to operate. Terminal (485+) of every PQM II in a serial communication link must be connected together. Similarly, the (485-) terminal of every PQM II must also be connected together. These polarities are specified for a 0 logic and should match the polarity of the master device. If the front panel RX1 or RX2 lights are flashing, this indicates that the PQM II is receiving data. If the front panel TX1 or TX2 lights are flashing, this indicates that the PQM II is transmitting data. Each PQM II must be daisy-chained to the next one as shown in the figure below. Avoid star or stub connected configurations. If a large difference in ground potentials exists, communication on the serial communication link will not be possible. Therefore, it is imperative that the serial master and PQM II are both at the same ground potential. This is accomplished by joining the RS485 ground terminal (Terminal 46 for COM1; Terminal 49 for COM2) of every unit together and grounding it at the master only.

The last PQM II in the chain and the master computer require a terminating resistor and terminating capacitor to ensure proper electrical matching of the loads and prevent communication errors. Using terminating resistors on all the PQM IIs would load down the communication network while omitting them at the ends could cause reflections resulting in communication errors. Install the 120  $\Omega$ , 1/4 watt terminating resistor and 1 nF capacitor externally. Although any standard resistor and capacitor of these values are suitable, these components can also be ordered from GE Multilin as a combined terminating network.

Each communication link must have only one computer (PLC or DCS) issuing commands called the master. The master should be centrally located and can be used to view actual values and setpoints from each PQM II called the slave device. Other GE Multilin relays or devices using the Modbus RTU protocol can be connected to the communication link. Setpoints in each slave can also be changed from the master. Each PQM II in the link must be programmed with a different slave address prior to running communications using the [S1 PQM II SETUP](#)  $\Rightarrow$   $\Downarrow$  [COM1 RS485 SERIAL PORT](#)  $\Rightarrow$   $\Downarrow$  [MODBUS](#)

**COMMUNICATION ADDRESS** setpoint. The GE Multilin EnerVista PQM II Setup Software may be used to view status, actual values, and setpoints. See : *Using the EnerVista PQM II Setup Software* for more information on the EnerVista PQM II Setup Software.

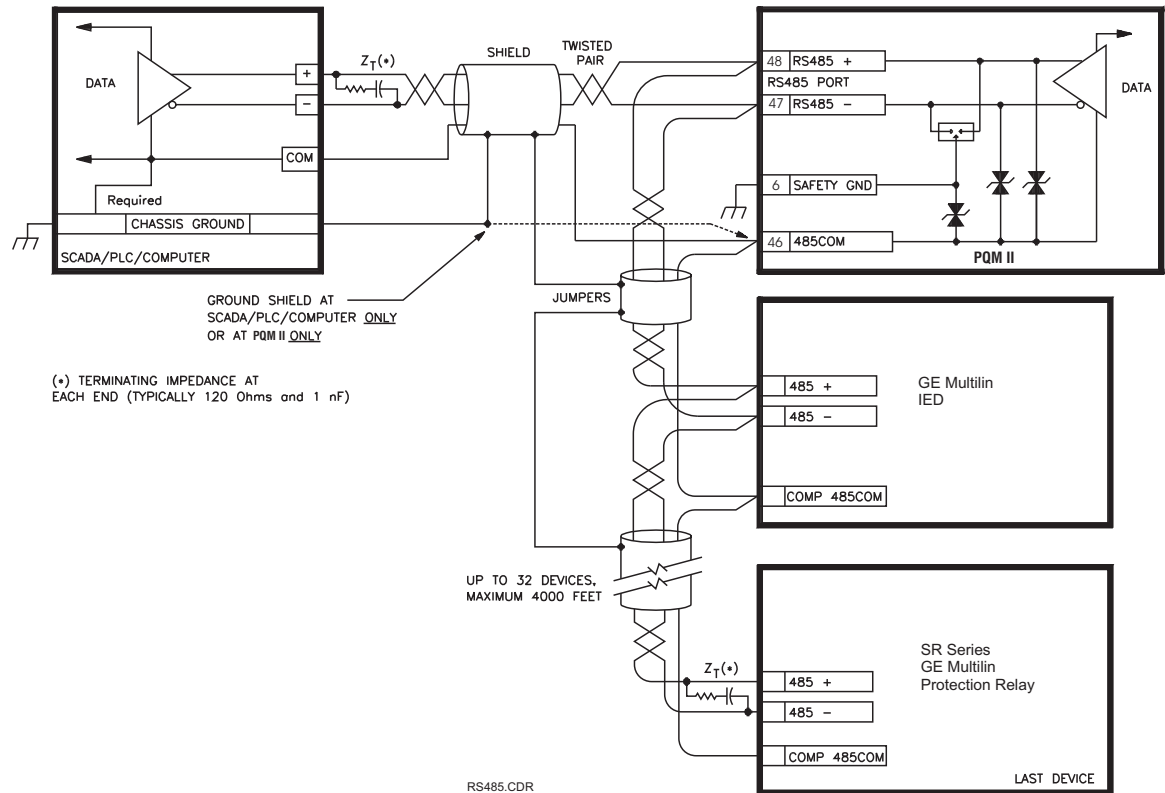

FIGURE 2-13: RS485 Communication Wiring

## RS232 Front Panel Port

A 9-pin RS232C serial port provided on the front panel allows the user to program the PQM II with a personal computer. This port uses the same communication protocol as the rear terminal RS485 ports. To use this interface, the personal computer must be running the EnerVista PQM II Setup Software provided with the relay. Cabling to the RS232 port of the computer is shown below for both 9-pin and 25-pin connectors.

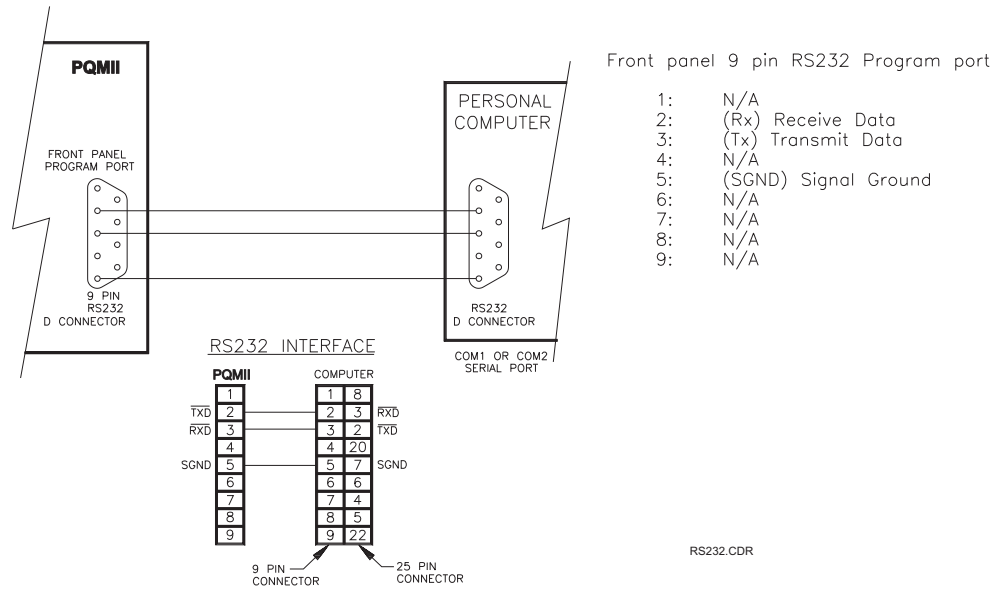

FIGURE 2-14: RS232 Connection

## Dielectric Strength Testing

It may be required to test the complete switchgear for dielectric strength with the PQM II installed. This is also known as “flash” or “hipot” testing. The PQM II is rated for 1500 V AC isolation between relay contacts, CT inputs, VT inputs, control power inputs and Safety Ground Terminal 6. Some precautions are necessary to prevent damage to the PQM II during these tests.

Filter networks and transient protection clamps are used between the control power, serial port, switch inputs, analog outputs, analog input, and the filter ground terminal 5 to filter out high voltage transients, radio frequency interference (RFI) and electromagnetic interference (EMI). The filter capacitors and transient absorbers could be damaged by the continuous high voltages relative to ground that are applied during dielectric strength testing. Disconnect the Filter Ground (Terminal 5) during testing of the control power inputs. Relay contact and CT terminals do not require any special precautions. Do not perform dielectric strength testing on the serial ports, switch inputs, analog input or analog output terminals or the PQM II internal circuitry will be damaged.

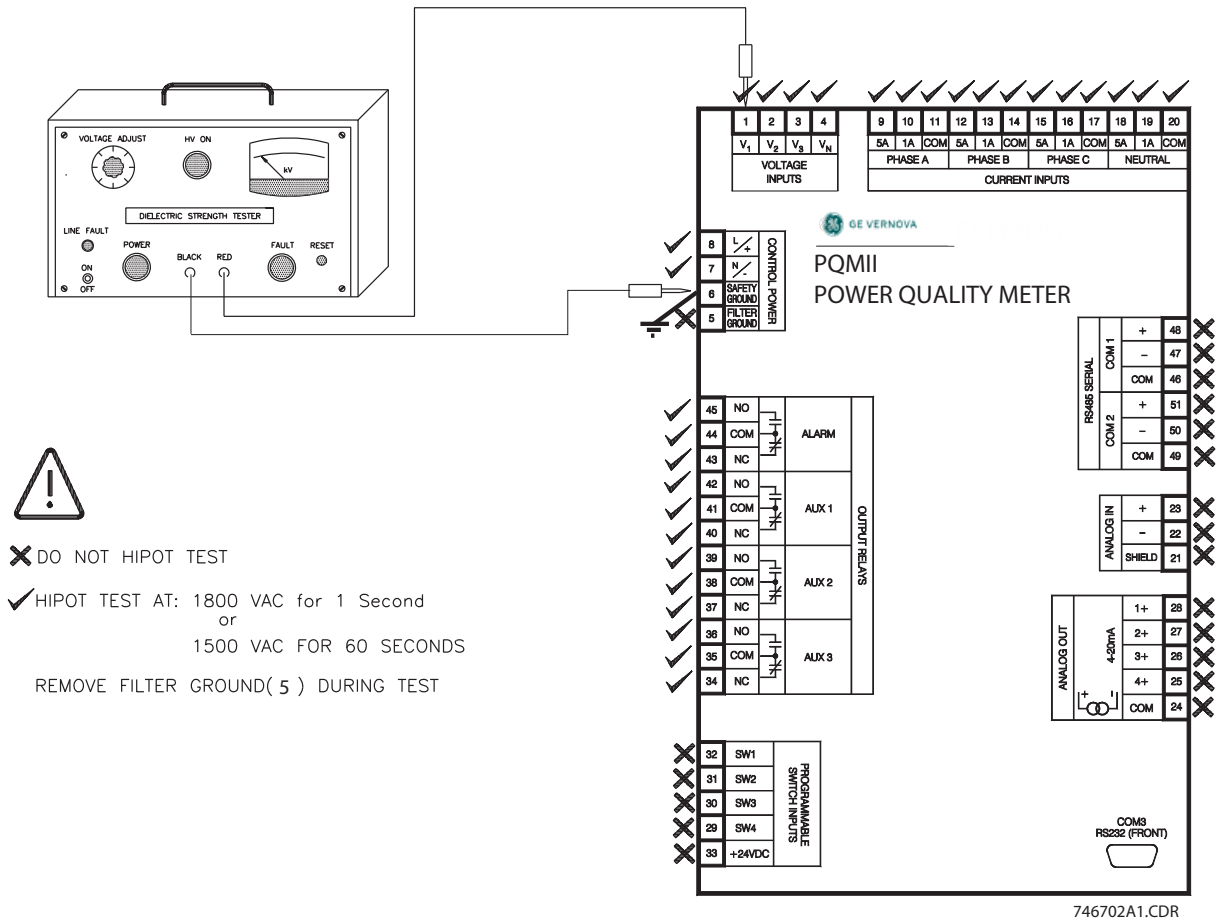

FIGURE 2-15: Hi-Pot Testing



# PQM II Power Quality Meter

## Chapter 3: Operation

---

### Front Panel and Display

#### Front Panel

The local operator interface for setpoint entry and monitoring of measured values is through the front panel as shown in the figure below. Control keys are used to select the appropriate message for entering setpoints or displaying measured values. Alarm and status messages are automatically displayed when required. Indicator LEDs provide important status information at all times. An RS232 communications port is also available for uploading or downloading information to the PQM II.

#### Display

All messages are displayed in English on the 40-character liquid crystal display. This display is visible under varied lighting conditions. When the keypad and display are not actively being used, the screen displays a default status message. This message appears if no key has been pressed for the time programmed in the [S1 PQM II SETUP](#) ⇒ [PREFERENCES](#) ⇒ [DEFAULT MESSAGE TIME](#) setpoint. Note that alarm condition messages automatically override the default messages.



FIGURE 3-1: Display (example)

# LED Indicators

## Description

The LED status indicators provide a quick indication of the overall status of the PQM II. These indicators illuminate if an alarm is present, if setpoint access is enabled, if the PQM II is in simulation mode, or if there is a problem with the PQM II itself.

STATUS	COMMUNICATE	RELAYS
■ ALARM	■ TX1	■ ALARM
■ PROGRAM	■ RX1	■ AUX1
■ SIMULATION	■ TX2	■ AUX2
■ SELF TEST	■ RX2	■ AUX3

FIGURE 3–2: LED Indicators

## Status

- **Alarm:** When an alarm condition exists, the Alarm LED indicator will flash.
- **Program:** The Program LED indicator is on when setpoint access is enabled.
- **Simulation:** The Simulation LED indicator will be on when the PQM II is using simulated values for current, voltage, analog input, switches and analog outputs. While in simulation mode, the PQM II will ignore the measured parameters detected at its inputs and will use the simulated values stored in the [SS TESTING](#) ⇄ [SIMULATION](#) setpoints group.
- **Self-Test:** Any abnormal condition detected during PQM II self-monitoring, such as a hardware failure, causes the Self Test LED indicator to be on. Loss of control power to the PQM II also causes the Self Test LED indicator to turn on, indicating that no metering is present.

## Communicate

The Communicate LED indicators monitor the status of the RS485 communication ports. When no serial data is being received through the rear serial ports terminals, the RX1/2 LED indicators are off. This situation occurs if there is no connection, the serial wires become disconnected, or the master computer is inactive. If there is activity on the serial port but the PQM II is not receiving valid messages for its internally programmed address, the TX1/2 LED indicators remain off. This condition can be caused by incorrect message formats (such as baud rate or framing), reversed polarity of the two RS485 twisted-pair connections, or the master not sending the currently programmed PQM II address. If the PQM II is being periodically addressed with a valid message, the RX1/2 LED indicator will turn on followed by the TX1/2 LED indicator.

- **TX1:** The PQM II is transmitting information via the COM1 RS485 communications port when lit.
- **RX1:** The PQM II is receiving information via the COM1 RS485 communications port when lit.

- **TX2:** The PQM II is transmitting information via the COM2 RS485 communications port when lit.
- **RX2:** The PQM II is receiving information via the COM2 RS485 communications port when lit.

## Relays

The status of the output relays is displayed with these LED indicators.

- **Alarm:** The Alarm relay is intended for general purpose alarm outputs. This indicator will be on while the Alarm relay is operating. When the condition clears, the Alarm LED indicator turns off. If the alarm relay has been programmed as “Latched”, the alarm condition can only be cleared by pressing the RESET key or by issuing a computer reset command.
- **Aux1:** The Aux 1 relay is intended for control and customer specific requirements. The Aux1 LED indicator is on while the Auxiliary 1 relay is operating.
- **Aux2:** The Aux 2 relay is intended for control and customer specific requirements. The Aux2 LED indicator is on while the Auxiliary 2 relay is operating.
- **Aux3:** The Aux 3 relay is intended for control and customer specific requirements. The Aux3 LED indicator is on while the Auxiliary 3 relay is operating.

---

## Keypad

### Description

The front panel keypad allows direct access to PQM II functionality. The keys are used to navigate through message pages, allowing the user to modify settings and view actual values from the device location.

### Menu Key

Setpoints and actual values are arranged into two distinct groups of messages. The MENU key selects the main setpoints or actual values page. Pressing MENU while in the middle of a setpoints or actual values page returns the display to the main setpoints or actual values page. The MESSAGE keys select messages within a page.

### Escape Key

Pressing the ESCAPE key during any setpoints or actual values message returns the user to the previous message level. Continually pressing ESCAPE will return the user back to the main setpoints or actual values page.

## Enter Key

When programming setpoints, enter the new value by using the VALUE keys, followed by the ENTER key. Setpoint programming must be enabled for the ENTER key to store the edited value. An acknowledgment message will flash if the new setpoint is successfully saved in non-volatile memory. The ENTER key is also used to add and remove user defined default messages. Refer to : *Default Messages* for details.

## Reset Key

The RESET key is used to clear the latched alarm and/or auxiliary conditions. Upon pressing the key, the PQM II will perform the appropriate action based on the condition present as shown in the table below.

**Table 1: Reset Key Actions**

Condition Present	Message Displayed	PQM II Action Performed
None	None	No action taken
Alarm	<b>RESET NOT POSSIBLE ALARM STILL PRESENT</b>	Alarm LED indicators and alarm relay remain on because condition is still present
Aux Relay	<b>RESET NOT POSSIBLE AUX CONDITION EXISTS</b>	Auxiliary LED indicator(s) and aux relay(s) remain on because condition is still present
Alarm and Aux Relay	<b>RESET NOT POSSIBLE AUX CONDITION EXISTS</b>	Auxiliary and Alarm LED indicators and alarm and aux relays remain on because condition is still present
Latched Alarm (condition no longer exists)	None	No message displayed, and Alarm LED indicators and the alarm relay turned off
Latched Aux Relay (condition no longer exists)	None	No message displayed, and appropriate Auxiliary LEDs and auxiliary relay(s) turned off
Alarm and Latched Aux Relay (Aux condition no longer exists)	None	No message displayed, and appropriate Auxiliary LEDs and auxiliary relay(s) turned off
Aux Relay and Latched Alarm (alarm condition no longer exists)	None	No message displayed, and Alarm LEDs and alarm relay turned off

The RESET key, along with the ENTER key, is also used to remove user defined default messages. Refer to : *Default Messages* further details.

## Message Keys

Use the MESSAGE keys to move between message groups within a page. The MESSAGE DOWN key moves toward the end of the page and the MESSAGE UP key moves toward the beginning of the page. A page header message will appear at the beginning of each page and a page footer message will appear at the end of each page. To enter a subgroup, press the MESSAGE RIGHT key. To back out of the subgroup, press the MESSAGE LEFT key.

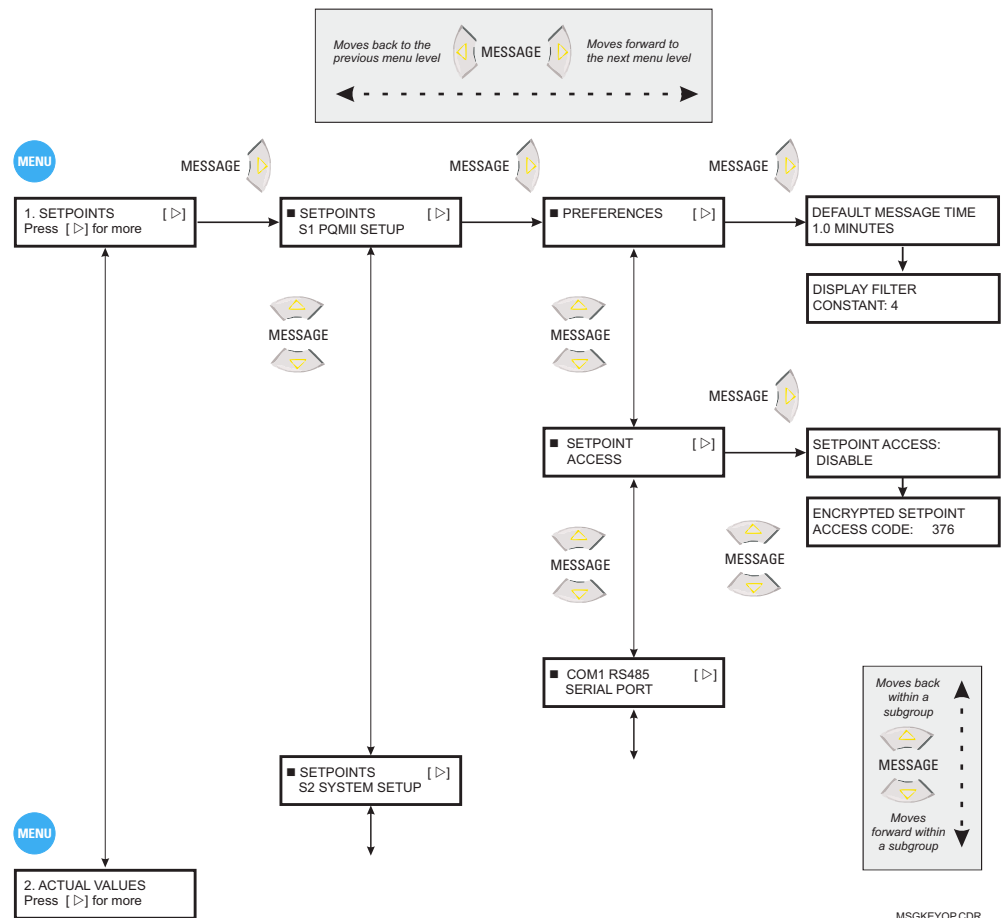

FIGURE 3-3: Message Key Operation

## Value Keys

Setpoint values are entered using the VALUE keys. When a setpoint is displayed calling for a yes/no response, each time a VALUE key is pressed, the “Yes” becomes a “No,” or the “No” becomes a “Yes.” Similarly, for multiple choice selections, each time a VALUE key is pressed, the next choice is displayed. When numeric values are displayed, each time VALUE UP is pressed, the value increases by the step increment, up to the maximum. Hold the key down to rapidly change the value.

## Data Entry Methods

- **Keypad Entry:** Press the MENU key once to display the first page of setpoints. Press the MESSAGE RIGHT key to select successive setpoints pages. The page number and page title appear on the second line. All setpoint page headers are numbered with an 'S' prefix. Actual value page headers are numbered with an 'A' prefix.

The messages are organized into logical subgroups within each Setpoints and Actual Values page as shown below.

Press the MESSAGE keys when displaying a subgroup to access messages within that subgroup. Otherwise select the MESSAGE keys to display the next subgroup.

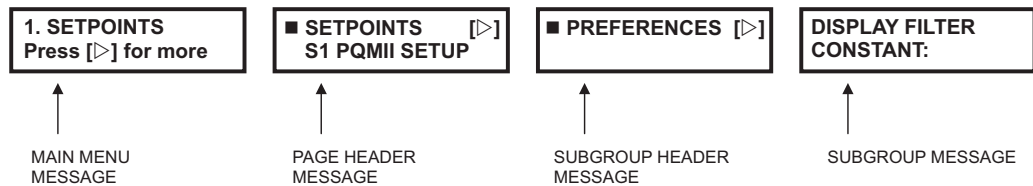

FIGURE 3-4: Message Hierarchy Example

- **Computer Entry:** When running the EnerVista PQM Setup Software, setpoint values are accessed through the menu bar and displayed in a series of windows. See Chapter 4: *Software* for further details.
- **SCADA Entry:** A SCADA system connected to the RS485 terminals can be custom programmed to make use of any of the communication commands for remote setpoint programming, monitoring, and control.

## Setpoint Access Security

The PQM II incorporates software security to provide protection against unauthorized setpoint changes. A numeric access code must be entered to program new setpoints using the front panel keys. To enable the setpoint access security feature, the user must enter a value in the range of 1 to 999. The factory default access code is 1. If the switch option is installed in the PQM II, a hardware jumper access can be assigned to a switch input. Setpoint access can then only be enabled if the switch input is shorted and the correct software access code entered. Attempts to enter a new setpoint without the electrical connection across the setpoint access terminals or without the correct access code will result in an error message. When setpoint programming is via a computer, no setpoint access jumper is required. If a SCADA system is used for PQM II programming, it is up to the programmer to design in appropriate passcode security.

## Default Messages

### Description

Up to 10 default messages can be selected to display sequentially when the PQM II is left unattended. If no keys are pressed for the default message time in the **S1 PQM II SETUP** ⇒ **PREFERENCES** ⇒ **DEFAULT MESSAGE TIME** setpoint, then the currently displayed message will automatically be overwritten by the first default message. After three seconds, the next default message in the sequence will display if more than one is selected. Alarm messages will override the default message display. Any setpoint or measured value can be selected as a default message.

Messages are displayed in the order they are selected.

### Adding a Default Message

Use the MESSAGE keys to display any setpoint or actual value message to be added to the default message queue and follow the steps shown below. When selecting a setpoint message for display as a default, do not modify the value using the VALUE keys or the PQM II will recognize the ENTER key as storing a setpoint instead of selecting a default message



If 10 default messages are already selected, the first message is erased and the new message is added to the end of the queue.

### Deleting a Default Message

Use the MESSAGE keys to display the default message to be erased. If default messages are not known, wait until the PQM II starts to display them and then write them down. Use the MESSAGE keys to display the setpoint or actual value message to be deleted from the default message queue and follow the steps below.

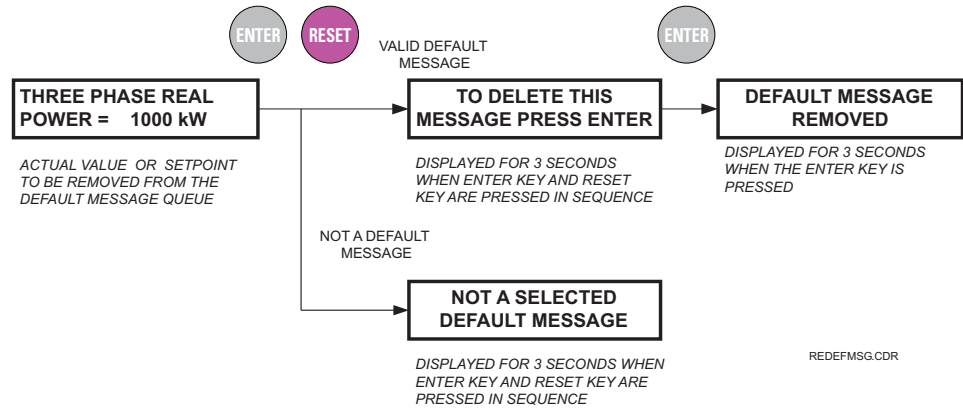

### Default Message Sequence

Each PQM II is pre-programmed with five default messages as shown below. Note, each time the factory setpoints are reloaded the user programmed default messages are overwritten with these messages.

The PQM II will scroll through the default messages in the sequence shown.

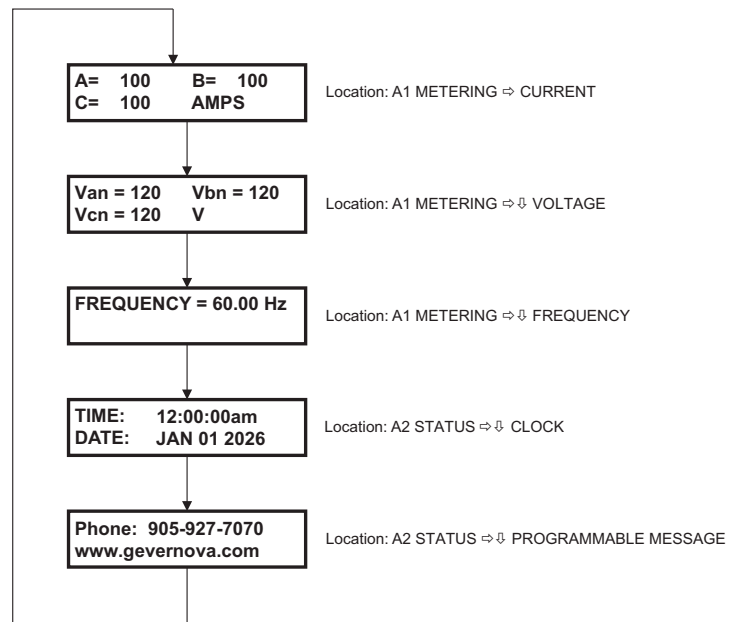

# PQM II Power Quality Meter

## Chapter 4: Software

---

## Introduction

### Overview

Although setpoints can be manually entered using the front panel keys, it is far more efficient and easier to use a computer to download values through the communications port. The no-charge EnerVista PQM II Setup Software included with the PQM II makes this a quick and convenient process. With the EnerVista PQM II Setup Software running on your PC, it is possible to:

- Program and modify setpoints
- Load/save setpoint files from/to disk
- Read actual values and monitor status
- Perform waveform capture and log data
- Perform harmonic analysis
- Trigger trace memory
- Get help on any topic

The EnerVista PQM II Setup Software allows immediate access to all the features of the PQM II through pull-down menus in the familiar Windows environment. The software can also run without a PQM II connected. This allows you to edit and save setpoint files for later use. If a PQM II is connected to a serial port on a computer and communication is enabled, the PQM II can be programmed from the setpoint screens. In addition, measured values, status and alarm messages can be displayed with the actual screens.

### Hardware

EnerVista PQM II Setup Software connects to the PQM II via RS232, RS485, or Ethernet (requires the Multinet FE Serial to Ethernet adapter) communications.

The following figures below illustrate typical connections for RS232 and RS485 communications.

For more details on Ethernet communications, please see the Multinet FE Instruction manual (<https://www.governova.com/grid-solutions/automation/critical-infrastructure-communications/multinet-fe>).

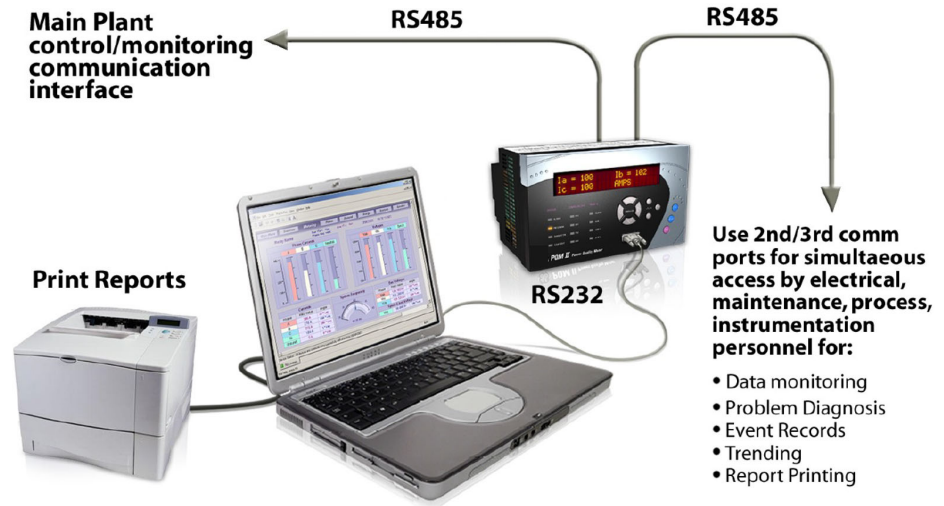

FIGURE 4-1: Communications using The Front RS232 Port

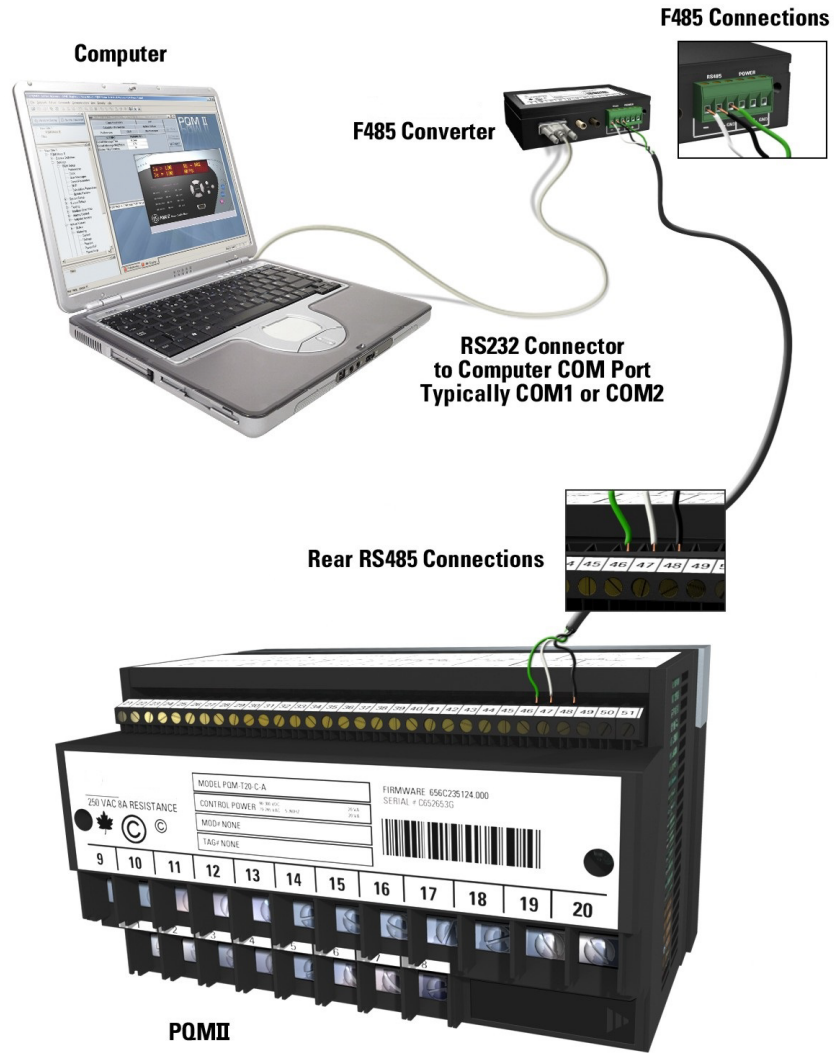

FIGURE 4–2: Communications using Rear RS485 Port

## Installing the EnerVista PQM II Setup Software

The latest EnerVista PQM II setup software can be downloaded from the GE Vernova website at: <https://www.governova.com/grid-solutions/automation/protection-control-metering/pqm-ii>

After downloading the installation package run the software installer to install the software on a Windows based workstation.

- Once the download is complete, double-click the installation program to install the EnerVista PQM Setup Software.
- Click the CONTINUE WITH PQM II VERSION 2.35 INSTALLATION button.
- Select the complete path, including the new directory name, where the EnerVista PQM II Setup Software will be installed.

- Click Next to begin the installation.
- The files will be installed in the directory indicated and the installation program will automatically create icons and add EnerVista PQM II Setup Software to the Windows start menu.

---

## Configuring Serial Communications

### Description

Before starting, verify that the serial cable is properly connected to either the RS232 port on the front panel of the device (for RS232 communications) or to the RS485 terminals on the back of the device (for RS485 communications). See : *Hardware* for connection details.

- ▷ Install and start the latest version of the EnerVista PQM II Setup Software. See the previous section for the installation procedure.
- ▷ Click on the **Device Setup** button to open the Device Setup window.
- ▷ Click the **Add Site** button to define a new site.
- ▷ Enter the desired site name in the **Site Name** field. If desired, a short description of site can also be entered along with the display order of devices defined for the site.
- ▷ Click the **OK** button when complete.  
The new site will appear in the upper-left list in the EnerVista PQM II Setup Software window.
- ▷ Click the **Add Device** button to define the new device.
- ▷ Enter the desired name in the **Device Name** field and a description (optional) of the site.
- ▷ Select “Serial” from the Interface drop-down list.  
This will display a number of interface parameters that must be entered for proper RS232 functionality.
- ▷ Enter the relay slave address and COM port values (from the [S1 PQM II SETUP](#) ⇒ [FRONT PANEL RS232 SERIAL PORT](#) setpoints menu) in the Slave Address and COM Port fields.
- ▷ Enter the physical communications parameters (baud rate and parity settings) in their respective fields.
- ▷ Click the **Read Order Code** button to connect to the PQM II device and upload the order code.  
If a communications error occurs, ensure that the PQM II serial communications values entered in the previous step correspond to the relay setting values.
- ▷ Click **OK** when the relay order code has been received.  
The new device will be added to the Site List window (or Online window) located in the top left corner of the main EnerVista PQM II Setup Software window.

The PQM II Site Device has now been configured for serial communications.

---

## Upgrading Firmware

### Description

To upgrade the PQM II firmware, follow the procedures listed in this section. Upon successful completion of this procedure, the PQM II will have new firmware installed with the original setpoints.

The latest firmware files are available from the GE Vernova website at <http://www.gevernova.com/grid-solutions>.

### Saving Setpoints to a File

Before upgrading firmware, it is important to save the current PQM II settings to a file on your PC. After the firmware has been upgraded, it will be necessary to load this file back into the PQM II.

- ▷ To save setpoints to a file, select the **File > Read Device Settings** menu item. The EnerVista PQM II Setup Software will read the device settings and prompt the user to save the setpoints file.
- ▷ Select an appropriate name and location for the setpoint file.
- ▷ Click **OK**. The saved file will be added to the “Files” pane of the EnerVista PQM II Setup Software main window.

### Loading New Firmware

- ▷ Select the **Commands > Upgrade Firmware** menu item. A warning will appear.
- ▷ Select **Yes** to proceed or **No** to abort the process. Do not proceed unless you have saved the current setpoints as shown in the previous section.



- ▷ Locate the firmware file to load into the PQM II.  
The firmware filename has the following format:

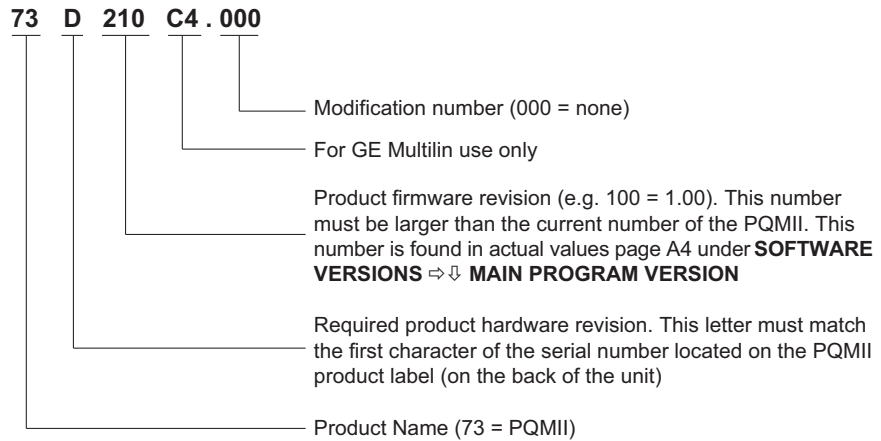

- ▷ Select the required file.
- ▷ Click on **OK** to proceed or **Cancel** to abort the firmware upgrade.

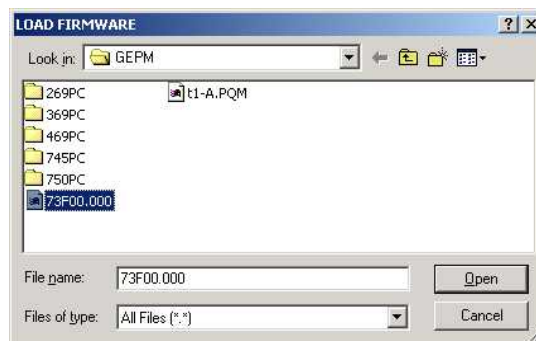

One final warning will appear. This will be the last chance to abort the firmware upgrade.

- ▷ Select **Yes** to proceed, **No** to load a different file, or **Cancel** to abort the process.



The EnerVista PQM II Setup Software now prepares the PQM II to receive the new firmware file. The PQM II will display a message indicating that it is in Upload Mode. While the file is being loaded into the PQM II, a status box appears showing how much of the new firmware file has been transferred and how much is remaining. The entire transfer process takes approximately five minutes.

The EnerVista PQM II Setup Software will notify the user when the PQM II has finished loading the file.

- ▷ Carefully read any displayed messages and click **OK** to return the main screen.

If the PQM II does not communicate with the EnerVista PQM II Setup Software, ensure that the following PQM II setpoints correspond with the EnerVista PQM II Setup Software settings:

MODBUS	COMMUNICATION	ADDRESS
BAUD		RATE
PARITY (if applicable)		

Also, ensure that the correct COM port is being used.

## Converting PQM Setting Files below v3.60 for import into the PQM II v2.35 Setup Software

To import setting files older than PQM v3.60 in the PQM II v2.35 Setup software, the files must be converted. There are two tasks involved in the conversion.

For completing each task: Task 1 and 2, see the following detailed steps.

### Task 1: Convert the PQM settings file from a file lower than v3.60 to v3.60

1. Launch the PQM PC Setup Software.
2. Open the settings file older than PQM v3.60 in the PQMPC Setup Software.
3. Under **File -> File/Properties**, change the Version to 3.6X.

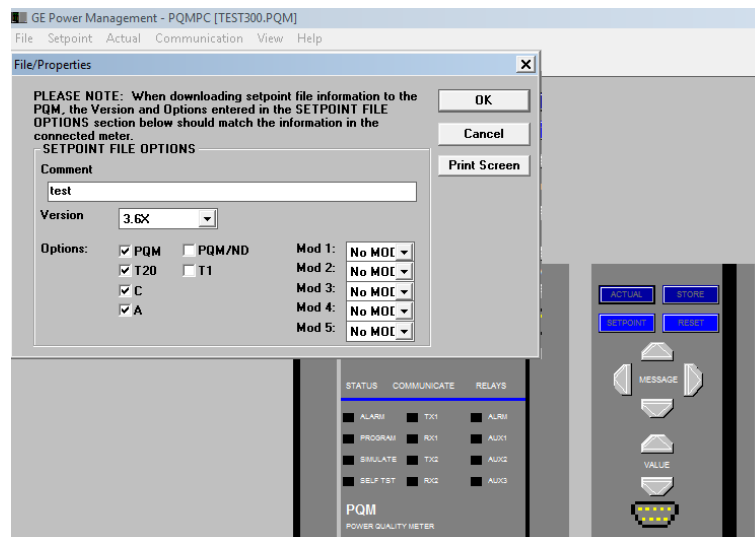

4. Press **Save** to save the file.

### Task 2: Import the converted PQM v3.60 settings file (from Task 1) into the PQM II v2.35 Setup Software

5. Launch the PQM II v2.35 Setup Software.

6. Right click in the offline tree area of PQM II v2.35 and select "Add Existing Settings File" from the menu as shown in the following screen shot.

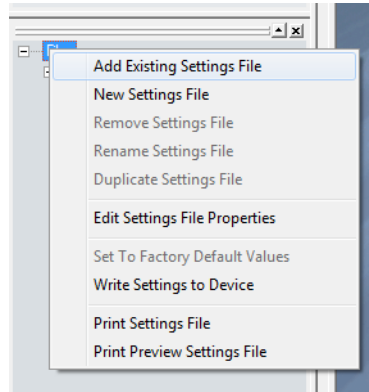

7. Select the PQM file which was created and saved in Task 1.
8. PQM II v2.35 Setup Software prompts for confirmation:

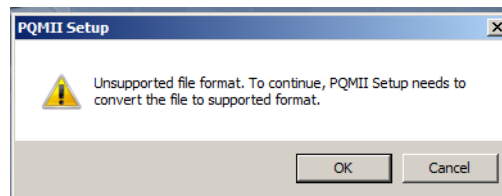

9. Click on OK button. The Save As dialog box for the converted file appears.

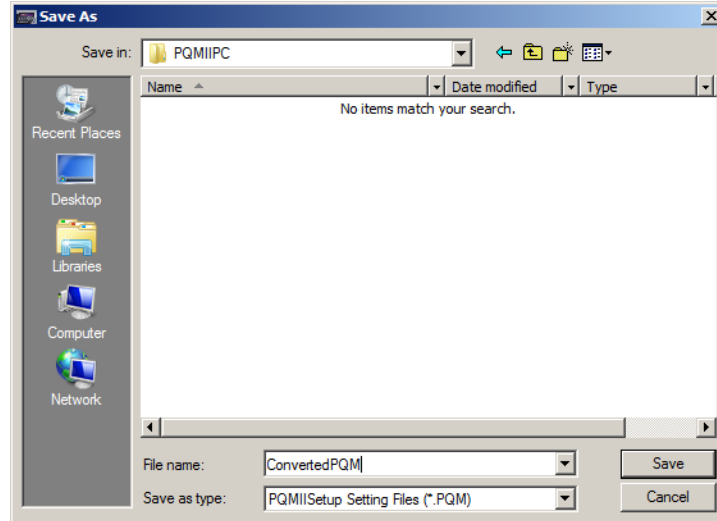

10. Enter a new File name and ensure the Save as Type is "PQM II Setup Setting Files (\*.PQM)".

11. Click on the **Save** button. The file is converted and added to the offline tree.

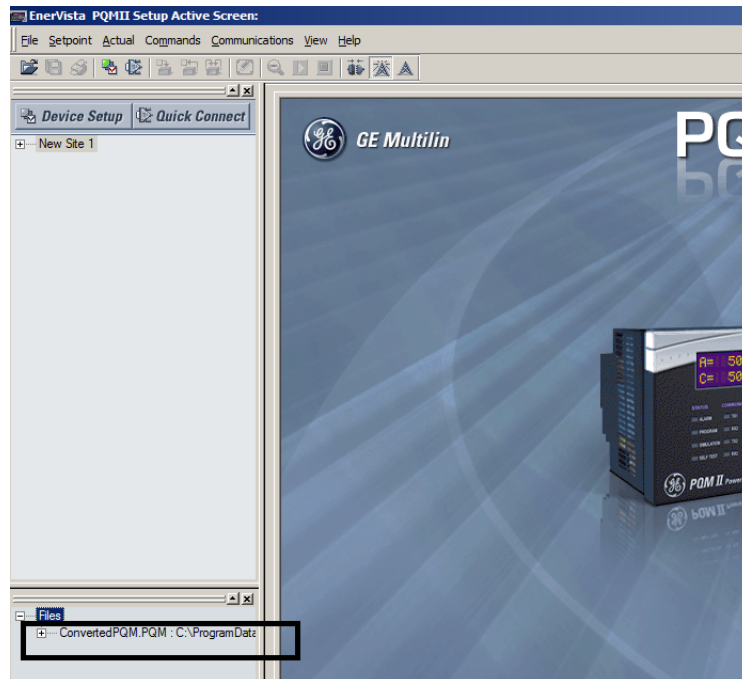

## Loading Saved Setpoints

- ▷ Select the previously saved setpoints file from the File pane of the EnerVista PQM II Setup Software main window.
- ▷ Select the setpoint file to be loaded into the PQM II.
- ▷ Click **OK**.
- ▷ Select the **File > Edit Settings File Properties** menu item and change the file version of the setpoint file to match the firmware version of the PQM II.
- ▷ With the updated setpoint file selected in the File pane, select the **File > Write Settings to Device** menu item and select the target PQM II to receive the previously saved settings file. A dialog box will appear to confirm the request to download setpoints.
- ▷ Click **Yes** to send the setpoints to the PQM II or **No** to end the process.

The EnerVista PQM II Setup Software will load the setpoint file into the PQM II. If new setpoints were added in the firmware upgrade, they will be set to factory defaults.

# Using the EnerVista PQM II Setup Software

## Entering Setpoints

The System Setup page will be used as an example to illustrate the entering of setpoints.

- ▷ Select the **Setpoint > System Setup** menu item. The following window will appear:

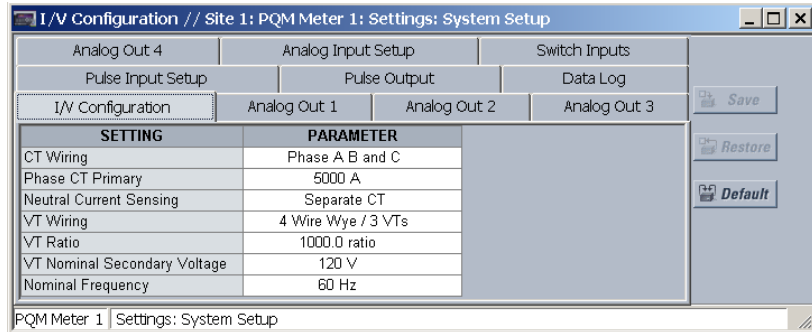

When a non-numeric setpoint such as **CT WIRING** is selected, EnerVista PQM II Setup Software displays a drop-down menu:

SETTING	PARAMETER
CT Wiring	Phase A and C only
Phase CT Primary	Phase A B and C
Neutral Current Sensing	Phase A and B only
VT Wiring	Phase A and C only
VT Ratio	Phase A only

When a numeric setpoint such as **PHASE CT PRIMARY** is selected, EnerVista PQM II Setup Software displays a keypad that allows the user to enter a value within the setpoint range displayed near the top of the keypad:

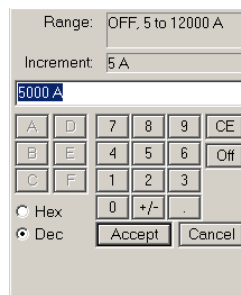

- ▷ Click **Accept** to exit from the keypad and keep the new value. Click on **Cancel** to exit from the keypad and retain the old value.
- ▷ In the Setpoint / System Setup dialog box, click on **Store** to save the values into the PQM II.
- ▷ Click **OK** to accept any changes and exit the window.
- ▷ Click **Cancel** to retain previous values and exit.

## Viewing Actual Values

If a PQM II is connected to a computer via the serial port, any measured value, status and alarm information can be displayed. Use the Actual pull-down menu to select various measured value screens. Monitored values will be displayed and continuously updated.

## Setpoint Files

To print and save all the setpoints to a file follow the steps outlined in : *Saving Setpoints to a File*.

To load an existing setpoints file to a PQM II and/or send the setpoints to the PQM II follow the steps outlined in : *Loading Saved Setpoints*.

## Getting Help

A detailed Help file is included with the EnerVista PQM II Setup Software.

Select the **Help > Contents** menu item to obtain an explanation of any feature, specifications, setpoint, actual value, etc. Context-sensitive help can also be activated by clicking on the desired function.

For easy reference, any topic can be printed by selecting **File > Print Topic** item from the Help file menu bar.

---

# Power Analysis

## Waveform Capture

Two cycles (64 samples/cycle) of voltage and current waveforms can be captured and displayed on a PC using the EnerVista PQM II Setup Software or third party software. Distorted peaks or notches from SCR switching provides clues for taking corrective action. Waveform capture is also a useful tool when investigating possible wiring problems due to its ability to display the phase relationship of the various inputs. The waveform capture feature is implemented into EnerVista PQM II Setup Software as shown below.

Select the **Actual > Power Analysis > Waveform Capture** menu item. The EnerVista PQM II Setup Software will open the Waveform Capture dialog box.

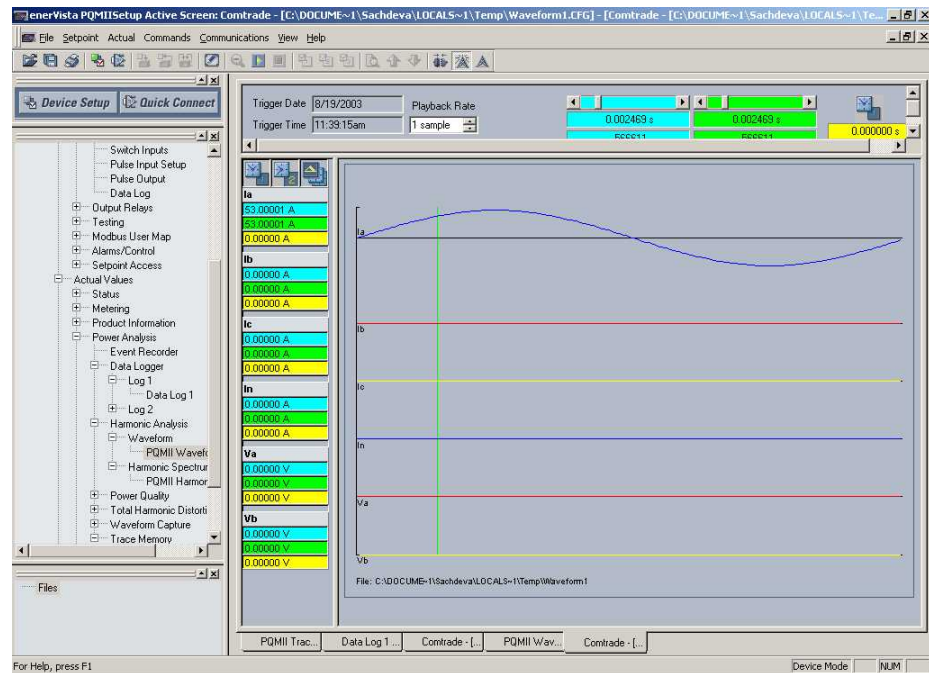

Select the buttons on the left to display the desired waveforms. The waveform values for the current cursor line position are displayed to the right of the selected buttons. Numerical values are displayed directly below the button.

## Harmonic Analysis

Non-linear loads such as variable speed drives, computers, and electronic ballasts can cause harmonics which may lead to problems such as nuisance breaker tripping, telephone interference, transformer, capacitor or motor overheating. For fault diagnosis such as detecting undersized neutral wiring, need for a harmonic rated transformer or effectiveness of harmonic filters; details of the harmonic spectrum are useful and available with the PQM II and the EnerVista PQM II Setup Software.

The EnerVista PQM II Setup Software can perform a harmonic analysis on any of the four current inputs or any of the three voltage inputs by placing the PQM II in a high speed sampling mode (256 samples/cycle) where it will sample one cycle of the user defined parameter. EnerVista PQM II Setup Software then takes this data and performs a FFT (Fast Fourier Transform) to extract the harmonic information. The harmonic analysis feature is implemented into EnerVista PQM II Setup Software as shown below.

- ▷ Select the **Actual > Power Analysis > Harmonic Analysis > Harmonic Spectrum** menu item.  
The EnerVista PQM II Setup Software can display the Harmonic Analysis Spectrum window including the harmonic spectrum up to and including the 62nd harmonic.
- ▷ Enter the trigger parameter for the **Select Trigger** setting.

- ▷ Click the **Select** button for the **Trigger** setting. The Waveform capture window will appear.
- ▷ To display the harmonic spectrum, click the Harmonics button (  ) on the top of the screen.

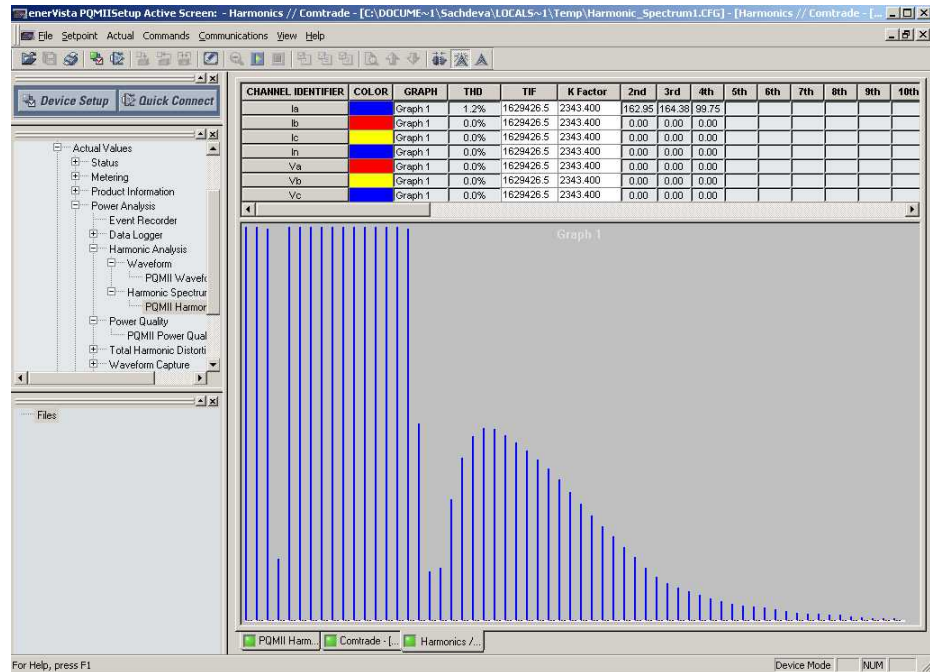

FIGURE 4-3: Harmonic Spectrum Display

The window includes details of the currently selected harmonic and other harmonic analysis-related data (for example, THD, K Factor, etc.).

- ▷ Select **Read Last Trigger From Device** to load previous acquired spectra from the PQM II.

## Trace Memory

The trace memory feature allows the PQM II to be setup to trigger on various conditions. The trace memory can record maximum of 36 cycles of data (16 samples per cycle) for all voltage and current inputs simultaneously. A Total Trace Triggers Counter has been implemented in the PQM II Memory Map at Register 0x0B83. This register will keep a running total of all valid Trace Memory Triggers from the last time power was applied to the PQM II. The Total Trace Triggers counter will rollover to 0 at 65536. The trace memory feature is implemented into the EnerVista PQM II Setup Software as shown below.

- ▷ Select the **Setpoint > PQM II Setup > Trace Memory Setup** menu item to setup the trace memory feature.

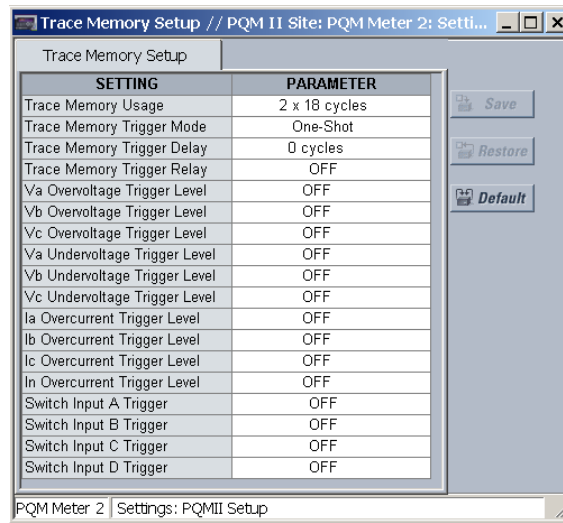

The **Trace Memory Usage** parameter is set as follows:

- 1 x 36 cycles: upon trigger, the entire buffer is filled with 36 cycles of data
- 2 x 18 cycles: 2 separate 18-cycle buffers are created and each is filled upon a trigger
- 3 x 12 cycles: 3 separate 12 cycle buffers are created and each is filled upon a trigger

If the **Trace Memory Trigger Mode** is set to “One-Shot”, then the trace memory is triggered once per buffer; if it is set to “Retrigger”, then it automatically retriggers and overwrites the previous data.

The **Trace Memory Trigger Delay** delays the trigger by the number of cycles specified. The Voltage, Current, and Switch Inputs selections are the parameters and levels that are used to trigger the trace memory. Clicking **Save** sends the current settings to the PQM II.

- ▷ Select the **Actual > Power Analysis > Trace Memory** menu item to view the trace memory data.  
This launches the Trace Memory Waveform window.

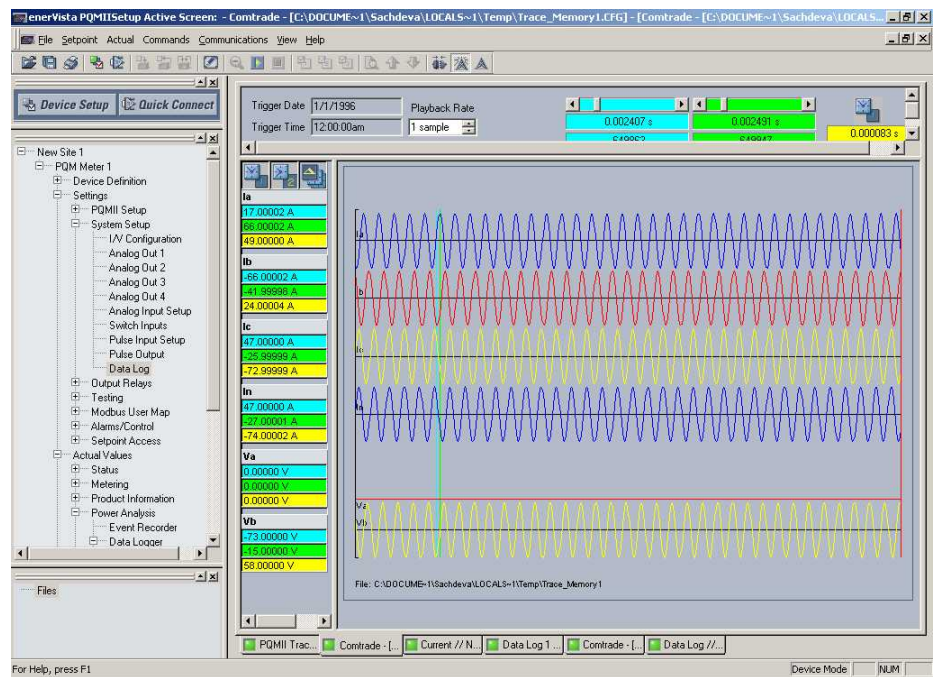

## Data Logger

The data logger feature allows the PQM II to continuously log various specified parameters at the specified rate. The data logger uses the 64 samples/cycle data. This feature is implemented into EnerVista PQM II Setup Software as shown below.

- ▷ Select the **Setpoint > System Setup > Data Log** menu item to setup the data logger feature.  
This launches the Data Log settings box shown below. The state of each data logger and percent filled is shown.
- ▷ Use the **Start Log 1(2)** and **Stop Log 1(2)** buttons to start and stop the logs.

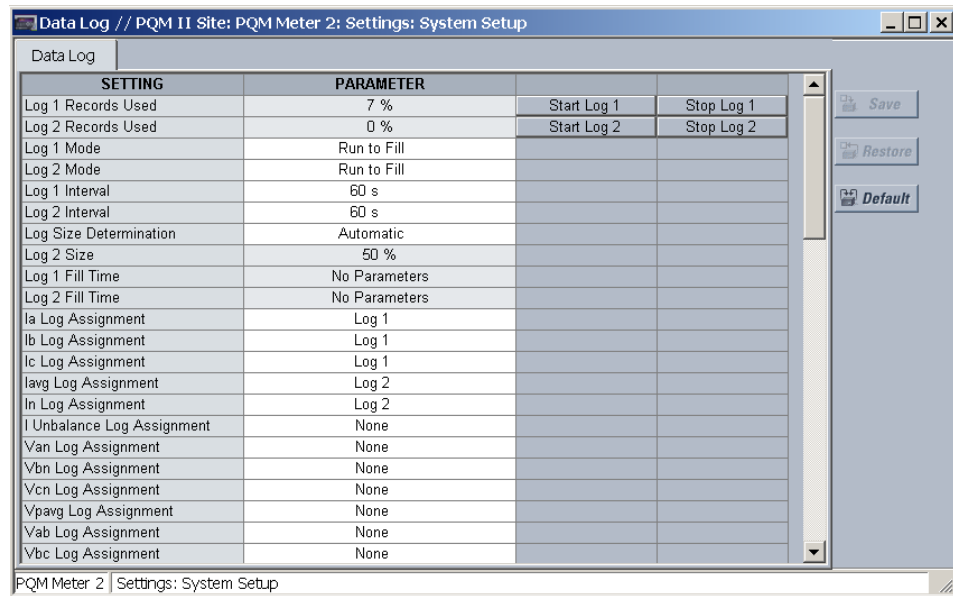

FIGURE 4-4: Data Logger Setup Window

- The **Log 1(2) Mode** parameters are set as follows:
  - “Run to Fill”: when the data logger is full (100%) it will stop logging
  - “Circulate”: when the data logger is full, it will start from the beginning and overwrite the previous data.
- The **Log 1(2) Interval** parameters determine how frequently the PQM II logs each piece of data.
- The total log size is approximately 192KB. The allotment of this memory can be varied between the two logs to maximize the overall log time. Set the **Log Size Determination** to let the PQM II automatically optimize the memory. If desired, the optimization can also be performed manually by the user.
- The **Log 1(2) Fill Time** parameters represent the amount of time the data logger takes to fill to 100%. This time is dependent on the logging interval and the number of parameters being logged.
  - ▷ Set the parameters to be logged by setting the various **Log Assignment** parameters to the desired log.
  - ▷ Select the **Actual > Power Analysis > Data Logger > Log 1 (or Log 2)** item to view the respective data logger.

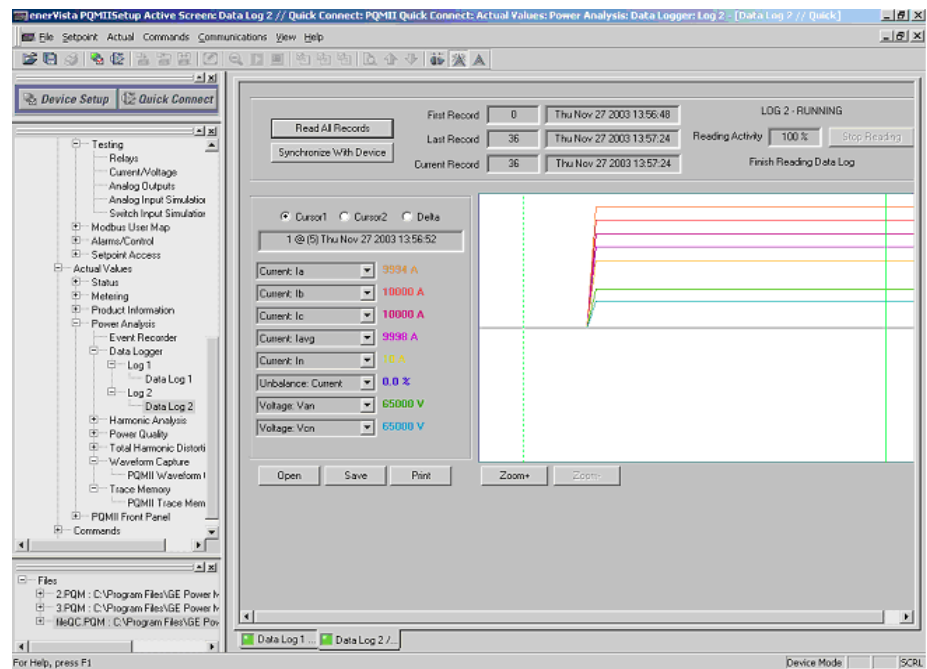

FIGURE 4-5: Data Logger Window

- The Data Log 1(2) dialog box displays the record numbers, data log start time, the current time, and parameter values for the current cursor line position.

## Voltage Disturbance Recorder (VDR)

The Voltage Disturbance Recorder allows the PQM II to monitor and record sag and swell disturbances. This function can record up to 500 sag/swell events for all voltages simultaneously. The events roll-over and old events are lost when more than 500 events are recorded.

**PQM II VDR events are stored in volatile memory. Therefore, all voltage disturbance events will be cleared when control power is cycled to the meter.**

The operation of the voltage disturbance recorder as implemented in the EnerVista PQM II Setup Software is shown below:

- ▶ Select the **Setpoint > System Setup > System Config** menu item.
- ▶ Select the **Voltage Disturbance Recorder Setup** tab.
- ▶ The **Sag Level % Nominal** should be set to the level to which a voltage input must fall before a sag event is to be recorded. The **Swell Level % Nominal** should be set to the level to which a voltage input must rise before a swell event is to be recorded.
- ▶ Click **Save** to send the current settings to the PQM II.

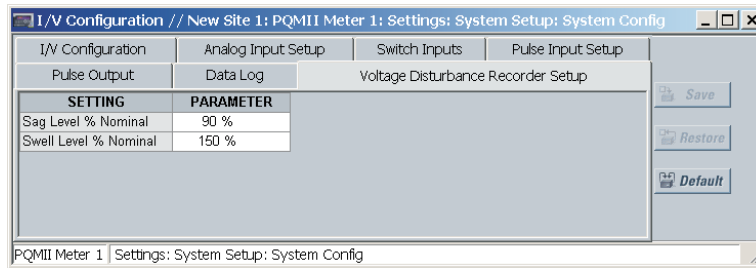

- ▷ Select the **Actual > Power Analysis > Voltage Disturbance Recorder** menu item to view the voltage disturbance recorder events.

Within the voltage disturbance recorder window, each event is listed and can be selected. When the event is selected the following values are displayed:

- **Dist. Number:** The event number. The first event recorded (after the event recorder is cleared) will be given the event number of “1”. Each subsequent event will be given an incrementing event number. If the event number reaches 65535, the event number will rollover back to 1.
- **Dist. Type:** The type refers to the classification of the event (i.e. Sag, Swell, Undervoltage or, Overvoltage)
- **Dist. Source:** The source of the disturbance is the line/phase voltage that the disturbance was measured on.
- **Dist. Time/Date:** The time that the disturbance was recorded. Each disturbance is recorded at the end of the disturbance event.
- **Dist. Dur.:** The duration of the event in cycles.
- **Dist. Average Voltage:** The average RMS voltage recorded during the disturbance.

The **Clear Events** button clears the voltage disturbance recorder. Events are overwritten when the event recorder reaches 500 events.

The **Save** button exports the events to a CSV format file. A text file viewer can open and read the file.

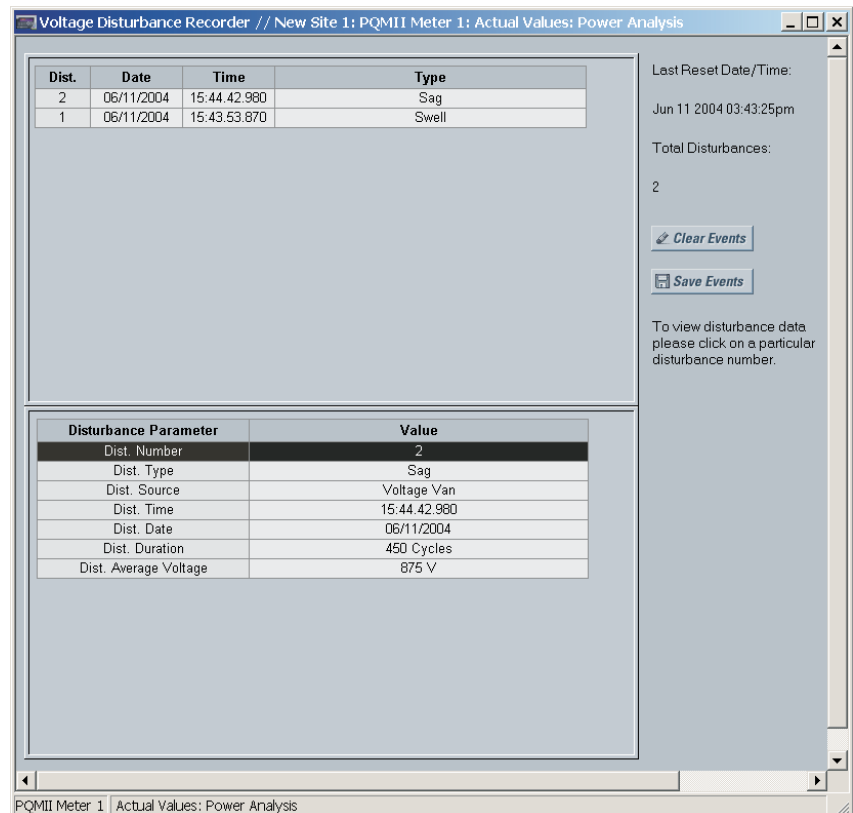

FIGURE 4-6: Voltage Disturbance Recorder

## Using EnerVista Viewpoint Monitor with the PQM II

### Plug and Play Example

GE Vernova's EnerVista Viewpoint Monitoring is an easy to setup and use, optional workstation based, HMI software solution that automatically collects and centralizes data from GE Vernova devices including relays and the PQM II for visualization, monitoring and analysis.

EnerVista Viewpoint Monitoring uses connection based setup via serial, ethernet or modem and automatically generates a detailed device overview and in particular for the PQM II, metering, power, demand, energy and analysis screens.

A demo version of EnerVista Viewpoint Monitoring is available allowing customers to connect to devices and experience visualization, monitoring and analysis of their system. More information and the installation package can be found at: <https://www.gevernova.com/grid-solutions/automation/substation-solutions/software-tools/enervista-viewpoint-monitoring>

There is also added functionality of EnerVista Viewpoint Monitoring ViewNodes that will extend monitoring functionality to other remote workstations helping with added operator awareness and assisting in increase system reliability.

- ▷ Ensure that the PQM II device has been configured using EnerVista PQM II Setup Software and communications functionality is verified
- ▷ Download the EnerVista Viewpoint Monitoring installation software from the GE Vernova website and run the installation
- ▷ Launch the EnerVista Viewpoint Monitoring Software

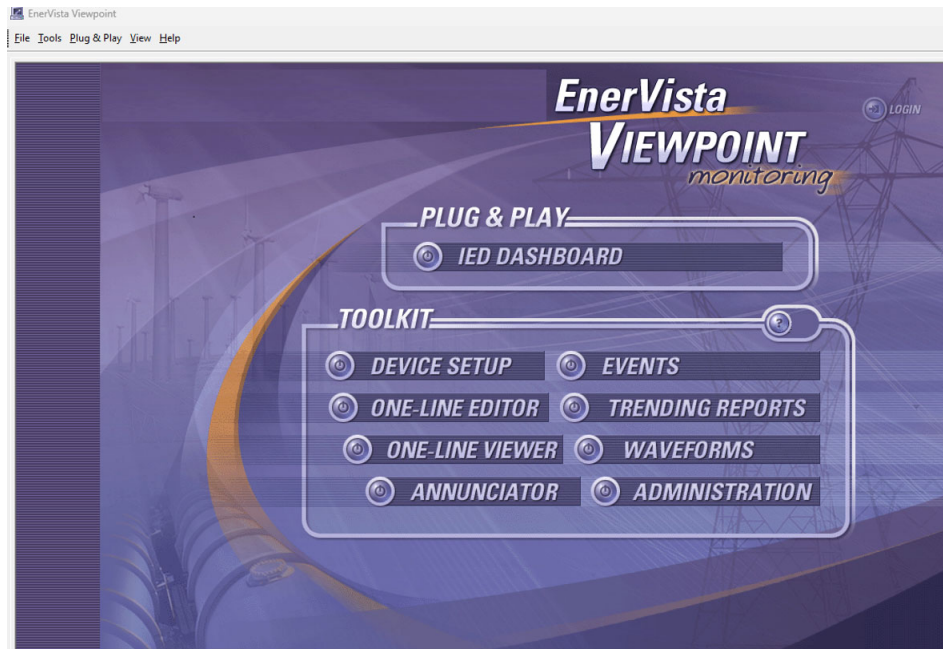

FIGURE 4-7: EnerVista Viewpoint Monitoring Main Window

- ▷ Click the **Device Setup** button to open the Device Setup window.
- ▷ Click the **Add Site** button to define a new site.
- ▷ Enter the desired site name in the **Site Name** field.  
If desired, a short description of site can also be entered along with the display order of devices defined for the site.
- ▷ Click the **OK** button when complete.  
The new site will appear in the upper-left list in the EnerVista PQM II Setup Software window.
- ▷ Click the **Add Device** button to define the new device.
- ▷ Enter the desired name in the **Device Name** field and a description (optional) of the site.
- ▷ Select the appropriate communications interface (Ethernet or Serial) and fill in the required information for the PQM II.

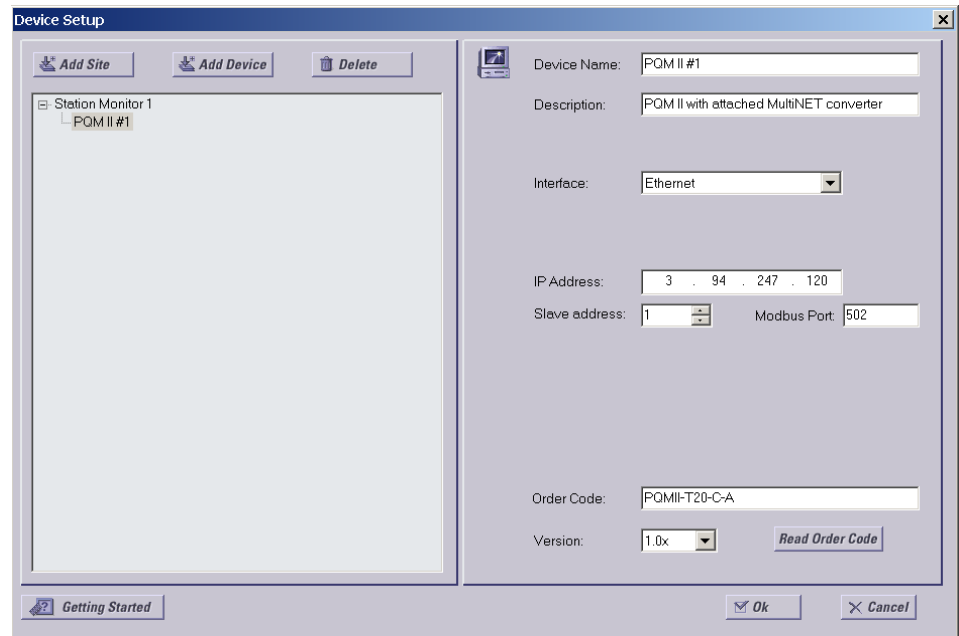

FIGURE 4–8: Device Setup Screen (Example)

- ▷ Click the **Read Order Code** button to connect to the PQM II device and upload the order code.  
If a communications error occurs, ensure that communications values entered in the previous step correspond to the relay setting values.
- ▷ Click **OK** when complete.
- ▷ From the EnerVista main window, select the **IED Dashboard** item to open the Plug and Play IED dashboard.  
An icon for the PQM II will be shown.

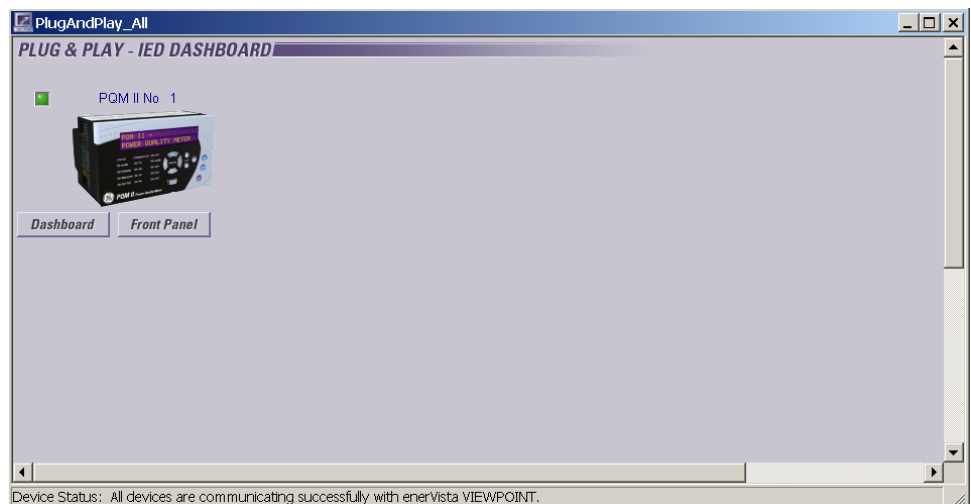

FIGURE 4–9: 'Plug and Play' Dashboard

- ▷ Click the **Dashboard** button below the PQM II icon to view the device information.  
We have now successfully accessed our PQM II through EnerVista Viewpoint Monitor.

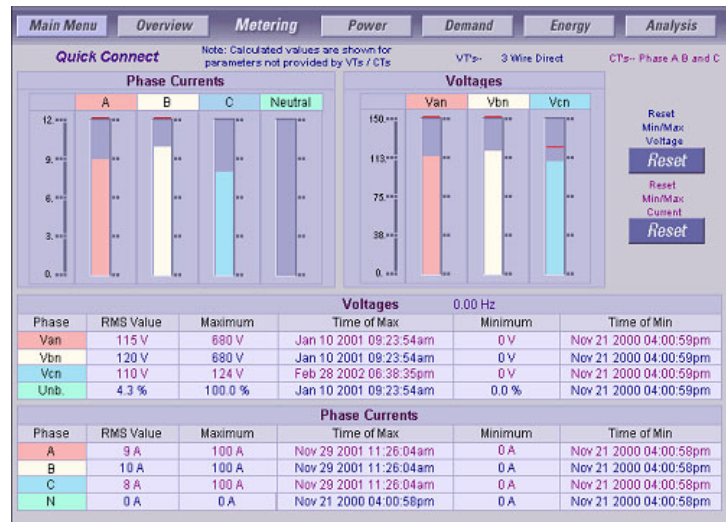
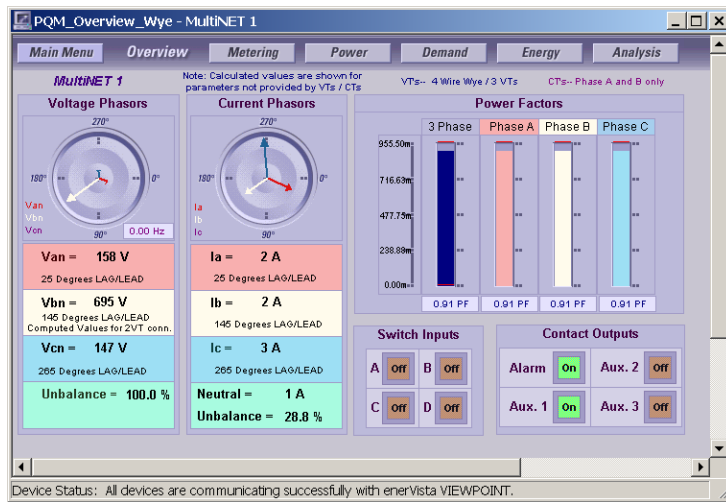

FIGURE 4-10: EnerVista Plug and Play Screens



# PQM II Power Quality Meter

## Chapter 5: Setpoints

---

### Introduction

#### Setpoint Entry Methods

Prior to operating the PQM II, it is necessary to program setpoints to define system characteristics and alarm settings by one of the following methods:

- Front panel, using the keys and display.
- Rear terminal RS485 port COM1 or COM2, or front RS232 port and a computer running the EnerVista PQM Setup Software included with the PQM II, or from a SCADA system running user-defined software.



















Either of the above methods can be used to enter the same information. However, a computer makes information entry considerably easier. Moreover, a computer allows setpoint files to be stored and downloaded for fast, error-free entry. The EnerVista PQM Setup Software included with the PQM II facilitates this process. With this software, setpoints can be modified remotely and downloaded at a later time to the PQM II. Refer to : *Using the EnerVista PQM II Setup Software* for additional details.























Setpoint messages are organized into logical groups or pages for easy reference. Messages may vary somewhat from those illustrated because of installed options, and messages associated with disabled features will be hidden. This context sensitive operation eliminates confusing detail. Before accurate monitoring can begin, the setpoints on each page should be worked through, entering values either by local keypad or computer.

















The PQM II leaves the factory with setpoints programmed to default values. These values are shown in all setpoint message illustrations. Many of these factory default values can be left unchanged. At a minimum, however, setpoints that are shown shaded in : *Current and Voltage Configuration* must be entered for the system to

function correctly. As a safeguard, the PQM II will alarm and lock-out until values have been entered for these setpoints. The **CRITICAL SETPOINTS NOT STORED** alarm message will be displayed until the PQM II is programmed with these critical setpoints.

### Setpoints Main Menu

<div style="border: 1px solid black; padding: 2px;">                 ■ SETPOINTS [▷]                  S1 PQM II SETUP             </div>		<div style="border: 1px solid black; padding: 2px;">                 ■ PREFERENCES [▷]             </div>	See page 5-5.
MESSAGE		<div style="border: 1px solid black; padding: 2px;">                 ■ SETPOINT ACCESS [▷]             </div>	See page 5-5.
MESSAGE		<div style="border: 1px solid black; padding: 2px;">                 ■ COM1 RS485 SERIAL PORT [▷]             </div>	See page 5-7.
MESSAGE		<div style="border: 1px solid black; padding: 2px;">                 ■ COM2 RS485 SERIAL PORT [▷]             </div>	See page 5-7.
MESSAGE		<div style="border: 1px solid black; padding: 2px;">                 ■ FRONT PANEL RS232 SERIAL PORT [▷]             </div>	See page 5-7.
MESSAGE		<div style="border: 1px solid black; padding: 2px;">                 ■ DNP 3.0 CONFIGURATION [▷]             </div>	See page 5-8.
MESSAGE		<div style="border: 1px solid black; padding: 2px;">                 ■ CLOCK [▷]             </div>	See page 5-8.
MESSAGE		<div style="border: 1px solid black; padding: 2px;">                 ■ CALCULATION PARAMETERS [▷]             </div>	See page 5-10.
MESSAGE		<div style="border: 1px solid black; padding: 2px;">                 ■ CLEAR DATA [▷]             </div>	See page 5-12.
MESSAGE		<div style="border: 1px solid black; padding: 2px;">                 ■ EVENT RECORDER [▷]             </div>	See page 5-13.
MESSAGE		<div style="border: 1px solid black; padding: 2px;">                 ■ TRACE MEMORY [▷]             </div>	See page 5-14.
MESSAGE		<div style="border: 1px solid black; padding: 2px;">                 ■ PROGRAMMABLE MESSAGE [▷]             </div>	See page 5-17.
MESSAGE		<div style="border: 1px solid black; padding: 2px;">                 ■ PRODUCT OPTIONS [▷]             </div>	See page 5-18.
MESSAGE		<div style="border: 1px solid black; padding: 2px;">                 ■ END OF PAGE S1 [▷]             </div>	
MESSAGE			
<div style="border: 1px solid black; padding: 2px;">                 ■ SETPOINTS [▷]                  S2 SYSTEM SETUP             </div>		<div style="border: 1px solid black; padding: 2px;">                 ■ CURRENT/ VOLTAGE CONFIG. [▷]             </div>	See page 5-18.
MESSAGE		<div style="border: 1px solid black; padding: 2px;">                 ■ ANALOG OUTPUT 1 [▷]             </div>	See page 5-21.
MESSAGE		<div style="border: 1px solid black; padding: 2px;">                 ■ ANALOG OUTPUT 2 [▷]             </div>	See page 5-21.

MESSAGE		■ ANALOG OUTPUT 3 [▷]	See page 5-21.
MESSAGE		■ ANALOG OUTPUT 4 [▷]	See page 5-21.
MESSAGE		■ ANALOG INPUT [▷]	See page 5-25.
MESSAGE		■ SWITCH INPUT A [▷]	See page 5-27.
MESSAGE		■ SWITCH INPUT B [▷]	See page 5-27.
MESSAGE		■ SWITCH INPUT C [▷]	See page 5-27.
MESSAGE		■ SWITCH INPUT D [▷]	See page 5-27.
MESSAGE		■ PULSE OUTPUT [▷]	See page 5-28.
MESSAGE		■ PULSE INPUT [▷]	See page 5-29.
MESSAGE		■ DATA LOGGER [▷]	See page 5-30.
MESSAGE		■ VOLTAGE DIST. RECORDER [▷]	See page 5-30.
MESSAGE		■ END OF PAGE S2 [▷]	
MESSAGE			
		■ SETPOINTS S3 OUTPUT RELAYS [▷]	
		■ ALARM RELAY [▷]	See page 5-31.
MESSAGE		■ AUXILIARY RELAY 1 [▷]	See page 5-31.
MESSAGE		■ AUXILIARY RELAY 2 [▷]	See page 5-31.
MESSAGE		■ AUXILIARY RELAY 3 [▷]	See page 5-31.
MESSAGE		■ END OF PAGE S3 [▷]	
MESSAGE			
		■ SETPOINTS S4 ALARMS/CONTROL [▷]	
		■ CURRENT/VOLTAGE [▷]	See page 5-32.
MESSAGE		■ TOTAL HARMONIC DISTORTION [▷]	See page 5-37.

MESSAGE		■ FREQUENCY [▷]	See page 5-38.
MESSAGE		■ POWER [▷]	See page 5-39.
MESSAGE		■ POWER FACTOR [▷]	See page 5-41.
MESSAGE		■ DEMAND [▷]	See page 5-44.
MESSAGE		■ PULSE INPUT [▷]	See page 5-46.
MESSAGE		■ TIME [▷]	See page 5-47.
MESSAGE		■ MISCELLANEOUS [▷]	See page 5-48.
MESSAGE		■ END OF PAGE S4 [▷]	
MESSAGE		■ SETPOINTS S5 TESTING [▷]	
		■ TEST RELAYS & LEDS [▷]	See page 5-49.
MESSAGE		■ CURRENT/ VOLTAGE SIMULATION [▷]	See page 5-49.
MESSAGE		■ ANALOG OUTPUTS SIMULATION [▷]	See page 5-50.
MESSAGE		■ ANALOG INPUT SIMULATION [▷]	See page 5-51.
MESSAGE		■ SWITCH INPUTS SIMULATION [▷]	See page 5-51.
MESSAGE		■ FACTORY USE ONLY [▷]	See page 5-52.
MESSAGE		■ END OF PAGE S5 [▷]	

## S1 PQM II Setup

### Description

General settings to configure the PQM II are entered on this page. This includes user preferences, the RS485 and RS232 communication ports, loading of factory defaults, and user-programmable messages.

## Preferences

PATH: SETPOINTS ⇨ S1 PQM II SETUP ⇨ PREFERENCES

<div style="border: 1px solid black; padding: 2px;"> <span style="background-color: black; color: white; padding: 2px;">■ PREFERENCES</span> [▷]             </div>		<b>DEFAULT MESSAGE TIME:</b> 1.0 MINUTES	<i>Range: 0.1 to 120.0 minutes in steps of 0.1 or OFF</i>
	MESSAGE	<b>DISPLAY FILTER CONSTANT:</b> 4	<i>Range: 1 to 10 in steps of 1</i>

- DEFAULT MESSAGE TIME:** Up to 10 default messages can be selected to scan sequentially when the PQM II is left unattended. If no keys are pressed for the interval defined by the **DEFAULT MESSAGE TIME** setting, then the currently displayed message is automatically overwritten by the first default message. After 3 seconds, the next default message in the sequence is displayed. Alarm messages will always override the default message display. Note that any setpoint or measured value can be selected as a default message.  
*See : Default Messages for details on default message operation and programming.*
- DISPLAY FILTER CONSTANT:** Display filtering may be required in applications where large fluctuations in current and/or voltage are normally present. This setpoint allows the user to enter the PQM II filter constant to average all metered values. If the **DISPLAY FILTER CONSTANT** setpoint is set to 1, the PQM II updates the displayed metered values approximately every 400 ms. Therefore, the display updating equals **DISPLAY FILTER CONSTANT** × 400 ms.

## Setpoint Access

PATH: SETPOINTS ⇨ S1 PQM II SETUP ⇨ SETPOINT ACCESS

<div style="border: 1px solid black; padding: 2px;"> <span style="background-color: black; color: white; padding: 2px;">■ SETPOINT ACCESS</span> [▷]             </div>		<b>SETPOINT ACCESS:</b> DISABLE	<i>Range: Disable, Enable</i>
	MESSAGE	<b>ENTER SETPOINT ACCESS CODE:</b> 1	<i>Range: 1 to 999 in steps of 1</i>
	MESSAGE	<b>SETPOINT ACCESS ON FOR:</b> 5 min.	<i>Range: 1 to 300 min. in steps of 1 or Unlimited</i>
	MESSAGE	<b>CHANGE SETPOINT ACCESS CODE:</b> No	<i>Range: No, Yes</i>
	MESSAGE	<b>ENTER NEW ACCESS CODE:</b> 0	<i>Range: 1 to 999 in steps of 1</i>
	MESSAGE	<b>RE-ENTER NEW ACCESS CODE:</b> 0	<i>Range: 1 to 999 in steps of 1</i>
	MESSAGE	<b>ENCRYPTED SETPOINT ACCESS CODE:</b> 376	<i>Range: N/A</i>

To enable setpoint access, follow the steps outlined in the following diagram:

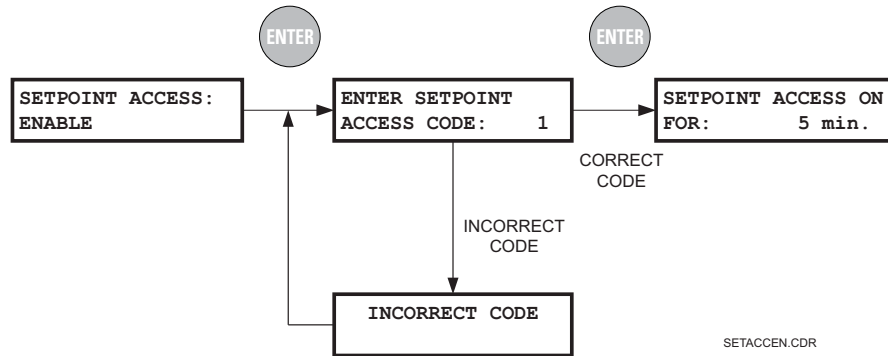

The factory default access code for the PQM II is 1.

If three attempts are made to enable setpoint access with an incorrect code, the value of the setpoint access setpoint changes to “Disabled” and the above procedure must be repeated.

Once setpoint access is enabled, the Program LED indicator turns on. Setpoint alterations are allowed as long as the Program LED indicator remains on. Setpoint access is disabled and the Program LED indicator turns off when:

- The time programmed in **S1 PQM II SETUP** ⇒ **SETPOINT ACCESS** ⇒ **SETPOINT ACCESS ON FOR** is reached
- The control power to the PQM II is removed
- The factory setpoints are reloaded

To permanently enable the setpoint access feature, enable setpoint access and then set **SETPOINT ACCESS ON FOR** to “Unlimited”. Setpoint access remains enabled even if the control power is removed from the PQM II.

**Setpoints can be changed via the serial ports regardless of the state of the setpoint access feature or the state of an input switch assigned to setpoint access.**

To change the setpoint access code, enable setpoint access and perform the steps as outlined below:

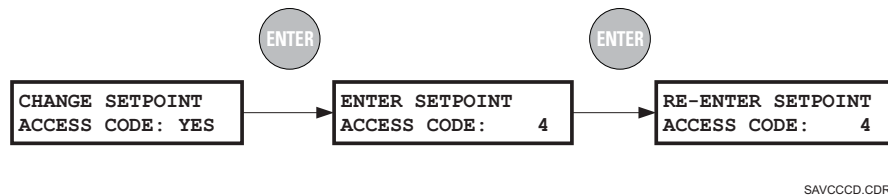

If an attempt is made to change a setpoint when setpoint access is disabled, the **SETPOINT ACCESS: DISABLED** message is displayed to allow setpoint access to be enabled. Once setpoint access has been enabled, the PQM II display will return to the original setpoint message.

If the control option is installed and one of the switches is assigned to “Setpoint Access”, the setpoint access switch and the software setpoint access will act as a logical ‘AND’. That is, both conditions must be satisfied before setpoint access will be

enabled. Assuming the setpoint access switch activation is set to closed, the following flash messages will appear depending upon the condition present when the ENTER key is pressed.

**Table 1: Setpoint Access Conditions**

Condition		Displayed Message
Access Code	Switch Input	
Incorrect	Open	<b>SETPOINT ACCESS OFF ENTER ACCESS CODE</b>
Incorrect	Closed	<b>SETPOINT ACCESS OFF ENTER ACCESS CODE</b>
Correct	Open	<b>CANNOT ALTER SETTING ACCESS SW. DISABLED</b>
Correct	Closed	<b>NEW SETPOINT STORED</b>

## Serial Ports

PATH: SETPOINTS ⇌ S1 PQM II SETUP ⇌ ⬇️ COM1 RS485 SERIAL PORT

<div style="display: flex; justify-content: space-between; align-items: center;"> <span>■ COM1 RS485 SERIAL PORT</span> <span>[▷]</span> </div>		<b>MODBUS COMMUNICATION ADDRESS: 1</b>	<i>Range: 1 to 255 in steps of 1</i>
MESSAGE		<b>COM1 BAUD RATE: 19200 BAUD</b>	<i>Range: 1200, 2400, 4800, 9600, and 19200 baud</i>
MESSAGE		<b>COM1 PARITY: NONE</b>	<i>Range: None, Even, Odd</i>
<div style="display: flex; justify-content: space-between; align-items: center;"> <span>■ COM2 RS485 SERIAL PORT</span> <span>[▷]</span> </div>		<b>COM2 BAUD RATE: 19200 BAUD</b>	<i>Range: 1200, 2400, 4800, 9600, and 19200 baud</i>
MESSAGE		<b>COM2 PARITY: NONE</b>	<i>Range: None, Even, Odd</i>
<div style="display: flex; justify-content: space-between; align-items: center;"> <span>■ FRONT PANEL RS232 SERIAL PORT</span> <span>[▷]</span> </div>		<b>RS232 BAUD RATE: 9600 Baud</b>	<i>Range: 1200, 2400, 4800, 9600, and 19200 baud</i>
MESSAGE		<b>RS232 PARITY: None</b>	<i>Range: None, Even, Odd</i>

- MODBUS COMMUNICATION ADDRESS:** Enter a unique address from 1 to 255. The selected address is used for all serial communication ports. Address 0 represents a broadcast message to which all PQM IIs will listen but not respond. Although addresses do not have to be sequential, no two PQM IIs can have the same address or there will be conflicts resulting in errors. Generally, each PQM II added to the link uses the next higher address, starting from address 1.
- BAUD RATE:** Enter the baud rate for each port: 1200, 2400, 4800, 9600, or 19200 baud. All PQM IIs and the computer on the RS485 communication link must run at the same baud rate. The fastest response is obtained at 19200 baud. Use slower baud rates if noise becomes a problem. The data frame consists of 1 start bit, 8 data bits, 1 stop bit and a programmable parity bit. The baud rate default setting is 9600.

- **PARITY:** Enter the parity for each communication port: “Even”, “Odd”, or “None”. All PQM IIs on the RS485 communication link and the computer connecting them must have the same parity.

## DNP 3.0 Configuration

PATH: SETPOINTS ⇒ S1 PQM II SETUP ⇒ DNP 3.0 CONFIGURATION

<div style="border: 1px solid black; padding: 5px;"> <p>■ DNP 3.0 CONFIGURATION [▷]</p> </div>		<p>DNP PORT: None</p>	Range:None, COM1, COM2
		<p>DNP SLAVE ADDRESS: 0</p>	Range:0 to 255 in steps of 1
		<p>DNP TURNAROUND TIME: 0 ms</p>	Range:0 to 100 ms in steps of 10

- **DNP PORT:** Select the appropriate PQM II port to be used for DNP protocol. The COM2 selection is only available if T1 or T20 option is installed in the PQM II. Each port is configured as shown in : *Serial Ports*.
- **DNP SLAVE ADDRESS:** Enter a unique address from 0 to 255 for this particular PQM II. The address selected is applied to the PQM II port currently assigned to communicate using the DNP protocol. Although addresses do not have to be sequential, no two PQM IIs that are daisy chained together can have the same address or there will be conflicts resulting in errors. Generally each PQM II added to the link will use the next higher address.
- **DNP TURNAROUND TIME:** The turnaround time is useful in applications where the RS485 converter without RTS or DTR switching is being employed. A typical value for the delay is 30 ms to allow the transmitter to drop in the RS485 converter.

## Clock

PATH: SETPOINTS ⇒ S1 PQM II SETUP ⇒ CLOCK

<div style="border: 1px solid black; padding: 5px;"> <p>■ CLOCK [▷]</p> </div>		<p>SET TIME hh:mm:ss 12:00:00 am DATE ▷</p>	Range:time format as shown
	<p>MESSAGE </p>	<p>SET DATE dd:mm:yyyy Nov 21, 2003</p>	Range:date format as shown

- **SET TIME/DATE:** These messages are used to set the time and date for the PQM II software clock.  
The PQM II software clock is retained for power interruptions of approximately thirty days. A Clock Not Set alarm can be enabled so that an alarm will occur on the loss of clock data. The time and date are used for all time-stamped data. If the clock has not been set, a “?” will appear on the right-hand side of the displayed time for all time-stamped data. Follow the steps shown below to set the new time and date.

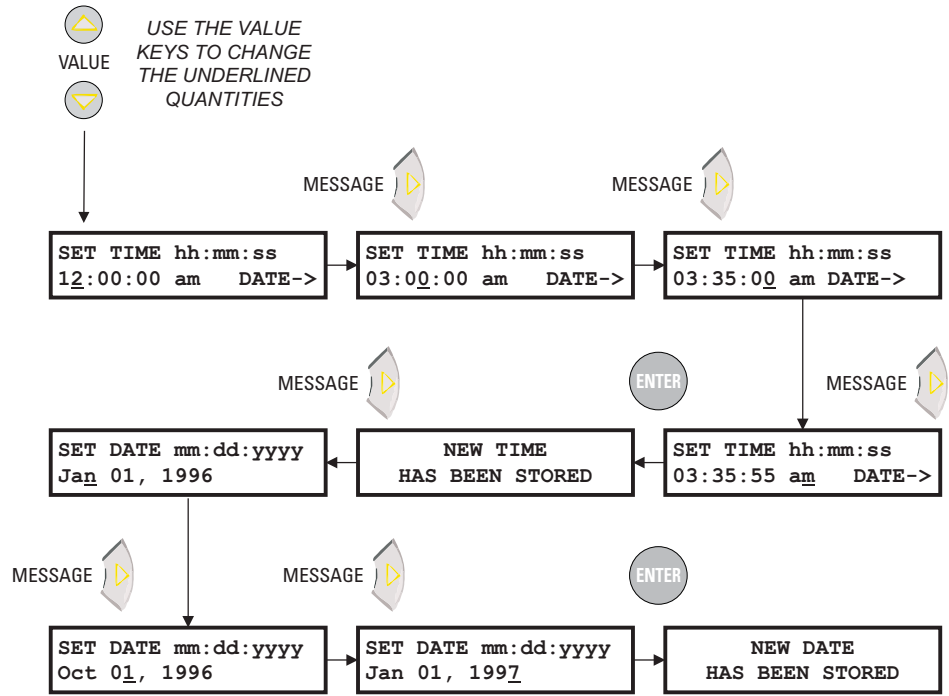

FIGURE 5-1: Setting the Date and Time

The time and date can also be set via Modbus communications.

## Calculation Parameters

PATH: SETPOINTS ⇨ S1 PQM II SETUP ⇨ CALCULATION PARAMETERS

■ CALCULATION PARAMETERS	[▷]		<b>EXTRACT FUNDAMENTAL:</b> DISABLE	Range: Disable, Enable
	MESSAGE		<b>CURRENT DEMAND TYPE:</b> THERMAL EXPONENTIAL	Range: Thermal Exponential, Rolling Interval, Block Interval
	MESSAGE		<b>CURRENT DEMAND TIME INTERVAL:</b> 30 min.	Range: 5 to 180 min. in steps of 1
	MESSAGE		<b>POWER DEMAND TYPE:</b> THERMAL EXPONENTIAL	Range: Thermal Exponential, Rolling Interval, Block Interval
	MESSAGE		<b>POWER DEMAND TIME INTERVAL:</b> 30 min.	Range: 5 to 180 min. in steps of 1
	MESSAGE		<b>ENERGY COST PER kWh</b> 10.00 cents	Range: 0.01 to 500.00 cents in steps of 0.01
	MESSAGE		<b>TARIFF PERIOD 1</b> START TIME: 0 min.	Range: 0 to 1439 min. in steps of 1
	MESSAGE		<b>TARIFF PERIOD 1 COST</b> PER kWh: 10.00 cents	Range: 0.01 to 500.00 cents in steps of 0.01
	MESSAGE		<b>TARIFF PERIOD 2</b> START TIME: 0 min.	Range: 0 to 1439 min. in steps of 1
	MESSAGE		<b>TARIFF PERIOD 2 COST</b> PER kWh: 10.00 cents	Range: 0.01 to 500.00 cents in steps of 0.01
	MESSAGE		<b>TARIFF PERIOD 3</b> START TIME: 0 min.	Range: 0 to 1439 min. in steps of 1
	MESSAGE		<b>TARIFF PERIOD 3 COST</b> PER kWh: 10.00 cents	Range: 0.01 to 500.00 cents in steps of 0.01

The PQM II can be programmed to calculate metering quantities and demand by various methods.

- **EXTRACT FUNDAMENTAL:** The PQM II can be programmed to calculate all metering quantities using true RMS values or the fundamental component of the sampled data. When this setpoint is set to “Disable”, the PQM II will include all harmonic content, up to the 32nd harmonic, when making metering calculations. When this setpoint is set to “Enable”, the PQM II will extract the fundamental contribution of the sampled data only and use this contribution to calculate all metering quantities. Many utilities base their metering upon fundamental, or displacement, values. Using the fundamental contribution allows one to compare the quantities measured by the PQM II with the local utility meter.
- **CURRENT DEMAND TYPE:** Three current demand calculation methods are available: thermal exponential, block interval, and rolling interval (see the Demand Calculation Methods table below). The current demand for each phase and neutral is calculated individually.
- **CURRENT DEMAND TIME INTERVAL:** Enter the time period over which the current demand calculation is to be performed.
- **POWER DEMAND TYPE:** Three real/reactive/apparent power demand calculation methods are available: thermal exponential, block interval, and rolling

interval (see the Demand Calculation Methods table below). The three phase real/ reactive/apparent power demand is calculated.

- **POWER DEMAND TIME INTERVAL:** Enter the time period over which the power demand calculation is to be performed.



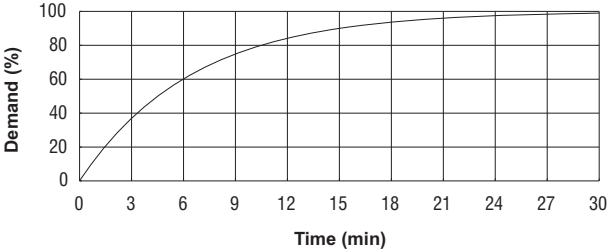









**Table 2: Demand Calculation Methods**

Method	Description
Thermal Exponential	<p>This selection emulates the action of an analog peak-recording thermal demand meter. The PQM II measures the average quantity (RMS current, real power, reactive power, or apparent power) on each phase every minute and assumes the circuit quantity remains at this value until updated by the next measurement. It calculates the “thermal demand equivalent” based on the following equation:</p> $d(t) = D(1 - e^{-kt}) \tag{EQ 5.1}$ <p>where: <math>d</math> = demand after applying input quantity for time <math>t</math> (in min.)  <math>D</math> = input quantity (constant)  <math>k = 2.3 /</math> thermal 90% response time</p>  <p>The graph above shows the thermal response characteristic for a thermal 90% response time of 15 minutes. A setpoint establishes the time to reach 90% of a steady-state value, just as the response time of an analog instrument (a steady-state value applied for twice the response time will indicate 99% of the value).</p>
Block Interval	<p>This selection calculates a linear average of the quantity (RMS current, real power, reactive power, or apparent power) over the programmed demand <b>TIME INTERVAL</b>. Each new value of demand becomes available at the end of each time interval.</p>
Rolling Interval	<p>This selection calculates a linear average of the quantity (RMS current, real power, reactive power, or apparent power) over the programmed demand <b>TIME INTERVAL</b> (in the same way as Block Interval). The value is updated every minute and indicates the demand over the time interval just preceding the time of update.</p>

- **ENERGY COST PER kWh:** Enter the cost per kWh that is charged by the local utility.
- **TARIFF PERIOD START TIME:** Enter the start time for each of the three tariff period calculations.
- **TARIFF PERIOD COST PER kWh:** Enter the cost per kWh for each of the three tariff periods.

## Clear Data

PATH: SETPOINTS ⇨ S1 PQM II SETUP ⇨ CLEAR DATA

■ CLEAR DATA	[▷]		CLEAR ENERGY VALUES: NO	Range:Yes, No
	MESSAGE		CLEAR MAX DEMAND VALUES: NO	Range:Yes, No
	MESSAGE		CLEAR ALL DEMAND VALUES: NO	Range:Yes, No
	MESSAGE		CLEAR MIN/MAX CURRENT VALUES: NO	Range:Yes, No
	MESSAGE		CLEAR MIN/MAX VOLTAGE VALUES: NO	Range:Yes, No
	MESSAGE		CLEAR MIN/MAX POWER VALUES: NO	Range:Yes, No
	MESSAGE		CLEAR MIN/MAX FREQUENCY VALUES: NO	Range:Yes, No
	MESSAGE		CLEAR MAX THD VALUES: NO	Range:Yes, No
	MESSAGE		CLEAR PULSE INPUT VALUES: NO	Range:Yes, No
	MESSAGE		CLEAR EVENT RECORD: NO	Range:Yes, No
	MESSAGE		CLEAR VOLTAGE DIST. RECORD: NO	Range:Yes, No
	MESSAGE		LOAD FACTORY DEFAULT SETPOINTS: NO	Range:Yes, No

- **CLEAR ENERGY VALUES:** Enter “Yes” to clear all the energy used data in the **A1 METERING** ⇨ **ENERGY** actual values subgroup. The **TIME OF LAST RESET** date under the same subgroup is updated upon issuing this command.
- **CLEAR MAX DEMAND VALUES:** Enter “Yes” to clear all the maximum power and current demand data under the actual values subgroup **A1 METERING** ⇨ **DEMAND**. The time and date associated with each message will be updated to the current date upon issuing this command.
- **CLEAR ALL DEMAND VALUES:** Enter “Yes” to clear all the power and current demand data under the actual values subgroup **A1 METERING** ⇨ **DEMAND**. The time and date associated with each message will be updated to the current date upon issuing this command.
- **CLEAR MIN/MAX CURRENT VALUES:** Enter “Yes” to clear all the minimum/maximum current data under the actual values subgroup **A1 METERING** ⇨ **CURRENT**. The time and date associated with each message will be updated to the current date upon issuing this command.
- **CLEAR MIN/MAX VOLTAGE VALUES:** Enter “Yes” to clear all the minimum/maximum voltage data under the actual values subgroup **A1 METERING** ⇨ **VOLTAGE**. The time and date associated with each message will be updated to the current date upon issuing this command.

- **CLEAR MIN/MAX POWER VALUES:** Enter “Yes” to clear all the minimum/maximum power data under the actual values subgroup **A1 METERING** ⇨ ⇩ **POWER**. The time and date associated with each message will be updated to the current date upon issuing this command.
- **CLEAR MIN/MAX FREQUENCY VALUES:** Enter “Yes” to clear all the minimum/maximum frequency data under the actual values subgroup **A1 METERING** ⇨ ⇩ **FREQUENCY**. The time and date associated with each message will be updated to the current date upon issuing this command.
- **CLEAR MAX THD VALUES:** Enter “Yes” to clear all the max THD data under the actual values subgroup **A3 POWER ANALYSIS** ⇨ ⇩ **TOTAL HARMONIC DISTORTION**. The time and date associated with each message will be updated to the current date upon issuing this command.
- **CLEAR PULSE INPUT VALUES:** Enter “Yes” to clear all the pulse input values under the actual values subgroup **A1 METERING** ⇨ ⇩ **PULSE INPUT**. The time and date associated with this message will be updated to the current date upon issuing this command.
- **CLEAR EVENT RECORD:** Enter “Yes” to clear all of the events in the Event Record. This will eliminate all previous events from the Event Record and create a Clear Events event as the new event number 1. The Event Recorder can be cleared only if it is enabled in **S1 PQM II SETUP** ⇨ ⇩ **EVENT RECORDER** ⇨ ⇩ **EVENT RECORDER OPERATION**.

The **CLEAR EVENT RECORD** command takes six seconds to complete, during which no new events will be logged. Do not cycle power to the unit while the event record is being cleared.

- **CLEAR VOLTAGE DIST. RECORD:** Enter “Yes” to clear all of the events in the Voltage Disturbance Record.
- **LOAD FACTORY DEFAULT SETPOINTS:** When the PQM II is shipped from the factory all setpoints will be set to factory default values. These settings are shown in the setpoint message reference figures. To return a PQM II to these known setpoints select “Yes” and press the key while this message is displayed. The display will then warn that all setpoints will be lost and will ask whether to continue. Select yes again to reload the setpoints. It is a good idea to first load factory defaults when replacing a PQM II to ensure all the settings are defaulted to reasonable values.

## Event Recorder



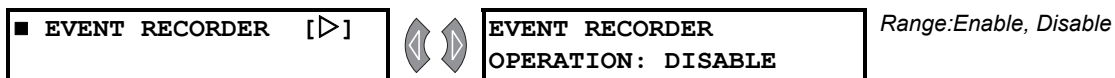































PATH: SETPOINTS ⇨ S1 PQM II SETUP ⇨ ⇩ EVENT RECORDER



The Event Recorder can be disabled or enabled using the **EVENT RECORDER OPERATION** setpoint. When the Event Recorder is disabled no new events are recorded. When the Event Recorder is enabled new events are recorded with the 150 most recent events displayed in **A3 POWER ANALYSIS** ⇨ ⇩ **EVENT RECORDER**. Refer to *Event Recorder* for the list of possible events. All data within the Event Recorder is stored in non-volatile memory.

## Trace Memory

PATH: SETPOINTS ⇨ S1 PQM II SETUP ⇨ TRACE MEMORY

<div style="border: 1px solid black; padding: 2px; display: inline-block;"> <span style="font-size: 1.2em;">■</span> TRACE MEMORY [▶]         </div>			<b>TRACE MEMORY USAGE:</b> <b>1 x 36 cycles</b>	<i>Range: 1 x 36, 2 x 18, 3 x 12 cycles</i>
MESSAGE			<b>TRACE MEMORY TRIGGER</b> <b>MODE: ONE SHOT</b>	<i>Range: One Shot, Retrigger</i>
MESSAGE			<b>Ia OVERCURRENT TRIG</b> <b>LEVEL: OFF % CT</b>	<i>Range: 1 to 150% of CT in steps of 1 or OFF</i>
MESSAGE			<b>Ib OVERCURRENT TRIG</b> <b>LEVEL: OFF % CT</b>	<i>Range: 1 to 150% of CT in steps of 1 or OFF</i>
MESSAGE			<b>Ic OVERCURRENT TRIG</b> <b>LEVEL: OFF % CT</b>	<i>Range: 1 to 150% of CT in steps of 1 or OFF</i>
MESSAGE			<b>In OVERCURRENT TRIG</b> <b>LEVEL: OFF % CT</b>	<i>Range: 1 to 150% of CT in steps of 1 or OFF</i>
MESSAGE			<b>Va OVERVOLTAGE TRIG</b> <b>LEVEL: OFF % NOMINAL</b>	<i>Range: 20 to 150% of Nominal in steps of 1 or OFF</i>
MESSAGE			<b>Vb OVERVOLTAGE TRIG</b> <b>LEVEL: OFF % NOMINAL</b>	<i>Range: 20 to 150% of Nominal in steps of 1 or OFF</i>
MESSAGE			<b>Vc OVERVOLTAGE TRIG</b> <b>LEVEL: OFF % NOMINAL</b>	<i>Range: 20 to 150% of Nominal in steps of 1 or OFF</i>
MESSAGE			<b>Va UNDERVOLTAGE TRIG</b> <b>LEVEL: OFF % NOMINAL</b>	<i>Range: 20 to 150% of Nominal in steps of 1 or OFF</i>
MESSAGE			<b>Vb UNDERVOLTAGE TRIG</b> <b>LEVEL: OFF % NOMINAL</b>	<i>Range: 20 to 150% of Nominal in steps of 1 or OFF</i>
MESSAGE			<b>Vc UNDERVOLTAGE TRIG</b> <b>LEVEL: OFF % NOMINAL</b>	<i>Range: 20 to 150% of Nominal in steps of 1 or OFF</i>
MESSAGE			<b>SWITCH INPUT A TRIG:</b> <b>OFF</b>	<i>Range: Off, Open-to-Closed, Closed-to-Open</i>
MESSAGE			<b>SWITCH INPUT B TRIG:</b> <b>OFF</b>	<i>Range: Off, Open-to-Closed, Closed-to-Open</i>
MESSAGE			<b>SWITCH INPUT C TRIG:</b> <b>OFF</b>	<i>Range: Off, Open-to-Closed, Closed-to-Open</i>
MESSAGE			<b>SWITCH INPUT D TRIG:</b> <b>OFF</b>	<i>Range: Off, Open-to-Closed, Closed-to-Open</i>
MESSAGE			<b>TRACE MEMORY TRIGGER</b> <b>DELAY: 0 cycles</b>	<i>Range: 0 to 30 cycles in steps of 2</i>
MESSAGE			<b>TRACE MEMORY TRIGGER</b> <b>RELAY: OFF</b>	<i>Range: Off, Aux1, Aux2, Aux3, Alarm</i>

The Trace Memory feature involves a separate sampling data stream. All input channels are sampled continuously at a rate of 16 times per cycle. Using a single-cycle block interval, the input samples are checked for trigger conditions as per the

trigger setpoints below. Note that the normal sampling burst (64 samples/cycle, 2 cycles) used for all metering calculations is done on top of the trace memory sampling. The harmonic analysis sampling (256 samples/cycles, 1 cycle) causes the trace memory sampling to stop for one cycle whenever a harmonic analysis is requested. Refer to *Trace Memory* for details on trace memory implementation in the EnerVista PQM Setup Software.

- **TRACE MEMORY USAGE:** The trace memory feature allows the user to capture maximum of 36 cycles. The **TRACE MEMORY USAGE** setpoint allows the buffer to be divided into maximum of 3 separate buffers as shown in table below.

Setpoint Value	Result
1 x 36 cycles	Upon a trigger, the entire buffer is filled with 36 cycles of data.
2 x 18 cycles	The buffer is split into 2 separate buffers and upon a trigger, the first buffer is filled with 18 cycles of data and upon a second trigger, the second buffer is filled with 18 cycles of data.
3 x 12 cycles	The buffer is split into 3 separate buffers and upon a trigger, the first buffer is filled with 12 cycles of data, upon a second trigger, the second buffer is filled with 12 cycles of data and upon a third trigger, the third buffer is filled with 12 cycles of data.

- **TRACE MEMORY TRIGGER MODE:** The trace memory can be configured to trigger in two different modes as described in the table below.

Setpoint Value	Result
One Shot	The trace memory will be triggered once per buffer as defined in the TRACE MEMORY USAGE setpoint above. In order for it to re-trigger, it must be re-armed through the serial port using the EnerVista PQM Setup Software or other software. Once re-armed the trace memory will default back to the first buffer.
Retrigger	The trace memory will automatically re-trigger upon each condition and overwrite the previous buffer data.

- **Ia/Ib/Ic/In OVERCURRENT TRIG LEVEL:** Once the phase A/B/C/neutral current equals or increases above this setpoint value, the trace memory is triggered and data on all inputs are captured in the buffer. The number of cycles captured depends on the value specified in the [TRACE MEMORY USAGE](#) setpoint.
- **Va/Vb/Vc OVERVOLTAGE TRIG LEVEL:** Once the phase A/B/C voltage equals or increases above this setpoint value, the trace memory is triggered and data on all inputs are captured in the buffer. The number of cycles captured depends on the value specified in the [TRACE MEMORY USAGE](#) setpoint. Phase to neutral levels are used regardless of the VT wiring.
- **Va/Vb/Vc UNDERVOLTAGE TRIG LEVEL:** Once the phase A/B/C voltage is equal to or less than this setpoint value, the trace memory is triggered and data on all inputs are captured in the buffer. The number of cycles captured depends on the value specified in the [TRACE MEMORY USAGE](#) setpoint.
- **SWITCH INPUT A(D) TRIG:** If the setpoint is set to “Open-to-Closed”, the trace memory is triggered and data on all inputs are captured in the buffer on a Switch A(D) close transition. If the setpoint is set to “Closed-to-Open”, the trace memory is triggered and data on all inputs are captured in the buffer on a Switch A(D) open transition. The number of cycles captured depends on the value specified in the [TRACE MEMORY USAGE](#) setpoint.
- **TRACE MEMORY TRIGGER DELAY:** In some applications it may be necessary to delay the trigger point to observe the data before the fault occurred. The PQM II allows the trigger to be delayed by the amount of cycles set in this setpoint. Therefore, buffer will always contain the number cycles specified in this setpoint before the trigger point and the remaining space in the buffer is filled with the cycles after the trigger point.
- **TRACE MEMORY TRIGGER RELAY:** The relay selected here will be activated upon the occurrence of a Trace Memory Trigger. This relay will be cleared once the Trace Memory is re-armed.

See *Triggered Trace Memory* for additional details on this feature.

## Programmable Message

PATH: SETPOINTS ⇨ S1 PQM II SETUP ⇨ PROGRAMMABLE MESSAGE

■ PROGRAMMABLE MESSAGE [▷]		PHONE: 905-294-6222 <u>www.GE</u> multilin.com	<i>Range:40 alphanumeric characters</i>
-------------------------------	---	---	---

A 40-character message can be programmed using the keypad, or via a serial port using the EnerVista PQM Setup Software. An example of writing a new message over the existing one is shown below:

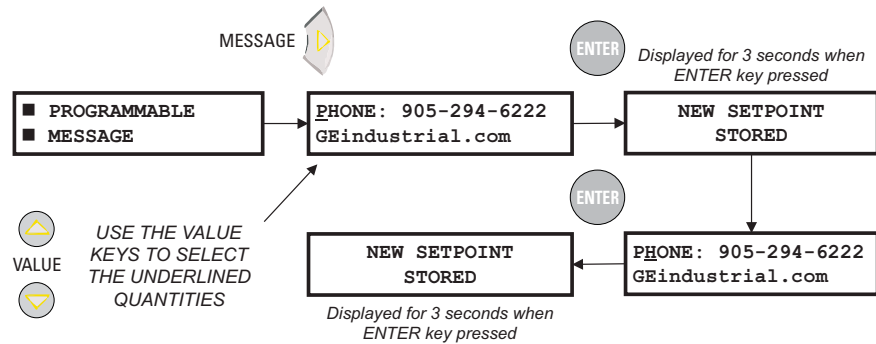







### TIPS:

- The setpoint access must be enabled in order to alter the characters.
- To skip over a character press the ENTER key.
- If a character is entered incorrectly, press the ENTER key repeatedly until the cursor returns to the position of the error, and re-enter the character.
- See *Default Messages* for details on selecting this message as a default message

A copy of this message is displayed in actual values page [A2 STATUS](#) ⇨ PROGRAMMABLE MESSAGE.

## Product Options

PATH: SETPOINTS ⇨ S1 PQM II SETUP ⇨ ↓ PRODUCT OPTIONS

■ PRODUCT OPTIONS [▷]		SELECT ORDER: PQMII-T20-C-A	<i>Range: see range in PQM II Modbus memory format code F116</i>
MESSAGE		SELECT MOD1 TO ENABLE: 0	<i>Range: 0 to 999 in steps of 1</i>
MESSAGE		SELECT MOD2 TO ENABLE: 0	<i>Range: 0 to 999 in steps of 1</i>
MESSAGE		SELECT MOD3 TO ENABLE: 0	<i>Range: 0 to 999 in steps of 1</i>
MESSAGE		SELECT MOD4 TO ENABLE: 0	<i>Range: 0 to 999 in steps of 1</i>
MESSAGE		SELECT MOD5 TO ENABLE: 0	<i>Range: 0 to 999 in steps of 1</i>
MESSAGE		ENTER PASSCODE: _	<i>Range: consult the factory</i>

The PQM II can have options and certain modifications upgraded on-site via use of a passcode provided by GE Vernova. Consult the factory for details on the use of this feature.

## S2 System Setup

### Current and Voltage Configuration

The shaded setpoints below must be set to a value other than “Off” to clear the Critical Setpoints Not Stored alarm.

PATH: SETPOINTS ⇨ S2 SYSTEM SETUP ⇨ CURRENT/VOLTAGE CONFIG.

<p>■ CURRENT/ VOLTAGE CONFIG. [▶]</p>	<p>PHASE CT WIRING: Phases A, B, AND C</p>	<p>Range:A, B, and C, A and B only, A and C only, A only</p>
<p>MESSAGE</p>	<p>PHASE CT PRIMARY: OFF A</p>	<p>Range:5 to 12000 A in steps of 5 or Off</p>
<p>MESSAGE</p>	<p>NEUTRAL CURRENT SENSING: OFF</p>	<p>Range:Off, Separate CT, Calculated</p>
<p>MESSAGE</p>	<p>NEUTRAL CT PRIMARY: 100 A</p>	<p>Range:5 to 6000 A in steps of 5</p>
<p>MESSAGE</p>	<p>VT WIRING: OFF</p>	<p>Range:Off, 4 Wire Wye / 3 VTs, 4 Wire Wye / Direct, 4 Wire Wye / 2 VTs, 3-Wire Delta / 2 VTs, 3 Wire Direct, Single Phase Direct</p>
<p>MESSAGE</p>	<p>VT RATIO: 1.0 : 1</p>	<p>Range:1.0 to 3500.0 in steps of 0.1</p>
<p>MESSAGE</p>	<p>VT NOMINAL SECONDARY VOLTAGE: 120 V</p>	<p>Range:40 to 600 V in steps of 1</p>
<p>MESSAGE</p>	<p>NOMINAL DIRECT INPUT VOLTAGE: 600 V</p>	<p>Range:40 to 600 V in steps of 1</p>
<p>MESSAGE</p>	<p>NOMINAL SYSTEM FREQUENCY: 60 Hz</p>	<p>Range:50 Hz, 60 Hz</p>

- PHASE CT WIRING:** The table below indicates the required connection per setpoint setting.

Setpoint Value	Required CT Connection
A,B, and C	CTs are connected to phase A, B and C inputs.
A and B Only	CTs are connected to phase A and B only. Phase C input is left open. The value for phase C is calculated by the PQM II.
A and C Only	CTs are connected to phase A and C only. Phase B input is left open. The value for phase B is calculated by the PQM II.
A Only	CT is connected to phase A only. Phase B and C inputs are left open. The values for phase B and C are calculated by the PQM II.

If the “A and B Only”, “A and C Only”, or “A Only” connection is selected, the neutral sensing must be accomplished with a separate CT.

- PHASE CT PRIMARY:** Enter the primary current rating of the phase current transformers. All three phase CTs must have the same rating. For example, if 500:5 CTs are used, the **PHASE CT PRIMARY** value is entered as “500”. The **PHASE CT PRIMARY** factory default is “Off”. While set to “Off”, the PQM II is forced to an alarm state as a safety precaution until a valid CT value is entered. Ensure that the CT is connected to the correct 1 or 5 A terminals to match the CT secondary.
- NEUTRAL CURRENT SENSING:** Neutral current sensing can be accomplished by using a separate external CT connection or by calculations. Select “Separate CT” when using an external CT. If “Calculated” is selected, the PQM II calculates the neutral current using the vector sum of  $I_a + I_b + I_c = I_n$ . If a residual connection is required using the PQM II internal CT, the neutral CT primary must be the same as the phase CT primary to ensure correct readings.

- **NEUTRAL CT PRIMARY:** This message is visible only if the neutral current sensing setpoint is set to “Separate CT”. Enter the CT primary current. For example, if a 50:5 CT is installed for neutral sensing enter 50. One amp CTs can also be used for neutral sensing.
- **VT WIRING:** Enter the VT connection of the system in this setpoint. The three possible wiring configurations are Wye, Delta, and Single Phase. If the system to be measured has a Wye connection:

Wye Connection	Usage
3 Wire Direct	For systems that are 600 V or less and directly connected to the PQM II
4 Wire Wye Direct	For systems that are 600 V or less and directly connected to the PQM II
4 Wire Wye / 3 VTs	For systems with external VTs
4 Wire Wye / 2 VTs	For systems with external VTs

The **VT NOMINAL SECONDARY VOLTAGE** setpoint is replaced by **NOMINAL DIRECT INPUT VOLTAGE**. With external VTs (depending upon how many external VTs are used), the “4 Wire Wye / 3 VTs” or “4 Wire Wye / 2 VTs” value must be selected. Note that when using the “4 Wire Wye / 2 VTs” value, only two voltages are measured; the third voltage is calculated on the assumption that  $V_{an} + V_{bn} + V_{cn} = 0$ . This assumption is valid only for balanced system voltages.

If the system to be measured has a Delta connection,:

Delta Connection
3 Wire Delta / 2 VTs







The PQM II accepts input voltages from 0 to 600 V AC between any two of the voltage terminals (V1, V2, V3, and Vn). These inputs can be directly connected or supplied via external VTs. External VTs are required for input voltages greater than 600 V AC (line-to-line). When measuring line-to-line quantities using inputs V1, V2 and V3, ensure that the voltage common input Vn is grounded. This input is used as a reference for measuring the voltage inputs.

All connections to the PQM II voltage inputs should be connected using HRC fuses rated at 2 amps to ensure adequate interrupting capacity.

- **VT RATIO:** Enter the voltage transformer ratio. All three voltage inputs must be of the same rating. For example, if 4200:120 VTs are used, the **VT RATIO** should be  $4200 / 120 = 35.0:1$ . This setpoint is not visible if **VT WIRING** is set to “3 Wire Direct”, “4 Wire Direct”, or “Single Phase Direct”.
- **VT NOMINAL SECONDARY VOLTAGE:** Enter the nominal secondary of the VTs. If the voltage inputs are directly connected, enter the nominal system voltage that will be applied to the PQM II. This setpoint is not visible if the **VT WIRING** is set to “3 Wire Direct”, “4 Wire Direct”, or “Single Phase Direct”. This value is used to scale an analog output that is assigned to display voltage as a percentage of nominal.
- **NOMINAL DIRECT INPUT VOLTAGE:** This setpoint is displayed only if **VT WIRING** is selected as a direct connection. The nominal direct input voltage must be entered in this message. This value will be used to scale an analog output that is assigned to display voltage as a percentage of nominal.
- **NOMINAL SYSTEM FREQUENCY:** Enter the nominal system frequency. The PQM II measures frequency from the Van voltage and adjusts its internal sampling to best fit the measured frequency. If the Van input is unavailable, the PQM II will assume the frequency entered here.

## Analog Outputs

PATH: SETPOINTS ⇨ ↓ S2 SYSTEM SETUP ⇨ ↓ ANALOG OUTPUT 1(4)

■ ANALOG OUTPUT 1	[▷]		<b>ANALOG OUTPUT RANGE :</b> 4-20 mA	Range:0-20 mA, 4-20 mA. Seen only in the Analog Output 1 menu.
MESSAGE			<b>ANALOG OUTPUT 1 MAIN:</b> Not Used	Range:refer to the Analog Output Parameters table below
MESSAGE			<b>MAIN 4 mA VALUE :</b> 0	Range:refer to the Analog Output Parameters table below
MESSAGE			<b>MAIN 20 mA VALUE :</b> 0	Range:refer to the Analog Output Parameters table below
MESSAGE			<b>ANALOG OUTPUT 1 ALT:</b> NOT USED	Range:refer to the Analog Output Parameters table below
MESSAGE			<b>ALT 4 mA VALUE :</b> 0	Range:refer to the Analog Output Parameters table below
MESSAGE			<b>ALT 20 mA VALUE :</b> 0	Range:refer to the Analog Output Parameters table below

The PQM II has four (4) Analog Outputs configured through four setpoints pages. The **ANALOG OUTPUT RANGE** setpoint appears in the Analog Output 1 setpoints page only and applies to all four outputs.

- **ANALOG OUTPUT RANGE:** If the T20 option is installed, the Analog Outputs can be configured to operate as 4 to 20 mA current sources or 0 to 20 mA current sources. All four Analog Outputs will operate in the range defined by this setpoint.
- **ANALOG OUTPUT 1(4) MAIN / ANALOG OUTPUT 1(4) ALT:** If the PQM II is used in conjunction with programmable controllers, automated equipment, or a chart recorder, the analog outputs can be used for continuous monitoring. Although parameters can be selected for continuous analog output, all values are available digitally through the communications interface. Applications include using a computer to automatically shed loads as the frequency decreases by monitoring frequency or a chart recorder to plot the loading of a system in a particular process.

Each of the analog outputs can be assigned to two of the parameters listed in the Analog Output Parameters table. The analog output main selection is the default selection and a programmable switch input can be programmed to multiplex the **ANALOG OUTPUT 1(4) ALT** selection to the same output depending upon the open or closed state of the switch input. See *Switch Inputs* for details about configuring a switch input. If no switch input is assigned as an analog output multiplexer, the analog output main selection will be the only parameter which appears at the analog output terminals. The ability to multiplex two different analog output quantities on one analog output effectively gives the PQM II eight analog outputs. The table below shows the criteria used by the PQM II to decide whether the output is based on MAIN or ALT settings.

- **MAIN/ALT 4 mA VALUE:** This message appears for each analog output and allows the user to assign a numeric value which corresponds to the 4 mA end of the 4 to 20 mA signal range (T20 option) or the 0 mA end of the 0 to 1 mA signal range (T1 option). The numeric value range will depend upon which parameter is selected. See the *Analog Output Parameters* table below for details. Note that if the T20 option is installed and the **ANALOG OUTPUT RANGE** setpoint is set to “0-20 mA”, this message represents the 0 mA end of the signal range.

**Table 3: Analog Output Selection Criteria**

Condition Present	'Main' Parameter	'Alt' Parameter	Output Based On
Any condition	"Not Used"	"Not Used"	Main
Control option 'C' not installed	any	not available	Main
Switch assigned to <b>SELECT ANALOG OUTPUT</b> and is disabled	any	"Not Used"	Main
Switch assigned to <b>SELECT ANALOG OUTPUT</b> and is enabled	any	"Not Used"	Main
Any condition	"Not Used"	anything other than "Not Used"	Alt
Switch assigned to <b>SELECT ANALOG OUTPUT</b> and is disabled	"Not Used"	anything other than "Not Used"	Alt
Switch assigned to <b>SELECT ANALOG OUTPUT</b> and is enabled	any	anything other than "Not Used"	Alt

- MAIN/ALT 20 mA VALUE:** This message appears for each analog output and allows the user to assign a numeric value which corresponds to the 20 mA end of the 4 to 20 mA signal range (T20 option) or the 1 mA end of the 0 to 1 mA signal range (T1 option). The numeric value range will depend upon which parameter is selected. See the *Analog Output Parameters* table below.

If the 4 mA (or 0 mA) value is programmed to be higher than the 20 mA (or 1 mA) value, the analog output will decrease towards 4 mA (or 0 mA) as the value increases and the analog output will increase towards 20 mA (or 1 mA) as the value decreases. If the 4 mA (or 0 mA) and 20 mA (or 1 mA) values are programmed to an identical value, the output will always be 4 mA (or 0 mA).

**Table 4: Analog Output Parameters (Sheet 1 of 2)**

<b>Parameter</b>	<b>Range</b>	<b>Step</b>
Phase A Current	0 to 150%	1%
Phase B Current	0 to 150%	1%
Phase C Current	0 to 150%	1%
Neutral Current	0 to 150%	1%
Average Phase Current	0 to 150%	1%
Current Unbalance	0 to 100.0%	0.1%
Voltage Van	0 to 200%	1%
Voltage Vbn	0 to 200%	1%
Voltage Vcn	0 to 200%	1%
Voltage Vab	0 to 200%	1%
Voltage Vbc	0 to 200%	1%
Voltage Vca	0 to 200%	1%
Average Phase Voltage	0 to 200%	1%
Average Line Voltage	0 to 200%	1%
Voltage Unbalance	0 to 100.0%	0.1%
Frequency	00.00 to 75.00 Hz	0.01 Hz
3 Phase PF	0.01 lead to 0.01 lag	0.01
3 Phase kW	-32500 to +32500	1 kW
3 Phase kvar	-32500 to +32500	1 kvar
3 Phase kVA	0 to 65400	1 kVA
3 Phase MW	-3250.0 to +3250.0	0.1 MW
3 Phase Mvar	-3250.0 to +3250.0	0.1 Mvar
3 Phase MVA	0 to 6540.0	0.1 MVA
Phase A PF	0.01 lead to 0.01 lag	0.01
Phase A kW	-32500 to +32500	1 kW
Phase A kvar	-32500 to +32500	1 kvar
Phase A kVA	0 to 65400	1 kVA
Phase B PF	0.01 lead to 0.01 lag	0.01
Phase B kW	-32500 to +32500	1 kW
Phase B kvar	-32500 to +32500	1 kvar

**Table 4: Analog Output Parameters (Sheet 2 of 2)**















Parameter	Range	Step
Phase B kVA	0 to 65400	1 kVA
Phase C PF	0.01 lead to 0.01 lag	0.01
Phase C kW	-32500 to +32500	1 kW
Phase C kvar	-32500 to +32500	1 kvar
Phase C kVA	0 to 65400	1 kVA
3 Phase +kWh Used	0 to 65400	1 kWh
3 Phase +kvarh Used	0 to 65400	1 kvarh
3 Phase -kWh Used	0 to 65400	1 kWh
3 Phase -kvarh Used	0 to 65400	1 kvarh
3 Phase kVAh Used	0 to 65400	1 kVAh
Phase A Current Demand	0 to 7500	1 A
Phase B Current Demand	0 to 7500	1 A
Phase C Current Demand	0 to 7500	1 A
Neutral Current Demand	0 to 7500	1 A
3 Phase kW Demand	-32500 to +32500	1 kW
3 Phase kvar Demand	-32500 to +32500	1 kvar
3 Phase kVA Demand	0 to 65400	1 kVA
3 Phase Current THD	0.0 to 100%	0.1%
3 Phase Voltage THD	0.0 to 100%	0.1%
Phase A Current THD	0.0 to 100%	0.1%
Phase B Current THD	0.0 to 100%	0.1%
Phase C Current THD	0.0 to 100%	0.1%
Voltage Van THD	0.0 to 100%	0.1%
Voltage Vbn THD	0.0 to 100%	0.1%
Voltage Vcn THD	0.0 to 100%	0.1%
Voltage Vab THD	0.0 to 100%	0.1%
Voltage Vbc THD	0.0 to 100%	0.1%
Neutral Current THD	0.0 to 100%	0.1%
Serial Control	-32500 to +32500	1 Unit

When the Analog Output parameter is set to “Serial Control”, the analog output(s) reflect a value in proportion to the serial value written to a specific register within the PQM II memory map. The locations are as described in the table below.

Analog Output	Modbus Register	Register
Analog Output 1	Analog Output 1 Serial Value	1067
Analog Output 2	Analog Output 2 Serial Value	106F
Analog Output 3	Analog Output 3 Serial Value	1077
Analog Output 4	Analog Output 4 Serial Value	107F

## Analog Input





PATH: SETPOINTS ⇄ S2 SYSTEM SETUP ⇄ ANALOG INPUT

<div style="display: flex; align-items: center;"> <div style="margin-right: 10px;">■</div> <div style="margin-right: 10px;">ANALOG INPUT</div> <div style="border: 1px solid black; padding: 2px 5px;">[▷]</div> </div>		ANALOG IN MAIN/ALT SELECT RELAY: OFF	<i>Range: Aux1, Aux2, Aux3, Off.</i>
MESSAGE		ANALOG IN MAIN NAME: MAIN ANALOG INPUT	<i>Range: 20 alphanumeric characters</i>
MESSAGE		ANALOG IN MAIN UNITS:           Units	<i>Range: 10 alphanumeric characters</i>
MESSAGE		MAIN 4 mA VALUE: 0	<i>Range: 0 to 65000 in steps of 1</i>
MESSAGE		MAIN 20 mA VALUE: 0	<i>Range: 0 to 65000 in steps of 1</i>
MESSAGE		ANALOG IN MAIN: RELAY: OFF	<i>Range: Alarm, Aux1, Aux2, Aux3, Off</i>
MESSAGE		ANALOG IN MAIN LEVEL: 100 Units	<i>Range: 0 to 65000 in steps of 1</i>
MESSAGE		ANALOG IN MAIN DELAY: 10.0 s	<i>Range: 0.5 to 600.0 s in steps of 1</i>
MESSAGE		ANALOG IN ALT NAME: ALT ANALOG INPUT	<i>Range: 20 alphanumeric characters</i>
MESSAGE		ANALOG IN ALT UNITS:           Units	<i>Range: 10 alphanumeric characters</i>
MESSAGE		ALT 4 mA VALUE: 0	<i>Range: 0 to 65000 in steps of 1</i>
MESSAGE		ALT 20 mA VALUE: 0	<i>Range: 0 to 65000 in steps of 1</i>
MESSAGE		ANALOG IN ALT: RELAY: OFF	<i>Range: Alarm, Aux1, Aux2, Aux3, Off</i>
MESSAGE		ANALOG IN ALT LEVEL: 100	<i>Range: 0 to 65000 in steps of 1</i>
MESSAGE		ANALOG IN ALT DELAY: 10.0 s	<i>Range: 0.5 to 600.0 s in steps of 1</i>

- **ANALOG IN MAIN/ALT SELECT RELAY:** Select the output relay that is to be used to multiplex two analog input signals to the PQM II. If this setpoint is “Off”, the **MAIN** analog input setpoints will be used unless a switch input assigned to **SELECT ANALOG INPUT** is activated. For more information on multiplexing two analog inputs using one of the PQM II output relays, refer to *Switch Inputs (Optional)*.
- **ANALOG IN MAIN/ALT NAME:** This message allows the user to input a user defined 20 character alphanumeric name for the **MAIN** and **ALT** analog inputs. To enter the names, perform the following steps:
  - ▷ Allow access to setpoints by enabling setpoint access.
  - ▷ Select the Analog Input name message display under the **S2 SYSTEM SETUP** ⇒ **ANALOG INPUT** setpoints group.
  - ▷ Use the **VALUE** keys to change the blinking character over the cursor. A space is selected like a character.
  - ▷ Press the **ENTER** key to store the character and advance the cursor to the next position. To skip over a character press the **ENTER** key.
  - ▷ Continue entering characters and spaces until the desired message is displayed. If a character is entered incorrectly, press the **ENTER** key repeatedly until the cursor returns to the incorrect position and re-enter the character.
- **ANALOG IN MAIN/ALT UNITS:** This message allows the user to input a user defined 10 character alphanumeric name for the **MAIN** and **ALT** units. To enter the units, perform the same steps as shown for analog input name.
- **MAIN/ALT 4 mA VALUE:** This message appears for each analog input and allows the user to assign a numeric value which corresponds to the 4 mA end of the 4 to 20 mA signal range.
- **MAIN/ALT 20 mA VALUE:** This message appears for each analog input and allows the user to assign a numeric value which corresponds to the 20 mA end of the 4 to 20 mA signal range.
- **ANALOG IN MAIN/ALT RELAY:** Analog input **MAIN** and **ALT** detection can either be disabled, used as an alarm or as a process control. Set this setpoint to OFF if the feature is not required. Selecting “Alarm” causes the alarm relay to activate and displays an alarm message whenever a **MAIN** or **ALT** analog input condition exists. Selecting an auxiliary relay causes the selected auxiliary relay to activate with no message displayed. This is intended for process control.
- **ANALOG IN MAIN/ALT LEVEL:** When the measured **MAIN** or **ALT** analog input meets or exceeds the level set by this setpoint, a **MAIN** or **ALT** analog input condition will occur.
- **ANALOG IN MAIN/ALT DELAY:** If the **MAIN** or **ALT** analog input meets or exceeds the **ANALOG IN MAIN/ALT LEVEL** setpoint value and remains this way for the time delay programmed in this setpoint, an analog input condition will occur. If the **ANALOG IN MAIN/ALT RELAY** setpoint is set to “Alarm”, the alarm relay will activate and the **ANALOG IN MAIN/ALT ALARM** message will be displayed. If the setpoint **ANALOG IN MAIN/ALT RELAY** is set to “Aux1”, “Aux2”, or “Aux3”, the respective auxiliary relay will activate and no message will be displayed after the delay expires.

## Switch Inputs

PATH: SETPOINTS ⇨⇩ S2 SYSTEM SETUP ⇨⇩ SWITCH INPUT A(D)

■ SWITCH INPUT A [▷]		SWITCH A NAME: Switch Input A	Range:20 alphanumeric characters
MESSAGE		SWITCH A FUNCTION: NOT USED	Range:see description below
MESSAGE		SWITCH A ACTIVATION: OPEN	Range:Open, Closed
MESSAGE		SWITCH A TIME DELAY: 0.0 s	Range:0.0 to 600.0 s in steps of 1

There are four (4) Switch Inputs, denoted as Switch Input A, B, C, and D.

- SWITCH A(D) NAME:** This message allows the user to input a user defined 20-character alphanumeric name for each switch input. To enter a switch name, perform the following steps:
  - ▷ Allow access to setpoints by enabling setpoint access.
  - ▷ Select the switch input message display under the subgroup [S2 SYSTEM SETUP](#) ⇨⇩ [SWITCH INPUT A](#).
  - ▷ Use the VALUE keys to change the blinking character over the cursor. A space is selected like a character.
  - ▷ Press the ENTER key to store the character and advance the cursor to the next position. To skip over a character press the ENTER key.
  - ▷ Continue entering characters and spaces until the desired message is displayed. If a character is entered incorrectly, press the ENTER key repeatedly to return the cursor to the position of the error, and re-enter the character.
- SWITCH A(D) FUNCTION:** Select the required function for each switch input. See *Switch Inputs (Optional)* on page 2–12 for a description of each function. The “New Demand Period”, “Setpoint Access”, “Select Analog Out”, “Select Analog In”, “Pulse Input 1”, “Pulse Input 2”, “Pulse Input 3”, “Pulse Input 4”, “Clear Energy” and “Clear Demand” functions can be assigned to only one switch input at a time. If an attempt is made to assign one of these functions to more than one input, the **THIS SWITCH FUNCTION ALREADY ASSIGNED** flash message will be displayed. If an attempt is made via the serial port, no flash message will appear but an error code will be returned.
 

The range of functions for the [SWITCH A\(D\) FUNCTION](#) setpoint is: Not Used, Alarm, Aux1, Aux2, Aux3, New Demand Period, Setpoint Access, Select Analog Out, Select Analog In, Pulse Input 1, Pulse Input 2, Pulse Input 3, Pulse Input 4, Clear Energy, Clear Demand.
- SWITCH A(D) ACTIVATION:** This setpoint determines the operating sequence of the switch. Select “Open” if a switch activation is required for a switch input transition of closed to open. Select “Closed” if a switch activation is required for a switch input transition of open to closed.
- SWITCH A(D) TIME DELAY:** If the switch input function is assigned to “Alarm”, “Aux1”, “Aux2”, or “Aux3”, this message will be displayed. Enter the required time delay in this message.

## Pulse Output

PATH: SETPOINTS ⇌ S2 SYSTEM SETUP ⇌ PULSE OUTPUT

■ PULSE OUTPUT	[▷]		POS kWh PULSE OUTPUT RELAY: OFF	Range: Alarm, Aux1, Aux2, Aux3, Off
MESSAGE			POS kWh PULSE OUTPUT INTERVAL: 100 kWh	Range: 1 to 65000 kWh in steps of 1
MESSAGE			NEG kWh PULSE OUTPUT RELAY: Off	Range: Alarm, Aux1, Aux2, Aux3, Off
MESSAGE			NEG kWh PULSE OUTPUT INTERVAL: 100 kWh	Range: 1 to 65000 kWh in steps of 1
MESSAGE			POS kvarh PULSE OUTPUT RELAY: OFF	Range: Alarm, Aux1, Aux2, Aux3, Off
MESSAGE			POS kvarh PULSE OUTPUT INTERVAL: 100 kvarh	Range: 1 to 65000 kvarh in steps of 1
MESSAGE			NEG kvarh PULSE OUTPUT RELAY: OFF	Range: Alarm, Aux1, Aux2, Aux3, Off
MESSAGE			NEG kvarh PULSE OUTPUT INTERVAL: 100 kvarh	Range: 1 to 65000 kvarh in steps of 1
MESSAGE			kVAh PULSE OUTPUT RELAY: OFF	Range: Alarm, Aux1, Aux2, Aux3, Off
MESSAGE			kVAh PULSE OUTPUT INTERVAL: 100 kVAh	Range: 1 to 65000 kVAh in steps of 1
MESSAGE			PULSE WIDTH: 100 ms	Range: 100 to 2000 ms in steps of 10

- **kWh / kvarh / kVAh PULSE OUTPUT RELAY:** Five pulse output parameters can be assigned to the alarm or auxiliary relays. They are positive kWh, negative kWh, positive kvarh, negative kvarh, and kVAh. Enter the desired relay to which each parameter is assigned. Select “Off” if a particular output parameter is not required.
- **kWh / kvarh / kVAh PULSE OUTPUT INTERVAL:** Enter the interval for the appropriate quantity at which the relay pulse will occur. The pulse width is set by the [PULSE WIDTH](#) setpoint described below. If the pulse interval is set to “100 kWh”, one pulse will indicate that 100kWh has been accumulated.
- **PULSE WIDTH:** This setpoint determines the duration of each pulse as shown in the figure below.

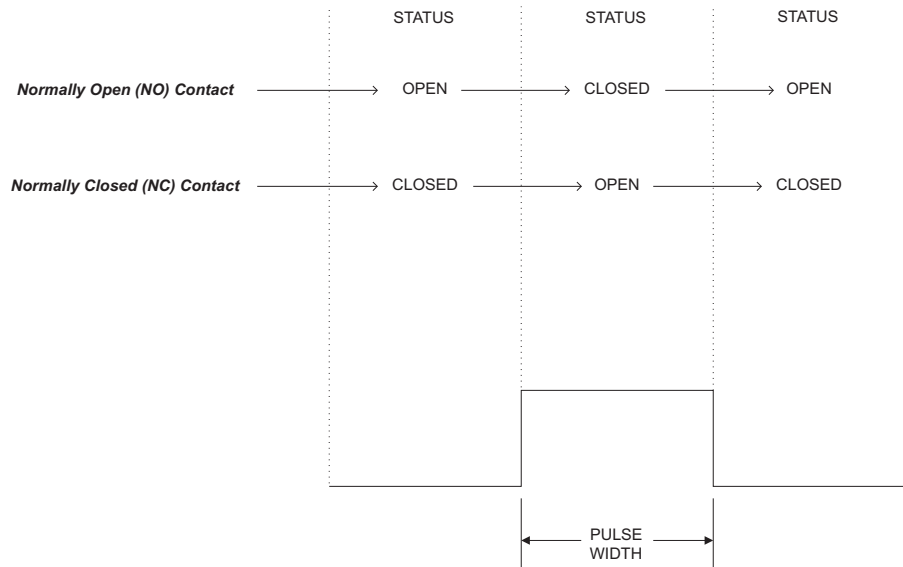

FIGURE 5-2: Pulse Output Timing

## Pulse Input

PATH: SETPOINTS ⇄ S2 SYSTEM SETUP ⇄ PULSE INPUT



<div style="border: 1px solid black; padding: 2px;"> <span style="background-color: black; color: white; padding: 0 5px;">■</span> PULSE INPUT [▷]             </div>	<div style="border: 1px solid black; padding: 2px;">                 PULSE INPUT                  UNITS:       Units             </div>	<i>Range:10 alphanumeric characters</i>
MESSAGE	<div style="border: 1px solid black; padding: 2px;">                 PULSE INPUT 1 VALUE:                            1 Units             </div>	<i>Range:0 to 65000 in steps of 1</i>
MESSAGE	<div style="border: 1px solid black; padding: 2px;">                 PULSE INPUT 2 VALUE:                            1 Units             </div>	<i>Range:0 to 65000 in steps of 1</i>
MESSAGE	<div style="border: 1px solid black; padding: 2px;">                 PULSE INPUT 3 VALUE:                            1 Units             </div>	<i>Range:0 to 65000 in steps of 1</i>
MESSAGE	<div style="border: 1px solid black; padding: 2px;">                 PULSE INPUT 4 VALUE:                            1 Units             </div>	<i>Range:0 to 65000 in steps of 1</i>
MESSAGE	<div style="border: 1px solid black; padding: 2px;">                 PULSE INPUT TOTAL:                            1+2+3+4             </div>	<i>Range:1+2, 1+3, 1+4, 2+3, 2+4, 3+4, 1+2+3, 1+3+4, 1+2+4, 2+3+4, 1+2+3+4</i>

- PULSE INPUT UNITS:** This message allows the user to input a user defined 10 character alphanumeric unit for the pulse inputs (i.e. kWh). The unit will be used by all pulse inputs including the totalized value. To enter the unit, perform the following steps:
  - ▷ Allow access to setpoints by enabling setpoint access.
  - ▷ Select the **PULSE INPUT UNITS** setpoint.
  - ▷ Use the **VALUE** keys to change the blinking character over the cursor. A space is selected like a character.
  - ▷ Press the **ENTER** key to store the character and advance the cursor to the next position. To skip over a character press the **ENTER** key.

- ▷ Continue entering characters and spaces until the desired message is displayed. If a character is entered incorrectly, press the ENTER key repeatedly until the cursor returns to the incorrect position and re-enter the character.
- **PULSE INPUT 1(4) VALUE:** Enter a value in this setpoint that will be equivalent to 1 pulse input on the switch input assigned to Pulse Input 1(4); i.e., 1 pulse = 100 kWh. The accumulated value is displayed in actual values under **A1 METERING** ⇨⇩ **PULSE INPUT COUNTERS** ⇨⇩ **PULSE INPUT 1(4)**.
- **PULSE INPUT TOTAL:** This setpoint defines which pulse inputs to add together. For example, if the selection in this setpoint is “1+2+3”, the **PULSE INPUT 1**, **PULSE INPUT 2** and **PULSE INPUT 3** values shown in **A1 METERING** ⇨⇩ **PULSE INPUT COUNTERS** ⇨⇩ **PULSE INPUT 1(4)** will be added together and displayed in **A1 METERING** ⇨⇩ **PULSE INPUT COUNTERS** ⇨⇩ **PULSE IN 1+2+3**.

## Data Logger



PATH: SETPOINTS ⇨⇩ S2 SYSTEM SETUP ⇨⇩ DATA LOGGER

<div style="border: 1px solid black; padding: 5px;"> <span style="font-size: 24px;">■</span> DATA LOGGER [▷]             </div>		STOP DATA LOG 1: NO (STOPPED)	<i>Range: No, Yes</i>
	MESSAGE 	STOP DATA LOG 2: NO (STOPPED)	<i>Range: No, Yes</i>

The data logger operation is only configurable using the EnerVista PQM Setup Software. On occasions it may be necessary to stop the data loggers using the PQM II keypad and then a computer to extract the logged information. The **STOP DATA LOG 1(2)** setpoints allow the user to stop the respective data log. These setpoints also display the current status of the respective data logger. Refer to *Data Logger Implementation* for a detailed implementation description.

## Voltage Disturbance

PATH: SETPOINTS ⇨⇩ S2 SYSTEM SETUP ⇨⇩ VOLTAGE DIST. RECORDER

<div style="border: 1px solid black; padding: 5px;"> <span style="font-size: 24px;">■</span> VOLTAGE DIST. RECORDER [▷]             </div>		SAG LEVEL ≤ 80% Nominal	<i>Range: 20 to 90% of Nominal VT in steps of 1</i>
	MESSAGE 	SWELL LEVEL ≥ 130% Nominal	<i>Range: 110 to 150% of Nominal VT in steps of 1</i>

- **SAG LEVEL:** When the voltage on any phase drops below this level a Sag condition occurs. During this condition, the average voltage and duration of the disturbance are calculated. The condition ends when the level increases to at least 10% of nominal plus pickup of the **SAG LEVEL** setting. This hysteresis is implemented to avoid nuisance alarms due to voltage fluctuations. If the duration logged was less than or equal to 1 minute an event with a sag type will be logged. If the duration was greater than 1 minute an event with an undervoltage type will be logged when this feature is configured.
- **SWELL LEVEL:** When the voltage on any phase increases above this level a swell condition occurs. During a swell condition the average voltage and duration of the disturbance are calculated. To end a Swell condition the level must decrease to pickup minus 10% of nominal of the **SWELL LEVEL** setting. This hysteresis is implemented to avoid nuisance alarms due to voltage fluctuations. If the duration logged was less than or equal to 1 minute an event with a swell type

will be logged. If the duration was greater than 1 minute an event with an overvoltage type will be logged when this feature is configured.

## S3 Output Relays

### Description

Output relay operation in the PQM II occurs in either 'failsafe' or 'non-failsafe' modes, as defined below:

- **Non-failsafe:** The relay coil is not energized in its non-active state. Loss of control power will cause the relay to remain in the non-active state. That is, a non-failsafe alarm relay will not cause an alarm on loss of control power. Contact configuration in the Wiring Diagrams is shown with relays programmed non-failsafe and control power not applied.
- **Failsafe:** The relay coil is energized in its non-active state. Loss of control power will cause the relay to go into its active state. That is, a failsafe alarm relay will cause an alarm on loss of control power. Contact configuration is opposite to that shown in the Wiring Diagrams for relays programmed as failsafe when control power is applied.

### Alarm Relay

PATH: SETPOINTS ⇌ S3 OUTPUT RELAYS ⇌ ALARM RELAY

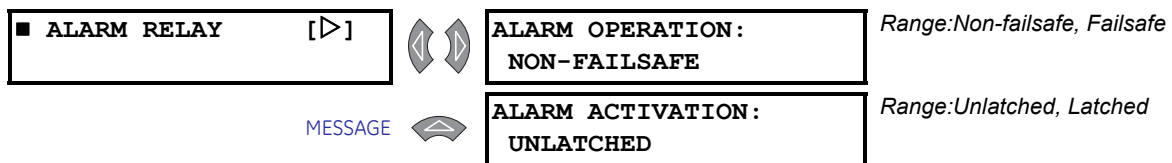

- **ALARM OPERATION:** The terms 'failsafe' and 'non-failsafe' are defined above as implemented in the PQM II. If an alarm is required when the PQM II is not operational due to a loss of control power, select failsafe operation. Otherwise, choose non-failsafe.
- **ALARM ACTIVATION:** If an alarm indication is required only while an alarm is present, select unlatched. Once the alarm condition disappears, the alarm and associated message automatically clear. To ensure all alarms are acknowledged, select latched. Even if an alarm condition is no longer present, the alarm relay and message can only be cleared by pressing the key or by sending the reset command via the computer.

### Auxiliary Relays

PATH: SETPOINTS ⇌ S3 OUTPUT RELAYS ⇌ AUXILIARY RELAY 1(3)

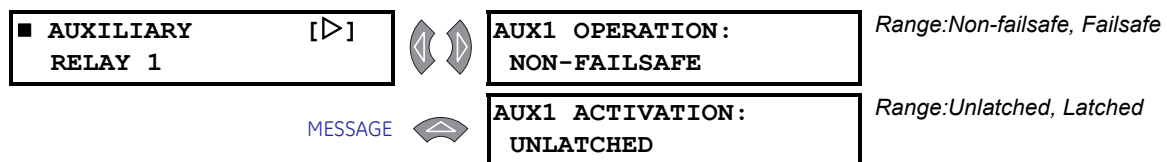

The PQM II contains three (3) auxiliary relays, denoted as Aux1 through Aux3. The terms 'failsafe' and 'non-failsafe' are defined in the previous section.

- **AUXILIARY 1(3) OPERATION:** If an output is required when the PQM II is not operational due to a loss of control power, select failsafe auxiliary operation, otherwise, choose non-failsafe.
- **AUXILIARY 1(3) ACTIVATION:** If an auxiliary relay output is only required while the selected conditions are present, select “Unlatched”. Once the selected condition disappears, the auxiliary relay returns to the non-active state. To ensure all conditions are acknowledged, select “Latched”. If the condition is no longer present, the auxiliary relay can be reset by pressing the key or by sending the reset command via the computer.

The PQM II uses a priority system to determine which function will control the relays if they happen to be assigned to more than one function.



















The Pulse Output function has the highest activation priority, followed by the Analog Input Main/Alt Select functions. The alarm functions have the lowest priority. For example, if a relay is assigned to an alarm function and also assigned to one of the pulse output parameters, it only responds to the pulse output function.

## S4 Alarms/Control

### Current/Voltage Alarms

PATH: SETPOINTS ⇄ S4 ALARMS/CONTROL ⇄ CURRENT/VOLTAGE

<div style="border: 1px solid black; padding: 2px;"> <span style="background-color: black; color: white; padding: 0 5px;">■</span> CURRENT/ VOLTAGE                 </div>	[▷]		<div style="border: 1px solid black; padding: 2px;">                     DETECT I/V ALARMS USING PERCENTAGE: NO                 </div>	Range:No, Yes
MESSAGE			<div style="border: 1px solid black; padding: 2px;">                     PHASE UNDERCURRENT RELAY: OFF                 </div>	Range:Alarm, Aux1, Aux2, Aux3, Off
MESSAGE			<div style="border: 1px solid black; padding: 2px;">                     PHASE UNDERCURRENT LEVEL ≤ 100 A                 </div>	Range:1 to 12000 A in steps of 1, or 1 to 100% of CT in steps of 1, set by the DETECT I/V ALARMS USING PERCENTAGE value.
MESSAGE			<div style="border: 1px solid black; padding: 2px;">                     PHASE UNDERCURRENT DELAY: 10.0 s                 </div>	Range:0.5 to 600.0 s in steps of 0.5
MESSAGE			<div style="border: 1px solid black; padding: 2px;">                     DETECT UNDERCURRENT WHEN 0A: NO                 </div>	Range:No, Yes
MESSAGE			<div style="border: 1px solid black; padding: 2px;">                     PHASE OVERCURRENT RELAY: OFF                 </div>	Range:Alarm, Aux1, Aux2, Aux3, Off
MESSAGE			<div style="border: 1px solid black; padding: 2px;">                     PHASE OVERCURRENT LEVEL ≥ 100 A                 </div>	Range:1 to 12000 A in steps of 1, or 1 to 150% of CT in steps of 1, set by the DETECT I/V ALARMS USING PERCENTAGE value.
MESSAGE			<div style="border: 1px solid black; padding: 2px;">                     PHASE OVERCURRENT DELAY: 10.0 s                 </div>	Range:0.5 to 600.0 s in steps of 0.5
MESSAGE			<div style="border: 1px solid black; padding: 2px;">                     PHASE OVERCURRENT ACTIVATION: AVERAGE                 </div>	Range:Average, Maximum
MESSAGE			<div style="border: 1px solid black; padding: 2px;">                     NEUTRAL OVERCURRENT RELAY: OFF                 </div>	Range:Alarm, Aux1, Aux2, Aux3, Off

MESSAGE		<b>NEUTRAL OVERCURRENT LEVEL ≥ 100 A</b>	Range:1 to 12000 A in steps of 1, or 1 to 150% of CT in steps of 1, set by the <b>DETECT I/V ALARMS USING PERCENTAGE</b> value.
MESSAGE		<b>NEUTRAL OVERCURRENT DELAY: 10.0 s</b>	Range:0.5 to 600.0 s in steps of 0.5
MESSAGE		<b>UNDERVOLTAGE RELAY: OFF</b>	Range:Alarm, Aux1, Aux2, Aux3, Off
MESSAGE		<b>UNDERVOLTAGE LEVEL ≤ 100 V</b>	Range:20 to 65000 V in steps of 1, or 20 to 100% of VT in steps of 1, set by the <b>DETECT I/V ALARMS USING PERCENTAGE</b> value.
MESSAGE		<b>UNDERVOLTAGE DELAY: 10.0 s</b>	Range:0.5 to 600.0 s in steps of 0.5
MESSAGE		<b>PHASES REQ'D FOR U/V OPERATION: ANY ONE</b>	Range:Any One, Any Two, All Three. Not seen when <b>VT WIRING</b> is set to "Single Phase Direct"
MESSAGE		<b>DETECT UNDERVOLTAGE BELOW 20V: NO</b>	Range:No, Yes
MESSAGE		<b>OVERVOLTAGE RELAY: OFF</b>	Range:Alarm, Aux1, Aux2, Aux3, Off
MESSAGE		<b>OVERVOLTAGE LEVEL ≥ 100 V</b>	Range:20 to 65000 V in steps of 1, or 20 to 150% of VT in steps of 1, set by the <b>DETECT I/V ALARMS USING PERCENTAGE</b> value.
MESSAGE		<b>OVERVOLTAGE DELAY: 10.0 s</b>	Range:0.5 to 600.0 s in steps of 0.5
MESSAGE		<b>PHASES REQ'D FOR O/V OPERATION: ANY ONE</b>	Range:Any One, Any Two, All Three. Not seen when <b>VT WIRING</b> is set to "Single Phase Direct"
MESSAGE		<b>CURRENT UNBALANCE RELAY: OFF</b>	Range:Alarm, Aux1, Aux2, Aux3, Off
MESSAGE		<b>CURRENT UNBALANCE LEVEL ≥ 100%</b>	Range:1 to 100% in steps of 1
MESSAGE		<b>CURRENT UNBALANCE DELAY: 10.0 s</b>	Range:0.5 to 600.0 s in steps of 0.5
MESSAGE		<b>VOLTAGE UNBALANCE RELAY: OFF</b>	Range:Alarm, Aux1, Aux2, Aux3, Off
MESSAGE		<b>VOLTAGE UNBALANCE LEVEL ≥ 100%</b>	Range:1 to 100% in steps of 1
MESSAGE		<b>VOLTAGE UNBALANCE DELAY: 10.0 s</b>	Range:0.5 to 600.0 s in steps of 0.5
MESSAGE		<b>VOLTS PHASE REVERSAL RELAY: OFF</b>	Range:Alarm, Aux1, Aux2, Aux3, Off

MESSAGE 

<b>VOLTS PHASE REVERSAL</b>	<i>Range:0.5 to 600.0 s in steps of 0.5</i>
<b>DELAY: 1.0 s</b>	

- **DETECT I/V ALARMS USING PERCENTAGE:** When “Yes” is selected, all current and voltage alarms can be set in percentages of CT and VT. When “No” is selected, all current and voltage alarms are actual voltage and current levels.
- **PHASE UNDERCURRENT RELAY:** Undercurrent can be disabled, used as an alarm, or as a process control feature. Set this setpoint to “Off” if the feature is not required. Selecting “Alarm” activates the alarm relay and displays an alarm message whenever an undercurrent condition exists. Selecting an auxiliary relay activates the selected auxiliary relay for an undercurrent condition but no message will be displayed. This is intended for process control.
- **PHASE UNDERCURRENT LEVEL:** When the average three phase current drops to or below the level set by this setpoint, a phase undercurrent condition will occur. Refer to the [DETECT UNDERCURRENT WHEN 0A](#) setpoint description below to enable/disable undercurrent detection below 5% of CT.
- **PHASE UNDERCURRENT DELAY:** If the average phase current is less than or equal to the [PHASE UNDERCURRENT LEVEL](#) setpoint value for the time delay programmed in this setpoint, a phase undercurrent condition will occur.
- **DETECT UNDERCURRENT WHEN 0A:** If this setpoint is set to “Yes”, undercurrent will be detected if the average phase current drops below 5% of CT. If the setting is “No”, the undercurrent detection is only enabled if the average phase current is equal to or above 5% of CT.
- **PHASE OVERCURRENT RELAY:** Overcurrent can either be disabled, used as an alarm or as a process control. Set this setpoint to “Off” if the feature is not required. Selecting “Alarm” activates the alarm relay and displays an alarm message whenever an overcurrent condition exists. Selecting an auxiliary relay activates the auxiliary relay for an overcurrent condition but no message will be displayed. This is intended for process control.
- **PHASE OVERCURRENT LEVEL:** When the average (or maximum, see below) three phase current equals or exceeds the level set by this setpoint, a phase overcurrent condition will occur.
- **PHASE OVERCURRENT DELAY:** If the average (or maximum, see below) phase current equals or exceeds the [PHASE OVERCURRENT LEVEL](#) setpoint value and remains this way for the time delay programmed in this setpoint, a phase overcurrent condition will occur.
- **PHASE OVERCURRENT ACTIVATION:** The Phase Overcurrent function can use either the average phase current or the maximum of the three phase currents. This setpoint determines which is used.
- **NEUTRAL OVERCURRENT RELAY:** Neutral overcurrent can be disabled, used as an alarm, or used as a process control. Set this setpoint to “Off” if the feature is not required. Selecting “Alarm” activates the alarm relay and displays an alarm message whenever a neutral overcurrent condition exists. Selecting an auxiliary relay activates the auxiliary relay for a neutral overcurrent condition but no message will be displayed. This is intended for process control.
- **NEUTRAL OVERCURRENT LEVEL:** When the neutral current equals or exceeds the level set by this setpoint, a neutral overcurrent condition will occur.
- **NEUTRAL OVERCURRENT DELAY:** If the neutral current greater than or equal to the [NEUTRAL OVERCURRENT LEVEL](#) setpoint value for the time delay programmed in this setpoint, a neutral overcurrent condition will occur.
- **UNDERVOLTAGE RELAY:** Undervoltage can either be disabled, used as an alarm, or as a process control. Set this setpoint to “Off” if the feature is not required. Selecting “Alarm” activates the alarm relay and displays an alarm

message whenever an undervoltage condition exists. Selecting an auxiliary relay activates the auxiliary relay for an undervoltage condition but no message will be displayed. This is intended for process control.

- **UNDERVOLTAGE LEVEL:** When the voltage on one, two, or three phases drops to or below this level, an undervoltage condition occurs. The required number of phases is determined by the [PHASES REQUIRED FOR U/V OPERATION](#) setpoint. To clear the undervoltage condition, the level must increase to 103% of the [UNDERVOLTAGE LEVEL](#) setting. For example, if the [UNDERVOLTAGE LEVEL](#) is “4000 V”, the condition clears when the voltage in the appropriate phase(s) increases above 4120 V ( $4000 \times 1.03$ ). This hysteresis is implemented to avoid nuisance alarms due to voltage fluctuations.
- **UNDERVOLTAGE DELAY:** If the voltage drops to or below the [UNDERVOLTAGE LEVEL](#) setpoint value and remains this way for the time delay programmed in this setpoint, an undervoltage condition will occur.
- **PHASES REQ'D FOR U/V OPERATION:** Select the minimum number of phases on which the undervoltage condition must be detected before the selected output relay will operate. This setpoint is not visible if [VT WIRING](#) is set to “Single Phase Direct”.
- **DETECT UNDERVOLTAGE BELOW 20V:** If an indication is required for loss of voltage, select “Yes”. If “No” is selected and any one of the voltage inputs has less than 20 V applied, the undervoltage feature will be disabled.
- **OVERVOLTAGE RELAY:** Overvoltage can either be disabled, used as an alarm, or as a process control. Set this setpoint to “Off” if the feature is not required. Selecting “Alarm” activates the alarm relay and displays an alarm message whenever an overvoltage condition exists. Selecting an auxiliary relay activates the auxiliary relay for an overvoltage condition but no message will be displayed. This is intended for process control.
- **OVERVOLTAGE LEVEL:** When the voltage on one, two, or three phases equals or exceeds the level determined with this setpoint, an overvoltage condition occurs. The required number of phases is determined by the [PHASES REQUIRED FOR O/V OPERATION](#) setpoint. To clear the overvoltage condition, the level must decrease to 97% of the [OVERVOLTAGE LEVEL](#) setting. For example, if the [OVERVOLTAGE LEVEL](#) is set to “4200 V”, the condition clears when the voltage in the appropriate phase(s) goes below 4074 V ( $4200 \times 0.97$ ). This hysteresis is implemented to avoid nuisance alarms due to voltage fluctuations.
- **OVERVOLTAGE DELAY:** If the voltage equals or exceeds the [OVERVOLTAGE LEVEL](#) setpoint value for the time delay programmed in this setpoint, an overvoltage condition will occur.
- **PHASES REQ'D FOR O/V OPERATION:** Select the minimum number of phases on which the overvoltage condition must be detected before the selected output relay operates. This setpoint is not visible if [VT WIRING](#) is set to “Single Phase Direct”.
- **CURRENT UNBALANCE RELAY:** Current unbalance is calculated as the maximum deviation from the average divided by the average three phase current. Current unbalance can either be disabled, used as an alarm, or as a process control. Set this setpoint to “Off” if the feature is not required. Selecting “Alarm” activates the alarm relay and displays an alarm message whenever a current unbalance condition exists. Selecting an auxiliary relay activates the auxiliary relay for a current unbalance condition but no message will be displayed. This is intended for process control.
- **CURRENT UNBALANCE LEVEL:** When the current unbalance equals or exceeds this level, a current unbalance condition will occur. See *Current Metering* for details on the method of calculation.

- **CURRENT UNBALANCE DELAY:** If the current unbalance equals or exceeds the **CURRENT UNBALANCE LEVEL** value for the time delay programmed in this setpoint, a current unbalance condition occurs.
- **VOLTAGE UNBALANCE RELAY:** Voltage unbalance is calculated as the maximum deviation from the average divided by the average three phase voltage. Voltage unbalance can either be disabled, used as an alarm, or as a process control. Set this setpoint to “Off” if the feature is not required. Selecting “Alarm” activates the alarm relay and displays an alarm message whenever a voltage unbalance condition exists. Selecting an auxiliary relay activates the auxiliary relay for a voltage unbalance condition but no message will be displayed. This is intended for process control.
- **VOLTAGE UNBALANCE LEVEL:** When the voltage unbalance equals or exceeds this level, a voltage unbalance condition occurs. See *Voltage Metering* for details on the method of calculation.
- **VOLTAGE UNBALANCE DELAY:** If the voltage unbalance equals or exceeds the **VOLTAGE UNBALANCE LEVEL** setpoint value and remains this way for the time delay programmed in this setpoint, a voltage unbalance condition will occur.
- **VOLTAGE PHASE REVERSAL:** Under normal operating conditions, the PQM II expects to see the voltages connected with a 1-2-3 or A-B-C sequence. If the voltages are connected with the wrong sequence (e.g. 2-1-3 or B-A-C), a voltage phase reversal condition will occur. A minimum of 20 V must be applied to the PQM II on all voltage inputs before the phase reversal feature will operate.

A phase reversal condition is determined by looking at the phase angle at the occurrence of the peak sample of phase B voltage and subtracting it from the phase angle at the peak sample of phase A voltage (phase A angle – phase B angle). This angle is averaged over several cycles before deciding on the condition to avoid any false triggering of the feature. Only two phases are required to detect phase reversal because all phase reversal conditions can be covered without the use of the third phase. The angle to detect phase reversal will vary depending on the connection being used as described below.

For “4-Wire Wye / 3 VTs”, “4 Wire Wye / 2 VTs”, “4 Wire Direct”, and “3 Wire Direct” connections, the phase reversal function operates when the angle between phase A and B becomes  $\leq -150^\circ$  or  $\geq -90^\circ$  as shown below.

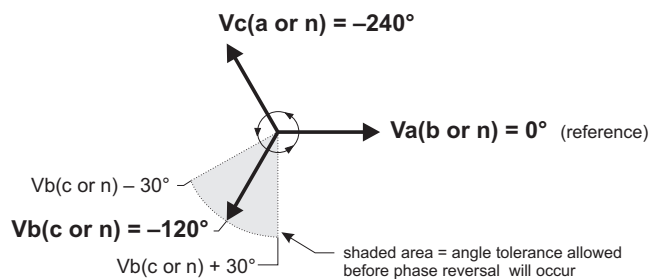

FIGURE 5-3: Phase Reversal for 4-wire and 3-wire Direct Connections

For the “3 Wire Delta / 2 VTs” connection, the phase reversal function operates when the angle between phase A and B is  $\leq 30^\circ$  or  $\geq 90^\circ$  as shown below.

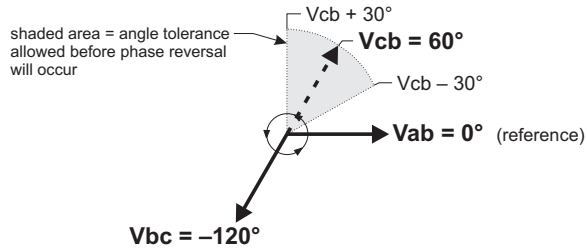

FIGURE 5-4: Phase Reversal for 3-wire Delta (2 VTs Open-Delta) Wiring

When the “Single Phase Direct” connection is used the phase reversal feature will never operate.

- **VOLTAGE PHASE REVERSAL DELAY:** If a voltage phase reversal exists for the time programmed in this setpoint a voltage phase reversal condition will occur.

Please note that the terms undervoltage and overvoltage used for alarm, are generic regardless of sag/swell or undervoltage/overvoltage conditions based on duration of the voltage disturbance

## Harmonic Distortion

PATH: SETPOINTS ⇄ S4 ALARMS/CONTROL ⇄ TOTAL HARMONIC DISTORTION

<b>■ TOTAL HARMONIC DISTORTION</b> [▷]		<b>AVERAGE CURRENT THD RELAY: OFF</b>	<i>Range: Alarm, Aux1, Aux2, Aux3, Off</i>
MESSAGE		<b>AVERAGE CURRENT THD LEVEL ≥ 10.0 %</b>	<i>Range: 0.5 to 100.0% in steps of 0.5</i>
MESSAGE		<b>AVERAGE CURRENT THD DELAY: 10.0 s</b>	<i>Range: 0.5 to 600.0 s in steps of 0.5</i>
MESSAGE		<b>AVERAGE VOLTAGE THD RELAY: OFF</b>	<i>Range: Alarm, Aux1, Aux2, Aux3, Off</i>
MESSAGE		<b>AVERAGE VOLTAGE THD LEVEL ≥ 10.0 %</b>	<i>Range: 0.5 to 100.0% in steps of 0.5</i>
MESSAGE		<b>AVERAGE VOLTAGE THD DELAY: 10.0 s</b>	<i>Range: 0.5 to 600.0 s in steps of 0.5</i>

- **AVERAGE CURRENT THD RELAY:** Excessive phase current THD detection can either be disabled, used as an alarm, or as a process control. Set this setpoint to “Off” if the feature is not required. Selecting “Alarm” activates the alarm relay and displays an alarm message whenever an excessive average current THD condition exists. Selecting an auxiliary relay activates the auxiliary relay, but no message will be displayed. This is intended for process control.
- **AVERAGE CURRENT THD LEVEL:** When the measured average current THD exceeds this setpoint value, an average current THD condition occurs.

- **AVERAGE CURRENT THD DELAY:** If the average current THD exceeds the **AVERAGE CURRENT THD LEVEL** for the time delay programmed in this setpoint, an average current THD condition occurs.
- **AVERAGE VOLTAGE THD RELAY:** Average voltage THD detection can either be disabled, used as an alarm or as a process control. Set this setpoint to off if the feature is not required. Selecting alarm relay will cause the alarm relay to activate and display an alarm message whenever an average voltage THD condition exists. Selecting auxiliary relay will cause the auxiliary relay to activate, but no message will be displayed. This is intended for process control.
- **AVERAGE VOLTAGE THD LEVEL:** When the measured average voltage THD equals or exceeds this setpoint value, an Average Voltage THD condition occurs.
- **AVERAGE VOLTAGE THD DELAY:** If the average voltage THD equals or exceeds the **AVERAGE VOLTAGE THD LEVEL** value and remains this way for the time delay programmed in this setpoint, an Average Voltage THD condition will occur.

## Frequency

PATH: SETPOINTS ⇄ S4 ALARMS/CONTROL ⇄ FREQUENCY

■ FREQUENCY	[▷]	UNDERFREQUENCY RELAY: OFF	<i>Range: Alarm, Aux1, Aux2, Aux3, Off</i>
MESSAGE		UNDERFREQUENCY LEVEL ≤ 40.00 Hz	<i>Range: 20.00 to 70.00 Hz in steps of 0.01</i>
MESSAGE		UNDERFREQUENCY DELAY: 1.0 s	<i>Range: 0.1 to 10.0 s in steps of 0.1</i>
MESSAGE		UNDERFREQUENCY WHEN FREQUENCY=0 Hz: NO	<i>Range: Yes, No</i>
MESSAGE		OVERFREQUENCY RELAY: OFF	<i>Range: Alarm, Aux1, Aux2, Aux3, Off</i>
MESSAGE		OVERFREQUENCY LEVEL ≥ 70.00 Hz	<i>Range: 20.00 to 125.00 Hz in steps of 0.01</i>
MESSAGE		OVERFREQUENCY DELAY: 1.0 s	<i>Range: 0.1 to 10.0 s in steps of 0.1</i>

- **UNDERFREQUENCY RELAY:** Underfrequency detection can either be disabled or used as an alarm, or process control. Set this setpoint to “Off” if the feature is not required. Selecting alarm relay will cause the alarm relay to activate and display an alarm message whenever an underfrequency condition exists. Selecting an auxiliary relay activates the auxiliary relay for an underfrequency condition, but no message will be displayed. This is intended for process control.
- **UNDERFREQUENCY LEVEL:** When the measured frequency drops to or below the level set by this setpoint, an underfrequency condition will occur.
- **UNDERFREQUENCY DELAY:** If the underfrequency drops to or below the **UNDERFREQUENCY LEVEL** value for the time delay programmed in this setpoint, an underfrequency condition will occur.
- **UNDERFREQUENCY WHEN FREQ=0 Hz:** A voltage greater than 20 V is required on phase AN (AB) voltage input before frequency can be measured. If no voltage is applied or if the voltage applied is less than 20 V, the displayed frequency will be 0 Hz. If “No” is selected in this setpoint, an underfrequency condition will not occur when the displayed frequency is 0 Hz.

- **OVERFREQUENCY RELAY:** Overfrequency detection can either be disabled, used as an alarm or as a process control. Set this setpoint to off if the feature is not required. Selecting alarm relay will cause the alarm relay to activate and display an alarm message whenever an overfrequency condition exists. Selecting auxiliary relay will cause the auxiliary relay to activate for an overfrequency condition, but no message will be displayed. This is intended for process control.
- **OVERFREQUENCY LEVEL:** When the measured frequency equals or exceeds the level set by this setpoint, an overfrequency condition will occur.
- **OVERFREQUENCY DELAY:** If the overfrequency equals or exceeds the **OVERFREQUENCY LEVEL** setpoint value for the time delay programmed in this setpoint, an overfrequency condition will occur.

## Power Alarms

PATH: SETPOINTS ⇄ S4 ALARMS/CONTROL ⇄ POWER

■ POWER [▷]		<b>POWER ALARMS LEVEL</b> BASE UNIT(S) : kW/kvar	Range:kW/kvar, MW, Mvar
MESSAGE		<b>POSITIVE REAL POWER</b> RELAY: OFF	Range:Alarm, Aux1, Aux2, Aux3, Off
MESSAGE		<b>POSITIVE REAL POWER</b> LEVEL ≥ 1000 kW	Range:1 to 65000 kW in steps of 1, or 0.01 to 650.00 MW in steps of 0.01
MESSAGE		<b>POSITIVE REAL POWER</b> DELAY: 10.0 s	Range:0.5 to 600.0 s in steps of 0.5
MESSAGE		<b>NEGATIVE REAL POWER</b> RELAY: OFF	Range:Alarm, Aux1, Aux2, Aux3, Off
MESSAGE		<b>NEGATIVE REAL POWER</b> LEVEL ≥ 1000 kW	Range:1 to 65000 kW in steps of 1, or 0.01 to 650.00 MW in steps of 0.01
MESSAGE		<b>NEGATIVE REAL POWER</b> DELAY: 10.0 s	Range:0.5 to 600.0 s in steps of 0.5
MESSAGE		<b>POSITIVE REACT POWER</b> RELAY: OFF	Range:Alarm, Aux1, Aux2, Aux3, Off
MESSAGE		<b>POSITIVE REACT POWER</b> LEVEL ≥ 1000 kvar	Range:1 to 65000 kvar in steps of 1, or 0.01 to 650.00 Mvar in steps of 0.01
MESSAGE		<b>POSITIVE REACT POWER</b> DELAY: 10.0 s	Range:0.5 to 600.0 s in steps of 0.5
MESSAGE		<b>NEGATIVE REACT POWER</b> RELAY: OFF	Range:Alarm, Aux1, Aux2, Aux3, Off
MESSAGE		<b>NEGATIVE REACT POWER</b> LEVEL ≥ 1000 kvar	Range:1 to 65000 kvar in steps of 1, or 0.01 to 650.00 Mvar in steps of 0.01
MESSAGE		<b>NEGATIVE REACT POWER</b> DELAY: 10.0 s	Range:0.5 to 600.0 s in steps of 0.5

- **POWER ALARMS LEVEL BASE UNIT(S):** This setpoint is used to select the base unit multiplier for all power alarms. When set to kW/kvar, all power alarm

levels can be set in terms of kW and kvar with a step value of 1 kW/kvar. When set to MW/Mvar, all power alarm levels can be set in terms of MW and Mvar with a step value of 0.01 MW/Mvar.

- **POSITIVE/NEGATIVE REAL POWER RELAY:** The positive and negative real power level detection can be disabled, used as an alarm, or used as a process control. The “Off” setting disables this feature. Selecting “Alarm” activates the alarm relay and displays an alarm message whenever a positive/negative real power level exceeds the selected level. Selecting an auxiliary relay activates the auxiliary relay for a set level of positive/negative real power but no message will be displayed. This is intended for process control.
- **POSITIVE/NEGATIVE REAL POWER LEVEL:** When the three phase real power equals or exceeds the level defined by this setpoint, an excess positive/negative real power condition will occur.
- **POSITIVE/NEGATIVE REAL POWER DELAY:** If the positive/negative real power equals or exceeds the **POSITIVE/NEGATIVE REAL POWER LEVEL** setpoint value for the time delay programmed in this setpoint, an excessive positive/negative real power condition will occur.
- **POSITIVE/NEGATIVE REACTIVE POWER RELAY:** Positive and negative reactive power level detection can either be disabled, used as an alarm, or as a process control. Set this setpoint to “Off” if the feature is not required. Selecting “Alarm” activates the alarm relay and displays an alarm message whenever a positive/negative reactive power level exceeds the selected level. Selecting an auxiliary relay activates the auxiliary relay for a set level of positive/negative reactive power but no message will be displayed. This is intended for process control.
- **POSITIVE/NEGATIVE REACTIVE POWER LEVEL:** When the three phase reactive power equals or exceeds the level set by this setpoint, an excess positive/negative reactive power condition will occur.
- **POSITIVE/NEGATIVE REACTIVE POWER DELAY:** If the positive reactive power equals or exceeds the **POSITIVE/NEGATIVE REACTIVE POWER LEVEL** setpoint value for the time delay programmed in this setpoint, an excessive positive reactive power condition will occur.

## Power Factor

PATH: SETPOINTS ⇌ S4 ALARMS/CONTROL ⇌ POWER FACTOR

■ POWER FACTOR [▷]				
			<b>POWER FACTOR LEAD 1 RELAY: OFF</b>	<i>Range: Alarm, Aux1, Aux2, Aux3, Off</i>
MESSAGE			<b>POWER FACTOR LEAD 1 PICKUP ≤ 0.99</b>	<i>Range: 0.50 to 1.00 in steps of 0.01</i>
MESSAGE			<b>POWER FACTOR LEAD 1 DROPOUT ≥ 1.00</b>	<i>Range: 0.50 to 1.00 in steps of 0.01</i>
MESSAGE			<b>POWER FACTOR LEAD 1 DELAY: 10.0 s</b>	<i>Range: 0.5 to 600.0 s in steps of 0.5</i>
MESSAGE			<b>POWER FACTOR LAG 1 RELAY: Off</b>	<i>Range: Alarm, Aux1, Aux2, Aux3, Off</i>
MESSAGE			<b>POWER FACTOR LAG 1 PICKUP ≤ 0.99</b>	<i>Range: 0.50 to 1.00 in steps of 0.01</i>
MESSAGE			<b>POWER FACTOR LAG 1 DROPOUT ≥ 1.00</b>	<i>Range: 0.50 to 1.00 in steps of 0.01</i>
MESSAGE			<b>POWER FACTOR LAG 1 DELAY: 10.0 s</b>	<i>Range: 0.5 to 600.0 s in steps of 0.5</i>
MESSAGE			<b>POWER FACTOR LEAD 2 RELAY: OFF</b>	<i>Range: Alarm, Aux1, Aux2, Aux3, Off</i>
MESSAGE			<b>POWER FACTOR LEAD 2 PICKUP ≤ 0.99</b>	<i>Range: 0.50 to 1.00 in steps of 0.01</i>
MESSAGE			<b>POWER FACTOR LEAD 2 DROPOUT ≥ 1.00</b>	<i>Range: 0.50 to 1.00 in steps of 0.01</i>
MESSAGE			<b>POWER FACTOR LEAD 2 DELAY: 10.0 s</b>	<i>Range: 0.5 to 600.0 s in steps of 0.5</i>
MESSAGE			<b>POWER FACTOR LAG 2 RELAY: OFF</b>	<i>Range: Alarm, Aux1, Aux2, Aux3, Off</i>
MESSAGE			<b>POWER FACTOR LAG 2 PICKUP ≤ 0.99</b>	<i>Range: 0.50 to 1.00 in steps of 0.01</i>
MESSAGE			<b>POWER FACTOR LAG 2 DROPOUT ≥ 1.00</b>	<i>Range: 0.50 to 1.00 in steps of 0.01</i>
MESSAGE			<b>POWER FACTOR LAG 2 DELAY: 10.0 s</b>	<i>Range: 0.5 to 600.0 s in steps of 0.5</i>

It is generally desirable for a system operator to maintain the power factor as close to unity as possible (that is, to make the real power of the system as close as possible to the apparent power) to minimize both costs and voltage excursions. On dedicated circuits such as some large motors, with a near-fixed load, a capacitor bank may be switched on or off with the motor to supply leading vars to compensate for the lagging vars required by the motor. Since the power factor is variable on common non-dedicated circuits, it is advantageous to compensate for low (lagging) power factor

values by connecting a capacitor bank to the circuit when required. The PQM II provides power factor monitoring and allows two stages of capacitance switching for power factor compensation.

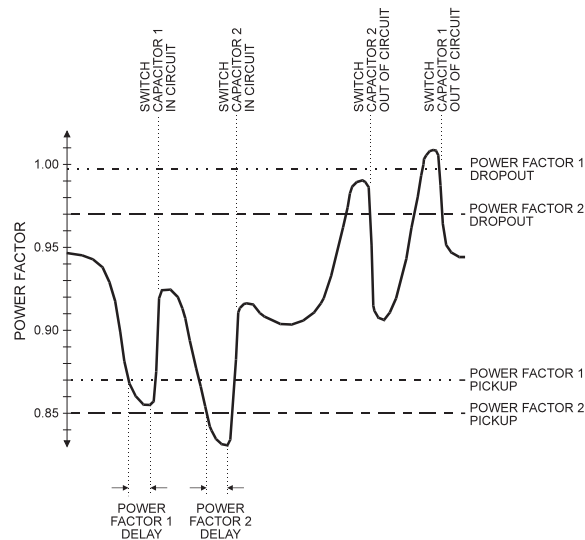

FIGURE 5-5: Capacitor Bank Switching

The PQM II calculates the average power factor in the three phases, according to the following equation:

$$\text{Average Power Factor} = \frac{\text{Total 3-phase Real Power}}{\text{Total 3-phase Apparent Power}} \quad (\text{EQ 5.2})$$

Two independent 'elements' are available for monitoring power factor, Power Factor 1 and Power Factor 2, each having a pickup and a dropout level. For each element, when the measured power factor is equal to or becomes more lagging than the pickup level (i.e. numerically less than), the PQM II will operate a user-selected output relay. This output can be used to control a switching device which connects capacitance to the circuit, or to signal an alarm to the system operator. After entering this state, when the power factor becomes less lagging than the power factor dropout level, the PQM II will reset the output relay to the non-operated state.

Both Power Factor 1 and 2 features are inhibited from operating unless all three voltages are above 20% of nominal and one or more currents is above 0. Power factor 1 and 2 delay timers will be allowed to time only when the 20% threshold is exceeded on all phases (and, of course, only while the power factor remains outside of the programmed pickup and dropout levels). In the same way, when a power factor condition starts the power factor 1 or 2 delay timer, if all three phase voltages fall below the 20% threshold before the timer has timed-out, the element will reset without operating. A loss of voltage during any state will return both Power Factor 1 and 2 to the reset state.

- **POWER FACTOR LEAD 1(2) RELAY:** Power factor detection can either be disabled, used as an alarm or as a process control. Set this setpoint to "Off" if the feature is not required. Selecting "Alarm" activates the alarm relay and displays an alarm message when the power factor is more leading than the level set. Selecting "Aux1", "Aux2", or "Aux3" activates the respective auxiliary relay when

the power factor is equal to or more leading than the level set, but no message will be displayed. This is intended for process control. A minimum of 20 V applied must exist on all voltage inputs before this feature will operate.

- **POWER FACTOR LEAD 1(2) PICKUP:** When a leading power factor equals or exceeds the level set by this setpoint, a Power Factor Lead 1(2) condition will occur.
- **POWER FACTOR LEAD 1(2) DROPOUT:** When a leading power factor drops below this level, the Power Factor Lead 1(2) condition will drop out.
- **POWER FACTOR LEAD 1(2) DELAY:** If the power factor equals or exceeds the [POWER FACTOR LEAD 1\(2\) PICKUP](#) setpoint value and remains this way for the time delay programmed in this setpoint, a Power Factor Lead 1(2) condition will occur. If the power factor drops below the [POWER FACTOR LEAD 1\(2\) DROPOUT](#) setpoint value, the power factor lead 1(2) condition will drop out. If the [POWER FACTOR LEAD 1\(2\) RELAY](#) setpoint is set to “Alarm”, the alarm relay will deactivate and the **POWER FACTOR LEAD 1(2) ALARM** message will be cleared. If the [POWER FACTOR LEAD 1\(2\) RELAY](#) setpoint is set to “Aux1”, “Aux2”, or “Aux3,” the respective auxiliary relay deactivates.
- **POWER FACTOR LAG 1(2) RELAY:** Power factor detection can either be disabled, used as an alarm or as a process control. Set this setpoint to “Off” if the feature is not required. Selecting “Alarm” activates the alarm relay and displays an alarm message when the power factor is more lagging than the level set. Selecting “Aux1”, “Aux2”, or “Aux3” activates the respective auxiliary relay when the power factor is equal to or more lagging than the level set, but no message will be displayed. This is intended for process control. A minimum of 20 V applied must exist on all voltage inputs before this feature will operate.
- **POWER FACTOR LAG 1(2) PICKUP:** When a lagging power factor equals or exceeds the level set by this setpoint, a Power Factor Lag 1(2) condition will occur.
- **POWER FACTOR LAG 1(2) DROPOUT:** When a lagging power factor drops below this level, the Power Factor Lag 1(2) condition will drop out.
- **POWER FACTOR LAG 1(2) DELAY:** If the power factor equals or exceeds the [POWER FACTOR LAG 1\(2\) PICKUP](#) setpoint value and remains this way for the time delay programmed in this setpoint, a Power Factor Lag 1(2) condition will occur. If the power factor drops below the [POWER FACTOR LAG 1\(2\) DROPOUT](#) setpoint value, the Power Factor 1(2) lag condition will drop out. If the [POWER FACTOR LAG 1\(2\) RELAY](#) setpoint is set to “Alarm”, the alarm relay will deactivate and the **POWER FACTOR LAG 1(2) ALARM** message will be cleared. If the [POWER FACTOR LAG 1\(2\) RELAY](#) setpoint is set to “Aux1”, “Aux2”, or “Aux3”, the respective auxiliary relay will deactivate.

## Demand Alarms

PATH: SETPOINTS ⇄ S4 ALARMS/CONTROL ⇄ DEMAND

■ DEMAND	[▷]		PHASE A CURRENT DMD RELAY: OFF	<i>Range: Alarm, Aux1, Aux2, Aux3, Off</i>
	MESSAGE		PHASE A CURRENT DMD LEVEL ≥ 100 A	<i>Range: 10 to 7500 A in steps of 1</i>
	MESSAGE		PHASE B CURRENT DMD RELAY: OFF	<i>Range: Alarm, Aux1, Aux2, Aux3, Off</i>
	MESSAGE		PHASE B CURRENT DMD LEVEL ≥ 100 A	<i>Range: 10 to 7500 A in steps of 1</i>
	MESSAGE		PHASE C CURRENT DMD RELAY: OFF	<i>Range: Alarm, Aux1, Aux2, Aux3, Off</i>
	MESSAGE		PHASE C CURRENT DMD LEVEL ≥ 100 A	<i>Range: 10 to 7500 A in steps of 1</i>
	MESSAGE		NEUTRAL CURRENT DMD RELAY: OFF	<i>Range: Alarm, Aux1, Aux2, Aux3, Off</i>
	MESSAGE		NEUTRAL CURRENT DMD LEVEL ≥ 100 A	<i>Range: 10 to 7500 A in steps of 1</i>
	MESSAGE		3Φ POS REAL PWR DMD RELAY: OFF	<i>Range: Alarm, Aux1, Aux2, Aux3, Off</i>
	MESSAGE		3Φ POS REAL PWR DMD LEVEL ≥ 1000 kW	<i>Range: 1 to 65000 kW in steps of 1</i>
	MESSAGE		3Φ POS REACT PWR DMD RELAY: OFF	<i>Range: Alarm, Aux1, Aux2, Aux3, Off</i>
	MESSAGE		3Φ POS REACT PWR DMD LEVEL ≥ 1000 kvar	<i>Range: 1 to 65000 kvar in steps of 1</i>
	MESSAGE		3Φ NEG REAL PWR DMD RELAY: OFF	<i>Range: Alarm, Aux1, Aux2, Aux3, Off</i>
	MESSAGE		3Φ NEG REAL PWR DMD LEVEL ≥ 1000 kW	<i>Range: 1 to 65000 kW in steps of 1</i>
	MESSAGE		3Φ NEG REACT PWR DMD RELAY: OFF	<i>Range: Alarm, Aux1, Aux2, Aux3, Off</i>
	MESSAGE		3Φ NEG REACT PWR DMD LEVEL ≥ 1000 kvar	<i>Range: 1 to 65000 kvar in steps of 1</i>
	MESSAGE		3Φ APPARENT PWR DMD RELAY: OFF	<i>Range: Alarm, Aux1, Aux2, Aux3, Off</i>
	MESSAGE		3Φ APPARENT PWR DMD LEVEL ≥ 1000 kVA	<i>Range: 1 to 65000 kVA in steps of 1</i>















- PHASE A/B/C/NEUTRAL CURRENT DMD RELAY:** Phase/neutral current demand detection can either be disabled or used as an alarm or process control. Set this setpoint to “Off” if the feature is not required. Selecting “Alarm” activates the alarm relay and displays an alarm message whenever a phase/neutral current

demand level is equalled or exceeded. Selecting “Aux1”, “Aux2”, or “Aux3” activates the respective auxiliary relay with no message displayed. This is intended for process control.

- **PHASE A/B/C/NEUTRAL CURRENT DMD LEVEL:** When the phase A/B/C/ or neutral current demand equals or exceeds this setpoint, a phase A/B/C or neutral demand alarm or process control indication occurs.
- **3 $\Phi$  POS/NEG REAL PWR DMD RELAY:** Three-phase positive/negative real power demand detection can either be disabled or used as an alarm or process control. Set this setpoint to “Off” if the feature is not required. Selecting “Alarm” activates the alarm relay and displays an alarm message whenever the positive/negative three-phase real power demand level is equalled or exceeded. Selecting “Aux1”, “Aux2”, or “Aux3” activates the respective auxiliary relay with no message displayed. This is intended for process control.
- **3 $\Phi$  POS/NEG REAL PWR DMD LEVEL:** When the three-phase real power demand exceeds this setpoint, a three-phase positive/negative real power demand alarm or process control indication will occur.
- **3 $\Phi$  POS/NEG REACT PWR DMD RELAY:** Three-phase positive/negative reactive power demand detection can either be disabled or used as an alarm or process control. Set to “Off” if this feature is not required. Selecting “Alarm” activates the alarm relay and displays an alarm message whenever the positive/negative three-phase reactive power demand level is equalled or exceeded. Selecting “Aux1”, “Aux2”, or “Aux3” activates the respective auxiliary relay with no message displayed. This is intended for process control.
- **3 $\Phi$  POS/NEG REACT PWR DMD LEVEL:** When the three-phase reactive power demand equals or exceeds this setpoint, a three-phase positive/negative reactive power demand alarm or process control indication will occur.
- **3 $\Phi$  APPARENT POWER DEMAND RELAY:** Three-phase apparent power demand detection can be disabled or used as an alarm or process control. Set to “Off” if this feature is not required. Selecting “Alarm” activates the alarm relay and displays an alarm message if the three-phase apparent power demand level is equalled or exceeded. Selecting “Aux1”, “Aux2”, or “Aux3” activates the respective auxiliary relay with no message displayed. This is intended for process control.
- **3 $\Phi$  APPARENT POWER DEMAND LEVEL:** When the three-phase apparent power demand equals or exceeds this setpoint, a three-phase apparent power alarm or process control indication will occur.

## Pulse Input

PATH: SETPOINTS ↓ S4 ALARMS/CONTROL ⇨ PULSE INPUT

<div style="border: 1px solid black; padding: 2px; display: inline-block;"> <span style="font-size: 0.8em;">■ PULSE INPUT</span> <span style="margin-left: 10px;">[▷]</span> </div>			<div style="border: 1px solid black; padding: 2px;"> <b>PULSE INPUT 1</b>  <b>RELAY: OFF</b> </div>	<i>Range: Alarm, Aux1, Aux2, Aux3, Off</i>
MESSAGE		<div style="border: 1px solid black; padding: 2px;"> <b>PULSE INPUT 1 LEVEL</b>  <b>≥ 100 Units</b> </div>	<i>Range: 1 to 65000 in steps of 1</i>	
MESSAGE		<div style="border: 1px solid black; padding: 2px;"> <b>PULSE INPUT 1</b>  <b>DELAY: 10.0 s</b> </div>	<i>Range: 0.5 to 600.0 s in steps of 0.5</i>	
MESSAGE		<div style="border: 1px solid black; padding: 2px;"> <b>PULSE INPUT 2</b>  <b>RELAY: OFF</b> </div>	<i>Range: Alarm, Aux1, Aux2, Aux3, Off</i>	
MESSAGE		<div style="border: 1px solid black; padding: 2px;"> <b>PULSE INPUT 2 LEVEL</b>  <b>≥ 100 Units</b> </div>	<i>Range: 1 to 65000 in steps of 1</i>	
MESSAGE		<div style="border: 1px solid black; padding: 2px;"> <b>PULSE INPUT 2</b>  <b>DELAY: 10.0 s</b> </div>	<i>Range: 0.5 to 600.0 s in steps of 0.5</i>	
MESSAGE		<div style="border: 1px solid black; padding: 2px;"> <b>PULSE INPUT 3</b>  <b>RELAY: OFF</b> </div>	<i>Range: Alarm, Aux1, Aux2, Aux3, Off</i>	
MESSAGE		<div style="border: 1px solid black; padding: 2px;"> <b>PULSE INPUT 3 LEVEL</b>  <b>≥ 100 Units</b> </div>	<i>Range: 1 to 65000 in steps of 1</i>	
MESSAGE		<div style="border: 1px solid black; padding: 2px;"> <b>PULSE INPUT 3</b>  <b>DELAY: 10.0 s</b> </div>	<i>Range: 0.5 to 600.0 s in steps of 0.5</i>	
MESSAGE		<div style="border: 1px solid black; padding: 2px;"> <b>PULSE INPUT 4</b>  <b>RELAY: OFF</b> </div>	<i>Range: Alarm, Aux1, Aux2, Aux3, Off</i>	
MESSAGE		<div style="border: 1px solid black; padding: 2px;"> <b>PULSE INPUT 4 LEVEL</b>  <b>≥ 100 Units</b> </div>	<i>Range: 1 to 65000 in steps of 1</i>	
MESSAGE		<div style="border: 1px solid black; padding: 2px;"> <b>PULSE INPUT 4</b>  <b>DELAY: 10.0 s</b> </div>	<i>Range: 0.5 to 600.0 s in steps of 0.5</i>	
MESSAGE		<div style="border: 1px solid black; padding: 2px;"> <b>TOTALIZED PULSES</b>  <b>RELAY: OFF</b> </div>	<i>Range: Alarm, Aux1, Aux2, Aux3, Off</i>	
MESSAGE		<div style="border: 1px solid black; padding: 2px;"> <b>TOTAL PULSES LEVEL</b>  <b>≥ 100 Units</b> </div>	<i>Range: 1 to 65000 in steps of 1</i>	
MESSAGE		<div style="border: 1px solid black; padding: 2px;"> <b>TOTALIZED PULSES</b>  <b>DELAY: 10.0 s</b> </div>	<i>Range: 0.5 to 600.0 s in steps of 0.5</i>	

- PULSE INPUT 1(4) RELAY:** Any of the PQM II switch inputs can be assigned to count pulse inputs as shown in *Switch Inputs*. This setpoint can be used to give an indication (alarm or control) if the programmed level is equaled or exceeded. Set this setpoint to “Off” if the feature is not required. Selecting “Alarm” activates the alarm relay and displays an alarm message whenever a pulse count level equals or exceeds the selected level. Selecting “Aux1”, “Aux2”, or “Aux3” activates the appropriate auxiliary relay but no message is displayed. The “Aux1”, “Aux2”, and “Aux3” selections are intended for process control.
- PULSE INPUT 1(4) LEVEL:** When the pulse input value accumulated in the **A1 METERING** ⇨ **PULSE COUNTER** ⇨ **PULSE INPUT 1(4)** actual value equals or exceeds this setpoint value, the relay assigned in the **PULSE INPUT 1(4) RELAY** will energize. If the “Alarm” relay is assigned, a **PULSE INPUT 1(4) ALARM** message will also be

displayed. The units in this setpoint are determined by the [S2 SYSTEM SETUP](#) ⇒ [PULSE INPUT](#) ⇒ [PULSE INPUT UNITS](#) setpoint.

- **PULSE INPUT 1(4) DELAY:** This setpoint can be used to allow a time delay before the assigned relay will energize after the [PULSE INPUT 1\(4\) LEVEL](#) has been equaled or exceeded.
- **TOTALIZED PULSES RELAY:** A relay can be selected to operate based upon a Total Pulse Input Count as configured in the PQM II. Selecting “Alarm” activates the alarm relay and displays an alarm message whenever a pulse count level equals or exceeds the selected level. Selecting “Aux1”, “Aux2”, or “Aux3” activates the appropriate auxiliary relay but no message will be displayed. The “Aux1”, “Aux2”, and “Aux3” selections are intended for process control.
- **TOTAL PULSES LEVEL:** When the pulse input value accumulated in the [A1 METERING](#) ⇒ [PULSE COUNTER](#) ⇒ [PULSE INPUT 1+2+3+4](#) actual value exceeds this setpoint value, the relay assigned in the [TOTALIZED PULSES RELAY](#) will energize. If the “Alarm” relay is assigned, a **TOTALIZED PULSES ALARM** message will also be displayed. The units in this setpoint are determined by the [S2 SYSTEM SETUP](#) ⇒ [PULSE INPUT](#) ⇒ [PULSE INPUT UNITS](#) setpoint.
- **TOTALIZED PULSES DELAY:** This setpoint can be used to allow a time delay before the assigned relay will energize after the [TOTAL PULSES LEVEL](#) has been equaled or exceeded.

## Time

PATH: [SETPOINTS](#) ⇒ [S4 ALARMS/CONTROL](#) ⇒ [TIME](#)

<b>■ TIME</b>	[▷]		<b>TIME</b> <b>RELAY: OFF</b>	<i>Range: Alarm, Aux1, Aux2, Aux3, Off</i>
	MESSAGE		<b>PICKUP TIME ≥</b> <b>12:00:00 am</b>	<i>Range: hh:mm:ss am/pm</i>
	MESSAGE		<b>DROPOUT TIME ≥</b> <b>12:00:00 pm</b>	<i>Range: hh:mm:ss am/pm</i>

The time function is useful where a general purpose time alarm is required or a process is required to start and stop each day at the specified time.

- **TIME RELAY:** This setpoint can be used to give an indication (alarm or control) if the programmed [PICKUP TIME](#) is equaled or exceeded. Set to “Off” if the feature is not required. Selecting “Alarm” activates the alarm relay and displays an alarm message whenever the PQM II clock time equals or exceeds the set [PICKUP TIME](#). Selecting “Aux1”, “Aux2”, or “Aux3” activates the appropriate auxiliary relay but no message is displayed. The “Aux1”, “Aux2”, and “Aux3” selections are intended for process control. The selected relay will de-energize when the PQM II clock time equals or exceeds the [DROPOUT TIME](#) setting.

- PICKUP TIME:** The relay assigned in the **TIME RELAY** setpoint energizes when the PQM II clock time equals or exceeds the time specified in this setpoint. Follow the example below to set the **PICKUP TIME**.

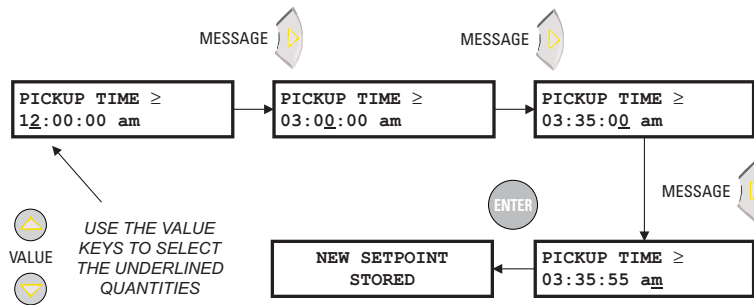

- DROPOUT TIME:** The relay assigned in the **TIME RELAY** setpoint de-energizes when the PQM II clock time equals or exceeds the time specified in this setpoint. Follow the example above to set the **DROPOUT TIME**.

### Miscellaneous Alarms

PATH: SETPOINTS ⇄ S4 ALARMS/CONTROL ⇄ MISCELLANEOUS

<b>MISCELLANEOUS</b> [▷]		<b>SERIAL COM1 FAILURE</b> <b>ALARM DELAY: OFF s</b>	<i>Range: 5 to 60 s in steps of 1 or OFF</i>
	MESSAGE	<b>SERIAL COM2 FAILURE</b> <b>ALARM DELAY: OFF s</b>	<i>Range: 5 to 60 s in steps of 1 or OFF</i>
	MESSAGE	<b>CLOCK NOT SET ALARM:</b> <b>ON</b>	<i>Range: Off, On</i>
	MESSAGE	<b>DATA LOG 1 MEMORY</b> <b>FULL LEVEL: OFF %</b>	<i>Range: 50 to 100% in steps of 1 or OFF</i>
	MESSAGE	<b>DATA LOG 2 MEMORY</b> <b>FULL LEVEL: OFF %</b>	<i>Range: 50 to 100% in steps of 1 or OFF</i>

- SERIAL COM1(2) FAILURE ALARM DELAY:** If loss of communications to the external master is required to activate the alarm relay, select a time delay in the range of 5 to 60 seconds. In this case, an absence of communication polling on the RS485 communication port for the selected time delay will generate the alarm condition. Disable this alarm if communications is not used or is not considered critical. This alarm is not available on the front RS232 port.
- CLOCK NOT SET ALARM:** The software clock in the PQM II will remain running for a period of approximately thirty days after power has been removed from the PQM II power supply inputs. Selecting “On” for this setpoint causes a Clock Not Set Alarm to occur at power-up for power losses greater than thirty days. Once the alarm occurs, the **S1 PQM II SETUP** ⇄ **CLOCK** ⇄ **SET TIME & DATE** setting must be stored to reset the alarm.
- DATA LOG 1(2) MEMORY FULL LEVEL:** These messages can be used to configure alarms to indicate that the Data Logger memory is almost full. Separate alarms are provided for each log. When the log memory reaches the level programmed in this message a Data Log 1(2) Alarm will occur.

# S5 Testing

## Test Relays and LEDs

PATH: SETPOINTS ⇌ S5 TESTING ⇌ TEST RELAYS & LEDS

■ TEST RELAYS & LEDS [▷]		OPERATION TEST: NORMAL MODE
--------------------------	--	--------------------------------

To verify correct operation of output relay wiring, each output relay and status indicator can be manually forced on or off via the keypad or serial port.

While the OPERATION TEST setpoint is displayed, use the VALUE keys to scroll to the desired output relay and/or status indicator to be tested. As long as the test message remains displayed the respective output relay and/or status indicator will be forced to remain energized. As soon as a new message is selected, the respective output relay and/or status indicator return to normal operation.

## Current/Voltage

PATH: SETPOINTS ⇌ S5 TESTING ⇌ CURRENT/VOLTAGE SIMULATION

■ CURRENT/ VOLTAGE SIMULATION [▷]		SIMULATION: OFF	Range: Off, On
MESSAGE		SIMULATION ENABLED FOR: 15 min	Range: 5 to 300 min. in steps of 5 or UNLIMITED
MESSAGE		PHASE A CURRENT: 0 A	Range: 0 to 10000 A in steps of 1
MESSAGE		PHASE B CURRENT: 0 A	Range: 0 to 10000 A in steps of 1
MESSAGE		PHASE C CURRENT: 0 A	Range: 0 to 10000 A in steps of 1
MESSAGE		NEUTRAL CURRENT: 0 A	Range: 0 to 10000 A in steps of 1
MESSAGE		Vax VOLTAGE: 0 V	Range: 0 to 65000 V in steps of 1
MESSAGE		Vbx VOLTAGE: 0 V	Range: 0 to 65000 V in steps of 1
MESSAGE		Vcx VOLTAGE: 0 V	Range: 0 to 65000 V in steps of 1
MESSAGE		PHASE ANGLE: 0 DEGREES	Range: 0 to 359 degrees in steps of 1

Simulated currents and voltages can be forced instead of using actual currents or voltages. This allows for verification of current and voltage related functions.

- **SIMULATION:** Enter “On” to switch from actual currents and voltages to the programmed simulated values. Return to “Off” after simulation is complete.

- **SIMULATION ENABLED FOR:** Select the desired length of time to enable simulation. When the programmed time has elapsed, current and voltage simulation will turn off. If “Unlimited” is selected, simulated currents and voltages will be used until simulation is turned off via the **SIMULATION** setpoint or via the serial port or until control power is removed from the PQM II.
- **PHASE A/B/C/NEUTRAL CURRENT:** Enter the desired phase and neutral currents for simulation.
- **Vax/Vbx/Vcx VOLTAGE:** Enter the desired voltages for simulation. The voltages entered will be line or phase quantities depending upon the VT wiring type selected with the **S2 SYSTEM SETUP** ⇒ **CURRENT/VOLTAGE CONFIGURATION** ⇒ **VT WIRING** setpoint.
- **PHASE ANGLE:** This setpoint represents the phase shift from a unity power factor. Enter the desired phase angle between the current and voltage. The angle between the individual currents and voltages is fixed at 120°.

## Analog Outputs

PATH: SETPOINTS ⇒ S5 TESTING ⇒ ANALOG OUTPUTS SIMULATION

■ <b>ANALOG OUTPUTS SIMULATION</b> [▷]			<b>SIMULATION:</b> OFF	Range: Off, On
MESSAGE			<b>SIMULATION ENABLED FOR:</b> 15 min	Range: 5 to 300 min. in steps of 5 or UNLIMITED
MESSAGE			<b>ANALOG OUTPUT 1:</b> OFF %	Range: 0.0 to 120.0% in steps of 0.1
MESSAGE			<b>ANALOG OUTPUT 2:</b> OFF %	Range: 0.0 to 120.0% in steps of 0.1
MESSAGE			<b>ANALOG OUTPUT 3:</b> OFF %	Range: 0.0 to 120.0% in steps of 0.1
MESSAGE			<b>ANALOG OUTPUT 4:</b> OFF %	Range: 0.0 to 120.0% in steps of 0.1

- **SIMULATION:** Enter “On” to switch from actual analog outputs to the programmed simulated values. Set this setpoint “Off” after simulation is complete.
- **SIMULATION ENABLED FOR:** Select the desired length of time that simulation will be enabled. When the programmed time has elapsed, analog output simulation will turn off. If unlimited is selected, simulated analog outputs will be used until simulation is turned off via the **SIMULATION** setpoint or via the serial port or until control power is removed from the PQM II.
- **ANALOG OUTPUT 1(4):** Enter the percentage of analog output to be simulated. The output is 0 to 1 or 4 to 20 mA, depending upon the installed option.

For example, alter the setpoints below:

S5 TESTING ⇒ ANALOG OUTPUTS SIMULATION ⇒ ANALOG OUTPUT 1: “50.0%”

S5 TESTING ⇒ ANALOG OUTPUTS SIMULATION ⇒ SIMULATION: “On”

The output current level on Analog Output 1 will be 12 mA (4 to 20mA) or 0.5 mA (0 to 1mA).

**Simulated values for Analog outputs may only be entered while SIMULATION mode is set to “On”.**

## Analog Input

PATH: SETPOINTS ↓ S5 TESTING ↓ ANALOG INPUTS SIMULATION

<b>ANALOG INPUT SIMULATION</b> [▷]		<b>SIMULATION:</b> OFF	<i>Range: Off, On</i>
	MESSAGE	<b>SIMULATION ENABLED FOR:</b> 15 min	<i>Range: 5 to 300 min. in steps of 5 or UNLIMITED</i>
	MESSAGE	<b>ANALOG INPUT:</b> OFF mA	<i>Range: 4.0 to 20.0 mA in steps of 0.1</i>

- **SIMULATION:** Enter “On” to switch from an actual analog input to the programmed simulated value. Set this setpoint “Off” after simulation is complete.
- **SIMULATION ENABLED FOR:** Select the desired length of time to run simulation. When the programmed time has elapsed, analog input simulation will end. If “Unlimited” is selected, the simulated analog input will be used until simulation is turned off via the **SIMULATION** setpoint or via the serial port or until control power is removed from the PQM II.
- **ANALOG INPUT:** Enter an analog input current in the range of 4 to 20 mA to be simulated.

## Switch Inputs

PATH: SETPOINTS ⇄ ↓ S5 TESTING ⇄ ↓ SWITCH INPUTS SIMULATION

<b>SWITCH INPUTS SIMULATION</b> [▷]		<b>SIMULATION:</b> Off	<i>Range: Off, On</i>
	MESSAGE	<b>SIMULATION ENABLED FOR:</b> 15 min.	<i>Range: 5 to 300 min. in steps of 5 or UNLIMITED</i>
	MESSAGE	<b>SWITCH INPUT A:</b> Open	<i>Range: Open, Closed</i>
	MESSAGE	<b>SWITCH INPUT B:</b> Open	<i>Range: Open, Closed</i>
	MESSAGE	<b>SWITCH INPUT C:</b> Open	<i>Range: Open, Closed</i>
	MESSAGE	<b>SWITCH INPUT D:</b> Open	<i>Range: Open, Closed</i>

- **SIMULATION:** Enter “On” to switch from actual switch inputs to the programmed simulated switches. Set this setpoint “Off” after simulation is complete.
- **SIMULATION ENABLED FOR:** Select the desired length of time that simulation will be enabled. When the programmed time has elapsed, switch input simulation will turn off. If “Unlimited” is selected, the simulated switch inputs will be used until simulation is turned off via the **SIMULATION** setpoint or via the serial port or until control power is removed from the PQM II.
- **SWITCH INPUT A(D):** Enter the switch input status (open or closed) to be simulated.

## Factory Use Only

PATH: SETPOINTS ⇨⇩ S5 TESTING ⇨⇩ FACTORY USE ONLY

■ **FACTORY USE ONLY** [▷]



**SERVICE PASSCODE :**  
0

*Range:N/A*

These messages are for access by GE Vernova personnel only for testing and service.

# PQM II Power Quality Meter

## Chapter 6: Monitoring





















---

### Viewing Actual Values

#### Description

Any measured value can be displayed on demand using the MENU and MESSAGE keys. Press the MENU key to select the actual values, then the MESSAGE RIGHT key to select the beginning of a new page of monitored values. These are grouped as follows: A1 Metering, A2 Status, A3 Power Analysis, and A4 Product Info. Use the MESSAGE keys to move between actual value messages. A detailed description of each displayed message in these groups is given in the sections that follow.

## Actual Values Menu

<b>■ ACTUAL VALUES</b> [▷] <b>A1 METERING</b>		<b>■ CURRENT</b> [▷]	See page 6-3.
MESSAGE		<b>■ VOLTAGE</b> [▷]	See page 6-5.
MESSAGE		<b>■ PHASORS</b> [▷]	See page 6-7.
MESSAGE		<b>■ POWER</b> [▷]	See page 6-7.
MESSAGE		<b>■ ENERGY</b> [▷]	See page 6-11.
MESSAGE		<b>■ DEMAND</b> [▷]	See page 6-13.
MESSAGE		<b>■ FREQUENCY</b> [▷]	See page 6-14.
MESSAGE		<b>■ PULSE INPUT COUNTERS</b> [▷]	See page 6-15.
MESSAGE		<b>■ ANALOG INPUT</b> [▷]	See page 6-16.
MESSAGE		<b>■ END OF PAGE A1</b> [▷]	
MESSAGE			
<b>■ ACTUAL VALUES</b> [▷] <b>A2 STATUS</b>		<b>■ ALARMS</b> [▷]	See page 6-17.
MESSAGE		<b>■ SWITCHES</b> [▷]	See page 6-19.
MESSAGE		<b>■ CLOCK</b> [▷]	See page 6-20.
MESSAGE		<b>■ PROGRAMMABLE MESSAGE</b> [▷]	See page 6-20.
MESSAGE		<b>■ END OF PAGE A2</b> [▷]	
MESSAGE			
<b>■ ACTUAL VALUES</b> [▷] <b>A3 POWER ANALYSIS</b>		<b>■ POWER QUALITY VALUES</b> [▷]	See page 6-20.
MESSAGE		<b>■ TOTAL HARMONIC DISTORTION</b> [▷]	See page 6-21.
MESSAGE		<b>■ DATA LOGGER</b> [▷]	See page 6-22.



MESSAGE		■ <b>EVENT RECORDER</b> [▷]	See page 6-23.
MESSAGE		■ <b>VOLTAGE DIST. RECORDER</b> [▷]	See page 6-27.
MESSAGE		■ <b>END OF PAGE A3</b> [▷]	
MESSAGE		■ <b>ACTUAL VALUES A4 PRODUCT INFO</b> [▷]	
		■ <b>SOFTWARE VERSIONS</b> [▷]	See page 6-28.
		■ <b>MODEL INFORMATION</b> [▷]	See page 6-28.
MESSAGE		■ <b>END OF PAGE A4</b> [▷]	

## A1 Metering

### Current Metering

PATH: ACTUAL VALUES ⇨ A1 METERING ⇨ ↓ CURRENT

■ <b>CURRENT</b> [▷]		A = 100      B = 100 C = 100      AMPS
MESSAGE		Iavg =      100 AMPS Vavg =      120 V L-N
MESSAGE		NEUTRAL CURRENT = 0 AMPS
MESSAGE		CURRENT UNBALANCE = 0.0%
MESSAGE		Ia MIN =    100 AMPS 12:00:00am 01/01/95
MESSAGE		Ib MIN =    100 AMPS 12:00:00am 01/01/95
MESSAGE		Ic MIN =    100 AMPS 12:00:00am 01/01/95
MESSAGE		In MIN =    100 AMPS 12:00:00am 01/01/95
MESSAGE		I U/B MIN = 0.0% 12:00:00am 01/01/95
MESSAGE		Ia MAX =    100 AMPS 12:00:00am 01/01/95
MESSAGE		Ib MAX =    100 AMPS 12:00:00am 01/01/95

MESSAGE		Ic MAX = 100 AMPS 12:00:00am 01/01/95
MESSAGE		In MAX = 100 AMPS 12:00:00am 01/01/95
MESSAGE		I U/B MAX = 0.0% 12:00:00am 01/01/95

- A, B, C CURRENT:** Displays the current in each phase corresponding to the A, B, and C phase inputs. Current will be measured correctly only if the **CT PRIMARY** is entered to match the installed CT primary and the CT secondary is wired to match the 1 or 5 A input. If the displayed current does not match the actual current, check this setpoint and wiring.
- Iavg/Vavg:** Displays the average of the three phase currents and three voltages. This line is not visible if the **VT WIRING** setpoint is set to “Single Phase Direct”. L-N is displayed when **VT WIRING** is set to “4 Wire Wye /3 VTs”, “4 Wire Wye Direct”, “4 Wire Wye / 2 VTs”, or “3 Wire Direct”. L-L is displayed when **VT WIRING** is set to “3 Wire Delta / 2 VTs”.
- NEUTRAL CURRENT:** Neutral current can be determined by two methods. One method measures the current via the neutral CT input. The second calculates the neutral current based on the three phase currents; using the instantaneous samples,  $I_a + I_b + I_c = I_n$ . If the sum of the phase currents does not equal 0, the result is the neutral current. When using the CT input, the neutral current reading will be correct only if the CT is wired correctly and the correct neutral CT primary value is entered. Verify neutral current by connecting a clamp-on ammeter around all 3 phases. If the neutral current appears incorrect, check the settings in **S2 SYSTEM SETUP** ⇒ **CURRENT/VOLTAGE CONFIGURATION** and verify the CT wiring.
- CURRENT UNBALANCE:** Displays the percentage of current unbalance. Current unbalance is calculated as:

$$\text{Current Unbalance} = \frac{|I_m - I_{av}|}{|I_{av}|} \times 100\% \tag{EQ 0.1}$$

where:  $I_{av}$  = average phase current =  $(I_a + I_b + I_c) / 3$   
 $I_m$  = current in phase with maximum deviation from  $I_{av}$ .

Even though it is possible to achieve unbalance greater than 100% with the above formula, the PQM II limits unbalance readings to 100%.

















If the average current is below 10% of the **CT PRIMARY** setpoint, the unbalance reading is forced to 0%. This avoids nuisance alarms when the system is lightly loaded. If the simulation currents are being used, the unbalance is never forced to 0%.



- Ia, Ib, Ic, In MIN:** Displays the minimum current magnitudes and the time and date of their occurrence. This information is stored in non-volatile memory and is retained during loss of control power. The **S1 PQM II SETUP** ⇒ **CLEAR DATA** ⇒ **CLEAR MIN/MAX CURRENT VALUES** setpoint clears these values.
- I U/B MIN:** Displays the minimum current unbalance and the time and date of its measurement. This information is stored in non-volatile memory and is retained during loss of control power. The **S1 PQM II SETUP** ⇒ **CLEAR DATA** ⇒ **CLEAR MIN/MAX CURRENT VALUES** setpoint clears this value.
- Ia, Ib, Ic, In MAX:** Displays the maximum current magnitudes and the time and date of their occurrence. This information is stored in non-volatile memory and is retained during loss of control power. The **S1 PQM II SETUP** ⇒ **CLEAR DATA** ⇒ **CLEAR MIN/MAX CURRENT VALUES** setpoint clears these values.

- I U/B MAX:** Displays the maximum current unbalance and the time and date of its measurement. This information is stored in non-volatile memory and is retained during loss of control power. The **S1 PQM II SETUP** ⇒ **CLEAR DATA** ⇒ **CLEAR MIN/MAX CURRENT VALUES** setpoint command clears this value.

## Voltage Metering

PATH: ACTUAL VALUES ⇒ A1 METERING ⇒ VOLTAGE

<div style="border: 1px solid black; padding: 2px;"> <span style="background-color: black; color: white; padding: 2px;">VOLTAGE</span> <span style="float: right;">[▷]</span> </div>			Van = 120    Vbn = 120 Vcn = 120    V
MESSAGE			Iavg =            100 AMPS Vavg =            120 V L-N
MESSAGE			Vab=     0    Vbc=     0 Vca=     0    V
MESSAGE			AVERAGE LINE VOLTAGE =        208 V
MESSAGE			VOLTAGE UNBALANCE = 0.0%
MESSAGE			Van MIN =    100 V 12:00:00am    01/01/95
MESSAGE			Vbn MIN =    100 V 12:00:00am    01/01/95
MESSAGE			Vcn MIN =    100 V 12:00:00am    01/01/95
MESSAGE			Vab MIN =    173 V 12:00:00am    01/01/95
MESSAGE			Vbc MIN =    173 V 12:00:00am    01/01/95
MESSAGE			Vca MIN =    173 V 12:00:00am    01/01/95
MESSAGE			V U/B MIN =    0.0% 12:00:00am    01/01/95
MESSAGE			Van MAX =    140 V 12:00:00am    01/01/95
MESSAGE			Vbn MAX =    140 V 12:00:00am    01/01/95
MESSAGE			Vcn MAX =    140 V 12:00:00am    01/01/95
MESSAGE			Vab MAX =    242 V 12:00:00am    01/01/95
MESSAGE			Vbc MAX =    242 V 12:00:00am    01/01/95

MESSAGE		Vca MAX = 242 V 12:00:00am 01/01/95
MESSAGE		V U/B MAX = 5.1% 12:00:00am 01/01/95

- **Van, Vbn, Vcn:** Displays phase voltages corresponding to the A, B, and C voltage inputs. This voltage will be measured correctly only if the **VT RATIO**, **VT NOMINAL SECONDARY**, and **VOLTAGE WIRING** setpoints match the installed VTs. If the displayed voltage does not match the actual voltage, check the setpoints and wiring. This message appears only if the **VT WIRING** is configured for a wye input.
- **Iavg/Vavg:** Displays the average of the three phase currents/voltages. This value is not visible if the **VT WIRING** setpoint is set to “Single Phase Direct”. L-N is displayed when **VT WIRING** is set to “4 Wire Wye / 3 VTs”, “4 Wire Wye Direct”, “4 Wire Wye / 2 VTs”, or “3 Wire Direct” and L-L is displayed when **VT WIRING** is set to “3 Wire Delta / 2 VTs”.
- **Vab, Vbc, Vca:** Displays line voltages corresponding to the A, B, and C voltage inputs. The measured voltage is correct only if the **VT RATIO**, **VT NOMINAL SECONDARY**, and **VOLTAGE WIRING** setpoints match the installed VTs. If the displayed voltage does not match the actual voltage, check the setpoints and wiring.
- **AVERAGE LINE VOLTAGE:** Displays the average of the three line voltages. This value is not visible if the **VT WIRING** setpoint is set to “Single Phase Direct”.
- **VOLTAGE UNBALANCE:** Displays the percentage voltage unbalance. Voltage unbalance is calculated as shown below. If the **VOLTAGE WIRING** is configured for a wye input, voltage unbalance is calculated using phase quantities. If the **VT WIRING** is configured as a delta input, voltage unbalance is calculated using line voltages.

$$\text{Voltage Unbalance} = \frac{|V_m - V_{avg}|}{V_{avg}} \times 100\% \quad (\text{EQ 0.2})$$

where:  $V_{avg}$  = average phase voltage =  $(V_{an} + V_{bn} + V_{cn}) / 3$  for “Wye” and “3 Wire Direct” connections;  
 = average line voltage =  $(V_{ab} + V_{bc} + V_{ca}) / 3$  for “3 Wire Delta / 2 VTs” connection  
 $V_m$  = voltage in a phase (or line) with maximum deviation from  $V_{avg}$ .

**Even though it is possible to achieve unbalance greater than 100% with the above formula, the PQM II will limit unbalance readings to 100%.**

If the average voltage is below 10% of **VT RATIO** × **VT NOMINAL SECONDARY VOLTAGE** for “3 Wire Delta / 2 VTs”, “4 Wire Wye / 3 VTs”, and “4 Wire Wye / 2 VTs” connections, or below 10% of **VT RATIO** × **NOMINAL DIRECT INPUT VOLTAGE** for “4 Wire Wye/Direct” and “3 Wire Direct” connections, the unbalance reading is forced to 0%. This is implemented to avoid nuisance alarms when the system is lightly loaded. If the simulation voltages are being used, the unbalance is never forced to 0%.

- **Van, Vbn, Vcn MIN/MAX:** Displays the minimum/maximum phase voltage magnitudes and the time and date of their occurrence. This information is stored in non-volatile memory and is retained during loss of control power. The **S1 PQM II SETUP** ⇒ **CLEAR DATA** ⇒ **CLEAR MIN/MAX VOLTAGE VALUES** setpoint clears these values.
- **Vab, Vbc, Vca MIN/MAX:** Displays the minimum/maximum line voltage magnitudes and the time and date of their occurrence. This information is stored in non-volatile memory and is retained during loss of control power. The **S1 PQM II SETUP** ⇒ **CLEAR DATA** ⇒ **CLEAR MIN/MAX VOLTAGE VALUES** setpoint clears these values.
- **V U/B MIN/MAX:** Displays minimum/maximum voltage unbalance and the time and date of its measurement. This information is stored in non-volatile memory

and is retained during loss of control power. This value is cleared with the **S1 PQM II SETUP** ⇒ **CLEAR DATA** ⇒ **CLEAR MIN/MAX VOLTAGE VALUES** setpoint.

## Phasors

PATH: ACTUAL VALUES ⇒ A1 METERING ⇒ **PHASORS**





















<div style="border: 1px solid black; padding: 5px; display: flex; align-items: center;"> <span style="margin-right: 10px;">■ PHASORS</span> <span>[▷]</span> </div>		<b>Va PHASOR:</b> 0V at 0° Lag
	MESSAGE	<b>Vb PHASOR:</b> 0V at 0° Lag
	MESSAGE	<b>Vc PHASOR:</b> 0V at 0° Lag
	MESSAGE	<b>Ia PHASOR:</b> 0A at 0° Lag
	MESSAGE	<b>Ib PHASOR:</b> 0A at 0° Lag
	MESSAGE	<b>Ic PHASOR:</b> 0A at 0° Lag





















- **Va PHASOR:** Displays a phasor representation for the magnitude and angle of Va. Va is used as a reference for all other phasor angles. If there is no voltage present at the PQM II voltage inputs, then Ia will be used as the reference for all other angles. Va is also used as the reference when in Simulation Mode.
- **Vb/Vc PHASOR:** Displays a phasor representation for the magnitude and angle of Vb/Vc. Both **Vb** and **Vc PHASOR** values use the angle of **Va PHASOR** as a reference point. If there is no voltage at the PQM II voltage inputs, **Ia PHASOR** is used as the reference. These setpoints are not displayed when the PQM II is configured for the “3 Wire Delta/2 VTs”, “4 Wire Wye/2 VTs”, or “Single Phase Direct” connections.
- **Ia PHASOR:** A phasor representation for the magnitude and angle of Ia is displayed here. Ia is used as a reference for all other Phasor angles only when there is no voltage present at the PQM II voltage inputs, otherwise, Va is used as the reference.
- **Ib/Ic PHASOR:** A phasor representation for the magnitude and angle of Ib/Ic is displayed here. The Ib and Ic currents use the angle of Va as a reference point. If there is no voltage at the PQM II voltage inputs, Ia is used as the reference. These setpoints are not displayed when the PQM II is configured for “Single Phase Direct” connection.







## Power Metering

PATH: ACTUAL VALUES ⇒ A1 METERING ⇒ **POWER**

<div style="border: 1px solid black; padding: 5px; display: flex; align-items: center;"> <span style="margin-right: 10px;">■ POWER</span> <span>[▷]</span> </div>		<b>THREE PHASE REAL</b> POWER = 1000 kW
	MESSAGE	<b>THREE PHASE REACTIVE</b> POWER = 120 kvar
	MESSAGE	<b>THREE PHASE APPARENT</b> POWER = 1007 kVA

MESSAGE		THREE PHASE POWER FACTOR = 0.99 Lag
MESSAGE		PHASE A REAL POWER = 1000 kW
MESSAGE		PHASE A REACTIVE POWER = 120 kvar
MESSAGE		PHASE A APPARENT POWER = 1007 kVA
MESSAGE		PHASE A POWER FACTOR = 0.99 Lag
MESSAGE		PHASE B REAL POWER = 1000 kW
MESSAGE		PHASE B REACTIVE POWER = 120 kvar
MESSAGE		PHASE B APPARENT POWER = 1007 kVA
MESSAGE		PHASE B POWER FACTOR = 0.99 Lag
MESSAGE		PHASE C REAL POWER = 1000 kW
MESSAGE		PHASE C REACTIVE POWER = 120 kvar
MESSAGE		PHASE C APPARENT POWER = 1007 kVA
MESSAGE		PHASE C POWER FACTOR = 0.99 Lag
MESSAGE		THREE PHASE REAL POWER = 10.00 MW
MESSAGE		THREE PHASE REACTIVE POWER = 1.20 Mvar
MESSAGE		THREE PHASE APPARENT POWER = 10.07 MVA
MESSAGE		3Φ kW MIN = 1000 12:00:00am 01/01/95
MESSAGE		3Φ kvar MIN = 120 12:00:00am 01/01/95
MESSAGE		3Φ kVA MIN = 1007 12:00:00am 01/01/95
MESSAGE		3Φ PF MIN = 0.99 Lag 12:00:00am 01/01/95
MESSAGE		3Φ kW MAX = 1000 12:00:00am 01/01/95

MESSAGE		3Φ kvar MAX = 120 12:00:00am 01/01/95
MESSAGE		3Φ kVA MAX = 1007 12:00:00am 01/01/95
MESSAGE		3Φ PF MAX = 0.99 Lag 12:00:00am 01/01/95
MESSAGE		AΦ kW MIN = 1000 12:00:00am 01/01/95
MESSAGE		AΦ kvar MIN = 120 12:00:00am 01/01/95
MESSAGE		AΦ kVA MIN = 1007 12:00:00am 01/01/95
MESSAGE		AΦ PF MIN = 0.99 Lag 12:00:00am 01/01/95
MESSAGE		AΦ kW MAX = 1000 12:00:00am 01/01/95
MESSAGE		AΦ kvar MAX = 120 12:00:00am 01/01/95
MESSAGE		AΦ kVA MAX = 1007 12:00:00am 01/01/95
MESSAGE		AΦ PF MAX = 0.99 Lag 12:00:00am 01/01/95
MESSAGE		BΦ kW MIN = 1000 12:00:00am 01/01/95
MESSAGE		BΦ kvar MIN = 120 12:00:00am 01/01/95
MESSAGE		BΦ kVA MIN = 1007 12:00:00am 01/01/95
MESSAGE		BΦ PF MIN = 0.99 Lag 12:00:00am 01/01/95
MESSAGE		BΦ kW MAX = 1000 12:00:00am 01/01/95
MESSAGE		BΦ kvar MAX = 120 12:00:00am 01/01/95
MESSAGE		BΦ kVA MAX = 1007 12:00:00am 01/01/95
MESSAGE		BΦ PF MAX = 0.99 Lag 12:00:00am 01/01/95
MESSAGE		CΦ kW MIN = 1000 12:00:00am 01/01/95

MESSAGE		CΦ kvar MIN = 120 12:00:00am 01/01/95
MESSAGE		CΦ kVA MIN = 1007 12:00:00am 01/01/95
MESSAGE		CΦ PF MIN = 0.99 Lag 12:00:00am 01/01/95
MESSAGE		CΦ kW MAX = 1000 12:00:00am 01/01/95
MESSAGE		CΦ kvar MAX = 120 12:00:00am 01/01/95
MESSAGE		CΦ kVA MAX = 1007 12:00:00am 01/01/95
MESSAGE		CΦ PF MAX = 0.99 Lag 12:00:00am 01/01/95

Power metering actual values are displayed in this page. The [S1 PQM II SETUP](#) ⇨ [CLEAR DATA](#) ⇨ [CLEAR MIN/MAX POWER VALUES](#) setpoint can be used to clear the minimum and maximum values. *FIGURE 6–1: Power Measurement Conventions* for the convention used to describe power direction.

- **THREE PHASE/A/B/C REAL POWER:** The total RMS three phase real power as well as individual phase A/B/C real power is displayed. The phase A/B/C real power messages are displayed only for a “Wye” or “3 Wire Direct” connections. The PQM II shows direction of flow by displaying the signed value of kW.
- **THREE PHASE/A/B/C REACTIVE POWER:** The total RMS three phase reactive power as well as the individual phase A/B/C reactive power is displayed. The phase A/B/C reactive power messages will be displayed only for a “Wye” or “3 Wire Direct” connected system. The PQM II shows direction of flow by displaying the signed value of kvar.
- **THREE PHASE/A/B/C APPARENT POWER:** The total RMS three phase apparent power as well as the individual phase A/B/C apparent power is displayed. The phase A/B/C apparent power messages will be displayed only for a “Wye” or “3 Wire Direct” connected system.
- **THREE PHASE/A/B/C POWER FACTOR:** The three phase true power factor as well as the individual phase A/B/C true power factors is displayed in these messages. The phase A/B/C true power factor messages will be displayed only for a “Wye” or “3 Wire Direct” connected system.
- **3Φ/AΦ/BΦ/CΦ kW MIN/MAX:** The minimum/maximum three phase real power as well as the minimum/maximum individual phase A/B/C real power is displayed, along with the time and date of their measurement. This information is stored in non-volatile memory and will be retained during a loss of control power. The phase A/B/C minimum/maximum real power messages will be displayed only for a “Wye” connected system.
- **3Φ/AΦ/BΦ/CΦ kvar MIN/MAX:** The minimum/maximum three phase reactive power as well as the minimum/maximum individual phase A/B/C reactive power is displayed, along with the time and date of their measurement. This information is stored in non-volatile memory and will be retained during a loss of control power. The phase A/B/C minimum/maximum reactive power messages will be displayed only for a “Wye” connected system.

- 3Φ/AΦ/BΦ/CΦ kVA MIN/MAX:** The minimum/maximum three phase apparent power as well as the minimum/maximum individual phase A/B/C apparent power is displayed, along with the time and date of their measurement. This information is stored in non-volatile memory and will be retained during a loss of control power. The phase A/B/C minimum/maximum apparent power messages will be displayed only for a “Wye” connected system.
- 3Φ/AΦ/BΦ/CΦ PF MIN/MAX:** The minimum/maximum three phase lead or lag power factor as well as the minimum/maximum lead or lag individual phase A/B/C power factor is displayed, along with the time and date of their measurement. This information is stored in non-volatile memory and will be retained during a loss of control power. The phase A/B/C minimum/maximum lead or lag power factor messages will be displayed only for a “Wye” connected system.

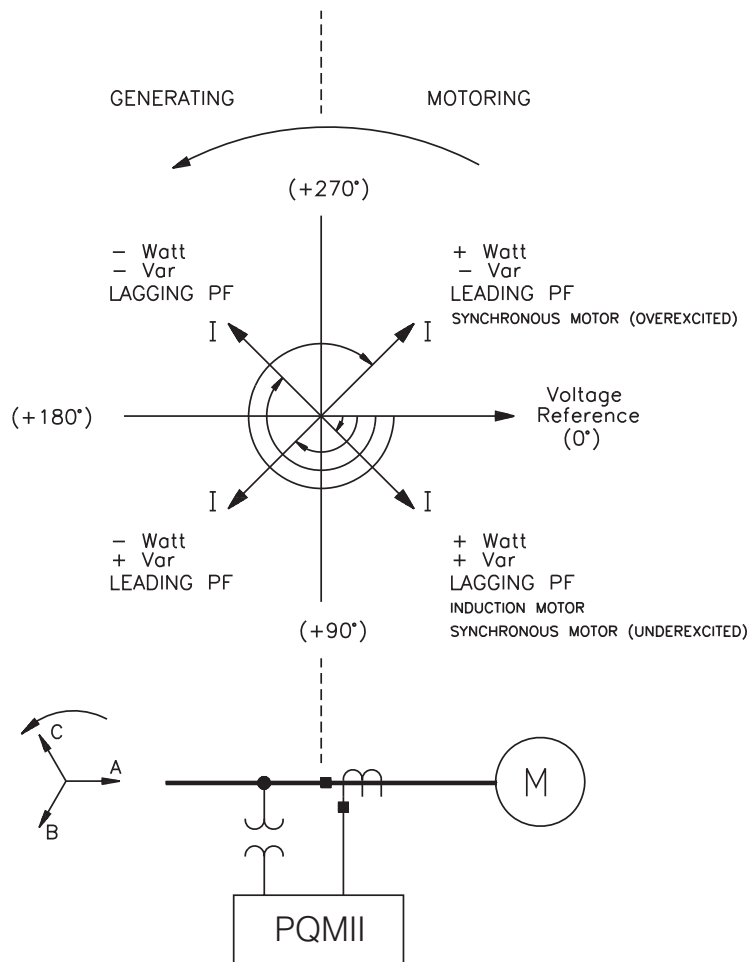
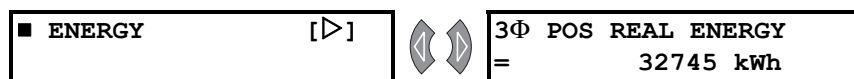















FIGURE 6-1: Power Measurement Conventions

## Energy Metering

PATH: ACTUAL VALUES ⇒ A1 METERING ⇔ ENERGY



MESSAGE		<b>3Φ NEG REAL ENERGY</b> = 32745 kWh
MESSAGE		<b>3Φ POS REACT ENERGY</b> = 32745 kvarh
MESSAGE		<b>3Φ NEG REACT ENERGY</b> = 32745 kvarh
MESSAGE		<b>3Φ APPARENT ENERGY</b> = 32745 kVAh
MESSAGE		<b>REAL ENERGY LAST 24h</b> = 1245 kWh
MESSAGE		<b>REAL ENERGY COST =</b> \$12575.34
MESSAGE		<b>REAL ENERGY COST =</b> \$125.01 / DAY
MESSAGE		<b>TARIFF PERIOD 1 COST</b> \$0.00
MESSAGE		<b>TARIFF PERIOD 2 COST</b> \$0.00
MESSAGE		<b>TARIFF PERIOD 3 COST</b> \$0.00
MESSAGE		<b>TARIFF PERIOD 1 NET ENERGY:</b> 0 kWh
MESSAGE		<b>TARIFF PERIOD 2 NET ENERGY:</b> 0 kWh
MESSAGE		<b>TARIFF PERIOD 3 NET ENERGY:</b> 0 kWh
MESSAGE		<b>TIME OF LAST RESET:</b> 12:00:00am 01/01/95

Energy metering actual values are displayed here. The [S1 PQM II SETUP](#) ⇒ [CLEAR DATA](#) ⇒ [CLEAR ENERGY VALUES](#) setpoint clears these values. The displayed energy values roll over to “0” once the value “4294967295” (FFFFFFFFh) has been reached.











- **3Φ POS/NEG REAL ENERGY:** These messages display the positive/negative watthours (in kWh) since the [TIME OF LAST RESET](#) date. Real power in the positive direction add to the [3Φ POS REAL ENERGY](#) value, whereas real power in the negative direction adds to the [3Φ NEG REAL ENERGY](#) value.
- **3Φ POS/NEG REACT ENERGY:** These messages display the positive/negative varhours (in kvarh) since the [TIME OF LAST RESET](#) date. Reactive power in the positive direction add to the [3Φ POS REACT ENERGY](#) value, whereas reactive power in the negative direction adds to the [3Φ NEG REACT ENERGY](#) value.
- **3Φ APPARENT ENERGY:** This message displays the accumulated VAhours (in kVAh) since the [TIME OF LAST RESET](#) date.
- **REAL ENERGY LAST 24h:** This message displays the accumulated real energy (in kWh) over the last 24-hour period. The 24-hour period used by the PQM II is started when control power is applied. The PQM II updates this value every hour



based on the previous 24-hour period. This information will be lost if control power to the PQM II is removed.

- **REAL ENERGY COST:** This message displays the total cost for the real energy accumulated since the **TIME OF LAST RESET** date.
- **REAL ENERGY COST PER DAY:** Displays the average cost of real energy per day from time of last reset to the present. The cost per kWh is entered in the **S1 PQM II SETUP** ⇒ **↓ CALCULATION PARAMETERS** ⇒ **↓ ENERGY COST PER KWH** setpoint.
- **TARIFF PERIOD 1(3) COST:** These messages display the cost accrued for the three user-definable tariff periods. The start time and cost per kWh for these tariff periods are entered with the **S1 PQM II SETUP** ⇒ **↓ CALCULATION PARAMETERS** ⇒ **↓ TARIFF PERIOD 1(3) START TIME** and the **S1 PQM II SETUP** ⇒ **↓ CALCULATION PARAMETERS** ⇒ **↓ TARIFF PERIOD 1(3) COST PER KWH** setpoints, respectively.
- **TARIFF PERIOD 1(3) NET ENERGY:** These messages display the net energy for the three user-definable tariff periods. The start time and cost per kWh for these tariff periods are entered with the **S1 PQM II SETUP** ⇒ **↓ CALCULATION PARAMETERS** ⇒ **↓ TARIFF PERIOD 1(3) START TIME** and the **S1 PQM II SETUP** ⇒ **↓ CALCULATION PARAMETERS** ⇒ **↓ TARIFF PERIOD 1(3) COST PER KWH** setpoints, respectively.
- **TIME OF LAST RESET:** This message displays the time and date when the energy parameters were last cleared through the **S1 PQM II SETUP** ⇒ **↓ CLEAR DATA** ⇒ **↓ CLEAR ENERGY VALUES** setpoint.

## Demand Metering

PATH: ACTUAL VALUES ⇒ A1 METERING ⇒ **↓ DEMAND**

<div style="border: 1px solid black; padding: 2px;"> <span style="background-color: black; color: white; padding: 0 5px;">■</span> DEMAND                 </div> [▶]		<b>PHASE A CURRENT</b> DEMAND = 125 A
		<b>PHASE B CURRENT</b> DEMAND = 125 A
		<b>PHASE C CURRENT</b> DEMAND = 125 A
		<b>NEUTRAL CURRENT</b> DEMAND = 125 A
		<b>3Φ REAL POWER</b> DEMAND = 1000 kW
		<b>3Φ REACTIVE POWER</b> DEMAND = 25 kvar
		<b>3Φ APPARENT POWER</b> DEMAND = 1007 kVA
		<b>Ia MAX DMD = 560 A</b> 12:00:00am 01/01/95
		<b>Ib MAX DMD = 560 A</b> 12:00:00am 01/01/95
		<b>Ic MAX DMD = 560 A</b> 12:00:00am 01/01/95
	<b>In MAX DMD = 560 A</b> 12:00:00am 01/01/95	



MESSAGE		<b>3Φ kW MAX = 1000</b> 12:00:00am 01/01/95
MESSAGE		<b>3Φ kvar MAX = 25</b> 12:00:00am 01/01/95
MESSAGE		<b>3Φ kVA MAX = 1200</b> 12:00:00am 01/01/95

Demand metering actual values are displayed in this page. The [S1 PQM II SETUP](#) ⇒ [CLEAR DATA](#) ⇒ [CLEAR MAX DEMAND VALUES](#) setpoint can be used to clear the maximum demand values shown here.

- **PHASE A/B/C/NEUTRAL DEMAND:** This message displays the phase A/B/C/N current demand (in amps) over the most recent time interval.
- **3Φ REAL POWER DEMAND:** This message displays the 3 phase real power demand (in kW) over the most recent time interval.
- **3Φ REACTIVE POWER DEMAND:** This message displays the 3 phase reactive power demand (in kvar) over the most recent time interval.
- **3Φ APPARENT POWER DEMAND:** This message displays the 3 phase apparent power demand (in kVA) over the most recent time interval.
- **Ia/Ib/Ic/In MAX DMD:** These messages display the maximum phase A/B/C/N current demand (in amps) and the time and date when this occurred.
- **3Φ kW MAX:** This message displays the maximum three-phase real power demand (in kW) and the time and date when this occurred.
- **3Φ kvar MAX:** This message displays the maximum three-phase reactive power demand (in kvar) and the time and date when this occurred.
- **3Φ kVA MAX:** This message displays the maximum three-phase apparent power demand (in kVA) and the time and date when this occurred.

## Frequency Metering

PATH: ACTUAL VALUES ⇒ A1 METERING ⇒ [FREQUENCY](#)







■ <b>FREQUENCY</b>	[▶]		<b>FREQUENCY = 60.00 Hz</b>
MESSAGE			<b>FREQ MIN = 59.98 Hz</b> 12:00:00am 01/01/95
MESSAGE			<b>FREQ MAX = 59.98 Hz</b> 12:00:00am 01/01/95

Frequency metering actual values are displayed in this page. The [S1 PQM II SETUP](#) ⇒ [CLEAR DATA](#) ⇒ [CLEAR MIN/MAX FREQUENCY VALUES](#) setpoint can be used to clear the minimum and maximum frequency values shown here.

- **FREQUENCY:** This message displays the frequency (in Hz). Frequency is calculated from the phase A-N voltage (when setpoint [S2 SYSTEM SETUP](#) ⇒ [CURRENT/VOLTAGE CONFIGURATION](#) ⇒ [VT WIRING](#) is “Wye”) or from phase A-B voltage (when setpoint [VT WIRING](#) is “Delta”). A value of “0.00” is shown if there is insufficient voltage applied to the PQM II’s terminals (less than 30 V on phase A).
- **FREQ MIN:** This message displays the minimum frequency measured as well as the time and date at which the minimum frequency occurred.
- **FREQ MAX:** This message displays the maximum frequency measured as well as the time and date at which the maximum frequency occurred.

## Pulse Input Counters

PATH: ACTUAL VALUES ⇒ A1 METERING ⇒ ↓ PULSE INPUT COUNTERS

<div style="border: 1px solid black; padding: 2px;">           ■ PULSE INPUT COUNTERS [▷]         </div>		<div style="border: 1px solid black; padding: 2px;">             PULSE INPUT 1 = 0 Units           </div>
MESSAGE		<div style="border: 1px solid black; padding: 2px;">             PULSE INPUT 2 = 0 Units           </div>
MESSAGE		<div style="border: 1px solid black; padding: 2px;">             PULSE INPUT 3 = 0 Units           </div>
MESSAGE		<div style="border: 1px solid black; padding: 2px;">             PULSE INPUT 4 = 0 Units           </div>
MESSAGE		<div style="border: 1px solid black; padding: 2px;">             PULSE INPUT 1+2+3+4 = 0 Units           </div>
MESSAGE		<div style="border: 1px solid black; padding: 2px;">             TIME OF LAST RESET: 12:00:00am 01/01/95           </div>

- PULSE INPUT 1(4):** These messages display the accumulated value based on total number of pulses counted since the last reset. One switch input pulse is equal to the value assigned in the [S2 SYSTEM SETUP](#) ⇒ ↓ [PULSE INPUT](#) ⇒ ↓ [PULSE INPUT 1\(4\) VALUE](#) setpoint. The units shown after the value are as defined in the [PULSE INPUT UNITS](#) setpoint in the same menu. The displayed value rolls over to “0” once the value “4294967295” (FFFFFFFFh) has been reached. To use this feature, the “C” (control) option must be installed and one of the PQM II switch inputs must be assigned to “Pulse Input 1(4)” function. The switch input will then count the number of closures or openings depending upon how the switch is configured; see *Switch Inputs* on page 5–21 for details. The minimum timing requirements are shown in *FIGURE 6–2: Pulse Input Timing*.
- PULSE IN 1+2+3+4:** The totalized pulse input value is displayed here. The pulse inputs totalized is based on the [S2 SYSTEM SETUP](#) ⇒ ↓ [PULSE INPUT](#) ⇒ ↓ [PULSE INPUT TOTAL](#) setpoint.
- TIME OF LAST RESET:** This message displays the time and date when the pulse input values were last cleared. The [S1 PQM II SETUP](#) ⇒ ↓ [CLEAR DATA](#) ⇒ ↓ [CLEAR PULSE INPUT VALUES](#) setpoint clears the pulse input values.

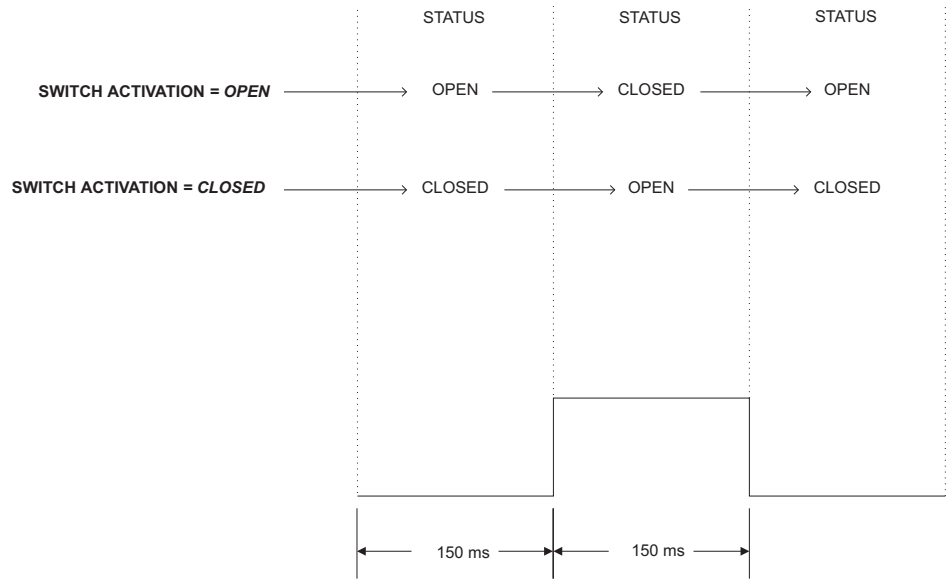

FIGURE 6-2: Pulse Input Timing

## Analog Input

PATH: ACTUAL VALUES ⇌ A1 METERING ⇌ ↓ ANALOG INPUT







































This message displays the measured 4 to 20 mA analog input scaled to the user defined name and units. The analog input can be configured via a switch input and output relay to multiplex two analog input signals. The displayed user defined name and units will change to the corresponding values depending upon which analog input is connected. Refer to *Analog Input* for information regarding user defined names and units as well as analog input multiplexing.

## A2 Status

### Alarms

PATH: ACTUAL VALUES ⇌ A2 STATUS ⇌ ⬇ ALARMS

■ ALARMS	[▷]		PHASE UNDERCURRENT ALARM
MESSAGE			PHASE OVERCURRENT ALARM
MESSAGE			NEUTRAL OVERCURRENT ALARM
MESSAGE			UNDERVOLTAGE ALARM
MESSAGE			OVERVOLTAGE ALARM
MESSAGE			VOLTAGE UNBALANCE ALARM
MESSAGE			CURRENT UNBALANCE ALARM
MESSAGE			PHASE REVERSAL ALARM
MESSAGE			POWER FACTOR LEAD 1 ALARM
MESSAGE			POWER FACTOR LEAD 2 ALARM
MESSAGE			POWER FACTOR LAG 1 ALARM
MESSAGE			POWER FACTOR LAG 2 ALARM
MESSAGE			POSITIVE REAL POWER ALARM
MESSAGE			NEGATIVE REAL POWER ALARM
MESSAGE			POSITIVE REACTIVE POWER ALARM
MESSAGE			NEGATIVE REACTIVE POWER ALARM
MESSAGE			UNDERFREQUENCY ALARM
MESSAGE			OVERFREQUENCY ALARM

MESSAGE		PHASE A CURRENT DEMAND ALARM
MESSAGE		PHASE B CURRENT DEMAND ALARM
MESSAGE		PHASE C CURRENT DEMAND ALARM
MESSAGE		DATA LOG 1 ALARM
MESSAGE		DATA LOG 2 ALARM
MESSAGE		NEUTRAL CURRENT DEMAND ALARM
MESSAGE		POSITIVE REAL POWER DEMAND ALARM
MESSAGE		NEGATIVE REAL POWER DEMAND ALARM
MESSAGE		POSITIVE REACTIVE POWER DEMAND ALARM
MESSAGE		NEGATIVE REACTIVE POWER DEMAND ALARM
MESSAGE		APPARENT POWER DEMAND ALARM
MESSAGE		SWITCH INPUT A ALARM
MESSAGE		SWITCH INPUT B ALARM
MESSAGE		SWITCH INPUT C ALARM
MESSAGE		SWITCH INPUT D ALARM
MESSAGE		SELF-TEST FAILURE ALARM
MESSAGE		SERIAL COM1 FAILURE ALARM
MESSAGE		SERIAL COM2 FAILURE ALARM
MESSAGE		CLOCK NOT SET ALARM

MESSAGE		MAIN ANALOG INPUT ALARM
MESSAGE		ALT ANALOG INPUT ALARM
MESSAGE		CRITICAL SETPOINTS NOT STORED
MESSAGE		CURRENT THD ALARM
MESSAGE		VOLTAGE THD ALARM
MESSAGE		PULSE INPUT 1 ALARM
MESSAGE		PULSE INPUT 2 ALARM
MESSAGE		PULSE INPUT 3 ALARM
MESSAGE		PULSE INPUT 4 ALARM
MESSAGE		TOTALIZED PULSES ALARM
MESSAGE		TIME ALARM

The alarm messages appear only when the alarm threshold has been exceeded for the programmed time. When an alarm is assigned to an output relay, the relay can be set to be unlatched or latched. When the alarm is set as unlatched, it automatically resets when the alarm condition no longer exists. If the alarm is set as latched, a keypad reset or a serial port reset is required.

The **SELF TEST ALARM** occurs if a fault in the PQM II hardware is detected. This alarm is permanently assigned to the alarm output relay and is not user configurable. If this alarm is present, contact the GE Multilin Service Department.

## Switch Status

PATH: ACTUAL VALUES ⇒ A2 STATUS ⇒ SWITCHES

■ SWITCHES	[▷]		SWITCH INPUT A STATE: Closed
MESSAGE			SWITCH INPUT B STATE: Closed
MESSAGE			SWITCH INPUT C STATE: Closed
MESSAGE			SWITCH INPUT D STATE: Closed

To assist in troubleshooting, the state of each switch can be verified using these messages. A separate message displays the status of each input identified by the corresponding name as shown in the wiring diagrams in chapter 2. For a dry contact closure across the corresponding switch terminals the message will read “Closed”.

## Clock

PATH: ACTUAL VALUES ⇒ A2 STATUS ⇒ ⌵ CLOCK

■ CLOCK [▷]		TIME: 12:00:00am DATE: Nov 21 2003
-------------	---	---------------------------------------

The current time and date is displayed in this message. The PQM II uses an internally generated software clock which runs for approximately thirty days after the control power has been removed. For instructions on setting the clock, see *Clock*. The [S4 ALARMS/CONTROL ⇒ ⌵ MISCELLANEOUS ⇒ ⌵ CLOCK NOT SET ALARM](#) alarm occurs if power has been removed for longer than thirty days and the clock value has been lost.

## Programmable Message

PATH: ACTUAL VALUES ⇒ A2 STATUS ⇒ ⌵ PROGRAMMABLE MESSAGE







■ PROGRAMMABLE MESSAGE [▷]		PHONE: 905-294-6222 www.GEmultilin.com
----------------------------	---	---

A 40-character user defined message is displayed. The message is programmed using the keypad or via the serial port using the EnerVista PQM Setup Software. See *Programmable Message* for programming details.

# A3 Power Analysis

## Power Quality

PATH: ACTUAL VALUES ⇒ A3 POWER ANALYSIS ⇒ ⌵ POWER QUALITY VALUES

■ POWER QUALITY VALUES [▷]		Ia CREST FACTOR = 1.233
MESSAGE		Ib CREST FACTOR = 1.008
MESSAGE		Ic CREST FACTOR = 1.000
MESSAGE		Ia THDF = 0.944
MESSAGE		Ib THDF = 0.999
MESSAGE		Ic THDF = 0.988

- la/lb/lc CREST FACTOR:** The crest factor describes how much the load current can vary from a pure sine wave while maintaining the system’s full rating. A completely linear load (pure sine wave) has a crest factor of  $\sqrt{2}$  (1 /0.707), which is the ratio of the peak value of sine wave to its RMS value. Typically, the crest factor can range from  $\sqrt{2}$  to 2.5.
- la/lb/lc THDF:** The Transformer Harmonic Derating Factor (THDF), also known as CBEMA factor, is defined as the crest factor of a pure sine wave ( $\sqrt{2}$ ) divided by the measured crest factor. This method is useful in cases where lower order harmonics are dominant. In a case where higher order harmonics are present, it may be necessary to use a more precise method (K-factor) of calculating the derating factor. This method also does not take into consideration the losses associated with rated eddy current in the transformer. The EnerVista PQM Setup Software provides the K-factor method of calculating the derating factor, which is defined on a per unit basis as follows:

$$K = \sum_{h=1}^{h_{max}} I_h^2 \times h^2 \tag{EQ 6.3}$$

where:  $I_h$  = RMS current at harmonic  $h$ , in per unit of rated RMS load current

## THD

PATH: ACTUAL VALUES ⇒ A3 POWER ANALYSIS ⇒ ↓ TOTAL HARMONIC DISTORTION

<b>■ TOTAL HARMONIC DISTORTION [▷]</b>			<b>PHASE A CURRENT THD=</b> 5.3%
MESSAGE			<b>PHASE B CURRENT THD=</b> 7.8%
MESSAGE			<b>PHASE C CURRENT THD=</b> 4.5%
MESSAGE			<b>NEUTRAL CURRENT THD=</b> 15.4%
MESSAGE			<b>VOLTAGE Van THD=</b> 1.2%
MESSAGE			<b>VOLTAGE Vbn THD=</b> 2.0%
MESSAGE			<b>VOLTAGE Vcn THD=</b> 2.0%
MESSAGE			<b>VOLTAGE Vab THD=</b> 2.0%
MESSAGE			<b>VOLTAGE Vbc THD=</b> 1.1%
MESSAGE			<b>Ia MAX THD = 5.9%</b> 12:00:00am 01/01/95
MESSAGE			<b>Ib MAX THD = 7.8%</b> 12:00:00am 01/01/95
MESSAGE			<b>Ic MAX THD = 4.5%</b> 12:00:00am 01/01/95

MESSAGE		In MAX THD = 15.4% 12:00:00am 01/01/95
MESSAGE		Van MAX THD = 1.2% 12:00:00am 01/01/95
MESSAGE		Vbn MAX THD = 2.0% 12:00:00am 01/01/95
MESSAGE		Vcn MAX THD = 2.0% 12:00:00am 01/01/95
MESSAGE		Vab MAX THD = 2.0% 12:00:00am 01/01/95
MESSAGE		Vbc MAX THD = 1.1% 12:00:00am 01/01/9

- **PHASE A/B/C/N CURRENT THD:** These messages display the calculated total harmonic distortion for each current input.
- **VOLTAGE Van/Vbn/Vcn/Vab/Vbc THD:** These messages display the calculated total harmonic distortion for each voltage input. Phase-to-neutral voltages will appear when the setpoint [S2 SYSTEM SETUP](#) ⇒ [CURRENT/VOLTAGE CONFIGURATION](#) ⇒ [VT WIRING](#) is set as “Wye”. Line-to-line voltages will appear when [VT WIRING](#) is set as “Delta”.
- **Ia/Ib/Ic/In MAX THD:** The maximum total harmonic value for each current input and the time and date which the maximum value occurred are displayed. The [S1 PQM II SETUP \ CLEAR DATA \ CLEAR MAX THD VALUES](#) setpoint clears this value.
- **Van/Vbn/Vcn/Vab/Vbc MAX THD:** These messages display the maximum total harmonic value for each voltage input and the time and date of its occurrence. The setpoint [S1 PQM II SETUP](#) ⇒ [CLEAR DATA](#) ⇒ [CLEAR MAX THD VALUES](#) is used to clear this value. Phase to neutral voltages will appear when the setpoint [S2 SYSTEM SETUP](#) ⇒ [CURRENT/VOLTAGE CONFIGURATION](#) ⇒ [VT WIRING](#) is set to “Wye”. Line to line voltages will appear when [VT WIRING](#) is set to “Delta”.

## Data Logger

PATH: ACTUAL VALUES ⇒ A3 POWER ANALYSIS ⇒ DATA LOGGER



■ DATA LOGGER [▶]		DATA LOG 1: STOPPED: 0% FULL
	MESSAGE	DATA LOG 2: STOPPED: 0% FULL

These message display the current status of Data Loggers 1 and 2. The Data Logger can be set up and run only from the EnerVista PQM Setup Software. See *Data Logger* and *Data Logger Implementation* for additional details on the Data Logger feature.

It is possible to stop the data loggers from the PQM II front panel using the [S2 SYSTEM SETUP](#) ⇒ [DATA LOGGER](#) ⇒ [STOP DATA LOGGER 1\(2\)](#) setpoint.

## Event Recorder

PATH: ACTUAL VALUES ⇒ A3 POWER ANALYSIS ⇒ ↓ EVENT RECORDER

■ EVENT RECORDER [▷]		3 : POWER ON 12:00:00am 01/01/03	
		MESSAGE 	2 : POWER OFF 12:00:00am 01/01/03
		MESSAGE 	1 : CLEAR RECORDS 12:00:00am 01/01/03

The PQM II Event Recorder runs continuously and records the number, cause, time, date, and metering quantities present at the occurrence of each event. This data is stored in non-volatile memory and is not lost when power to the PQM II is removed. The Event Recorder must be enabled in [S1 PQM II SETUP ⇒ ↓ EVENT RECORDER ⇒ ↓ EVENT RECORDER OPERATION](#). The Event Recorder can be cleared in [S1 PQM II SETUP ⇒ ↓ CLEAR DATA ⇒ ↓ CLEAR EVENT RECORD](#). Data for the 150 most recent events is stored. Event data for older events is lost. Note that the event number, cause, time, and date is available in the messages as shown in the following table, but the associated metering data is available only via serial communications.

**The event data stored for POWER OFF events does not reflect values at the time of power-off.**

These messages display the 150 most recent events recorded by the event recorder. The list of possible events and their display on the PQM II is shown below.

**Table 1: List of Possible Events (Sheet 1 of 4)**

Displayed Event Name	Event Description
3Φ +kvar DMD ↑	Positive Reactive Power Demand Alarm/Control Pickup
3Φ +kvar DMD ↓	Positive Reactive Power Demand Alarm/Control Dropout
3Φ +kW DMD ↑	Positive Real Power Demand Alarm/Control Pickup
3Φ +kW DMD ↓	Positive Real Power Demand Alarm/Control Dropout
3Φ kVA DEMAND ↑	Apparent Power Demand Alarm/Control Pickup
3Φ kVA DEMAND ↓	Apparent Power Demand Alarm/Control Dropout
3Φ -kvar DMD ↑	Negative Reactive Power Demand Alarm/Control Pickup
3Φ -kvar DMD ↓	Negative Reactive Power Demand Alarm/Control Dropout
3Φ -kW DMD ↑	Negative Real Power Demand Alarm/Control Pickup
3Φ -kW DMD ↓	Negative Real Power Demand Alarm/Control Dropout

**Table 1: List of Possible Events (Sheet 2 of 4)**

<b>Displayed Event Name</b>	<b>Event Description</b>
ALARM RESET	Latched Alarm/Auxiliary Reset
AN INPUT ALT ↑	Alternate Analog Input Alarm/Control Pickup
AN INPUT ALT ↓	Alternate Analog Input Alarm/Control Dropout
AN INPUT MAIN ↑	Main Analog Input Alarm/Control Pickup
AN INPUT MAIN ↓	Main Analog Input Alarm/Control Dropout
CLOCK NOT SET ↑	Clock Not Set Alarm Pickup
CLOCK NOT SET ↓	Clock Not Set Alarm Dropout
COM1 FAILURE ↑	COM1 Failure Alarm Pickup
COM1 FAILURE ↓	COM1 Failure Alarm Dropout
COM2 FAILURE ↑	COM2 Failure Alarm Pickup
COM2 FAILURE ↓	COM2 Failure Alarm Dropout
CURRENT THD ↑	Current THD Alarm/Control Pickup
CURRENT THD ↓	Current THD Alarm/Control Dropout
CURRENT U/B ↑	Current Unbalance Alarm/Control Pickup
CURRENT U/B ↓	Current Unbalance Alarm/Control Dropout
DATA LOG 1 ↑	Data Log 1 Alarm Pickup
DATA LOG 1 ↓	Data Log 1 Alarm Dropout
DATA LOG 2 ↑	Data Log 2 Alarm Pickup
DATA LOG 2 ↓	Data Log 2 Alarm Dropout
Ia DEMAND ↑	Phase A Current Demand Alarm/Control Pickup
Ia DEMAND ↓	Phase A Current Demand Alarm/Control Dropout
Ib DEMAND ↑	Phase B Current Demand Alarm/Control Pickup
Ib DEMAND ↓	Phase B Current Demand Alarm/Control Dropout
Ic DEMAND ↑	Phase C Current Demand Alarm/Control Pickup
Ic DEMAND ↓	Phase C Current Demand Alarm/Control Dropout
In DEMAND ↑	Neutral Current Demand Alarm/Control Pickup
In DEMAND ↓	Neutral Current Demand Alarm/Control Dropout
NEG kvar ↑	Negative Reactive Power Alarm/Control Pickup
NEG kvar ↓	Negative Reactive Power Alarm/Control Dropout
NEG kW ↑	Negative Real Power Alarm/Control Pickup
NEG kW ↓	Negative Real Power Alarm/Control Dropout

**Table 1: List of Possible Events (Sheet 3 of 4)**

<b>Displayed Event Name</b>	<b>Event Description</b>
NEUTRAL ↑	Neutral Overcurrent Alarm/Control Pickup
NEUTRAL ↓	Neutral Overcurrent Alarm/Control Dropout
OVERCURRENT ↑	Overcurrent Alarm/Control Pickup
OVERCURRENT ↓	Overcurrent Alarm/Control Dropout
OVERFREQUENCY ↑	Overfrequency Alarm/Control Pickup
OVERFREQUENCY ↓	Overfrequency Alarm/Control Dropout
OVERVOLTAGE ↑	Overvoltage Alarm/Control Pickup
OVERVOLTAGE ↓	Overvoltage Alarm/Control Dropout
PARAM NOT SET ↑	Critical Setpoints Not Stored Alarm Pickup
PARAM NOT SET ↓	Critical Setpoints Not Stored Alarm Dropout
PF LAG 1 ↑	Power Factor Lag 1 Alarm/Control Pickup
PF LAG 1 ↓	Power Factor Lag 1 Alarm/Control Dropout
PF LAG 2 ↑	Power Factor Lag 2 Alarm/Control Pickup
PF LAG 2 ↓	Power Factor Lag 2 Alarm/Control Dropout
PF LEAD 1 ↑	Power Factor Lead 1 Alarm/Control Pickup
PF LEAD 1 ↓	Power Factor Lead 1 Alarm/Control Dropout
PF LEAD 2 ↑	Power Factor Lead 2 Alarm/Control Pickup
PF LEAD 2 ↓	Power Factor Lead 2 Alarm/Control Dropout
PHASE REVERSAL↑	Phase Reversal Alarm/Control Pickup
PHASE REVERSAL↓	Phase Reversal Alarm/Control Dropout
POS kvar ↑	Positive Reactive Power Alarm/Control Pickup
POS kvar ↓	Positive Reactive Power Alarm/Control Dropout
POS kW ↑	Positive Real Power Alarm/Control Pickup
POS kW ↓	Positive Real Power Alarm/Control Dropout
POWER OFF	Power Off
POWER ON	Power On
PROGRAM ENABLE	Setpoint Access On
PULSE IN 1 ↑	Pulse Input 1 Alarm/Control Pickup
PULSE IN 1 ↓	Pulse Input 1 Alarm/Control Dropout
PULSE IN 2 ↑	Pulse Input 2 Alarm/Control Pickup
PULSE IN 2 ↓	Pulse Input 2 Alarm/Control Dropout

**Table 1: List of Possible Events (Sheet 4 of 4)**

<b>Displayed Event Name</b>	<b>Event Description</b>
PULSE IN 3 ↑	Pulse Input 3 Alarm/Control Pickup
PULSE IN 3 ↓	Pulse Input 3 Alarm/Control Dropout
PULSE IN 4 ↑	Pulse Input 4 Alarm/Control Pickup
PULSE IN 4 ↓	Pulse Input 4 Alarm/Control Dropout
PULSE TOTAL ↑	Totalized Pulses Alarm/Control Pickup
PULSE TOTAL ↓	Totalized Pulses Alarm/Control Dropout
SELF TEST ↑	Self Test Failure Alarm Pickup
SELF TEST ↓	Self Test Failure Alarm Dropout
SW A ACTIVE ↑	Switch Input A Alarm/Control Pickup
SW A ACTIVE ↓	Switch Input A Alarm/Control Dropout
SW B ACTIVE ↑	Switch Input B Alarm/Control Pickup
SW B ACTIVE ↓	Switch Input B Alarm/Control Dropout
SW C ACTIVE ↑	Switch Input C Alarm/Control Pickup
SW C ACTIVE ↓	Switch Input C Alarm/Control Dropout
SW D ACTIVE ↑	Switch Input D Alarm/Control Pickup
SW D ACTIVE ↓	Switch Input D Alarm/Control Dropout
TIME ↑	Time Alarm/Control Pickup
TIME ↓	Time Alarm/Control Dropout
TRACE TRIG ↑	Trace Memory Triggered
UNDERCURRENT ↑	Undercurrent Alarm/Control Pickup
UNDERCURRENT ↓	Undercurrent Alarm/Control Dropout
UNDERVOLTAGE ↑	Undervoltage Alarm/Control Pickup
UNDERVOLTAGE ↓	Undervoltage Alarm/Control Dropout
UNDRFREQUENCY ↑	Underfrequency Alarm/Control Pickup
UNDRFREQUENCY ↓	Underfrequency Alarm/Control Dropout
VOLTAGE THD ↑	Voltage THD Alarm/Control Pickup
VOLTAGE THD ↓	Voltage THD Alarm/Control Dropout
VOLTAGE U/B ↑	Voltage Unbalance Alarm/Control Pickup
VOLTAGE U/B ↓	Voltage Unbalance Alarm/Control Dropout

## Voltage Disturbance

### Main Menu

PATH: ACTUAL VALUES ⇒ A3 POWER ANALYSIS ⇒ ⬇ VOLTAGE DIST. RECORDER

■ VOLTAGE DIST. RECORDER [▷]	⏪ ⏩	3: Van SWELL 12:00:05am 01/01/03	
		MESSAGE ⏪ ⏩	2: Vbn SAG 12:00:02am 01/01/03
		MESSAGE ⏪ ⏩	1: Vcn SAG 12:00:00am 01/01/03

The Voltage Disturbance Recorder runs continuously and records the source, level and duration of each voltage disturbance. Up to 500 disturbances are recorded in a circular buffer. When over 500 disturbances are recorded, data for older disturbances are lost as new disturbances are recorded. Additionally, since the events are stored within volatile memory, the voltage disturbance recorder will lose all events upon a power loss. The time and date of when the disturbance *ended* is recorded with the disturbance event. The following available is available for each disturbance:

- **Type:** Each disturbance is classified as a **SWELL** or **SAG**. The disturbance will be distinguished as a swell if the voltage increases above the swell level, for up to 1 minute. A sag disturbance is distinguished in the same manner except that it involves a voltage decrease below the sag level.
- **Source:** The source of the disturbance is the phase voltage that recorded the disturbance; either Van, Vbn, Vcn, Vab, or Vca. If the disturbance is found on two or more phases, multiple disturbances will be recorded.

**The voltage disturbance recorder monitors only measured values. Therefore, when the Vbc (delta connection only) and Vbn (2 VT 4-Wire Wye only) phases are calculated quantities, they are not considered a source.**

The duration and average level are recorded in sub-menus as shown below.

### Sub-Menus

PATH: ACTUAL VALUES ⇒ A3 POWER ANALYSIS ⇒ ⬇ VOLTAGE DIST... ⇒ 1(500): <DIST\_TYPE>

1: Vcn SAG 12:00:00am 01/01/03	⏪ ⏩	1 DURATION: 65 cycles
		MESSAGE ⏪ ⏩

The **DURATION** is the length of time of the disturbance. If the disturbance is either a sag or a swell the duration will be recorded in cycles with a maximum possible value of 1 minute (3600 cycles at 60Hz).

The **VOLTAGE LEVEL** represents the average level in volts for the disturbance.

The voltage disturbance recorder is independent from the event recorder. The alarm events will record normally as per the conditions set within the [S4 ALARMS](#) ⇒⇩ [CONTROL](#) settings menu, regardless whether the voltage disturbance recorder is enabled or of the sag/swell level.

If an undervoltage/overvoltage alarm occurs, it is immediately recorded as an event (if enabled). On the other hand, the voltage disturbance is recorded, if enabled, once the voltage level returns to nominal and the condition is complete. As a result, the time recorded in the event recorder is the start time of the alarm condition, while the time recorded in the disturbance recorder is the end time of the condition.

## A4 Product Info

### Software Versions

PATH: ACTUAL VALUES ⇒ A4 PRODUCT INFO ⇒⇩ SOFTWARE VERSIONS

■ SOFTWARE VERSIONS [▷]	MAIN PROGRAM VER: 2.22      MAY 09, 2006
	BOOT PROGRAM VER: 3.00

MESSAGE

Product software revision information is contained in these messages.

- MAIN PROGRAM VERSION:** When referring to documentation or requesting technical assistance from the factory, record the **MAIN PROGRAM VERSION**. This value identifies the firmware installed internally in the flash memory. The title page of this instruction manual states the main program revision code for which the manual is written. There may be differences in the product and manual if the revision codes do not match.
- BOOT PROGRAM VERSION:** This identifies the firmware installed internally in the memory of the PQM II. This does not affect the functionality of the PQM II.

### Model Information

PATH: ACTUAL VALUES ⇒ A4 PRODUCT INFO ⇒⇩ MODEL INFORMATION

■ MODEL INFORMATION [▷]	ORDER CODE: PQMII-T20-C-A
	CPU SPEED: 25 MHz
	MOD NUMBER(S) : 000
	SERIAL NUMBER: C7387777
	DATE OF MANUFACTURE: Aug 29 2003

MESSAGE

MESSAGE

MESSAGE

MESSAGE

MESSAGE



<b>DATE OF CALIBRATION:</b> Aug 29 2003
--

Product identification information is contained in these messages.

- **ORDER CODE:** This indicates which features were ordered with this PQM II. T = Transducer option (T20 = 4-20 mA, T1 = 0-1 mA Analog Outputs), C = Control option, A = Power Analysis option.
- **CPU SPEED:** Newer hardware revisions support the 25 MHz CPU speed, while older revisions only support 16 MHz. Certain features are only available on the 25 MHz platform (such as the Voltage Disturbance Recorder).
- **MOD NUMBER(S):** If unique features have been installed for special customer orders, the **MOD NUMBER** will be used by factory personnel to identify the matching product records. If an exact replacement model is required, the **MAIN PROGRAM VERSION**, **MOD NUMBER(S)**, **ORDER CODE**, and **SERIAL NUMBER** should be specified with the order.
- **SERIAL NUMBER:** This is the serial number of the PQM II. This should match the number on the label located on the back of the PQM II.
- **DATE OF MANUFACTURE:** This is the date the PQM II was final tested at GE Vernova.
- **DATE OF CALIBRATION:** This is the date the PQM II was last calibrated.



# PQM II Power Quality Meter

## Chapter 7: Applications

---

### Event Recorder

#### List of Events

**The Event Recorder stores all online data in a section of non-volatile memory when triggered by an event. The PQM II defines any of the following situations as an event:**

- Analog Input Alternate Alarm
- Analog Input Alternate Alarm Clear
- Analog Input Main Alarm
- Analog Input Main Alarm Clear
- Clear Event Record
- Clock Not Set Alarm
- Clock Not Set Alarm Clear
- COM1 Fail Alarm
- COM1 Fail Alarm Clear
- COM2 Fail Alarm
- COM2 Fail Alarm Clear
- Current THD Alarm
- Current THD Alarm Clear
- Current Unbalance Alarm
- Current Unbalance Alarm Clear
- Data Log 1 Alarm
- Data Log 1 Alarm Clear

Data Log 2 Alarm  
Data Log 2 Alarm Clear  
kVA Demand Alarm  
kVA Demand Alarm Clear  
Negative kvar Alarm  
Negative kvar Alarm Clear  
Negative kvar Demand Alarm  
Negative kvar Demand Alarm Clear  
Negative kW Alarm  
Negative kW Alarm Clear  
Negative kW Demand Alarm  
Negative kW Demand Alarm Clear  
Neutral Current Demand Alarm  
Neutral Current Demand Alarm Clear  
Neutral Overcurrent Alarm  
Neutral Overcurrent Alarm Clear  
Overcurrent Alarm  
Overcurrent Alarm Clear  
Overfrequency Alarm  
Overfrequency Alarm Clear  
Overvoltage Alarm  
Overvoltage Alarm Clear  
Parameters Not Set Alarm  
Parameters Not Set Alarm Clear  
Phase A Current Demand Alarm  
Phase A Current Demand Alarm Clear  
Phase B Current Demand Alarm  
Phase B Current Demand Alarm Clear  
Phase C Current Demand Alarm  
Phase C Current Demand Alarm Clear  
Phase Reversal Alarm  
Phase Reversal Alarm Clear  
Positive kvar Alarm  
Positive kvar Alarm Clear  
Positive kvar Demand Alarm  
Positive kvar Demand Alarm Clear

Positive kW Alarm  
Positive kW Alarm Clear  
Positive kW Demand Alarm  
Positive kW Demand Alarm Clear  
Power Factor Lag 1 Alarm  
Power Factor Lag 1 Alarm Clear  
Power Factor Lag 2 Alarm  
Power Factor Lag 2 Alarm Clear  
Power Factor Lead 1 Alarm  
Power Factor Lead 1 Alarm Clear  
Power Factor Lead 2 Alarm  
Power Factor Lead 2 Alarm Clear  
Power Off  
Power On  
Pulse Count Total Alarm  
Pulse Input 1 Alarm  
Pulse Input 1 Alarm Clear  
Pulse Input 2 Alarm  
Pulse Input 2 Alarm Clear  
Pulse Input 3 Alarm  
Pulse Input 3 Alarm Clear  
Pulse Input 4 Alarm  
Pulse Input 4 Alarm Clear  
Pulse Input Total Alarm Clear  
Reset  
Self Test Alarm  
Self Test Alarm Clear  
Setpoint Access Enabled  
Switch A Alarm  
Switch A Alarm Clear  
Switch B Alarm  
Switch B Alarm Clear  
Switch C Alarm  
Switch C Alarm Clear  
Switch D Alarm  
Switch D Alarm Clear

Time Alarm  
Time Alarm Clear  
Trace Memory Trigger  
Undercurrent Alarm  
Undercurrent Alarm Clear  
Underfrequency Alarm

**Up to 150 events can be stored in non-volatile memory for retrieval and review. The Event Recorder can be enabled, disabled, or cleared via the keypad or serial port. The following data is saved when an event occurs:**

Analog Input (high)  
Analog Input (low)  
Date - Month/Day  
Date - Year  
Event Cause  
Event Number  
Frequency  
I Unbalance  
Ia  
Ia Demand  
Ia THD  
Ib  
Ib Demand  
Ib THD  
Ic  
Ic Demand  
Ic THD  
In  
In Demand  
In THD  
Internal Fault Error Code  
kVAh (high)  
kVAh (low)  
Negative kvarh (high)  
Negative kvarh (low)  
Negative kWh (low)  
Negative kWh (high)  
P3 (high)

P3 (low)  
P3 Demand (high)  
P3 Demand (low)  
Pa (high)  
Pa (low)  
Pb (high)  
Pb (low)  
Pc (high)  
Pc (low)  
PF3  
PFa  
PFb  
PFc  
Positive kvarh (high)  
Positive kvarh (low)  
Positive kWh (high)  
Positive kWh (low)  
Q3 (high)  
Q3 (low)  
Q3 Demand (high)  
Q3 Demand (low)  
Qa (high)  
Qa (low)  
Qb (high)  
Qb (low)  
Qc (high)  
Qc (low)  
S3 (high)  
S3 (low)  
S3 Demand (high)  
S3 Demand (low)  
Sa (low)  
Sa (high)  
Sb (high)  
Sb (low)  
Sc (high)

Sc (low)  
Switches and Relays States  
Time - Hours/Minutes  
Time - Seconds  
Trace Memory Trigger Cause  
Underfrequency Alarm Clear  
Undervoltage Alarm  
Undervoltage Alarm Clear  
V Unbalance  
Vab (high)  
Vab (low)  
Vab THD  
Van (high)  
Van (low)  
Van THD  
Vbc (high)  
Vbc (low)  
Vbc THD  
Vbn (high)  
Vbn (low)  
Vbn THD  
Vca (high)  
Vca (low)  
Vcn (high)  
Vcn (low)  
Vcn THD  
Voltage THD Alarm  
Voltage THD Alarm Clear  
Voltage Unbalance Alarm  
Voltage Unbalance Alarm Clear

## Access to Event Recorder Information

**There are two ways to access Event Recorder Information:**

- Access only the Records and data you wish to view
- Access the entire Event Record.

The Event Recorder is indexed by Event Number (1 to 150). To access a specific Event, the Event Number must be written to the PQM II memory map location 12C0h. The data specific to that Event can be read starting at memory map location 0AE0h. The specific Event Number must be known to read the Event Recorder in this fashion. However, this Event Number is usually not known and the entire Event Record must be read. The easiest way to do this is to read the PQM II Memory Map location 0AD0h (Total Number of Events Since Last Clear) and loop through each Event Number indicated by the value from 0AD0h, reading the associated data pertaining to each Event. This requires 1 to 150 serial reads of 170 bytes each. Once this data is obtained, it can be interpreted based upon the format of each value. It is important to note that some memory map parameters are 32 bits (4 bytes) long and require 2 registers to contain their value, one for the two high bytes and one for the two low bytes.

The operation of the Voltage Disturbance Recorder is similar to the Event Recorder. The differences between the two recorders are the Modbus addresses, the event data, and the number of events (150 compared to 500).

The PQM II uses two different group of samples. PQM II samples at the rate of 64 samples/cycle for metering calculations and uses the last 2 cycle data (128 samples) for calculating the RMS value. An RMS value based on separate group of samples (sample rate of 16 samples/cycle) is used for making faster decisions for pickup and dropout of monitoring elements.

The event time recorded in the event recorder for monitoring elements is based on the RMS value from 16 samples but the metered RMS values is based on the previous 128 samples (2 cycle data) at the time of the trigger. Since the event recorder metered data and trigger data are based on independent and different periods of sample sizes, the metered data in the event recorder may be different from the RMS value at the time of the trigger. The accuracy specifications should not be applied for the data in event recorder.

---

## Interfacing Using Hyperterminal

### Upgrading Firmware

When upgrading firmware, the PQM II may appear to lockup if there is an interruption on the communication port during the upload process. If the PQM II does not receive the necessary control signals for configuration during firmware upload, it could remain in a halted situation until reinitialized. The steps used by the EnerVista PQM Setup Software to upload firmware to the PQM II are as follows:

1. Prepare the PQM II for firmware upgrade by saving setpoints to a file.
2. Erase the flash memory and verify it to be blank.
3. Upload the new firmware.

4. Verify the CRC when upload is complete.
5. Run the new code.

If the PQM II is interrupted prior to erasing the flash memory, it could be halted in a mode where the display will read **PQM II FLASH LOADER ENTER TEXT "LOAD"**.

If the computer being used to upload firmware has a screen saver enabled, and the screen saver operates during the upload process, the communication port will be interrupted during the launch of the screen saver. It is recommended to disable any screen saver prior to firmware upload.

There are two ways to alleviate this condition: one is to cycle power to the PQM II; the second is to interface with the PQM II using a terminal program, such as Hyperterminal, and perform the upload process manually.

## Cycling Power

Remove and then re-apply control power to the PQM II. The PQM II should then run the existing firmware in its flash memory. If the PQM II does not run the firmware in flash memory, attempt the second method using Hyperterminal.

## Hyperterminal

Hyperterminal is a terminal interface program supplied with Microsoft Windows. The following procedure describes how to setup Hyperterminal.

- ▷ Run the program "hypertrm.exe" which is usually located in the Accessories folder of your PC.
- ▷ A Connection window will appear asking for a name. Use a name such as "PQM II" for the connection and click on **OK**. The following window appears.

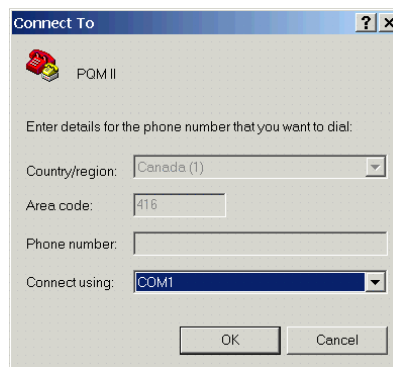

- ▷ Select the communications port of your PC that is connected to the PQM II.
- ▷ Click on **OK**.  
The following window will appear.

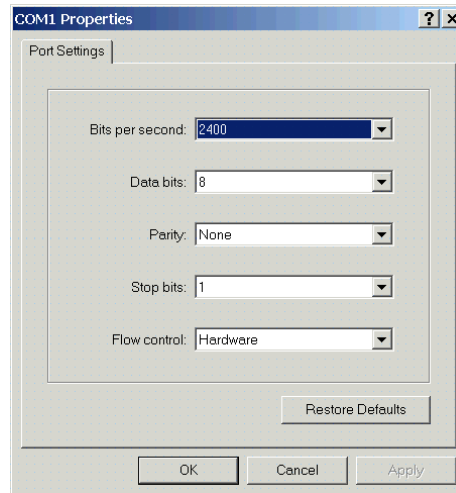

- ▷ Change the settings in the Properties window to match those shown above.
- ▷ Click on **OK**.  
You should now have a link to the PQM II.
- ▷ Enter the text **LOAD** in uppercase in the text window of Hyperterminal.  
The PQM II Boot Menu should appear in the text window.

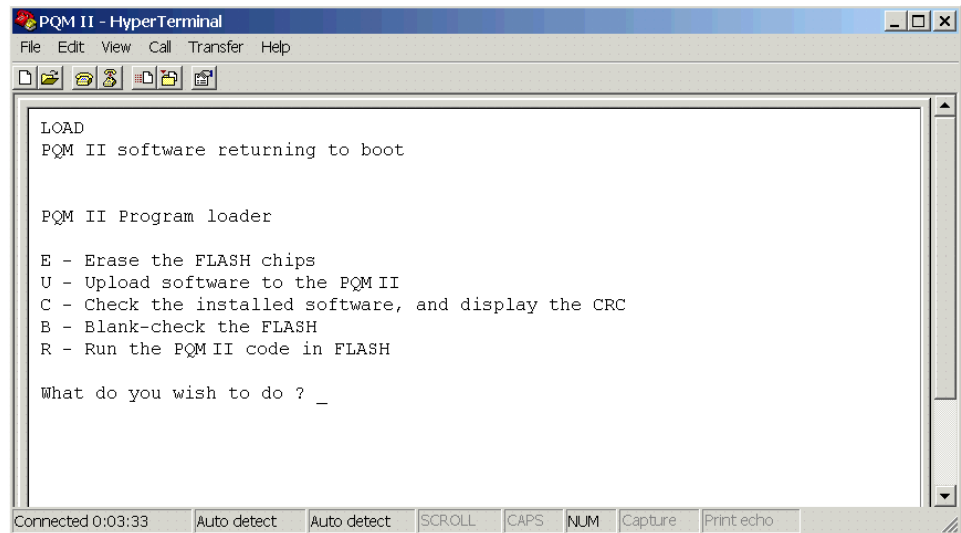

- ▷ Type “**E**” to Erase the PQM II flash memory.  
Hyperterminal will ask you to verify that you wish to erase the flash memory; enter “**Y**” for yes. The Boot Menu appears again when complete.
- ▷ Now select “**B**” to blank check the flash memory.  
The PQM II Boot Menu will appear again when complete.

- ▷ Type “**U**” to upload software to the PQM II.  
The PQM II is now waiting for a firmware file.
- ▷ Select **Transfer** then **Send File** on the Hyperterminal task bar.
- ▷ Enter the location and the name of the firmware file you wish to send to the PQM II, and ensure the Protocol is **1KXmodem**.
- ▷ Click on **Send**.  
The PQM II will now proceed to receive the firmware file, this usually takes 3 to 4 minutes. When complete the Boot Menu will again appear.
- ▷ Type “**C**” to check the installed firmware.
- ▷ Type “**R**” to run the flash.
- ▷ If the CRC check is bad, erase the flash and re-install the firmware.  
If numerous bad CRC checks are encountered, it is likely that the file you are attempting to load is corrupted. Obtain a new file and try again. If attempts to use Hyperterminal are unsuccessful, consult the factory.

---

## Phasor Implementation

### Theory of Phasor Implementation

The purpose of the function Calc\_Phasors within the PQM II firmware is to take a digitally sampled periodic signal and generate the equivalent phasor representation of the signal. In the conventional sense, a phasor depicts a purely sinusoidal signal which is what we’re interested in here; we wish to calculate the phasor for a given signal at the fundamental power system frequency. The following Discrete Fourier Series equations calculate the phasor in rectangular co-ordinates for an arbitrary digitally sampled signal. The justification for the equations is beyond the scope of this document but can be found in some form in any text on signal analysis.

$$\operatorname{Re}(g) = \frac{2}{N} \sum_{n=0}^{N-1} g_n \cdot \cos(\omega_0 n T); \quad \operatorname{Im}(g) = \frac{2}{N} \sum_{n=0}^{N-1} g_n \cdot \sin(\omega_0 n T) \quad (\text{EQ 0.1})$$

where:  $\operatorname{Re}(g)$  = real component of phasor  
 $\operatorname{Im}(g)$  = imaginary component of phasor  
 $g$  = set of N digital samples =  $\{g_0, g_1, \dots, g_{N-1}\}$   
 $g_n$  = nth sample from  $g$   
 $N$  = number of samples  
 $f_0$  = fundamental frequency in Hertz  
 $\omega_0 = 2\pi f_0$  = angular frequency in radians  
 $T = 1 / (f_0 N)$  = time between samples

The PQM II Trace Memory feature is employed to calculate the phasors. The Trace Memory feature samples 16 times per cycle for two cycles for all current and voltage inputs. Substituting  $N = 16$  (samples/cycle) into the equations yields the following for the real and imaginary components of the phasor:

$$\operatorname{Re}(g) = \frac{1}{8} \left( g_0 \cos 0 + g_1 \cos \frac{\pi}{8} + g_2 \cos \frac{2\pi}{8} + \dots + g_{31} \cos \frac{31\pi}{8} \right) \quad (\text{EQ 0.2})$$

$$\operatorname{Im}(g) = \frac{1}{8} \left( g_0 \sin 0 + g_1 \sin \frac{\pi}{8} + g_2 \sin \frac{2\pi}{8} + \dots + g_{31} \sin \frac{31\pi}{8} \right) \quad (\text{EQ 0.3})$$

The number of multiples in the above equation can be reduced by using the symmetry inherent in the sine and cosine functions which is illustrated as follows:

$$\begin{aligned} \cos \phi &= -\cos(\pi - \phi) = -\cos(\pi + \phi) = \cos(2\pi - \phi) \\ \sin \phi &= \sin(\pi - \phi) = -\sin(\pi + \phi) = -\sin(2\pi - \phi) \\ \cos \phi &= \sin\left(\frac{\pi}{2} - \phi\right) \end{aligned} \quad (\text{EQ 0.4})$$

Let  $k_1 = \cos(\pi/8)$ ,  $k_2 = \cos(\pi/4)$ ,  $k_3 = \cos(3\pi/8)$ ; the equations for the real and imaginary components are reduced to:

$$\begin{aligned} \operatorname{Re}(g) &= \frac{1}{8} (k_1(g_1 - g_7 - g_9 + g_{15} + g_{17} - g_{23} - g_{25} + g_{31}) \\ &\quad + k_2(g_2 - g_6 - g_{10} + g_{14} + g_{18} - g_{22} - g_{26} + g_{30}) \\ &\quad + k_3(g_3 - g_5 - g_{11} + g_{13} + g_{19} - g_{21} - g_{27} + g_{29}) + (g_0 - g_8 + g_{16} - g_{24})) \end{aligned} \quad (\text{EQ 0.5})$$

$$\begin{aligned} \operatorname{Im}(g) &= \frac{1}{8} (k_1(g_3 + g_5 - g_{11} - g_{13} + g_{19} + g_{21} - g_{27} - g_{29}) \\ &\quad + k_2(g_2 + g_6 - g_{10} - g_{14} + g_{18} + g_{22} - g_{26} - g_{30}) \\ &\quad + k_3(g_1 + g_7 - g_9 - g_{15} + g_{17} + g_{23} - g_{25} - g_{31}) + (g_4 - g_{12} + g_{20} - g_{28})) \end{aligned} \quad (\text{EQ 0.6})$$

The number of subtractions can be reduced between the calculations of real and imaginary components by not repeating the same subtraction twice. The following subtractions are repeated:

$$\begin{aligned} \Delta_0 &= g_0 - g_8 & \Delta_1 &= g_1 - g_9 & \Delta_2 &= g_2 - g_{10} & \Delta_3 &= g_3 - g_{11} \\ \Delta_4 &= g_4 - g_{12} & \Delta_5 &= g_5 - g_{13} & \Delta_6 &= g_6 - g_{14} & \Delta_7 &= g_7 - g_{15} \\ \Delta_8 &= g_{16} - g_{24} & \Delta_9 &= g_{17} - g_{25} & \Delta_{10} &= g_{18} - g_{26} & \Delta_{11} &= g_{19} - g_{27} \\ \Delta_{12} &= g_{20} - g_{28} & \Delta_{13} &= g_{21} - g_{29} & \Delta_{14} &= g_{22} - g_{30} & \Delta_{15} &= g_{23} - g_{31} \end{aligned} \quad (\text{EQ 0.7})$$

Substituting in the above 'delta' values results in the form of the equations that will be used to calculate the phasors:

$$\begin{aligned} \operatorname{Re}(g) &= \frac{1}{8} (\Delta_0 + \Delta_8 + k_1(\Delta_1 - \Delta_7 + \Delta_9 - \Delta_{15}) + k_3(\Delta_3 - \Delta_5 + \Delta_{11} - \Delta_{13})) \\ \operatorname{Im}(g) &= \frac{1}{8} (\Delta_4 + \Delta_{12} + k_1(\Delta_3 + \Delta_5 + \Delta_{11} + \Delta_{13}) + k_2(\Delta_1 + \Delta_7 + \Delta_9 + \Delta_{15})) \end{aligned} \quad (\text{EQ 0.8})$$

# Triggered Trace Memory

## Description

The Triggered Trace Memory can be used to detect and record system disturbances. The PQM II uses a dedicated continuous sampling rate of 16 samples per cycle to record fluctuations in voltage or current as per user defined levels. The PQM II calculates the true RMS value of one consecutive cycle, or 16 samples, and compares this value with the user-defined trigger levels to determine if it will record all sampled waveforms. The sampled waveforms include Ia, Ib, Ic, In, Va, Vb and Vc.

Since the PQM II requires a minimum 20 V for detection and has an upper voltage input limit of 600 V, the following limitation exists for the Trace Memory undervoltage and overvoltage trigger levels:

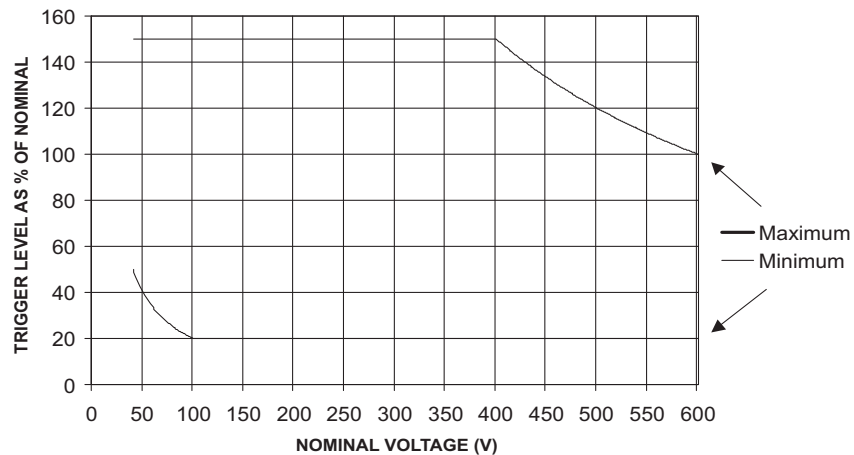

FIGURE 7-1: Trace Memory Phase Voltage Trigger Level Limits

## Pulse Output

### Pulse Output Considerations

Up to 4 SPDT Form C output relays are configurable as Pulse Initiators based on energy quantities calculated by the PQM II. Variables to consider when using the PQM II as a Pulse Initiator are:

- PQM II Pulse Output Parameter:** The PQM II activates the assigned output relay based upon the energy quantity used as the base unit for pulse initiation. These energy quantities include  $\pm$ kWhr,  $\pm$ kVARh, and kVAh.
- PQM II Pulse Output Interval:** The PQM II activates the assigned output relay at the accumulation of each Pulse Output Interval as defined by the user. This interval is based upon system parameters such that the PQM II pulse output activates at a rate not exceeding the Pulse Acceptance Capability of the end receiver.

- **PQM II Pulse Output Width:** This user defined parameter defines the duration of the pulse initiated by the PQM II when a quantity of energy equal to the Pulse Output Interval has accumulated. It is based upon system parameters such that the PQM II pulse output will activate for a duration that is within the operating parameters of the end receiver.
- **PQM II Output Relay Operation:** This user defined parameter defines the normal state of the PQM II output relay contacts, i.e. Fail-safe or Non-Failsafe.
- **Pulse Acceptance Capability of the End Receiver:** This parameter is normally expressed as any one of the following: (a) Pulses per Demand Interval; (b) Pulses per second, minute or hour; (c) Minimum time between successive closures of the contacts.
- **Type of Pulse Receiver:** There are 4 basic types of Pulse receivers: a) Three-wire, every pulse counting; b) Three-wire, every other pulse counting; c) Two-wire, Form A normally open, counts only each contact closure; d) Two-wire, counts every state change, i.e. recognizes both contact closure and contact opening.
- **Maximum Energy Consumed over a Defined Interval:** This is based upon system parameters and defines the maximum amount of energy that may be accumulated over a specific time.

## Connecting to an End Receiver Using KYZ Terminals

Typical end receivers require a contact closure between KY or KZ based upon the type of receiver. The PQM II Pulse Output feature can be used with either two- or three-wire connections. The PQM II activates the designated Output Relay at each accumulation of the defined Pulse Output Interval for the defined Pulse Output Width. Therefore, each PQM II contact operation represents one interval. For end receivers that count each closure and opening of the output contacts, the PQM II Pulse Output Interval should be adjusted to match the registration of the end receiver. For example, if the end receiver counts each closure as 100 kWh and each opening as 100 kWh, the PQM II Pulse Output Interval should be set to 200 kWh.

The PQM II Output Relays can be configured as Failsafe or Non-Failsafe to match the normally open/closed configuration of the KY and KZ connections at the end receiver. The K connection is always made to the COM connection of the designated PQM II output relay, and the Y and Z connections can be made to the N/O or N/C connections based upon the type of end receiver.

---

## Data Logger Implementation

### Data Logger Structure

The Data Logger allows various user defined parameters to be continually recorded at a user-defined rate. The Data Logger uses 64 samples/cycle data. The PQM II has allocated 196608 bytes of memory for Data Log storage. The memory structure is partitioned into 1536 blocks containing  $64 \times 2$  byte registers as shown below:

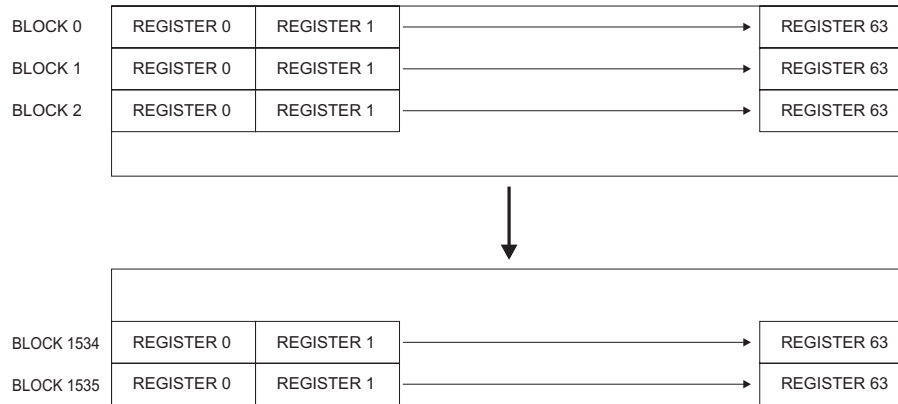

FIGURE 7-2: Data Logger Memory Structure

Each entry into the Data Log is called a Record. The Record can vary in size depending upon the parameters the user wishes to log. The memory structure can also be partitioned into 2 separate Data Logs. The size of the 2 logs is user-definable. The top of each Data Log contains what is called the Header. Each Data Log Header contains the following information:

- **Log Time Interval:** The user-defined interval that the data log stores entries.
- **Present Log Time and Date:** The time and date of the most recent Record.
- **Log Start Block #:** Block number containing the first byte of the logged data.
- **Log Start Register #:** The Register number containing the first two bytes of the logged data.
- **Log Record Size:** The size of each Record entry into the Data Log based upon the user-defined Data Log structure.
- **Log Total Records:** The total number of records available based upon the user defined Data Log parameter structure.
- **Block number of First Record:** A pointer to the block containing the first record in the Data Log.
- **Register number of First Record:** A pointer to the register containing the first record in the Data log.
- **Log Pointer to First Item of First Record:** A pointer to the first record in the Data Log.
- **Block number of Next Record to Write:** A pointer to the block containing the last record in the Data Log.
- **Register number of Next Record to Write:** A pointer to the register containing the last record in the Data Log.
- **Log Pointer to First Item of Record After Last:** A pointer to the next record to be written into the Data Log.
- **Log Status: The current status of the Data Log;** i.e.: Running or Stopped.
- **Log Records Used:** The number of records written into the Data Log.
- **Log Time Remaining Until Next Reading:** A counter showing how much time remains until the next record is to be written into the Data Log.

## Modes of Operation

The Data Logger has 2 modes of operation, Run to Fill and Circulate. In the Run to Fill mode, the Data Log will stop writing records into the memory structure when there is not enough memory to add another record. Depending on the size of each record, the Data Log may not necessarily use the entire 196,608 bytes of storage available. In the Circulate mode, the Data Log will continue to write new Records into the Log beyond the last available Record space. The Log will overwrite the first Record after the Header and continue to overwrite the Records to follow until the user wishes to stop logging data. The Log will act as a rolling window of data in time, going back in time as far as the amount of records times the Log Time Interval will allow in the total space of memory available.

## Accessing Data Log Information

The Data Log can be accessed using the EnerVista PQM Setup Software or manually via the serial port. Access via the EnerVista PQM Setup Software is described in *Data Logger* on page 4–12. Access manually via the serial port as follows:

1. Set the Block of data you wish to access at 1268h in the PQM II Memory Map.
2. Read the required amount of data from the 64 Registers in the Block.

Accessing the Data Log in this manner assumes that the user knows which Block they wish to access, and knows the size of each Record based upon the parameters they have selected to log.

The easiest way to access the data in the Data Log is to read the entire log and export this data into a spreadsheet for analysis. This requires defining the Block to be read, starting at Block 0, and reading all 128 bytes of data in each of the 64 Registers within the Block. You would then define Blocks 1, 2, 3, etc., and repeat the reading of the 64 Registers for each block, until Block 1535. This requires 1536 reads of 128 bytes each. The data can then be interpreted based upon the parameter configuration.

## Interpreting Data Log Information

Using two (2) Data Logs in the “Run to Fill” mode, the Data Log is configured as shown below.

Blocks 0 and 1 are reserved for Data Logger Data Interval information. Block 2 contains header information for both Data Logs. The first 32 registers of Block 2 are reserved for Data Log 1 header information, and the remaining 32 registers are reserved for Data Log 2 header information. The first register of Data Log information resides at Register 0 of Block 3. This leaves 196224 bytes of data storage.

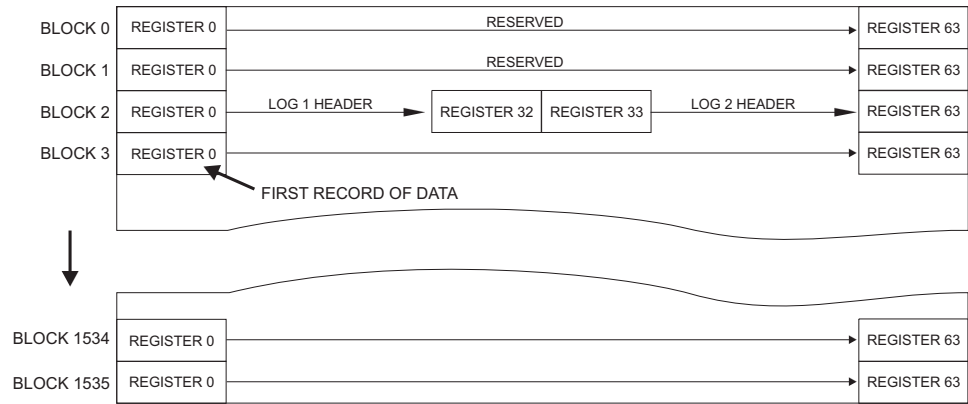

FIGURE 7-3: Data Log Configuration

The location of the first Record in Log 2 will depend upon the Log configuration. Its location is determined by reading the Log 2 Header value for Log Start Address at location 0AB2 and 0AB3 in the memory map. The Log Start Address consists of the block number (0AB2) and the register number (0AB3) which represents the location of the first record within the Data Log memory structure. This location will always be the starting address for Data Log 2 for the given configuration. Adding or deleting parameters to the configuration will change the Log 2 Starting Address.

The log pointers contain a value from 0 to 196607 representing a byte within the data Log memory structure. Add 1 to this number and then divide this number by 64 (number of registers in a Block). Then divide this number by 2 (number of bytes in a register), and truncate the remainder of the division to determine the Block number. Multiplying the remainder of the division by 64 will determine the Register number. For example, if the Log pointer: “Log 2 Pointer to First Item of First Record” was 34235, then the Block and Register numbers containing the first record of Log 2 are:

$$\text{Block Number} = (34235 + 1) / 64 / 2 = 267.46875$$

Therefore, Block Number 267 contains the starting record.

$$\text{Record Number} = 0.46875 \times 64 = 30$$

Therefore, Register Number 30 contains the first byte of Log 2 data. These calculations can be avoided by using the pre-calculated values for Block Number and Record number located just prior to the pointer (0AB7 and 0AB8).

The Data Logs will use the maximum amount of memory available, minus a 1 record buffer, based upon the user configuration. For Example, if the Record Size for a given configuration was 26 bytes, and there were 28 bytes of memory left in the memory structure, the Data Logger will not use those last 28 bytes, regardless of the mode of operation. The Data Logger uses the following formula to determine the total record space available:

$$\text{Total Space} = (196224 / \text{Record Size}) - 1$$

As in the example, the total space calculated would be  $196224 / 26 - 1 = 7546.07$ . This equates to 7546 records with 28 bytes of unused memory at the end of Block 1536. The total amount of space used in the structure can also be found in the Log Header in the Log Total Records field.

Address 1270h in the PQM II Memory Map is the Holding Register for the first available parameter for use by the Data Logs. The Data Logs will place the user-selected parameters into their respective Record structures based upon their respective order in the PQM II Memory Map.

For example, if Positive kWh, Frequency and Current Unbalance were selected as measured parameters, they would be placed into the Record structure in the following order: Unbalance (2 bytes, 16-bit value), Frequency (2 bytes, 16-bit value), and Positive kWh (4 bytes, 32-bit value). The Data Log Parameters table on the following page illustrates the order of parameters and their size.

Therefore, the Record size would be 8 bytes. To put a time value associated with each Record, you must read the Log Time and Date from the Header. This is the time of the most recent Record in the Log. To time stamp the first Record used, multiply the Log Time Interval by the Log Records Used and subtract this number from the time associated with the last Record. To determine the time associated with any Record, add the Log Time Interval times the Record to be read to the time associated with the first Record in the Log.

For example:

Log Time Interval:3600  
Log Time, Hours/Minutes:02 30  
Log Time, Seconds:30300  
Log Date, Month:06 15  
Log Date, Year:1997  
Log Records Used:1600

The last Record entry time is interpreted as 2:30 AM, 30.300 seconds, June 15, 1997. The Log Time Interval is 3600 seconds, or 1 hour. Taking the Log Records Used (1600) and multiplying this by the Log Time Interval (3600) gives 5760000 seconds. This translates into 66 days and 16 hours. Subtracting backwards on a calendar from the time for the last Record gives a time and date of 10:30:30.000 AM, April 9, 1997. This is the time stamp for the first Record. In the PQM II, the sampling time (log time interval) accuracy for the data logger is 0.15%. This could result in a different time stamp for the first record if the data logger is retrieved at a different time with a different number of records in the data logger. Time stamping the remaining Records requires adding 3600 seconds for each Record starting from the time associated with the first Record. It is important to note that when in the Circulate mode, and the Data Log fills the available memory, the Log wraps around the first available Register of the memory structure and the Log Pointer to First Item of First Record will float along in time with each additional entry into the Log. For example, if the Data Log has wrapped around the available memory more than once, the Log Pointer to First Item of First Record will always be preceded in memory by the Log Pointer to First Item of Record After Last. As each new entry is written into the Log, these two pointers move down to the next record space in memory, overwriting the first entry into the log as of the Present Log Time and Date.

## Data Log Parameters

Listed below are the parameters available for capturing data via the Data Logger. Note that these parameters will be placed within the Record structure of the Data Log in the order and size that they appear in this table.

**Table 1: Data Log Parameters**

DATA LOG PARAMETER	SIZE (bytes)	DATA LOG PARAMETER	SIZE (bytes)	DATA LOG PARAMETER	SIZE (bytes)
Ia	2	PFa	2	kVAh	4
Ib	2	Pb	4	Ia Demand	2
Ic	2	Qb	4	Ib Demand	2
Iavg	2	Sb	4	Ic Demand	2
In	2	PFb	2	In Demand	2
I Unbalance	2	Pc	4	P3 Demand	4
Van	4	Qc	4	Q3 Demand	4
Vbn	4	Sc	4	S3 Demand	4
Vcn	4	PFc	2	Ia THD	2
Vpavg	4	P3	4	Ib THD	2
Vab	4	Q3	4	Ic THD	2
Vbc	4	S3	4	In THD	2
Vca	4	PF3	2	Van THD	2
Vlavg	4	Frequency	2	Vbn THD	2
V Unbalance	2	Positive kWh	4	Vcn THD	2
Pa	4	Negative kWh	4	Vab THD	2
Qa	4	Positive kvarh	4	Vbc THD	2
Sa	4	Negative kvarh	4	Analog Input	4

where: I = current; V = Voltage; P = Real Power; Q = Reactive Power; S = Apparent Power; PF = Power Factor; THD = Total Harmonic Distortion

## Reading Long Integers from the Memory Map

### Description

The PQM II memory map contains data formatted as a long integer type, or 32 bits. Because the Modbus protocol maximum register size is 16 bits, the PQM II stores long integers in 2 consecutive register locations, 2 high order bytes, and 2 low order bytes. The data can be retrieved by the following logic:

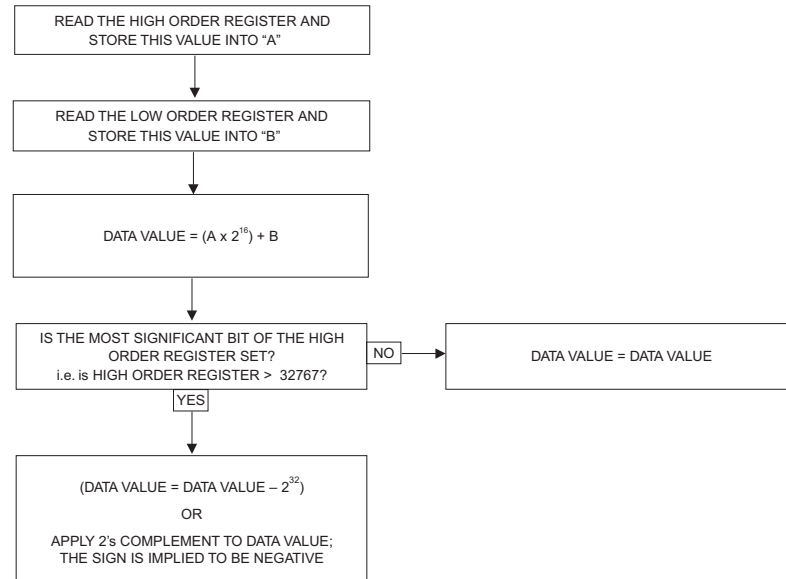

### Example

Reading a positive 3 Phase Real Power actual value from the PQM II:

Register	Actual Value	Description	Units & Scale	Format
02F0	004Fh	3 Phase Real Power (high)	0.01 × kW	F4
02F1	35D1h	3 Phase Real Power (low)	0.01 × kW	F4

Following the method described above, we have:

$$\begin{aligned}
 \text{DATA VALUE} &= (004F \times 2^{16}) + 35D1 && \text{hexadecimal} \\
 &= 5177344 + 13777 && \text{converted to decimal} \\
 &= 5191121 && \text{decimal}
 \end{aligned}$$

The most significant bit of the High Order register is not set, therefore the Data Value is as calculated. Applying the Units and Scale parameters to the Data Value, we multiply the Data Value by 0.01 kW. Therefore the resultant value of 3 Phase Real Power as read from the memory map is 51911.21 kW.

Reading a negative 3 Phase Real Power actual value from the PQM II:

Register	Actual Value	Description	Units & Scale	Format
02F0	FF3Ah	3 Phase Real Power (high)	0.01 × kW	F4

Register	Actual Value	Description	Units & Scale	Format
02F1	EA7Bh	3 Phase Real Power (low)	0.01 × kW	F4

Following the method described above:

$$\begin{aligned}
 \text{DATA VALUE} &= (\text{FF3A} \times 2^{16}) + \text{EA7B} && \text{hexadecimal} \\
 &= (65338 \times 2^{16}) + 60027 && \text{converted to decimal} \\
 &= 4282051195 && \text{decimal}
 \end{aligned}$$

The most significant bit of the High Order register is set, therefore the Data Value is:

$$\text{DATA VALUE} = \text{DATA VALUE} - 2^{32} = 4282051195 - 4294967296 = -12916101$$

Multiply the Data Value by 0.01 kW according to the Units and Scale parameter. The resultant 3 Phase Real Power value read from the memory map is -129161.01 kW.

## Pulse Input Application

### Description

The PQM II has up to 4 Logical Switch Inputs that can be configured as Pulse Input Counters. Variables to consider when using the PQM II as a Pulse Input Counter are:

- **PQM II Switch Input A(D) Function:** Defines the functionality to be provided by the PQM II Switch Input. For use as a Pulse Input Counter, the PQM II Switch Input to be used must be assigned as either Pulse Input 1, 2, 3, or 4.
- **PQM II Switch Input A(D) Activation:** Set to Open or Closed. The PQM II will see the operation of the Switch Input in the state as defined by this parameter.
- **PQM II Switch Input A(D) Name:** Defines the name given to each of the Switch Inputs used. It is used as a label only and has no bearing on the operation of the Switch Input.
- **PQM II Pulse Input (Units):** Represents the name given to the base units that the PQM II Pulse Input(s) will be counting. It is used as a label only and has no bearing on the operation of the Pulse Input.
- **PQM II Pulse Input 1(4) Value:** This value is assigned to each counting operation as determined by the Switch Input.
- **PQM II Totalized Pulse Input:** Creates a summing register of the various Pulse Inputs configured. It can be configured for any combination of the PQM II Switch Inputs used as Pulse Inputs.

### PQM II Pulse Input(s) with a Pulse Initiator using KYZ Terminals

Typical end receivers require a contact closure between KY or KZ based upon the type of receiver. Because of the multi-functional parameters of the PQM II Switch Inputs, the PQM II Switch Inputs are not labeled with KYZ markings as a dedicated pulse input device. However, the PQM II can still be used as a pulse counter. The PQM II Switch Inputs require a signal from the PQM II Switch Common terminal to be activated. The PQM II configured as a Pulse Counter can be used with Two-Wire Pulse Initiators. The Pulse Initiator must provide a dry contact operation. The Switch

Common terminal of the PQM II is connected to the K terminal of the Pulse Initiator. The PQM II Switch Input assigned to count pulses can be connected to the Y or the Z terminal of the Pulse Initiator, depending on the operation of the Pulse Initiator, i.e. Open or Closed. The PQM II Pulse Input (value) must be assigned to match the pulse value of the Pulse Initiator, i.e. if the Pulse Initiator delivers a dry contact closure for every 100kWh, the PQM II Pulse Input (value) must also be set to 100.

Various operating parameters must be taken into account. The PQM II Switch Inputs require a minimum 100ms operation time to be detected. The duration of the contact operation can be indefinite. The internal Switch Input circuit of the PQM II is itself switched on and off at the times when the PQM II is reading the status of the Switch Inputs. Monitoring the input to one of the PQM II Switch Inputs will reveal a pulsed 24VDC waveform, not a constant signal. Standard wiring practice should be adhered to when making connections to the PQM II Switch Inputs, i.e. avoiding long runs of cable along current carrying conductors or any other source of EMI. An induced voltage on the Switch Input can cause malfunction of the Switch Input.

---

## Pulse Totalizer Application

### Description

The PQM II has up to 4 Logical Switch Inputs that can be configured as Pulse Input Counters. One common application of these Pulse Inputs is their use as an energy totalizer for more than one circuit. One PQM II can totalize input from up to 4 different sources and sum these results into a single register. Variables to consider when using the PQM II as a Pulse Input Counter are:

- **PQM II Switch Input A(D) Function:** Defines the functionality to be provided by the PQM II Switch Input. For use as a Pulse Input Counter, the PQM II Switch Input to be used must be assigned as either Pulse Input 1, 2, 3, or 4.
- **PQM II Switch Input A(D) Activation:** Set to Open or Closed. The PQM II will see the operation of the Switch Input in the state as defined by this parameter.
- **PQM II Switch Input A(D) Name:** Defines the name given to each of the Switch Inputs used. It is used as a label only and has no bearing on the operation of the Switch Input.
- **PQM II Pulse Input (Units):** Represents the name given to the base units that the PQM II Pulse Input(s) will be counting. It is used as a label only and has no bearing on the operation of the Pulse Input.
- **PQM II Pulse Input 1(4) Value:** This value is assigned to each counting operation as determined by the Switch Input.
- **PQM II Totalized Pulse Input:** This parameter creates a summing register of the various Pulse Inputs configured. It can be configured for any combination of the PQM II Switch Inputs used as Pulse Inputs.

## Totalizing Energy from Multiple Metering Locations

The diagram below shows an example of a PQM II being used to totalize the energy from 4 other PQM IIs. PQM IIs 1 through 4 have each of their respective Aux1 relays configured for Pulse Output functionality (refer to : *Pulse Output* for details). The Switch Common output from PQM II#4 is fed to the common contact of the Aux1 relays on PQM IIs 1 through 4. The N/O contact of Aux1 for PQM IIs 1 through 4 will operate based upon the setup as described in the Pulse Output functionality section of the PQM II manual. The Totalized Pulse Input register of PQM II#4 can be set to sum the counts from Switch Inputs 1 through 4, thus giving a total energy representation for the 4 metering locations. The count value for each Pulse Input on PQM II#4 can be set to match the Pulse Output Interval as programmed on each PQM II. For example, if PQM II#1 had a Pulse Output Interval = 100 kWhr, and PQM II#2 had a Pulse Output Interval = 10 kWhr, then Pulse Input 1 on PQM II#4 would have the Pulse Input Value set for 100 and Pulse Input 2 on PQM II#4 would have the Pulse Input Value set for 10.

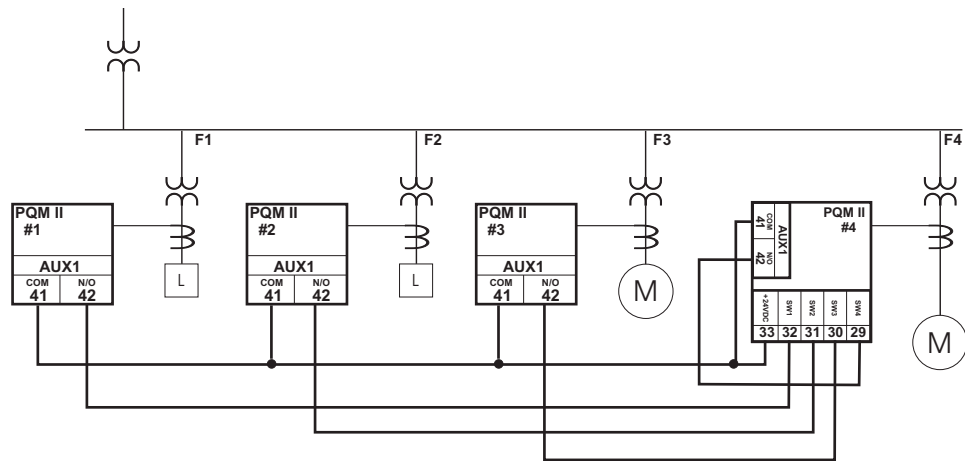

FIGURE 7-4: Multiple Metering Locations

Various operating parameters must be taken into account. The PQM II Switch Inputs require a minimum 100 ms operation time to be detected. Therefore the Pulse Output Width should be equal to or greater than 100 ms. The duration of the contact operation can be indefinite. The internal Switch Input circuit of the PQM II is switched on and off at the times when the PQM II is reading the Switch Inputs status. Monitoring the input to one of the PQM II Switch Inputs will reveal a pulsed 24 V DC waveform, not a constant signal. Standard wiring practice should be adhered to when making connections to the PQM II Switch Inputs, i.e. avoiding long runs of cable along current carrying conductors or any other source of EMI. An induced voltage on the Switch Input can cause malfunction of the Switch Input.

# PQM II Power Quality Meter

## Chapter 8: Warranty

---

### GE Vernova Warranty

#### Warranty Statement

The latest information on the GE Vernova 10-Year Worldwide Warranty can be found at: <https://www.gevernova.com/grid-solutions/multilin/warranty>



# PQM II Power Quality Meter

## Chapter A: Appendix A

### Mod 506: Capacitor Bank Switching







#### Description

















The standard PQM software has been altered to allow the four output relays to be used for 4 step capacitor bank switching.

#### Setpoints

The following messages have been added to the PQM II setpoint structure to accommodate this modification. The messages are located in setpoints page [S4 ALARMS](#) ⇄ [CONTROL](#) ⇄ [MOD 506 SETPOINTS](#) (after the [MISCELLANEOUS](#) heading).

**PATH: SETPOINTS** ⇄ [S4 ALARMS/CONTROL](#) ⇄ [MOD 506 SETPOINTS](#)

■ MOD 506 [▷] SETPOINTS		<b>STEP 1 RELAY:</b> <b>OFF</b>	<i>Range: Alarm, Aux1, Aux2, Aux3, Off</i>
MESSAGE		<b>STEP 1 PICKUP ≥</b> <b>+600 kvar</b>	<i>Range: 0.1 to 6500.0 kvar in steps of 0.1</i>
MESSAGE		<b>STEP 1 DROPOUT ≤</b> <b>0.0 kvar</b>	<i>Range: -3250.0 to 3250.0 kvar in steps of 0.1</i>
MESSAGE		<b>STEP 1 PICKUP</b> <b>DELAY: 1.0 min</b>	<i>Range: 0.1 to 60.0 min in steps of 0.1</i>
MESSAGE		<b>STEP 1 DISABLE</b> <b>TIME: 5.0 min</b>	<i>Range: 0.1 to 60.0 min in steps of 0.1</i>
MESSAGE		<b>STEP 2 RELAY:</b> <b>OFF</b>	<i>Range: Alarm, Aux1, Aux2, Aux3, Off</i>
MESSAGE		<b>STEP 2 PICKUP ≥</b> <b>+600 kvar</b>	<i>Range: 0.1 to 6500.0 kvar in steps of 0.1</i>

MESSAGE		STEP 2 DROPOUT ≤ 0.0 kvar	Range: -3250.0 to 3250.0 kvar in steps of 0.1
MESSAGE		STEP 2 PICKUP DELAY: 1.0 min	Range: 0.1 to 60.0 min in steps of 0.1
MESSAGE		STEP 2 DISABLE TIME: 5.0 min	Range: 0.1 to 60.0 min in steps of 0.1
MESSAGE		STEP 3 RELAY: OFF	Range: Alarm, Aux1, Aux2, Aux3, Off
MESSAGE		STEP 3 PICKUP ≥ +600 kvar	Range: 0.1 to 6500.0 kvar in steps of 0.1
MESSAGE		STEP 3 DROPOUT ≤ 0.0 kvar	Range: -3250.0 to 3250.0 kvar in steps of 0.1
MESSAGE		STEP 3 PICKUP DELAY: 1.0 min	Range: 0.1 to 60.0 min in steps of 0.1
MESSAGE		STEP 3 DISABLE TIME: 5.0 min	Range: 0.1 to 60.0 min in steps of 0.1
MESSAGE		STEP 4 RELAY: OFF	Range: Alarm, Aux1, Aux2, Aux3, Off
MESSAGE		STEP 4 PICKUP ≥ +600 kvar	Range: 0.1 to 6500.0 kvar in steps of 0.1
MESSAGE		STEP 4 DROPOUT ≤ 0.0 kvar	Range: -3250.0 to 3250.0 kvar in steps of 0.1
MESSAGE		STEP 4 PICKUP DELAY: 1.0 min	Range: 0.1 to 60.0 min in steps of 0.1
MESSAGE		STEP 4 DISABLE TIME: 5.0 min	Range: 0.1 to 60.0 min in steps of 0.1
MESSAGE		SYSTEM STABILIZATION TIME: 5.0 min	Range: 0.1 to 60.0 min in steps of 0.1
MESSAGE		LOW VOLTAGE LEVEL: 100 V	Range: 30 to 65000 V in steps of 10 or OFF
MESSAGE		LOW VOLTAGE DETECT DELAY: 1.0 s	Range: 0.5 to 600.0 s in steps of 0.5
MESSAGE		STEP PRIORITY: 1, 2, 3, 4	Range: 24 combinations

- **STEP 1(4) RELAY:** The state of the output relay assigned in this message will be controlled by the STEP it is assigned to. Once a relay has been assigned to a particular step, it will not activate upon any other PQM II conditions (i.e. pulse output, alarm, etc.). If a particular relay has not been assigned to any STEP, it will function as per standard PQM II implementation.
- **STEP 1(4) PICKUP:** When the three-phase kvar value is positive and it becomes equal to or exceeds the value set in this setpoint the output relay assigned to the STEP will energize providing the conditions in all other setpoints are met.

- **STEP 1(4) DROPOUT:** When the three-phase kvar value becomes less than or equal to the value set in this setpoint the output relay assigned to the STEP will de-energize. Since over compensation is possible, the dropout value can be set to negative vars.
- **STEP 1(4) PICKUP DELAY:** The STEP will turn on after the delay set in this setpoint has elapsed assuming all other conditions have been met.

This delay setting will start counting down once the [SYSTEM STABILIZATION TIME](#) setting has elapsed.

**STEP 1(4) DISABLE TIME:** When STEP turns off, it is not allowed to turn back on until the time set in this setpoint has elapsed. This allows the capacitors to discharge before being re-energized again.





- **SYSTEM STABILIZATION TIME:** When any action is performed (turning STEPS on/off or low voltage is detected), the system must be allowed to stabilize for the time set in this setpoint before any further actions can be performed. This time is necessary to allow the system to stabilize without the capacitors trying to recharge
- **LOW VOLTAGE LEVEL:** When the system voltage (average three-phase voltage) becomes equal to or less than this setpoint, all STEPS are turned off. Upon recovery (three-phase voltage is greater than this setpoint) the time set in the [SYSTEM STABILIZATION TIME](#) setpoint must have elapsed before any actions will be performed. If this feature is not required, set it to “Off”.
- **LOW VOLTAGE DETECT DELAY:** In some cases where noise or spikes are present on the line it may not be desirable to detect low voltage right away, therefore, this setpoint can be used to delay the detection until voltage is definitely low.
- **STEP PRIORITY:** The [STEP PRIORITY](#) setpoint determines the sequence the STEPS are allowed to turn on in a case where the condition may be satisfied by more than one STEP. Therefore, the STEP with the highest priority will be energized first. If the STEP with highest priority is already energized, the STEP with second highest priority will be used, and so forth. The STEP priority is set from highest to lowest (left to right) when viewing this setpoint. For example, “1,2,3,4” signifies that STEP 1 has the highest priority and STEP 4 has the lowest priority. Note that only one STEP is allowed to turn on or off at a time.

Enervista PQM II setup software does not support any MODs. The settings and metering values under this MOD can be accessed using the unit front panel or the Modbus analyzer tools.

## Actual Values

The following messages have been added to the PQM II actual values structure to accommodate this modification. The messages are located in actual values page [A2 STATUS ⇒ MOD 506 ACTUAL VALUES](#).

PATH: ACTUAL VALUES ⇌ A2 STATUS ⇌ MOD 506 ACTUAL VALUES

<p>■ MOD 506 [▶] ACTUAL VALUES</p>		<p><b>PICKUP TIMERS (min)</b> 0.0 0.0 0.0 0.0</p>
MESSAGE		<p><b>DISABLE TIMERS (min)</b> 0.0 0.0 0.0 0.0</p>
MESSAGE		<p><b>SYSTEM STABILIZATION TIMER: 5.0 min</b></p>
MESSAGE		<p><b>LOW VOLTAGE DETECT TIMER: 0.0 s</b></p>

- **PICKUP TIMERS:** These timers are loaded with the [STEP 1\(4\) PICKUP DELAY](#) setpoint settings when the required conditions are met. The timers are displayed beginning with STEP 1 on the left and ending with STEP 4 on the right.
- **DISABLE TIMERS:** These timers are loaded with the [STEP 1\(4\) DISABLE TIME](#) setpoint settings when the required conditions are met. The timers are displayed beginning with STEP 1 on the left and ending with STEP 4 on the right.
- **SYSTEM STABILIZATION TIMER:** This timer is continuously loaded with the [SYSTEM STABILIZATION TIME](#) setpoint setting and will only start to count down to 0 when the system becomes stable.
- **LOW VOLTAGE DETECT TIMER:** This timer is loaded with the [LOW VOLTAGE DETECT DELAY](#) setpoint setting when low voltage is detected and will start to count down to 0.

**If the power to the PQM II is removed all timers are cleared to 0.**

## Conditions Required to Energize a STEP

The following conditions are required to energize STEP 1. The same conditions apply to STEPS 2 through 4.

- Three-phase voltage is greater than the [LOW VOLTAGE LEVEL](#) setting.
- The system kvars are equal to or have exceeded the setting in [STEP 1 PICKUP](#) setpoint.
- The programmed [SYSTEM STABILIZATION TIME](#) has elapsed.
- The programmed [STEP 1 PICKUP DELAY](#) has elapsed.
- STEP 1 has the highest priority as set in the [STEP PRIORITY](#) setpoint or all other STEPS do not meet all of the above conditions.

## Additions to Modbus Memory Map

The following two sections are added to the Modbus Memory Map for Mod 506..

GROUP	ADDR (HEX)	DESCRIPTION	RANGE	STEP VALUE	UNITS and SCALE	FOR-MAT	FACTORY DEFAULT
MOD 506 ACTUAL VALUES	0E10	Step 1 Pickup Timer	---	---	0.1 x	F1	---
	0E11	Step 2 Pickup Timer	---	---	0.1 x	F1	---
	0E12	Step 3 Pickup Timer	---	---	0.1 x	F1	---
	0E13	Step 4 Pickup Timer	---	---	0.1 x	F1	---
	0E14	Step 1 Disable Timer	---	---	0.1 x	F1	---
	0E15	Step 2 Disable Timer	---	---	0.1 x	F1	---
	0E16	Step 3 Disable Timer	---	---	0.1 x	F1	---
	0E17	Step 4 Disable Timer	---	---	0.1 x	F1	---
	0E18	System Stabilization	---	---	0.1 x	F1	---
	0E19	Low Voltage Detect	---	---	0.1 x	F1	---
MOD 506 SETPOINT S	1300	Step 1 Relay	0 to 4	1	---	F1	0 = OFF
	1301	Step 1 Pickup Level	1 to 65000	1	kvar	F1	6000=600.0 kvar
	1302	Step 1 Dropout Level	-32000 to 32000	1	kvar	F2	0=0.0 kvar
	1303	Step 1 Pickup Delay	1 to 600	1	min	F1	10=1.0 min
	1304	Step 1 Disable Time	1 to 600	1	min	F1	50=5.0 min
	1305	Step 2 Relay	0 to 4	1	---	F1	0 = OFF
	1306	Step 2 Pickup Level	1 to 65000	1	kvar	F1	6000=600.0 kvar
	1307	Step 2 Dropout Level	-32000 to 32000	1	kvar	F2	0=0.0 kvar
	1308	Step 2 Pickup Delay	1 to 600	1	min	F1	10=1.0 min
	1309	Step 2 Disable Time	1 to 600	1	min	F1	50=5.0 min
	130A	Step 3 Relay	0 to 4	1	---	F1	0 = OFF
	130B	Step 3 Pickup Level	1 to 65000	1	kvar	F1	6000=600.0 kvar
	130C	Step 3 Dropout Level	-32000 to 32000	1	kvar	F2	0=0.0 kvar
	130D	Step 3 Pickup Delay	1 to 600	1	min	F1	10=1.0 min
	130E	Step 3 Disable Time	1 to 600	1	min	F1	50=5.0 min
	130F	Step 4 Relay	0 to 4	1	---	F1	0 = OFF
	1310	Step 4 Pickup Level	1 to 65000	1	kvar	F1	6000=600.0 kvar
	1311	Step 4 Dropout Level	-32000 to 32000	1	kvar	F2	0=0.0 kvar
1312	Step 4 Pickup Delay	1 to 600	1	min	F1	10=1.0 min	
1313	Step 4 Disable Time	1 to 600	1	min	F1	50=5.0 min	
1314	System Stabilization	1 to 600	1	min	F1	50=5.0 min	
1315	Low Voltage Detect Level	30 to 65000	1	V	F1	100 V	
1316	Low Voltage Detect Delay	5 to 6000	1	s	F1	10=1.0 s	
1317	Step Sequence	0 to 23	1	---	F42	0="1,2,3,4"	

The following memory map format has also been added:

CODE	DESCRIPTION	BITMASK
F42	Step Sequence Priority	FFFF
	0 = "1, 2, 3, 4"	---
	1 = "1, 2, 4, 3"	---
	2 = "1, 3, 2, 4"	---

CODE	DESCRIPTION	BITMAS K
	3 = "1, 3, 4, 2"	---
	4 = "1, 4, 2, 3"	---
	5 = "1, 4, 3, 2"	---
	6 = "2, 1, 3, 4"	---
	7 = "2, 1, 4, 3"	---
	8 = "2, 3, 1, 4"	---
	9 = "2, 3, 4, 1"	---
	10 = "2, 4, 1, 3"	---
	11 = "2, 4, 3, 1"	---
	12 = "3, 1, 2, 4"	---
	13 = "3, 1, 4, 2"	---
	14 = "3, 2, 1, 4"	---
	15 = "3, 2, 4, 1"	---
	16 = "3, 4, 1, 2"	---
	17 = "3, 4, 2, 1"	---
	18 = "4, 1, 2, 3"	---
	19 = "4, 1, 3, 2"	---
	20 = "4, 2, 1, 3"	---
	21 = "4, 2, 3, 1"	---
	22 = "4, 3, 1, 2"	---
	23 = "4, 3, 2, 1"	---

## Revision History

### Release Dates

Table 1: Release Dates

MANUAL	GE PART NO.	PQM II REVISION	RELEASE DATE
GEK-106435	1601-0118-A1	1.0x	17 September 2003
GEK-106435A	1601-0118-A2	1.0x	06 November 2003
GEK-106435B	1601-0118-A3	2.0x	01 December 2003
GEK-106435C	1601-0118-A4	2.0x	02 December 2003
GEK-106435D	1601-0118-A5	2.1x	18 June 2004

**Table 1: Release Dates**

MANUAL	GE PART NO.	PQM II REVISION	RELEASE DATE
GEK-106435E	1601-0118-A6	2.2x	Not released
GEK-106435F	1601-0118-A7	2.2x	15 May 2006
GEK-106435G	1601-0118-A8	2.2x	22 February 2007
GEK-106435H	1601-0118-A9	2.2x	1 October 2007
GEK-106435J	1601-0118-AA	2.2x	4 March 2008
GEK-106435K	1601-0118-AB	2.2x	25 November 2008
GEK-106435L	1601-0118-AC	2.2x	1 April 2009
GEK-106435M (GEK-106475D)	1601-0118-AD (1601-0130-A5)	2.2x	21 May 2010
GEK-106435N (GEK-106475E)	1601-0118-AE (1601-0130-A6)	2.2x	16 March 2012
GEK-106435P	1601-0118-AF	2.2x	15 January 2013
GEK-106435Q	1601-0118-AG	2.35	21 July 2017
GEK-106435R	1601-0118-AH	2.35	31 July 2024
GEK-106435S	1601-0118-AI	2.35	1 June 2026

## Release Notes

**Table 2: Major Updates for GEK-106435S**

PAGE (AF)	DESCRIPTION
Cover	Manual part number to 1601-0118-AI and order code to GEK-106435S Branding to GE Vernova
N/A	Branding to GE Vernova, Colors and formats updated
CH 1	Updated Transducer Inputs/Outputs, Control Option, Power Analysis Option, Accessories
CH 2	Wiring diagrams
CH 4	Hardware, EnerVista PQM II Setup Software, VDR, EnerVista Viewpoint Monitor,
CH 8	GE Vernova Warranty

**Table 3: Major Updates for GEK-106435R**

PAGE (AF)	DESCRIPTION
Cover	Manual part number to 1601-0118-AH and order code to GEK-106435R
1-14	Added Analog Input specification

**Table 4: Major Updates for GEK-106435Q**

PAGE (AG)	DESCRIPTION
Cover	Manual part number to 1601-0118-AG and software revision to 2.35
N/A	Branding to Grid Solutions Colors and formats updated
1-1, 1-2	Added reference to large scale fixed installations
4-3	Updated content for Installing EnerVista PQM II Software
4-9	Added new section for Converting PQM <v3.60 files for use in PQM II v2.35
N/A	Minor corrections throughout

**Table 5: Major Updates for GEK-106435P**

PAGE (AF)	DESCRIPTION
Cover	Change address, ISO logo, and inside cover template
5.20	Updated S2 System Setup—VT Wiring

**Table 6: Major Updates for GEK-106435N (GEK-106475E)**

SECT (AD)	SECT (AE)	CHANGE	DESCRIPTION
Title	Title	Update	Manual part number to 1601-0120-AE (1601-0130-A6)
1.5.2	1.5.2	Added	MOD 525 addition
1.5.3	1.5.3	Update	RS485 Accessory update

**Table 7: Major Updates for GEK-106435M (GEK-106475D)**

SECT (AC)	SECT (AD)	CHANGE	DESCRIPTION
Title	Title	Update	Manual part number to 1601-0120-AD (1601-0130-A5)
1.5.2	1.5.2	Update	MOD 506 update
A.1.2	A.1.2	Added	Note added

**Table 8: Major Updates for GEK-106435L**

SECT (AB)	SECT (AC)	CHANGE	DESCRIPTION
Title	Title	Update	Manual part number to 1601-0120-AC
---	---	Update	New Communications Guide (formerly Ch.7)
1.6.1	1.6.1	Update	Revised Current Inputs section
5.5.1	5.5.1	Added	Note added
6.4.5	6.4.5	Update	SAG Voltage references

**Table 9: Major Updates for GEK-106435J**

SECT (A9)	SECT (AA)	CHANGE	DESCRIPTION
Title	Title	Update	Manual part number to 1601-0120-AA
All	All	Update	Re-establish all cross-references

**Table 10: Major Updates for GEK-106435H**

SECT (A8)	SECT (A9)	CHANGE	DESCRIPTION
Title	Title	Update	Manual part number to 1601-0120-A9
8.6.4	8.6.4	Update	(p.19) Time Stamping - sampling time accuracy

**Table 11: Major Updates for GEK-106435G**

PAGE (A7)	SECT (A8)	CHANGE	DESCRIPTION
Title	Title	Update	Manual part number to 1601-0120-A8
	1.6.1	Update	Voltage Input Specification change
	5.2.6	Text Addn.	Modbus time and date setting
	2.2.8	Text Change	Switch Input

**Table 12: Major Updates for GEK-106435F**

PAGE (A5)	PAGE (A7)	CHANGE	DESCRIPTION
Title	Title	Update	Manual part number to 1601-0120-A7
7-9	7-9	Update	Updated Modbus Memory Map
7-58	7-58	Update	Updated Default Variations section
7-59	7-59	Update	Updated Binary Input/ Binary Input Change section
7-62	7-62	Update	Updated Analog Input/Output Change section

PAGE (A5)	PAGE (A7)	CHANGE	DESCRIPTION
Title	Title	Update	Manual part number to 1601-0120-A7
7-9	7-9	Update	Updated Modbus Memory Map
7-58	7-58	Update	Updated Default Variations section
7-59	7-59	Update	Updated Binary Input/ Binary Input Change section
7-62	7-62	Update	Updated Analog Input/Output Change section

# Index

---

## A

ACTUAL VALUES	
main menu .....	6-1
viewing with EnerVista PQM II setup software .....	4-11
ALARM LED .....	3-2
ALARM RELAY	
description .....	2-14
LED indicator .....	3-3
setpoints .....	5-31
ALARMS	
actual values .....	6-17
introduction .....	1-5
setpoints .....	5-32
ANALOG INPUT	
actual values .....	6-16
description .....	2-17
multiplexing .....	2-16
setpoints .....	5-25
simulation .....	5-51
ANALOG OUTPUTS	
connection .....	2-17
description .....	2-16
parameters .....	5-23
setpoints .....	5-21
simulation .....	5-50
specifications .....	1-14
APPLICATION NOTES .....	7-1
APPLICATIONS OF THE PQMII .....	1-2
AUXILIARY RELAYS	
description .....	2-14
LED indicators .....	3-3
setpoints .....	5-31

## B

BAUD RATE .....	5-7
-----------------	-----

## C

CALCULATION PARAMETERS .....	5-10
CAPACITOR BANK SWITCHING .....	5-42, A-1
CHANGES TO MANUAL .....	A-9, A-10
CLEAR DATA .....	5-12
CLOCK	
actual values .....	6-20
clock not set alarm .....	5-48
specifications .....	1-17
COMMUNICATIONS	
description .....	2-17, 2-19
failure alarm .....	5-48
introduction .....	1-5
LEDs .....	3-2
RS232 .....	2-19, 4-2, 4-4
RS485 .....	2-17, 2-19, 4-3, 4-4
setpoints .....	5-7, 5-8
specifications .....	1-17
wiring .....	4-2, 4-3
CONTROL POWER	

description .....	2-13
on label .....	2-2
options .....	1-13
specifications .....	1-18
COST .....	5-11
CPU SPEED .....	6-29
CREST FACTOR .....	6-21
CTs	
description .....	2-13
setpoints .....	5-19
specifications .....	1-13
CURRENT ALARMS	
setpoints .....	5-32
CURRENT INPUTS	
description .....	2-13
setpoints .....	5-19
specifications .....	1-13
CURRENT METERING	
actual values .....	6-3
clearing values .....	5-12
CURRENT TRANSFORMERS	
see entry for CTs	
CURRENT UNBALANCE .....	5-35, 6-4
CYCLING POWER .....	7-8

---

## D

DATA LOGGER	
accessing .....	7-15
actual values .....	6-22
implementation .....	7-13
interpreting .....	7-15
memory full alarm .....	5-48
parameters .....	7-18
setpoints .....	5-30
with software .....	4-15
DATE .....	5-8
DEFAULT MESSAGES	
adding .....	3-7
default message time .....	5-5
deleting .....	3-7
description .....	3-7
DEFAULT SETPOINTS .....	5-13
DEMAND	
actual values .....	6-13
calculation methods .....	5-10
clearing .....	5-12
setpoints .....	5-44
specifications .....	1-17
DIELECTRIC STRENGTH TESTING .....	2-20
DISPLAY .....	3-1
DISPLAY FILTERING .....	5-5
DNP COMMUNICATIONS	
setpoints .....	5-8

---

## E

ENERGY	
actual values .....	6-11
clearing .....	5-12
cost .....	5-11
ENERVISTA PQMII SETUP SOFTWARE	

see entry for SOFTWARE	
ENERVISTA VIEWPOINT WITH THE PQMII .....	4-19
ENTER KEY .....	3-4
ESCAPE KEY .....	3-3
EVENT RECORDER .....	7-1
accessing .....	7-6
actual values .....	6-23
applications .....	7-1
clearing .....	5-13
list of events .....	6-23, 7-1
setpoints .....	5-13
EXTERNAL CONNECTIONS .....	2-3
EXTRACT FUNDAMENTAL .....	5-10

---

## F

FACTORY MODIFICATIONS .....	1-13
FEATURES .....	1-2, 1-4, 1-5
FIRMWARE	
upgrading via EnerVista PQMII setup software .....	4-5
upgrading via HyperTerminal .....	7-7
FREQUENCY METERING	
actual values .....	6-14
clearing values .....	5-13
FREQUENCY RELAYS	
setpoints .....	5-38
FRONT PANEL .....	3-1

---

## H

HARMONICS	
introduction .....	1-9
specifications .....	1-15
viewing with software .....	4-12
Help, getting .....	1-2
HI-POT TESTING .....	2-20
HYPERTERMINAL .....	7-8
communications .....	7-10
interfacing with the PQMII .....	7-7

---

## K

KEYPAD .....	3-3, 3-6
--------------	----------

---

## L

LABEL .....	2-2
LED INDICATORS .....	3-2

---

## M

MENU KEY .....	3-3
MESSAGE KEYS .....	3-5
METERING	
introduction .....	1-5
specifications .....	1-15
MISCELLANEOUS ALARMS .....	5-48
MOD 506 .....	A-1
MODBUS COMMUNICATIONS	

address.....	5-7
reading long integers.....	7-19
MODEL INFORMATION .....	6-28
MODEL NUMBER (ON LABEL).....	2-2
MODIFICATIONS.....	1-13, 6-29
MOUNTING .....	2-1

---

## O

OPTIONS .....	5-18
ORDER CODES .....	1-12, 6-29
OUTPUT RELAYS	
alarm relay .....	2-14, 5-31
auxiliary relays.....	2-14
description .....	2-14
setpoints .....	5-31
specifications .....	1-15
OVERCURRENT .....	5-34
OVERFREQUENCY	
setpoints .....	5-39
specifications .....	1-16
OVERVOLTAGE	
setpoints .....	5-35
specifications .....	1-16

---

## P

PACKAGING .....	1-19
PARITY .....	5-8
PHASE CTs	
see entry for CTs	
PHASE OVERCURRENT .....	5-34
PHASE REVERSAL .....	5-36
PHASE UNDERCURRENT .....	5-34
PHASORS	
actual values.....	6-7
applications.....	7-10
PHYSICAL DIMENSIONS.....	2-1
POWER ALARMS	
setpoints .....	5-39
POWER ANALYSIS	
with EnerVista PQMII setup software .....	4-11
POWER FACTOR	
setpoints .....	5-41
specifications .....	1-17
POWER METERING	
actual values.....	6-7
clearing values.....	5-13
conventions .....	6-11
POWER QUALITY .....	6-20
PRODUCT LABEL .....	2-2
PRODUCT OPTIONS.....	5-18
PROGRAM LED.....	3-2
PROGRAMMABLE MESSAGE	
actual values.....	6-20
setpoints .....	5-17
PULSE COUNTER .....	6-15
PULSE INPUT	
actual values.....	6-15
applications.....	7-20
clearing values.....	5-13
setpoints .....	5-46

specifications .....	1-14
PULSE OUTPUT	
applications .....	7-12
setpoints .....	5-28
specifications .....	1-14
PULSE TOTALIZER APPLICATION .....	7-21

---

## R

RESET KEY .....	3-4
REVISION HISTORY .....	2-2
RS232 COMMUNICATIONS	
configuring with EnerVista PQMII setup .....	4-4
connections .....	2-19, 4-2
setpoints .....	5-7
RS485 COMMUNICATIONS	
configuring with EnerVista PQMII setup .....	4-4
connections .....	2-17, 2-19, 4-3
setpoints .....	5-7
RX1 LED .....	3-2
RX2 LED .....	3-3

---

## S

SECURITY .....	3-6
SELF-TEST LED .....	3-2
SERIAL NUMBER .....	2-2, 6-29
SERVICE PASSCODE .....	5-52
SETPOINT ACCESS	
security .....	3-6
through switch inputs .....	2-15
SETPOINTS	
entering with EnerVista PQMII setup software .....	4-10
entry methods .....	5-1
loading factory default .....	5-13
loading from a file .....	4-9
main menu .....	5-2
saving to a file .....	4-5
setpoint access .....	5-5
SIMULATION	
current .....	5-49
voltage .....	5-49
SIMULATION LED .....	3-2
SINGLE LINE DIAGRAM .....	1-3
SOFTWARE	
actual values .....	4-11
description .....	1-11
entering setpoints .....	4-10
hardware requirements .....	4-1
installation .....	4-3
loading setpoints .....	4-9
overview .....	4-1
saving setpoints .....	4-5
serial communications .....	4-4
SPECIFICATIONS .....	1-13
STATUS INDICATORS .....	3-2
Support, technical .....	1-2
SWITCH INPUTS	
actual values .....	6-19
description .....	2-14
setpoints .....	5-27
simulation .....	5-51

specifications .....	1-14
wiring .....	2-15
SWITCH STATUS .....	6-19

---

## T

TARIFF PERIOD .....	5-11
Technical support .....	1-2
TEST LEDs .....	5-49
TEST RELAYS .....	5-49
THD	
actual values .....	6-21
clearing values .....	5-13
setpoints .....	5-37
THDF .....	6-21
TIME .....	5-8
TIME RELAY .....	5-47
TOTAL HARMONIC DISTORTION	
see entry for THD	
TRACE MEMORY	
introduction .....	1-10
setpoints .....	5-14
specifications .....	1-14
triggered trace memory resolution .....	7-12
with software .....	4-13
TRANSFORMER HARMONIC DERATING FACTOR .....	6-21
TX1 LED .....	3-2
TX2 LED .....	3-3

---

## U

UNDERCURRENT .....	5-34
UNDERFREQUENCY	
setpoints .....	5-38
specifications .....	1-16
UNDERVOLTAGE	
setpoints .....	5-34
specifications .....	1-16
UPGRADING FIRMWARE .....	4-5

---

## V

VALUE KEYS .....	3-5
VERSIONS .....	6-28
VOLTAGE ALARMS	
setpoints .....	5-32
VOLTAGE DISTURBANCE RECORDER	
actual values .....	6-27
clearing .....	5-13
settings .....	5-30
specifications .....	1-15, 1-17
VOLTAGE INPUTS	
description .....	2-13
setpoints .....	5-19
specifications .....	1-13
VOLTAGE METERING	
actual values .....	6-5
clearing values .....	5-12
VOLTAGE TRANSFORMERS	
see entry for VTs	
VOLTAGE UNBALANCE .....	5-36, 6-6

VT RATIO .....	5-19
VT WIRING .....	5-19
VTs	
description .....	2-13
setpoints .....	5-19
specifications .....	1-13

---

## W

WAVEFORM CAPTURE	
introduction .....	1-9
with software .....	4-11
WIRING .....	2-5, 2-6, 2-8, 2-9, 2-10, 2-11

