



Anti-avalanche upgrade for MV7 drives

An advanced approach to protect the IGBTs of MV7 from short circuit propagation

State-of-the-art technology

In the low probability case of IGBT failure during short circuit, there is a high risk of propagation to other components leading to a significant loss of availability of the drive. Ensuring equipment availability with the latest technology will help customers avoid major equipment failure, minimize costly downtime and improve reliability of your system.

GE has introduced a new “Anti-Avalanche Software” feature to enhance IGBT protection which will help you to overcome the propagation of IGBT failures. The new upgraded software provides robust monitoring of IGBT control switching sequences. Ultra fast short circuit detection will apply a blocking sequence to limit voltage across healthy IGBTs and enable the drive to be stopped in a controlled manner and placed in safe mode avoiding an avalanche of the breakdown.

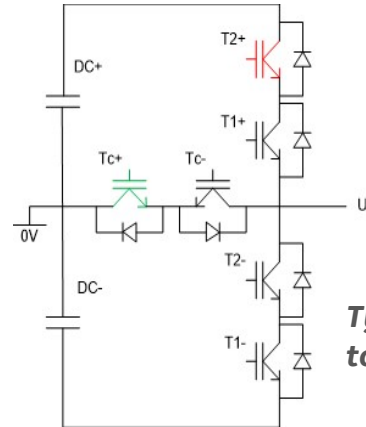

Typical MV7XXX topology (NPP)

Benefits

- Subsequent short circuit spreads will be prevented, thus limiting the amount of damage to a single component.
- Single damaged stick will be replaced instead of complete stack.
- Recovery time of the drives will be reduced.
- Operational expenditure will be limited.
- Limited storage is sufficient to store sticks instead of complete stack.
- Complete end to end support including documentation by GE experts.

How do we do? Here’s an overview!

<p>1 GDR115 GDR111 gate drivers will be changed to GDR115.</p> 	<p>1 Gate driver New firmware will be uploaded in PIB671 gate drives.</p> 
<p>2 PIBe New firmware will be uploaded in the PIBe.</p> 	<p>2 PIBe New firmware will be uploaded in the PIBe.</p> 
<p>3 CPU New software will be uploaded in the CPU (Rxi).</p> 	<p>3 CPU New software will be uploaded in the CPU.</p> 

Latest drives

Legacy drives

GE’s services for a lifetime

GE offers bespoke service support in the form of spares and replacement parts, onsite and remote technical support, maintenance services, upgrades, customized trainings and service agreements aimed at supporting customers based on their unique needs.

CONTACTUS: services.powerconversion@ge.com

Salient points

- *It is applicable to MV7315 & MV7312 drives equipped with either GDR111 or PIB671 gate driver for Marine and MV7 3kV range drives (DFE driver for Induction motor) for O&G, IPWW.*
- *Field Service Engineer (FSE) implementation time on site will be 1 FSE day/converter.*
- *GE recommends to add this protection function during the next opportunity.*