



GE VERNOVA

Power Conversion & Storage

MV8

**NEXT GEN MEDIUM VOLTAGE DRIVE
UP TO 13.8KV/26MVA**



governova.com

GE Vernova Power Conversion & Storage

As innovators in advanced energy conversion and storage systems, we empower our utility and industrial customers by solving their most challenging electrification problems and accelerating their transition to a sustainable, decarbonized future.

THE ENERGY TO CHANGE THE WORLD

WHAT WE DO



Innovation is our DNA. More than 2,000 engineers and R&D associates collaborate with GE Vernova's Global Research Business to advance fundamental energy conversion technologies.



Our expertise includes pioneering developments in superconductivity, energy storage, power systems, high-speed motors, permanent magnet generators and high-voltage direct current systems.



Our mission is to transform energy to improve customer processes. We solve recurring problems such as turning electrical energy into mechanical energy by a motor, turning mechanical energy into electrical energy by a generator or adjusting the frequency and current by means of a converter or inverter



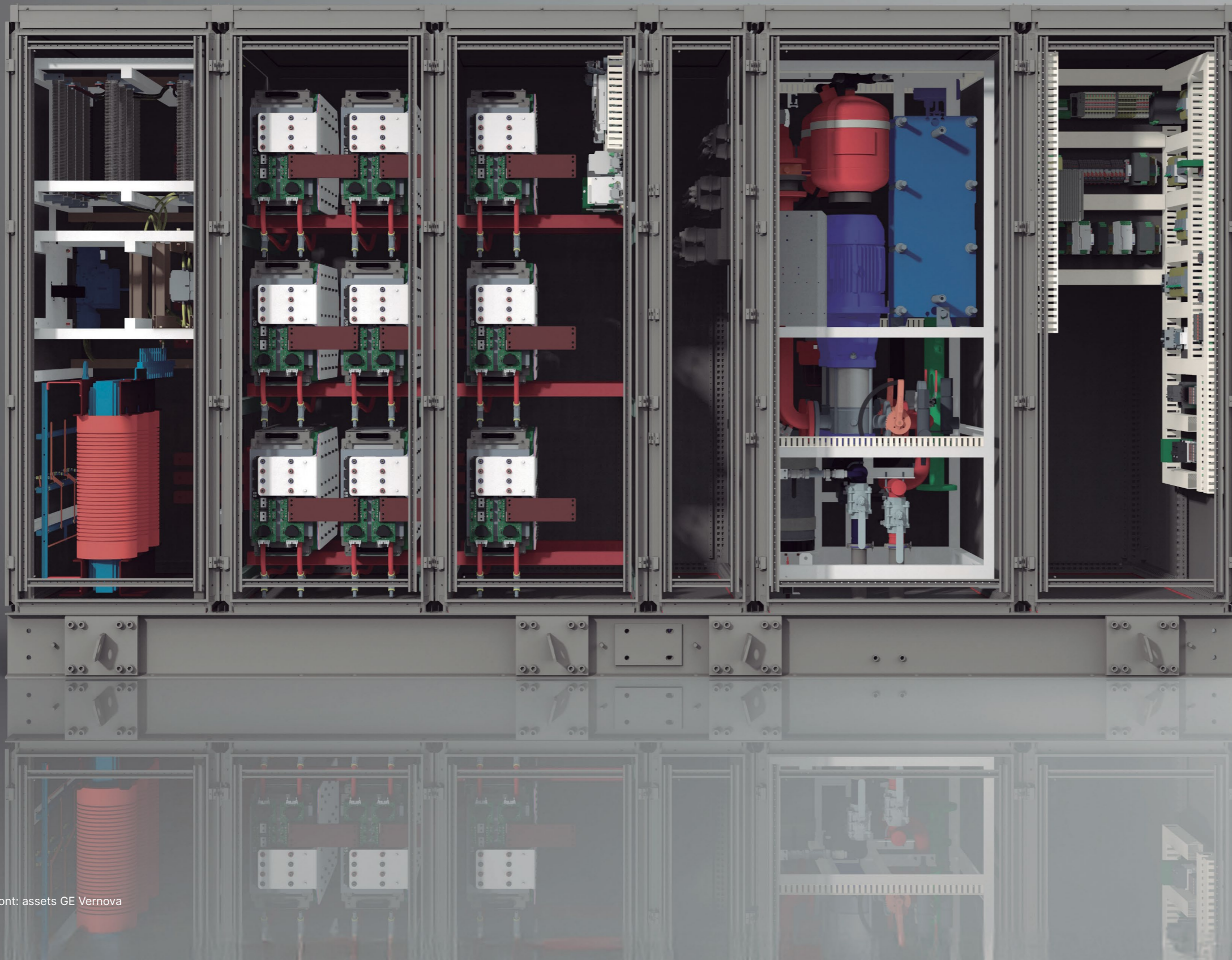

CONTENTS

- Sustainability Overview 8
- Applications and Benefits 10
- MV8 Portfolio 12
- Order Code..... 13
- MV8 Overview 16
- Submodule Design 18
- Technical Characteristics 20

ALIGNING GE VERNOVA'S BUSINESS SUCCESS WITH SUSTAINABILITY SUCCESS

OUR SUSTAINABILITY FRAMEWORK

Catalyze access to more secure, sustainable, reliable, and affordable electricity, and help drive global economic development

LEADING GOALS



Be a leading provider of new power generating capacity and grid capacity for the world



Address electrification in regions underserved by reliable, affordable, and sustainable electricity



Support workforce development, with a focus on underserved populations globally

Innovate more while using less, safeguarding natural resources

LEADING GOALS



Carbon neutrality for Scope 1 and 2 GHG emissions by 2030



90% of our top products covered by our 4R circularity framework by 2030

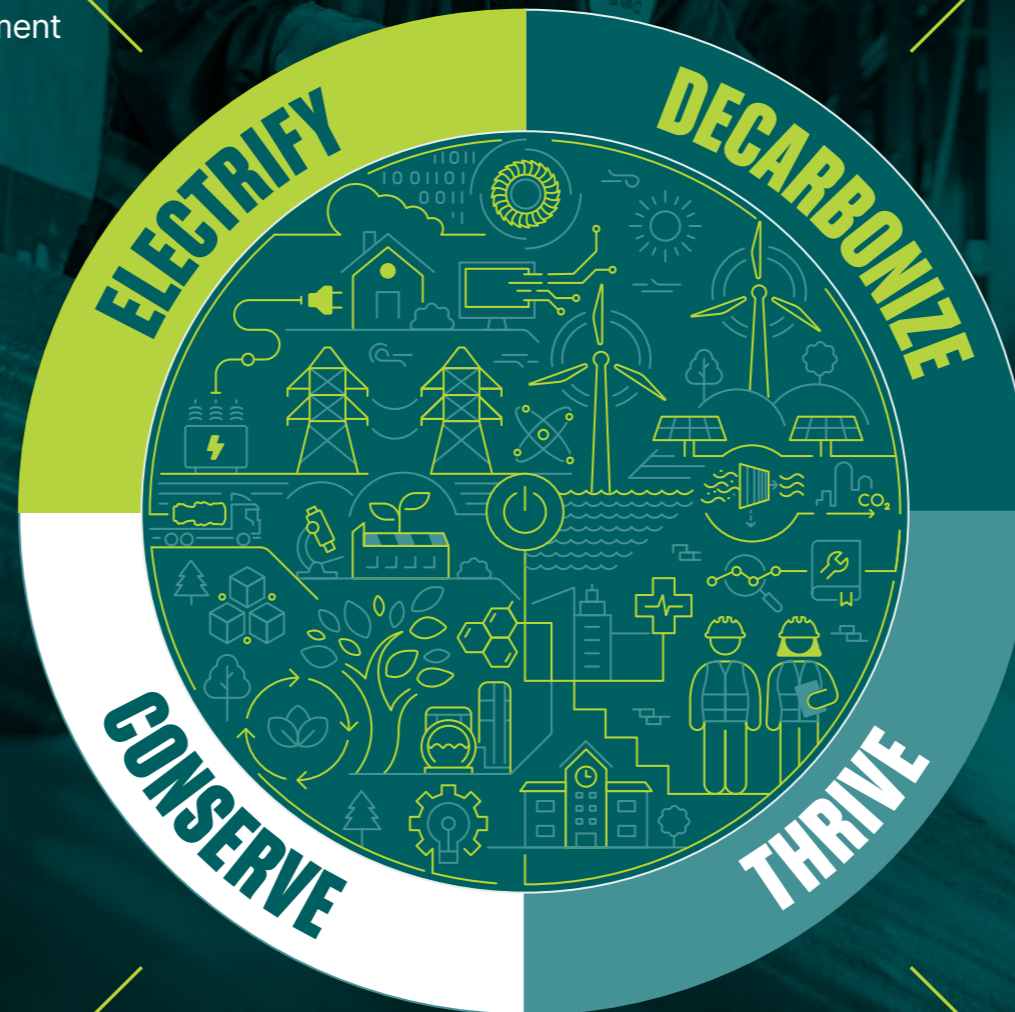

Invent, deploy, and service the technology to help decarbonize and electrify the world

LEADING GOALS



Improve the trajectory on carbon intensity for near-term impact



Innovate toward our 2050 Scope 3 net zero ambition for use of sold products

Advance safe, responsible, and fair working conditions in our operations and across our value chain

LEADING GOALS



Fatality-free operations



Demonstrate progress on inclusive culture and equal employment opportunity for all employees



Embed and implement ethical decision-making into business decisions



Partner with suppliers to promote and uphold human rights in our value chain

APPLICATIONS

INDUSTRIAL



MARINE



MINING



OIL & GAS



POWER QUALITY

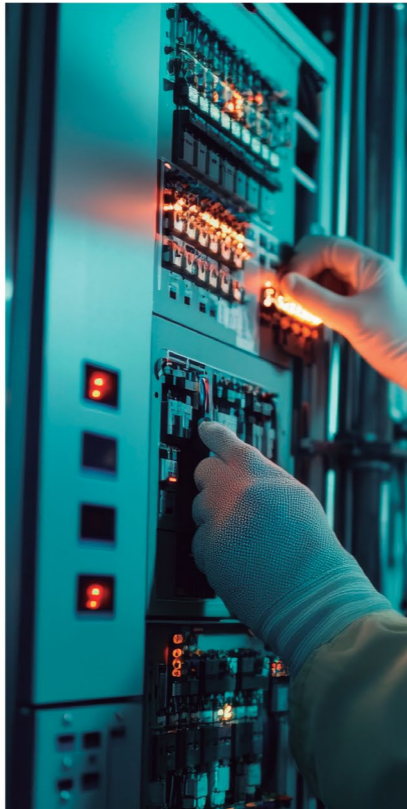

METAL INDUSTRY



BENEFITS



Consolidated LV IGBT Design: Incorporates a robust low-voltage IGBT for enhanced performance.



Maintenance-Friendly: Simplified design results in fewer repairs and reduced spare parts requirements. Front access only.



Superior Output Quality: Achieves low THD without the need for a sinus filter.



Reduced Voltage Stress: Offers low output dV/dT for improved system reliability.



Integrated Input Transformer: Facilitates seamless integration and efficiency.



Modular Submodule Components: Features replaceable submodules for easy servicing.



High Efficiency: Designed to minimize switching losses, ensuring energy efficiency.



Cost-Effective Solution: Balances performance with economical operation.

MV8 PORTFOLIO

MV8 represents the next generation of GE Vernova's medium voltage drives, designed to address the portfolio gap from 4.16 kV to 13.8 kV and 8-20 MW water-cooled products. The modular design features standardized cell configurations that offer enhanced flexibility. Each additional cell increases the achievable voltage, facilitating straightforward customization to meet specific client requirements.

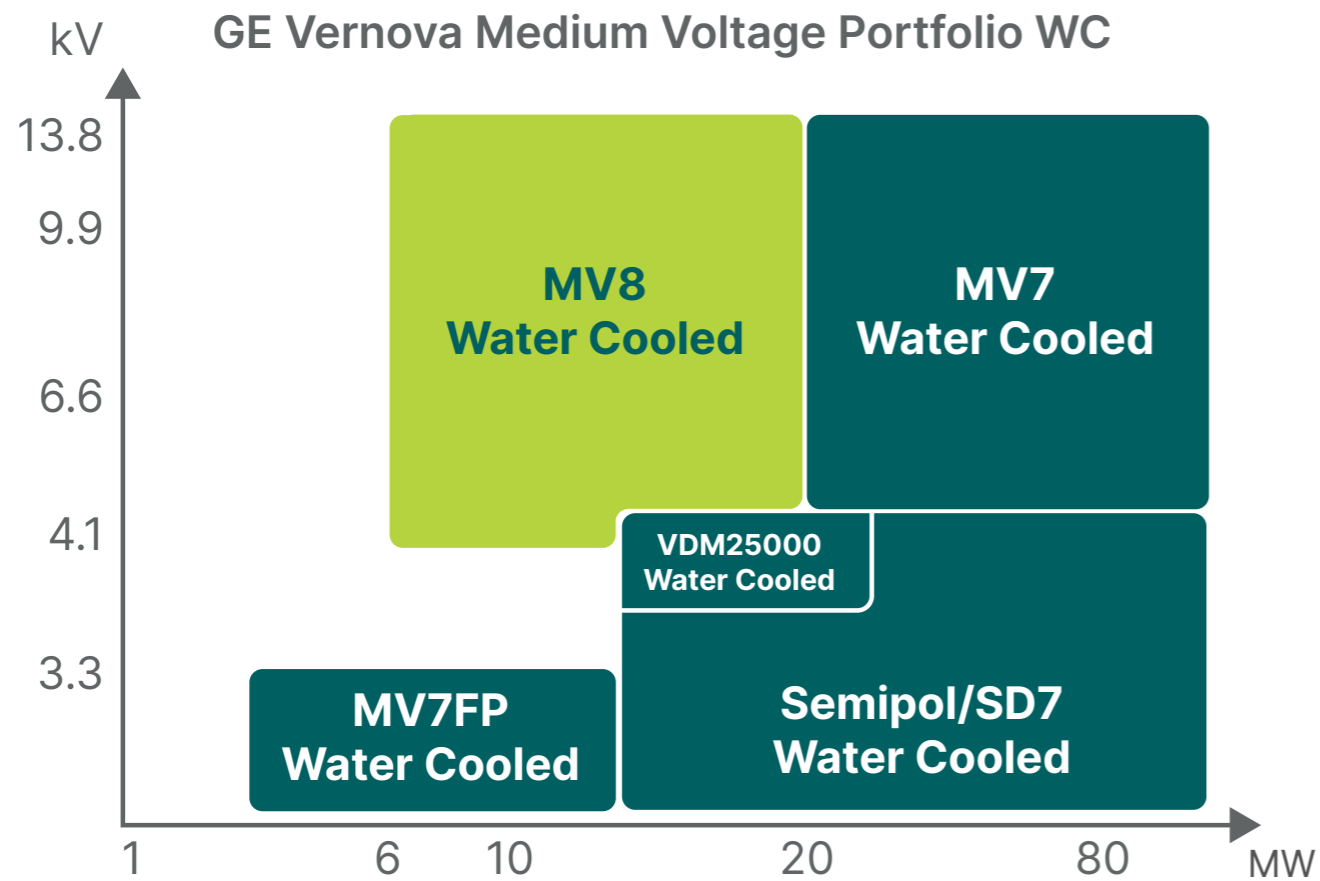

The following table illustrates the relationship between output power and output voltage across various configurations, as well as the minimum number of cells required as a function of output voltage.

| OUTPUT CHARACTERISTICS | MV8409 | MV8613 | MV8715 | MV8819 | MV8C26 | MV8D25* |
|--|---|--|--|--|--|--|
| Motor Shaft Power (MW) PF=0.85 / Eff.=97% / F=60Hz / Grid: +/-5% | 7.4 MW | 10.7 MW | 12.9 MW | 15.8 MW | 21.5 MW | 21 MW |
| Rated Output Voltage (3-phase) | 4.16 kV | 6 kV | 7.2 kV | 8.8 kV | 12 kV | 13.8 kV |
| VFD Output Power (MVA) F=60Hz / Grid +/-5% | 9 MVA | 13 MVA | 15 MVA | 19 MVA | 26 MVA | 25 MVA |
| Converter Supply | Integrated Dry-Type Transformer 9 Secondaries | Integrated Dry-Type Transformer 12 Secondaries | Integrated Dry-Type Transformer 15 Secondaries | Integrated Dry-Type Transformer 18 Secondaries | Integrated Dry-Type Transformer 24 Secondaries | Integrated Dry-Type Transformer 27 Secondaries |

Converter capable of operating at +/-5% grid variation with constant power
*Specific configuration with derated current for soft starter applications

ORDER CODE

MV8 can be ordered by specifying both the rated output voltage and the rated output power.

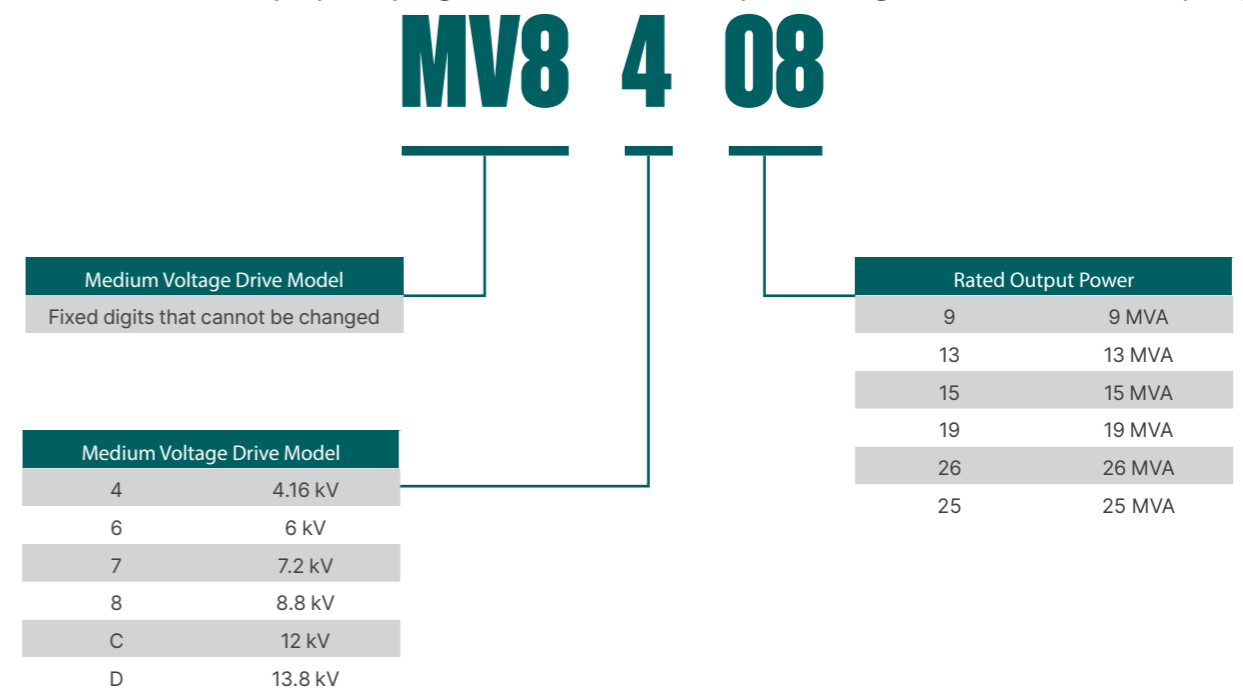

MV8 OVERVIEW

The MV8 utilizes a Cascaded H-Bridge (CHB) topology, beginning with a transformer at the input stage. Power then passes through an inverter block composed of multiple cells, each incorporating a diode rectifier bridge, a DC bus, and an H-Bridge. The system integrates water cooling for thermal management and includes a comprehensive control platform that manages drive control, system referencing, and auxiliary functions.

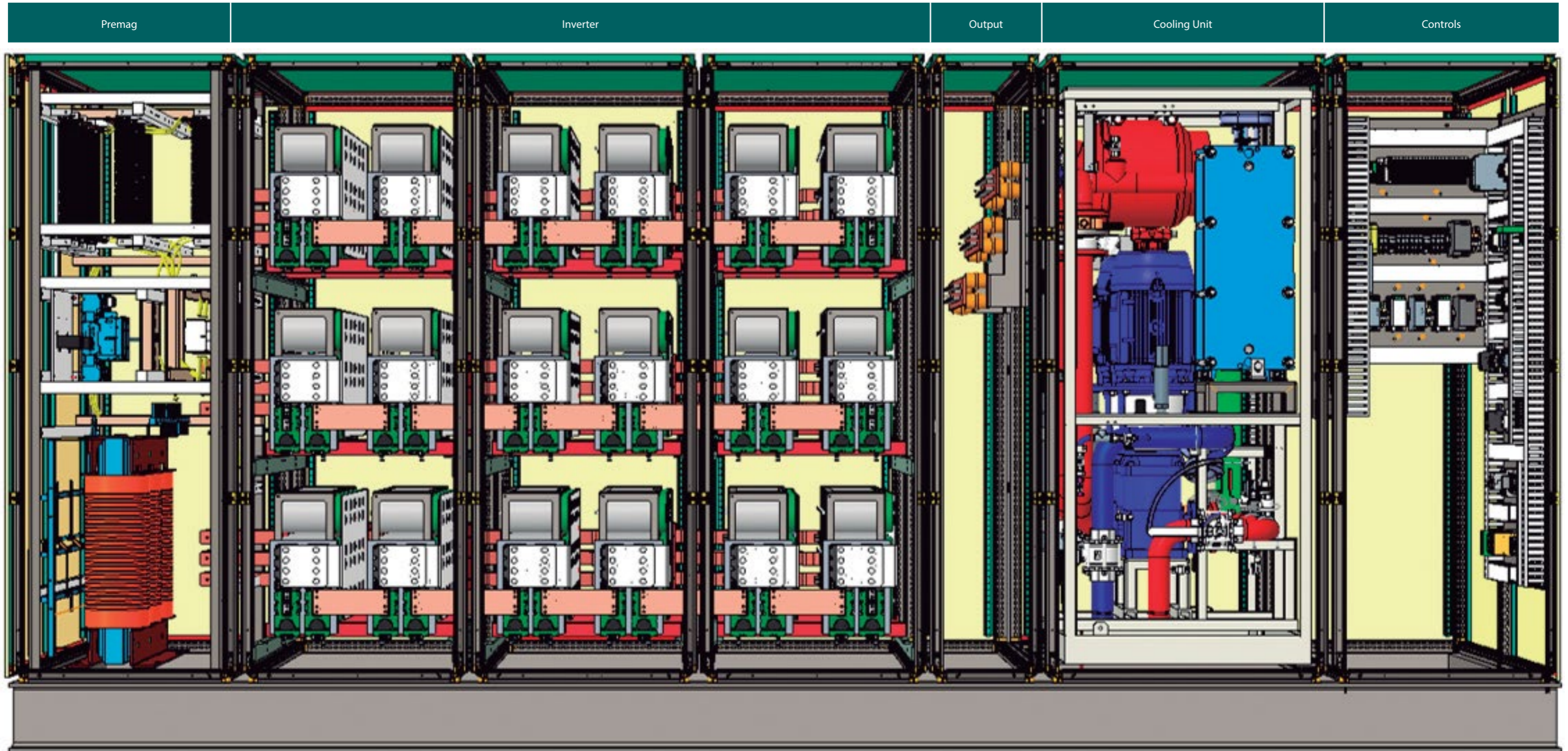

SUBMODULE DESIGN

The submodule design exhibits synergy with various Power Conversion & Storage products, including FLEXINVERTER, among others. It is engineered for rapid and efficient maintenance, requiring less than 0.5 hours to be exchanged.

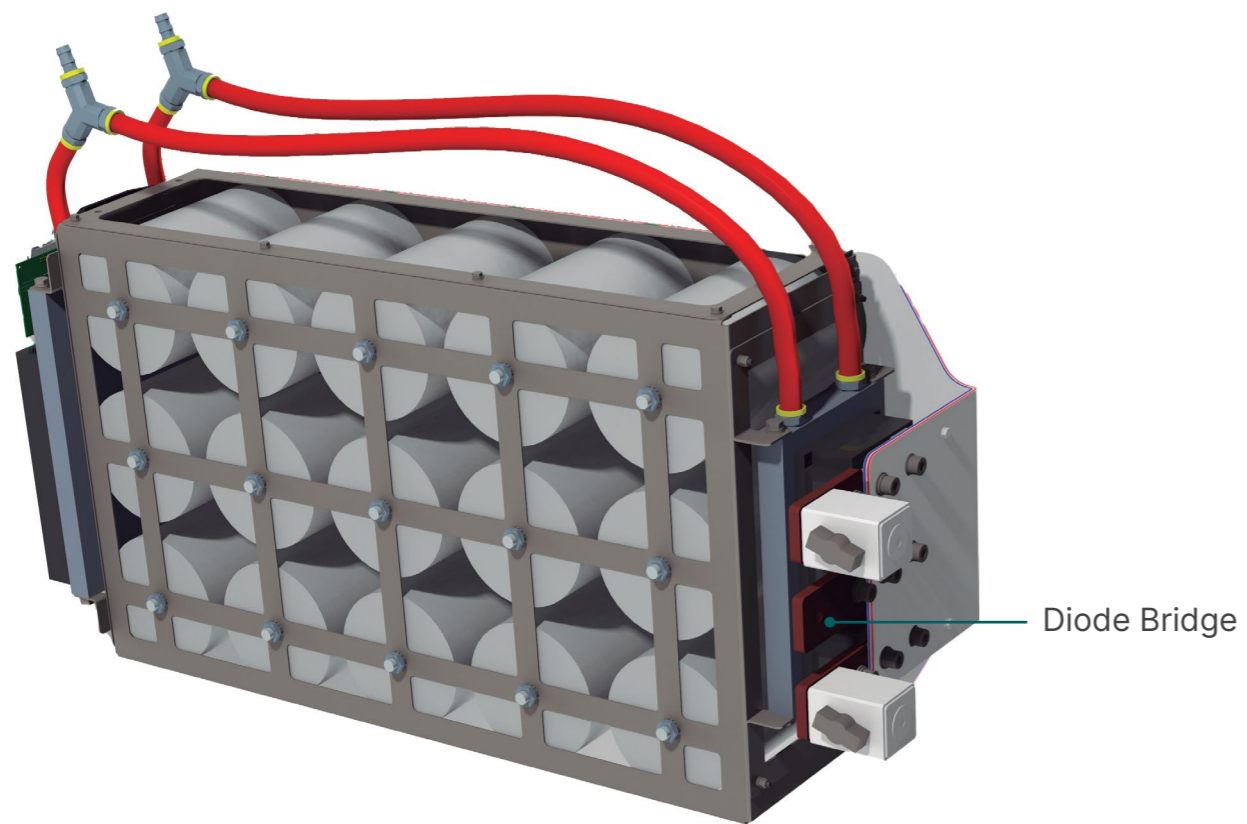
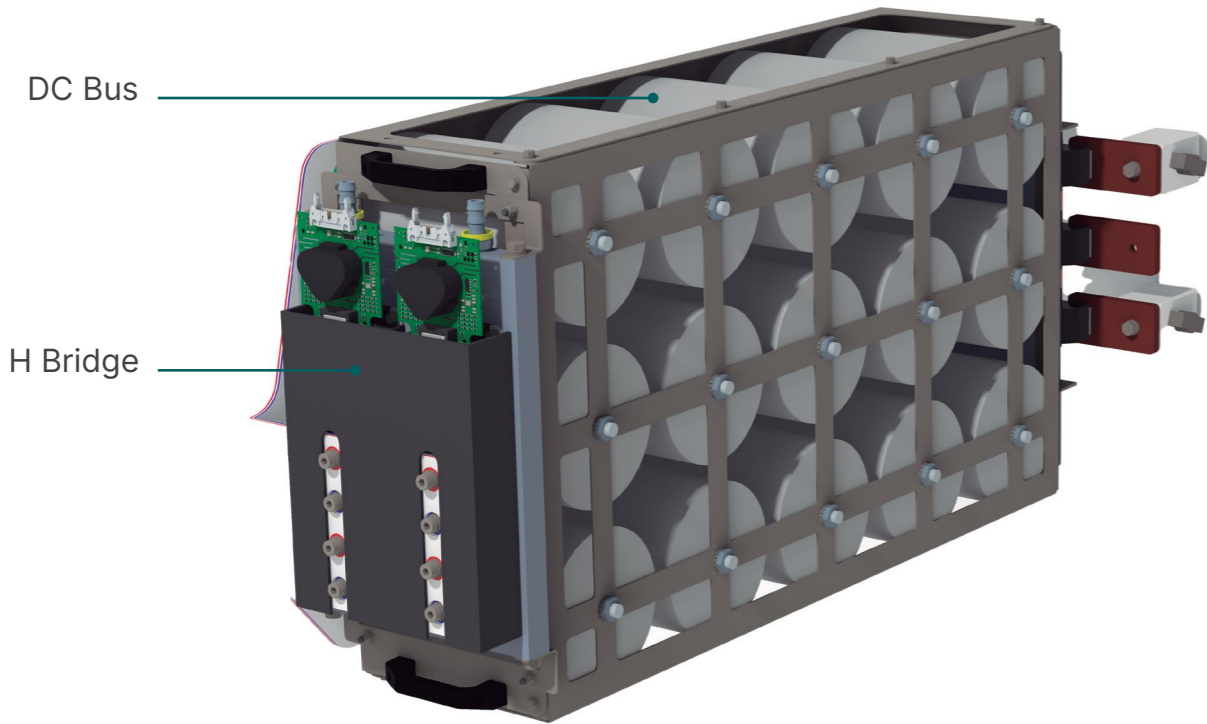

| Submodule Parameters | | Ratings |
|----------------------------|-------------|---------|
| Rated Power (MVA) | | 1 |
| VAC Output (Vrms) | | 850 |
| Maximum Output Current (A) | | 1320 |
| Dimensions | Width (mm) | 275 |
| | Depth (mm) | 995 |
| | Height (mm) | 550 |

TYPICAL CHARACTERISTICS

The design features high-efficiency IGBT power devices and employs fiber optic communication with the main controller for reliable system integration. It is also engineered to ensure the long-term durability of critical components.

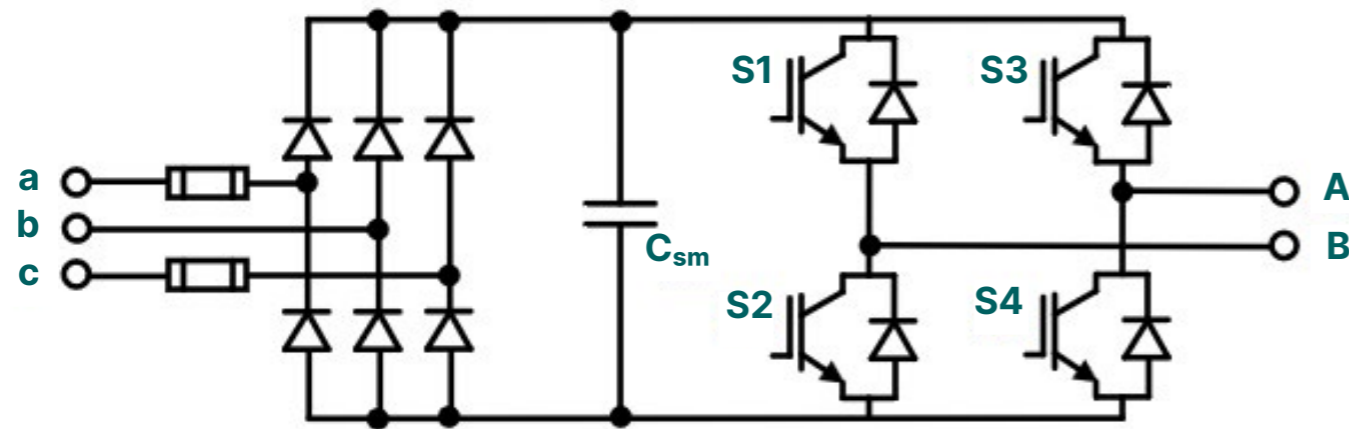

| General Characteristics | |
|--|---|
| Cooling Water | Raw water to deionized water heat exchanger Raw water inlet temp. 15°C to 38°C (>38°C or <0°C with derating) |
| Auxiliary Voltages | 120 VAC or 220 / 480 or 400 VAC |
| Front End Type | Diode Front End (DFE) |
| Efficiency | 97% |
| Supply Frequency | 50/60 Hz |
| Input Power Factor (PF) | >= 0.95 |
| Motor Type | Induction or Synchronous |
| Output Power Factor | 0 to 1 |
| dV/dt | < 3 kV/μs |
| Motor Inverter Type / Topology | Pulse Width Modulated (PWM), Cascaded Multi-Level H-Bridge |
| Rated Output Frequency | 0 to 300 Hz |
| Pressure Drop (at raw water connection point) | <1.5 bar at rated flow |
| Audio Noise | <85 dB (A), 1 m from cubicle line-up |
| Operating Ambient Temperature | 5°C to 45 °C |
| Storage Temperature | -20 °C to 55 °C (without water in cooling circuit, with glycol flushing) |
| Humidity | 5 to 95% (condensation not permitted) |
| Environmental class | Biological ambient conditions in accordance with class 3B1 according to IEC 60721-3-3 Chemical active substances in accordance with class 3C2 according to IEC 60721-3-3 |
| Insulation coordination | Pollution degree 2 (without conductive pollution) in acc. with IEC 61800-5-1:2022 |
| Altitude | < 1000m above mean sea level |
| Installation | Indoor |
| Paint | ANSI 61, RAL 7035 |
| Enclosure Protection Class | IP 31 (Air-cooled Transformer), IP54 (Water-cooled Transformer) |
| Regulation Compliances | U347A (2022), UL 61800-5-1 (2022), CSA 22.2 No. 274:17 (2017), UL 1561, UL 1562, IEC 61800-3, IEC 61800-4, IEC 61800-5 |
| Internal arc classification (according to IEC 62271-200: 2021) | IAC AFLR 35 kA @ 0.3s |
| Maintenance Access | 1. Front access for main components described in user manual(submodules, controller, cooling pumps, sensors) 2. Possible rear access provided for better maintenance |
| Power Cabling Connections | 1. Bottom entry: Input and output area are closed with removable metallic plate. – Provision for cable glands not included (Removable stainless steel shall be drilled per user requirement by the Customer). |



Contact US

Use phone or mail to log your case. Use contact details listed/complete form and return via email.



Communication

Our agents will confirm a unique case reference number and explain next steps to resolve the issue.



Case Details

Provide accurate the issue details and include company name, site, location, and best contact information.



Site Intervention

If our remote support and related instructions are not suitable enough, then our team will appoint time for our Field Service Engineers to come locally.

© 2025 GE Vernova and/or its affiliates. All rights reserved.

GE Vernova Proprietary Information - This document contains GE Vernova proprietary information. It is the property of GE Vernova and shall not be used, disclosed to others or reproduced without the express written consent of GE Vernova, including, but without limitation, in the creation, manufacture, development, or derivation of any repairs, modifications, spare parts, or configuration changes or to obtain government or regulatory approval to do so, if consent is given for reproduction in whole or in part, this notice and the notice set forth on each page of this document shall appear in any such reproduction in whole or in part. The information contained in this document may also be controlled by the US export control laws. Unauthorized export or re-export is prohibited. This presentation and the information herein are provided for information purposes only and are subject to change without notice. NO REPRESENTATION OR WARRANTY IS MADE OR IMPLIED AS TO ITS COMPLETENESS, ACCURACY, OR FITNESS FOR ANY PARTICULAR PURPOSE. All relative statements are with respect to GE technology unless otherwise noted. GE is a trademark of General Electric Company and is used under trademark license.

GEA35571_BCH_MV8 Product Overview_EN_06092025



GE VERNOVA