

# ELECTRIFYING CRITICAL PETROCHEMICAL COMPRESSORS

Multiple redundancy options for uninterrupted operation and unmatched reliability



As petrochemical companies accelerate decarbonization, many are evaluating the transition from steam turbine drivers to electric solutions for compression trains.

GE Vernova provides advanced Variable Speed Drive Systems (VSDS) designed to support these sustainability goals. Our VSDS technology offers robust control and energy-efficient operation for medium and high-power applications, including ethylene and propylene compression. When integrated into critical process environments, our solution is engineered to meet customer's specific requirements and supporting our customers' path toward reduced emissions and optimized operational performance.

## VARIABLE SPEED DRIVE SYSTEMS FOR MEDIUM AND HIGH-POWER COMPRESSORS

Our medium voltage VSDS for petrochemical compression trains features a Voltage Source Inverter (VSI) with a high-speed synchronous or induction machine, designed for ratings up to 100 MW.

By dynamically adjusting the speed of the compressors based on plant-provided operational specifications, the system helps lower energy consumption, improve operational flexibility, and support reduced carbon emissions compared to traditional steam turbine-driven systems.

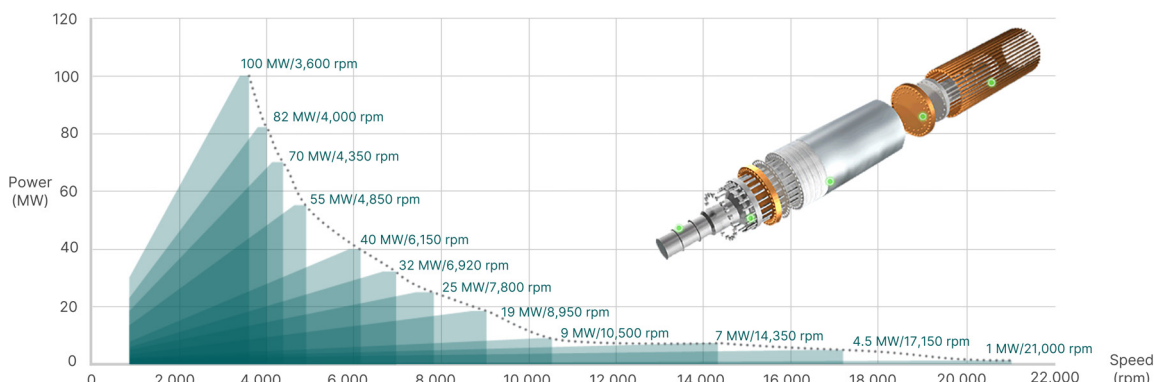

*High-speed induction machines' power and speed range*

# FEATURES & BENEFITS

Engineered for demanding petrochemical compressor applications, our VSDS offers architectural features to support customer's operational specific needs and robust control and performance across a wide operating envelope.

- **Redundancy architecture** - Features N+1 redundant VSI drive configurations to support operational availability
- **Switchover capability** - Designed with hot-catch redundancy; typical switchover times range from 50 ms to 250 ms, subject to site-specific load conditions
- **Advanced redundancy options** - Configurable options available for IGBT N+1, control redundancy, and auxiliary systems subject to customer's requirements
- **Engineered to facilitate component reparability** during system operation
- **Expected system efficiency ratings exceed 95%** at design specific conditions
- **Flexibility for a wide speed range** of 0 to 105%
- **Start times of less than one minute**
- Electrification solution supports customer decarbonization objectives
- Low operational maintenance requirements over the system life cycle
- Engineered to **support extended run times**, consistent with industry-standard maintenance cycles
- Motor directly coupled to the compressor, eliminating gearbox losses and simplifying the mechanical train

## SMOOTH AND FAST SWITCHOVER WITH VFD N+1 REDUNDANCY

In demanding petrochemical compressor applications, **VFD redundancy is designed to support specific high availability required by customers.** A common N+1 configuration includes one or more VFDs in operation with one additional VFD in hot standby, enabling automatic switchover in less than 250 ms in the event of a fault. Alternatively, two or more VFDs can operate in parallel and share the load equally or proportionally (for example, 50/50, 33/33/33, or 25/25/25/25), with fast, bumpless transfer and switchover times of less than 150 ms. These configurations **enhance operational robustness.**

The graph below shows representative site measurements of two VFDs sharing the load at 50% each, then switching to one VFD at 100% load and the other at 0%. Under these test conditions, motor and compressor speed remained stable, and the impact on air-gap torque controlled, supporting smooth, continuous operation.

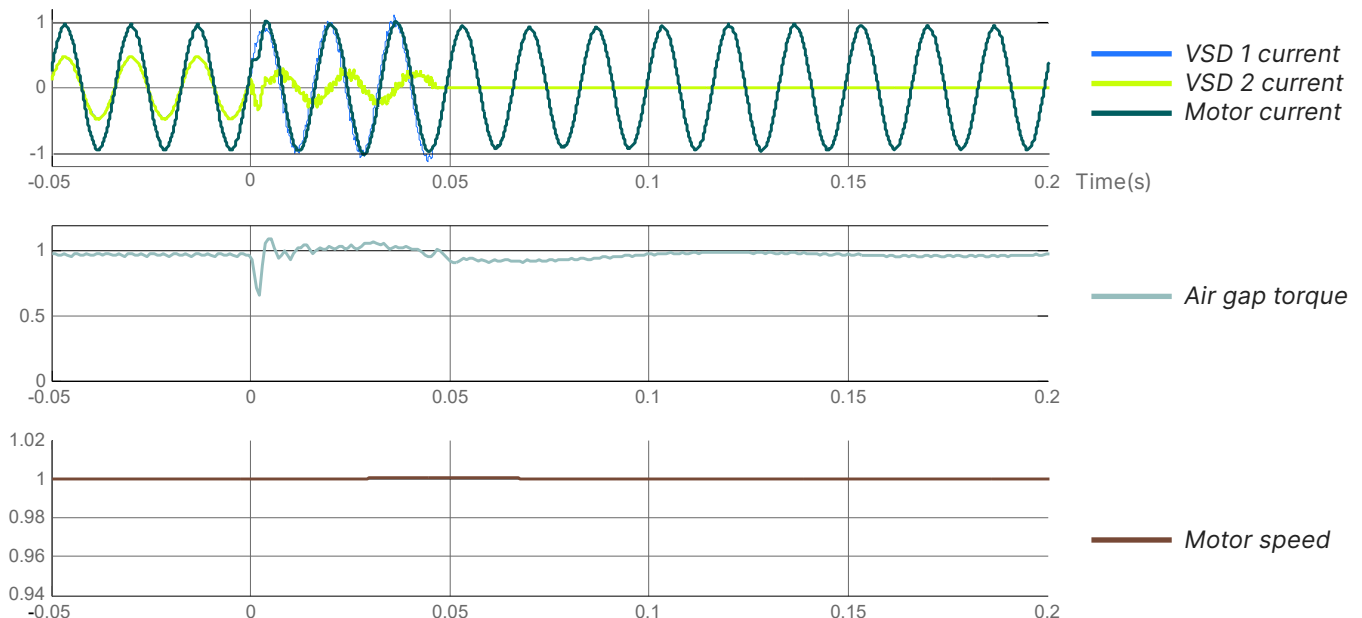

# VFD REDUNDANCY ARCHITECTURES

Various VFD redundancy architectures are available, selected based on customer's application requirements and power profile.

Figure 1 illustrates **three VFD redundancy architectures developed for specific compressor applications**. Application 1 uses a 3+1 configuration, Application 2 uses a 2+1 configuration, and Application 3 uses a 1+1 configuration. Each x+1 arrangement is selected to match the required power rating and load-sharing requirements of the application. In all cases, the N+1 design **supports operation in either load-sharing mode**, where all VFDs operate in parallel and share the load, **or standby mode**, where N unit(s) carry the full load and one unit serves as a spare, ready for fast takeover. **This approach provides both electrical sizing flexibility and high system availability.**

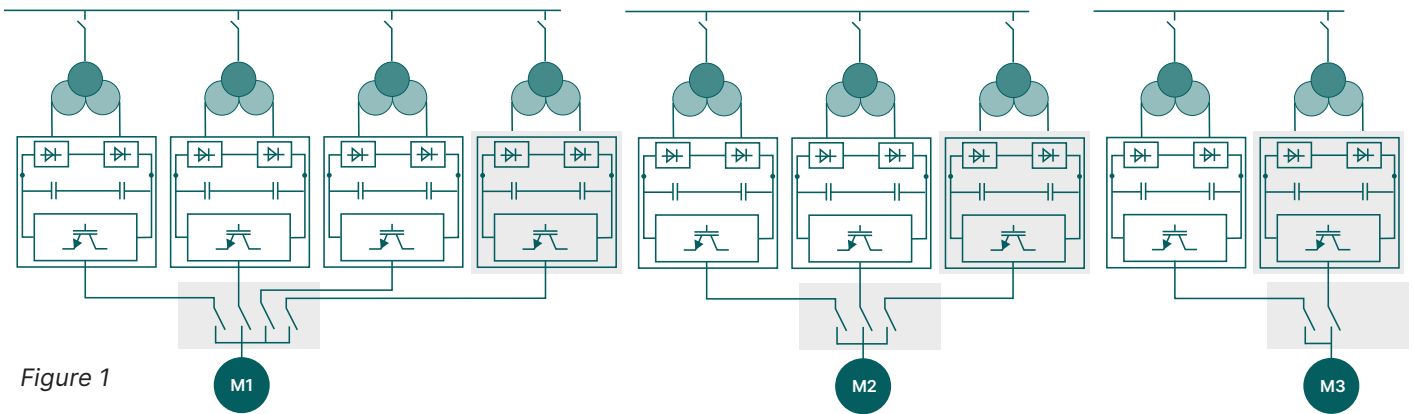

Figure 1

Another configuration is the N+1 architecture, in which **each motor is driven by its own dedicated VFD (N VFDs for N motors), with a single common standby unit** (Figure 2). In this setup, load sharing is not possible, and all VFDs are identical to ensure **full interchangeability**. In the event of a failure, **the standby VFD can automatically take over for any operating drive**, providing redundancy while maintaining **system simplicity and standardized operation**.

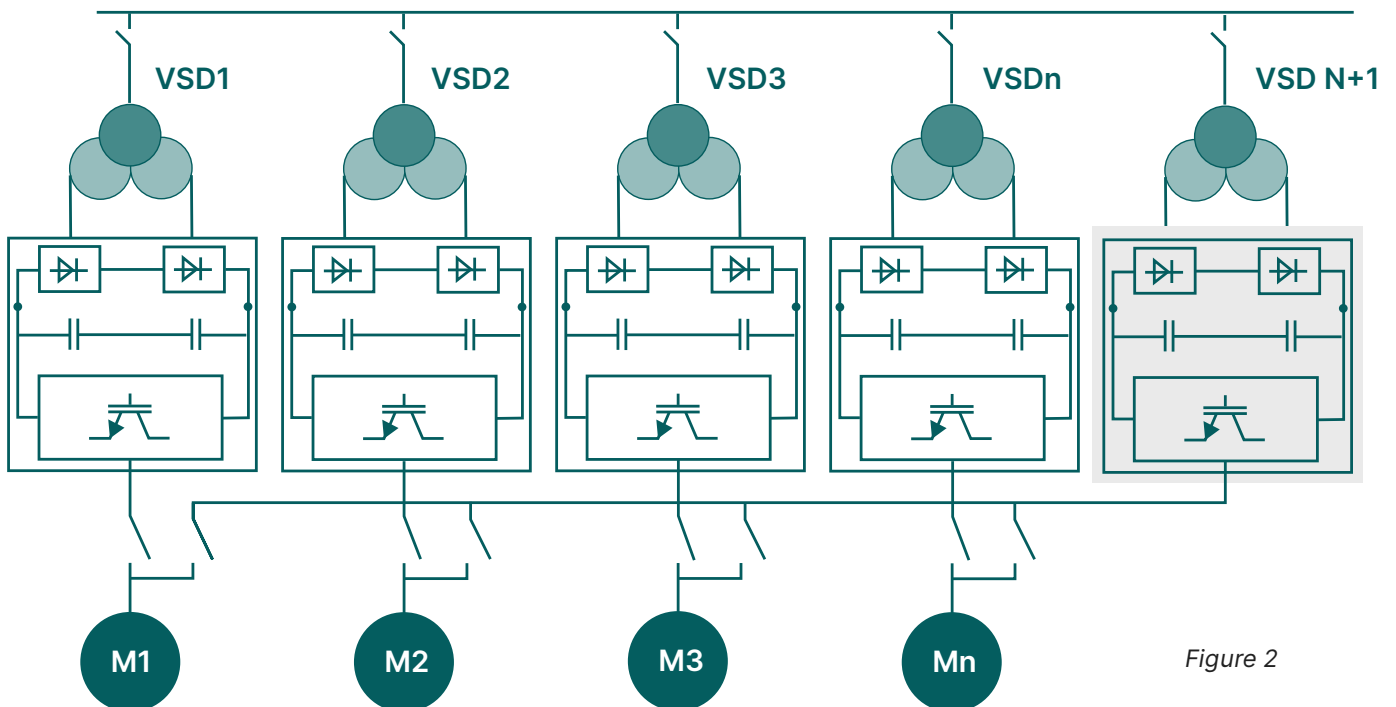

Figure 2

## About GE Vernova's Power Conversion & Storage business

GE Vernova's Power Conversion & Storage business combines advanced energy conversion and storage systems to meet the electrification needs of utilities and industries. With a focus on power stability, energy storage, and industrial electrification solutions, Power Conversion & Storage empowers customers by addressing their most complex electrification challenges and accelerating their transition to a sustainable, decarbonized future.

For more information, please visit  
[gevernova.com/power-conversion](https://gevernova.com/power-conversion)

© 2026 GE Vernova. All rights reserved.

GE and the GE Monogram are trademarks of General Electric Company used under trademark license.

GEA35610\_FS\_Electrifying-petrochemical-compressors\_EN\_20260527



**GE VERNOVA**